

**CANYON REGIONAL WATER AUTHORITY  
REGIONAL WATER SUPPLY STUDY  
FINAL REPORT**

Presented to:  
**Canyon Regional Water Authority**  
and  
**Texas Water Development Board**

June 15, 1990

**Michael Sullivan and Associates, Inc.  
Abbe/Garrett Engineering, Inc.  
Gebhard Engineers, Inc.**

**FINAL REPORT  
TABLE OF CONTENTS**

<b>SECTION</b>	<b>Page</b>
<b>1.0 INTRODUCTION</b>	
1.1 Authorization and Organization	1 - 1
1.2 Objectives and Scope	1 - 2
1.3 Contents of Report	1 - 3
<b>2.0 EXISTING CONDITIONS</b>	
2.1 Physical Features of Study Area	2 - 1
2.1.1 Geographical Location	2 - 1
2.1.2 Geology	2 - 1
2.1.3 Climate	2 - 3
2.1.4 Hydrology	2 - 3
2.1.5 Ecological Features	2 - 4
2.2 Populations, Water Demands and Sources	2 - 5
2.2.1 Current Conditions	2 - 5
2.2.2 Historical Uses	2 - 5
2.3 Existing Treatment Capacities and Infrastructure	2 - 10
2.3.1 General Description	2 - 10
2.3.2 Green Valley Water Supply Corporation	2 - 19
<u>General Description</u>	2 - 19
<u>Facilities Description</u>	2 - 19
<u>System Evaluation</u>	2 - 23
2.3.3 Springs Hill Water Supply Corporation	2 - 23
<u>General Description</u>	2 - 23
<u>Facilities Description</u>	2 - 23
<u>System Evaluation</u>	2 - 25
2.3.4 Crystal Clear Water Supply Corporation	2 - 25
<u>General Description</u>	2 - 25
<u>Facilities Description</u>	2 - 25
<u>System Evaluation</u>	2 - 29
2.3.5 East Central Water Supply Corporation	2 - 29
<u>General Description</u>	2 - 29
<u>Facilities Description</u>	2 - 29
<u>System Evaluation</u>	2 - 34
<b>3.0 POPULATION AND WATER DEMAND PROJECTIONS</b>	
3.1 Population Projections	3 - 1
3.1.1 Projection Methodology	3 - 1
<u>Low Series Population Estimates</u>	3 - 2
<u>High Series Population Estimates</u>	3 - 2
3.1.2 Population Projection Results	3 - 2

**FINAL REPORT  
TABLE OF CONTENTS  
(Continued)**

<b>SECTION</b>	<b>Page</b>
3.2 Water Demand Projections	3 - 2
3.2.1 Water Demand Projection Methodology	3 - 2
3.2.2 Water Demand Projection Results	3 - 8
3.3 Selection of Future Development Planning Scenarios	3 - 27
<b>4.0 WATER CONSERVATION</b>	
4.1 Introduction	4 - 1
4.1.1 Planning Area and Project	4 - 1
4.1.2 Utility Evaluation Data	4 - 1
4.1.3 Need for and Goals of Program	4 - 3
4.2 Long-Term Water Conservation	4 - 6
4.2.1 Plan Elements	4 - 6
<u>Education and Information</u>	4 - 7
<u>Plumbing Codes</u>	4 - 7
<u>Retrofit Program</u>	4 - 8
<u>Water Rate Structure</u>	4 - 9
<u>Universal Metering</u>	4 - 12
<u>Water Conservation Landscaping</u>	4 - 13
<u>Leak Detection and Repair</u>	4 - 13
<u>Recycle and Reuse</u>	4 - 14
4.2.2 Implementation and Enforcement	4 - 14
<u>Annual Reporting</u>	4 - 14
<u>Contracts With Other Political Subdivisions</u>	4 - 15
<b>5.0 FUTURE DEVELOPMENT PLANNING SCENARIOS</b>	
5.1 Supply Conditions	5 - 1
5.2 CRWA Future Development Assumptions	5 - 4
5.2.1 Green Valley Water Supply Corporation	5 - 4
5.2.2 Springs Hill Water Supply Corporation	5 - 5
5.2.3 Crystal Clear Water Supply Corporation	5 - 5
5.2.4 East Central Water Supply Corporation	5 - 5
5.3 Projected Demands	5 - 6
5.3.1 Green Valley Water Supply Corporation	5 - 6
5.3.2 Springs Hill Water Supply Corporation	5 - 9
5.3.3 Crystal Clear Water Supply Corporation	5 - 10
5.3.4 East Central Water Supply Corporation	5 - 13
5.3.5 Canyon Regional Water Authority	5 - 13
<b>6.0 PRELIMINARY WATER SUPPLY OPTION EVALUATION</b>	
6.1 Scope of Supply Option Search	6 - 1
6.2 Supply Option Selection Criteria	6 - 1

**FINAL REPORT  
TABLE OF CONTENTS  
(Continued)**

<b>SECTION</b>	<b>Page</b>
6.3 Supply Option Evaluation Criteria	6 - 1
6.3.1 Baseline Description	6 - 3
6.3.2 Short-Term Option Evaluation Criteria	6 - 4
6.3.3 Long-Term Option Evaluation Criteria	6 - 5
6.4 Supply Option Description	6 - 5
6.4.1 Limited/No Action Alternative	6 - 5
<u>Short-term Options (No Action)</u>	6 - 5
<u>Long-term Options (Limited Action)</u>	6 - 6
6.4.2 Purchase Supplies from Others	6 - 6
<u>Guadalupe Blanco River Authority</u>	6 - 6
<u>New Braunfels/San Marcos</u>	6 - 9
<u>Edwards Underground Water District</u>	6 - 11
<u>Irrigation Rights</u>	6 - 11
6.4.3 Wells	6 - 12
<u>Shallow Wells</u>	6 - 12
<u>Leona Formation</u>	6 - 12
<u>Carrizo-Wilcox</u>	6 - 12
6.4.4 Conjunctive Use/Subordination of GBRA Hydropower Rights	6 - 14
6.4.5 Surface Water Appropriation Without Impoundment	6 - 32
<u>Guadalupe River Within Service Area</u>	6 - 32
<u>Guadalupe River Other</u>	6 - 32
<u>San Marcos River</u>	6 - 32
6.4.6 Surface Water Appropriation With Impoundment	6 - 35
<u>Guadalupe River Within Service Area</u>	6 - 35
<u>Guadalupe River Other</u>	6 - 35
<u>San Marcos River</u>	6 - 36
6.4.7 Transfer of Coastal Basin Demands	6 - 36
<u>Improve Coastal Canal Systems</u>	6 - 37
6.4.8 Recharge of Local Ground Water Formations	6 - 38
6.4.9 Wastewater Reuse	6 - 38
6.5 Supply Option Matrix Evaluation	6 - 38
6.5.1 Limited/No Action Alternative	6 - 38
<u>No Action Alternative</u>	6 - 38
<u>Limited Action Alternative</u>	6 - 39
6.5.2 Purchase Water From Others	6 - 49
<u>Guadalupe-Blanco River Authority</u>	6 - 49
<u>New Braunfels/San Marcos</u>	6 - 49
<u>Edwards Underground Water District</u>	6 - 50



**FINAL REPORT  
TABLE OF CONTENTS  
(Continued)**

<b>SECTION</b>	<b>Page</b>
<u>Irrigation Water Rights</u>	6 - 50
6.5.3 Wells	6 - 50
<u>Local Shallow Wells</u>	6 - 50
<u>Leona Formation</u>	6 - 51
<u>Carrizo-Wilcox Formation</u>	6 - 51
6.5.4 Conjunctive Use or Subordination of GBRA Hydropower Rights	6 - 51
6.5.5 Appropriation of Surface Water Without Impoundment	6 - 52
<u>Guadalupe River Within Service Area</u>	6 - 52
<u>Guadalupe River Other</u>	6 - 52
<u>San Marcos River</u>	6 - 52
6.5.6 Appropriation Surface Water With Impoundment	6 - 52
<u>Guadalupe River Within Service Area</u>	6 - 52
<u>Guadalupe River Other</u>	6 - 52
<u>San Marcos</u>	6 - 53
6.5.7 Transfer of Coastal Basin Demands	6 - 53
6.5.8 Improve Coastal Canal System	6 - 53
6.6 Supply Options Recommended for Detailed Evaluation	6 - 54
<b>7.0 DETAILED COST EVALUATION</b>	
7.1 General	7 - 1
7.1.1 Short-term Options	7 - 1
7.1.2 Long-term Options	7 - 1
7.2 Phased Improvements	7 - 2
7.3 Construction Costs	7 - 8
7.4 Supply/Treatment	7 - 9
7.5 Storage	7 - 10
7.6 Pumping	7 - 10
7.7 Transmission Mains	7 - 10
7.8 Cost Evaluation Summary	7 - 15
7.8.1 Option 1 - Purchase Water from GBRA w/ Treatment by CRWA	7 - 15
7.8.2 Option 2 - Purchase Treated Water from GBRA	7 - 26
7.8.3 Option 3 - Purchase Water from GBRA w/ Treatment by the City of Seguin	7 - 26
7.8.4 Option 4 - Develop Well fields into the Carrizo-Wilcox Formation	7 - 41
7.8.5 Option 5 Appropriate Surface Water Downstream of GBRA Hydropower Dam H-5	7 - 41
7.9 Summary Option Cost Comparison	7 - 57
7.10 Costs of Option 1 for each CRWA Member WSC	7 - 57
<b>8.0 INSTITUTIONAL AND LEGAL ISSUES</b>	
8.1 Rights of Way Acquisition	8 - 1
8.2 Water Rights	8 - 2
8.3 Intergovernmental Contracting Methods	8 - 3

**FINAL REPORT  
TABLE OF CONTENTS  
(Continued)**

<b>SECTION</b>	<b>Page</b>
8.4 Regional Water Supply Implications	8 - 3
<b>9.0 CONCLUSIONS AND RECOMMENDATIONS</b>	
9.1 Conclusions	9 - 1
9.1.1 Future Demands	9 - 1
9.1.2 Future Supplies	9 - 1
Quantities	9 - 1
Sources	9 - 4
9.2 Recommendations	9 - 8

## LIST OF FIGURES

Fig.	Title	Page
ES-1	Guadalupe River Basin Watersheds 9 & 11	ES - 4
ES-2	Projected CRWA Member Future Populations High Series	ES - 5
ES-3	Projected CRWA Member Future Water Demand High Population Series High Per Capita Use With Conservation	ES - 6
ES-4	Drought Case Projected CRWA Member Future Water Demand and Supplies	ES - 8
ES-5	Drought Case Projected CRWA Member Future Water Demand and Required Supplemental Supplies	ES - 9
ES-6	Projected CRWA Member Future Required Supplemental Supplies	ES - 10
ES-7	Cost/1,000 gal of Major CRWA Supply Options	ES - 11
ES-8	Cost/1,000 gal for Each WSC - CRWA Treatment Option	ES - 14
ES-9	CRWA and GBRA Treatment and Distribution Options	ES - 16
2-1	CRWA Study Area Location Map	2 - 2
2-2	GWSC Historical Use and Source	2 - 9
2-3	SHWSC Historical Use and Source	2 - 12
2-4	CCWSC Historical Use and Source	2 - 15
2-5	ECWSC Historical Use and Source	2 - 17
2-6	Generalized CRWA Infrastructure	2 - 18
2-7	GWSC Service Area	2 - 20
2-8	SHWSC Service Area	2 - 24
2-9	CCWSC Service Area	2 - 28
2-10	ECWSC Service Area	2 - 32
3-1	Projected CRWA Member Future Populations/Low Series	3 - 4
3-2	Projected CRWA Member Future Populations/Low Series	3 - 5
3-3	Projected CRWA Member Future Populations/ High Series	3 - 6
3-4	Projected CRWA Member Future Populations/ High Series	3 - 7
3-5	GWSC Future Demands /Low Population Series	3 - 10
3-6	GWSC Future Demands /High Population Series	3 - 11
3-7	SHWSC Future Demands/ High Population Series	3 - 12
3-8	SHWSC Future Demands/ Low Population Series	3 - 13
3-9	CCWSC Future Demands/ Low Population Series	3 - 14

## LIST OF FIGURES

Fig.	Title	Page
3-10	CCWSC Future Demands/ High Population Series	3 - 15
3-11	ECWSC Future Demands/ Low Population Series	3 - 16
3-12	ECWSC Future Demands / High Population Series	3 - 17
3-13	Projected CRWA Member Future Water Demand Low Population Series Average Per Capita Use Without Conservation	3 - 18
3-14	Projected CRWA Member Future Water Demand Low Population Series Average Per Capita Use With Conservation	3 - 19
3-15	Projected CRWA Member Future Water Demand Low Population Series High Per Capita Use Without Conservation	3 - 20
3-16	Projected CRWA Member Future Water Demand Low Population Series High Per Capita Use With Conservation	3 - 21
3-17	Projected CRWA Member Future Water Demand High Population Series Average Per Capita Use Without Conservation	3 - 22
3-18	Projected CRWA Member Future Water Demand High Population Series Average Per Capita Use With Conservation	3 - 23
3-19	Projected CRWA Member Future Water Demand High Population Series High Per Capita Use Without Conservation	3 - 24
3-20	Projected CRWA Member Future Water Demand High Population Series High Per Capita Use With Conservation	3 - 25
3-21	Total Projected CRWA Demand (Per Capita Use/Population Series/Conservation)	3 - 26
4-1	Projected CRWA Total Water Demands With and Without Conservation High Per Capita Use/High Population Series	4 - 5
5-1	Best Case Projected CRWA Member Future Water Demand and Supplies	5 - 15
5-2	Best Case Projected CRWA Member Future Water Demand and Required Supplemental Supplies	5 - 16
5-3	Probable Case Projected CRWA Member Future Water Demand and Supplies	5 - 17
5-4	Probable Case Projected CRWA Member Future Water Demand and Required Supplemental Supplies	5 - 18
5-5	Worst Case Projected CRWA Member Future Water Demand and Supplies	5 - 19
5-6	Worst Case Projected CRWA Member Future Water Demand and Required Supplemental Supplies	5 - 20
5-7	Drought Case Projected CRWA Member Future Water Demand and Supplies	5 - 21
5-8	Drought Case Projected CRWA Member Future Water Demand and Required Supplemental Supplies	5 - 22

## LIST OF FIGURES

Fig.	Title	Page
5-9	Projected CRWA Member Future Required Supplemental Supplies	5 - 23
6-1	CRWA Study Location Map	6 - 2
6-2	City of Seguin Projections of Municipal Water Demands and Available Capacity High Per Capita Water Use Scenario	6 - 8
6-3	City of New Braunfels Projections of Municipal Water Demands High Per Capita Water Use Series	6 - 10
6-4	The Carrizo/Wilcox Aquifer in South Texas	6 - 13
6-5	Location Map GBRA Hydropower Dam TP-1 (Lake Dunlap)	6 - 16
6-6	Location Map Lake McQueeney	6 - 18
6-7	Location Map GBRA Hydropower Dams H-4 and H-5	6 - 20
6-8	Watersheds of the Guadalupe River Basin	6 - 21
6-9	Guadalupe River Basin Watershed 7 and 8	6 - 22
6-10	Guadalupe River Basin Watershed 9 and 11	6 - 23
6-11	Daily Flow Frequency Distribution Comal River at New Braunfels	6 - 25
6-12	Annual Flow Frequency Distribution Comal River at New Braunfels	6 - 26
6-13	Daily Flow Frequency Distribution Guadalupe River Above Comal River at New Braunfels	6 - 27
6-14	Annual Flow Frequency Distribution Guadalupe River Above Comal River at New Braunfels	6 - 28
6-15	Daily Flow Frequency Distribution Combined Guadalupe and Comal Rivers Below New Braunfels	6 - 29
6-16	Annual Flow Frequency Distribution Combined Guadalupe and Comal Rivers Below New Braunfels	6 - 30
6-17	Best Case Projected CRWA Member Future Water Demand and Supplies - No Action Alternative	6 - 40
6-18	Best Case Projected CRWA Member Future Water Demand and Required Supplemental Supplies	6 - 41
6-19	Probable Case Projected CRWA Member Future Water Demand and Supplies - No Action Alternative	6 - 42
6-20	Probable Case Projected CRWA Member Future Water Demand and Required Supplemental Supplies	6 - 43
6-21	Worst Case Projected CRWA Member Future Water Demand and Supplies No Action Alternative	6 - 44
6-22	Worst Case Projected CRWA Member Future Water Demand and Required Supplemental Supplies	6 - 45

## LIST OF FIGURES

Fig.	Title	Page
6-23	Drought Case Projected CRWA Member Future Water Demand and Supplies	6 - 46
6-24	Drought Case Projected CRWA Member Future Water Demand and Required Supplemental Supplies	6 - 47
6-25	Projected CRWA Member Future Required Supplemental Supplies	6 - 48
7-1	Drought Case Projected CRWA Member Future Water Demand and Supplies	7 - 5
7-2	Drought Case Projected CRWA Member Future Water Demand and Required Supplemental Supplies	7 - 6
7-3	Projected CRWA Member Future Required Supplemental Supplies	7 - 7
7-4	CRWA or GBRA Treatment and Distribution Options	7 - 16
7-5	Cost/1,000 gal of Water Purchased from GBRA and treated in a CRWA Facility Assuming 2,250, 4,500 and 900 AF/yr Purchase Increments	7 - 23
7-6	Total Annual Cost of Water Purchased from GBRA and treated in a CRWA Facility Assuming 2,250, 4,500 and 9,00 AF/yr Purchase Increments	7 - 24
7-7	Cumulative Cost of Water Purchased from GBRA and treated in a CRWA Facility Assuming 2,250, 4,500 and 9,000 AF/yr Purchase Increments	7 - 25
7-8	Cost/1,000 gal of Water Purchased from GBRA	7 - 31
7-9	Annual Cost Water Purchased from GBRA	7 - 32
7-10	Cumulative Cost of Water Purchased	7 - 33
7-11	Development Option Utilizing Excess Capacity of Existing Seguin WTP through 2005 in Conjunction with New CRWA or GBRA Constructed Facilities	7 - 34
7-12	Cost/1,000 gal of use of Seguin WTP Excess Capacity in Combination with Construction of CRWA Treatment Facilities Assuming 2,250 4,500 and 9,000 AF/yr Purchase Increments	7 - 42
7-13	Total Annual Cost of Use of Seguin WTP Excess Capacity in Combination with Construction of CRWA Treatment Facilities Assuming 2,250, 4,500 and 9,000 AF/yr Purchase Increments	7 - 43
7-14	Cumulative Cost of Use of Seguin WTP Excess Capacity in Combination with Construction of CRWA Treatment Facilities Assuming 2,250, 4,500 and 9,000 AF/yr Purchase Increments	7 - 44
7-15	Carrizo-Wilcox Well Option	7 - 45
7-16	Cost/1,000 gal of Carrizo-Wilcox Water	7 - 51
7-17	Total Annual Cost of Carrizo-Wilcox Water	7 - 52
7-18	Cumulative Cost of Carrizo-Wilcox Water	7 - 53
7-19	CRWA Use of GBRA Hydropower Dam H-5 as a Possible Future Water Source	7 - 54

## LIST OF FIGURES

Fig.	Title	Page
7-20	Cost/1,000 gal of Appropriation Below GBRA Hydropower Dam H-5	7 - 60
7-21	Total Annual Cost of Appropriation Below GBRA Hydropower Dam H-5	7 - 61
7-22	Cumulative Cost of Appropriation Below GBRA Hydropower Dam H-5	7 - 62
7-23	Cost/1,000 gal of Major CRWA Supply Options	7 - 63
7-24	Total Annual Cost of Major CRWA Supply Options	7 - 64
7-25	Cumulative Cost of Major CRWA Supply Options	7 - 65
7-26	Cost/1,000 gal of Option 1 for Each WSC	7 - 68
7-27	Total Annual Cost of Option 1 for Each WSC	7 - 69
7-28	Cumulative Cost of Option 1 for Each WSC	7 - 70
9-1	Projected CRWA Member Future Populations High Series	9 - 2
9-2	Projected CRWA Member Future Water Demand High Population Series High Per Capita Use With Conservation	9 - 3
9-3	Drought Case Projected CRWA Member Future Water Demand and Supplies	9 - 5
9-4	Drought Case Projected CRWA Member Future Water Demand and Required Supplemental Supplies	9 - 6
9-5	Projected CRWA Member Future Required Supplemental Supplies	9 - 7
9-6	Cost/1,000 gal of Major CRWA Supply Options	9 - 9
9-7	CRWA and GBRA Treatment and Distribution Options	9 - 11

## LIST OF TABLES

<b>Table</b>	<b>Title</b>	<b>Page</b>
2-1	CRWA Member WSC Populations & Water Uses	2 - 6
2-2	GVWSC Historical Use	2 - 7
2-3	SHWSC Historical Use	2 - 11
2-4	CCWSC Historical Use	2 - 13
2-5	ECWSC Historical Use	2 - 16
2-6	GVWSC System Component Summary	2 - 21
2-7	SHWSC System Component Summary	2 - 26
2-8	CCWSC System Component System	2 - 30
2-9	ECWSC System Component System	2 - 33
3-1	Estimated Population of CRWA Members WSC Service Area	3 - 3
3-2	Estimated Total CRWA Water Demand	3 - 9
4-1	Expected Savings to the CRWA Member WSCs Through Implementation of a Water Use Retrofit Program	4 - 8
5-1	Drought Management Plan Trigger Conditions and Response Goals	5 - 3
5-2	Projected Supply Demand Summary CRWA	5 - 7
5-3	Best Case Supply Option Projection GVWSC	5 - 8
5-4	Probable Case Supply Option Projection GVWSC	5 - 8
5-5	Worst Case Supply Option Projection GVWSC	5 - 8
5-6	Drought Condition Supply Option Projection GVWSC	5 - 8
5-7	Best Case Supply Option Projection SHWSC	5 - 11
5-8	Probable Case Supply Option Projection SHWSC	5 - 11
5-9	Worst Case Supply Option Projection SHWSC	5 - 11
5-10	Drought Condition Supply Option Projection SHWSC	5 - 11
5-11	Best Case Supply Option Projection CCWSC	5 - 12
5-12	Probable Case Supply Option Projection CCWSC	5 - 12
5-13	Worst Case Supply Option Projection CCWSC	5 - 12
5-14	Drought Condition Supply Option Projection CCWSC	5 - 12
5-15	Best Case Supply Option Projection ECWSC	5 - 13
5-16	Probable Case Supply Option Projection ECWSC	5 - 13



## LIST OF TABLES

<b>Table</b>	<b>Title</b>	<b>Page</b>
5-17	Worst Case Supply Option Projection ECWSC	5 - 13
5-18	Drought Condition Supply Option Projection ECWSC	5 - 13
5-19	Best Case Supply Option Projection CRWA	5 - 14
5-20	Probable Case Supply Option Projection CRWA	5 - 14
5-21	Worst Case Supply Option Projection CRWA	5 - 14
5-22	Drought Condition Supply Option Projection CRWA	5 - 14
6-1	TP-1 Dam and Lake Dunlap	6 - 15
6-2	Abbott Dam (TP-3) and Lake McQueeney	6 - 17
6-3	H-4 Dam and H-4 Reservoir	6 - 19
6-4	Guadalupe River Basin Estimated Quantities of Unappropriated Surface Water in AF in Watershed 8	6 - 24
6-5	Guadalupe River Basin Estimated Quantities of Unappropriated Surface Water in AF in Watershed 9	6 - 33
6-6	Guadalupe River Basin Estimated Quantities of Unappropriated Surface Water in AF in Watershed 11	6 - 34
6-7	Supply Option Advantages and Disadvantages	6 - 55
6-8	CRWA Water Supply Options Evaluation Matrix	6 - 62
6-9	Supply Options	6 - 54
7-1	Probable Case Drought Condition Supply Option Projection GWWSC	7 - 3
7-2	Probable Case Drought Condition Supply Option Projection SHWSC	7 - 3
7-3	Probable Case Drought Condition Supply Option Projection CCWSC	7 - 3
7-4	Probable Case Drought Condition Supply Option Projection ECWSC	7 - 3
7-5	Probable Case Drought Condition Supply Option Projection CRWA	7 - 4
7-6	Summary of Total and Elevated Storage Requirements GWWSC	7 - 11
7-7	Summary of Total and Elevated Storage Requirements SHWSC	7 - 11
7-8	Summary of Total and Elevated Storage Requirements CCWSC	7 - 11
7-9	Summary of Total and Elevated Storage Requirements ECWSC	7 - 11
7-10	Summary of Total and Elevated Storage Requirements CRWA	7 - 12
7-11	Elevated Storage Cost and Scheduling CRWA	7 - 12
7-12	Pumping Requirements/Deficit/Surplus GWWSC	7 - 13

## LIST OF TABLES

<b>Table</b>	<b>Title</b>	<b>Page</b>
7-13	Pumping Requirements/Deficit/Surplus SHWSC	7 - 13
7-14	Pumping Requirements/Deficit/Surplus CCWSC	7 - 13
7-15	Pumping Requirements/Deficit/Surplus ECWSC	7 - 13
7-16	Pumping Requirements/Deficit/Surplus CRWA	7 - 14
7-17	Cumulative Pumping Requirements and Estimated Costs CRWA	7 - 14
7-18	Phase I Installation of Major Transmission Mains Purchase Water from GBRA with CRWA Treatment	7 - 17
7-19	Phase II Installation of Major Transmission Mains Purchase Water from GBRA with CRWA Treatment	7 - 18
7-20	Estimated Treatment Plant Costs - Purchase Water from GBRA with CRWA Treatment	7 - 19
7-21	Estimated Transmission Line Costs - Purchase Water from GBRA with CRWA Treatment	7 - 19
7-22	Cost Analysis of CRWA Purchase, Treatment and Distribution Option (2,250 AF/yr Purchase Increment)	7 - 20
7-23	Cost Analysis of CRWA Purchase, Treatment and Distribution Option (4,500 AF/yr Purchase Increment)	7 - 21
7-24	Cost Analysis of CRWA Purchase, Treatment and Distribution Option (9,000 AF/yr Purchase Increment)	7 - 22
7-25	Phase I Installation of Major Transmission Mains Purchase Treated Water from GBRA	7 - 27
7-26	Phase II Installation of Major Transmission Mains Purchase Treated Water from GBRA	7 - 28
7-27	Estimated Treatment Plant Costs - Purchase Water from GBRA with GBRA Treatment	7 - 29
7-28	Estimated Transmission Line Costs - Purchase Water from GBRA with GBRA Treatment	7 - 29
7-29	Cost Analysis of GBRA Treatment with CRWA Distribution Option (No Take-Or-Pay Restrictions)	7 - 30
7-30	Phase I Installation of Major Transmission Mains - Seguin/CRWA Treatment	7 - 35
7-31	Phase II Installation of Major Transmission Mains - Seguin/CRWA Treatment	7 - 36
7-32	Estimated Treatment Plant Costs - Purchase Water from GBRA with Seguin/CRWA Treatment	7 - 37
7-33	Estimated Transmission Line Costs - Purchase Water from GBRA with Seguin/CRWA Treatment	7 - 37
7-34	Cost Analysis of Use of Seguin WTP Excess Capacity in Combination with CRWA Treatment and Distribution Facilities (2,250 AF/yr Purchase Increment)	7 - 38
7-35	Cost Analysis of Use of Seguin WTP Excess Capacity in Combination with CRWA Treatment and Distribution Facilities (4,500 AF/yr Purchase Increment)	7 - 39

## LIST OF TABLES

<b>Table</b>	<b>Title</b>	<b>Page</b>
7-36	Cost Analysis of Use of Seguin WTP Excess Capacity in Combination with CRWA Treatment and Distribution Facilities (9,000 AF/yr Purchase Increment)	7 - 40
7-37	Phase I Installation of Major Transmission Mains Development of Well Field in Carrizo-Wilcox (1990-2005)	7 - 46
7-38	Phase II Installation of Major Transmission Mains Development of Well Field in Carrizo-Wilcox (2005-2020)	7 - 47
7-39	Estimated Treatment Plant Costs - Well Development in the Carrizo-Wilcox Aquifer	7 - 48
7-40	Estimated Transmission Line Costs - Well Development in the Carrizo-Wilcox Aquifer	7 - 48
7-41	Cost Analysis of Carrizo-Wilcox Supply Option	7 - 49
7-42	Phase I Installation of Major Transmission Mains CRWA Construction Surface Water Treatment Plant at GBRA Hydrodam H-5	7 - 55
7-43	Phase II Installation of Major Transmission Mains CRWA Construction Surface Water Treatment Plant at GBRA Hydrodam H-5	7 - 56
7-44	Estimated Treatment Costs - Appropriation Without Impoundment Below GBRA Hydropower Dam H-5	7 - 58
7-45	Estimated Transmission Line Costs - Appropriation Without Impoundment Below GBRA Hydropower Dam H-5	7 - 58
7-46	Cost Analysis of Conjunctive Use of GBRA Hydropower Dam H-5 Supply Option	7 - 59
7-47	Phase I Installation of Major Transmission Lines (1990-2005) - Purchase Water from GBRA with CRWA Transmission Supply Option	7 - 66
7-48	Phase II Installation of Major Transmission Lines (2005-2020) - Purchase Water from GBRA with CRWA Transmission Supply Option	7 - 67

## EXECUTIVE SUMMARY

In recent years the City of San Antonio and surrounding areas have experienced rapid growth and industrial development. As a result, the Edwards Aquifer which serves as the principal water supply source for the region has been subjected to increasing levels of stress both from higher withdrawals and diminution of water quality resulting from polluted point or nonpoint source recharge. The Texas Water Development Board (TWDB) and Edwards Underground Water District (EUWD) have each implemented programs to protect the Edwards Aquifer as a future dependable and high quality supply source for all users in the area. To that end the TWDB and EUWD are currently encouraging transport pumpers, i.e., those users whose service areas are not located directly over the Edwards Aquifer, to begin investigating alternative sources to satisfy future demands. In addition, the EUWD has enacted a drought management plan that will severely restrict availability of Edwards Aquifer water to all users in the event of a severe or prolonged drought. Thus it is imperative that all Edwards Aquifer water users begin to examine potential supplementary or alternative water sources.

The TWDB, through its continuing Regional Water and Wastewater Planning Grant Program, has identified the area to the northeast and east of San Antonio as typical of Edwards Aquifer user systems that should begin securing alternative future water sources. This study, financed in part by the TWDB, was initiated as a result of House Bill 2 and House Joint Resolution 6, passed by the 65th Texas Legislature in 1985, in order to encourage cost-effective regional water and wastewater facility development.

The Canyon Regional Water Authority (CRWA) was created in response to the expressed intentions of the TWDB and EUWD to limit pumpage from the Edwards Aquifer for all users and to encourage development of alternative future sources for those users not located directly over the aquifer. The CRWA is comprised of four water supply corporations (WSCs); Green Valley, Crystal Clear, Springs Hill and East Central. All four WSCs derive all or part of their water supplies either directly or indirectly from the Edwards Aquifer. The combined service area of the CRWA member WSCs measures approximately 618 square miles and covers nearly all of Guadalupe County, a large portion of Bexar County, and smaller portions of Hays, Wilson and Comal Counties.

The CRWA applied for and was awarded a 50% matching fund TWDB Planning Grant to develop a regional plan to supply the future water needs of the service area. Of primary interest was the investigation of supplies alternative to the Edwards Aquifer. Accordingly, the CRWA contracted with the consortium Michael Sullivan and Associates, Inc., Gebhard Engineering, Inc. and Abbe/Garrett Engineering, Inc. to perform this regional water supply study.

The study area for this study was limited to the service area of the four CRWA member WSCs. Under the terms of the TWDB Planning Grant, the CRWA could plan for additional surrounding areas and cities within

CANYON REGIONAL WATER SUPPLY STUDY  
EXECUTIVE SUMMARY

the service area; however, efforts to enlist the interest and support of additional future members or potential wholesale water customers was fruitless. Therefore, all demand and supply projections of this study are confined to the needs of the current CRWA service area.

The objective of this study was to project, through the year 2020, populations and supply demands of the four WSCs and then to identify feasible future supply and treatment development alternatives sufficient to supply those demands. Special emphasis was placed on alternatives that would minimize dependence on the Edwards Aquifer as a primary supply source. Infrastructure development was limited to major transmission and distribution systems and WSC interconnects that would ensure an equitable supply to all users under drought conditions.

A variety of future water supply and development options for the CRWA, and its member WSCs, were developed and evaluated. Initially, twenty-three feasible supply options were identified and subjected to a preliminary screening analysis. Those options included:

- **Limited/No Action Alternative**
- **Purchase Supplies from Others**
  - Guadalupe Blanco River Authority
  - New Braunfels/San Marcos
  - Edwards Underground Water District
  - Irrigation Rights
- **Wells**
  - Shallow Wells
  - Leona Formation
  - Carrizo-Wilcox
- **Conjunctive Use/Subordination of GBRA Hydropower Rights**
- **Surface Water Appropriation Without Impoundment**
  - Guadalupe River Within Service Area
  - Guadalupe River Other
  - San Marcos River
- **Surface Water Appropriation With Impoundment**
  - Guadalupe River Within Service Area
  - Guadalupe River Other
  - San Marcos River
- **Transfer of Coastal Basin Demands**
- **Recharge of Local Ground Water Formations**
- **Wastewater Reuse**

In addition to the No Action/Limited Action Alternative, five options were selected for rigorous estimation of implementation feasibility and cost. Those options are (Figure ES-1):

- **Purchase water from GBRA with treatment by CRWA** - Purchase water from GBRA through a take-or-pay contract and construct CRWA owned and operated treatment facilities near Dittmar Falls at Lake Dunlap.
- **Purchase treated water from GBRA** - Purchase wholesale treated water from a GBRA owned and operated facility, located near Dittmar Falls at Lake Dunlap.
- **Purchase water from GBRA with treatment by the City of Seguin** - Purchase water from GBRA on a take-or-pay contract and use an existing 2 MGD of excess capacity in the City of Seguin treatment facility until such time as the City needs the capacity. Build additional needed CRWA capacity at Dittmar Falls.
- **Develop well fields in the Carrizo-Wilcox Formation** - Drill a number of wells into the Carrizo-Wilcox Formation south of Seguin. As the formation water is known to contain elevated levels of iron, surface treatment will be required. This plant would be constructed by CRWA near Dittmar Falls.
- **Appropriate surface water downstream of GBRA hydropower dam H-5** - Appropriate unappropriated surface water downstream of GBRA hydropower dam H-5; construct diversion and treatment facilities and pump back to the CRWA service area.

## Conclusions

The conclusions drawn from this study and recommended supply development options are listed below.

### Future Demands

- The CRWA member WSCs are projected to serve an aggregate population in excess of 65,000 persons by the year 2020. Each of the WSCs is expected to serve populations in excess of 17,000 persons within their existing respective service areas (Figure ES-2).
- Using the TWDB High Per Capita Use Series Projections With Water Conservation, the aggregate CRWA water supply demand in the year 2020 is approximately 11,400 AF/yr (10.0 MGD) (Figure ES-3).
- Individually, GWWSC will require a total of 3,608 AF/yr (3.22 MGD); SHWSC will require a total of 2,747 AF/yr (2.45 MGD); CCWSC will require a total of 2,465 AF/yr (2.20 MGD) and ECWSC

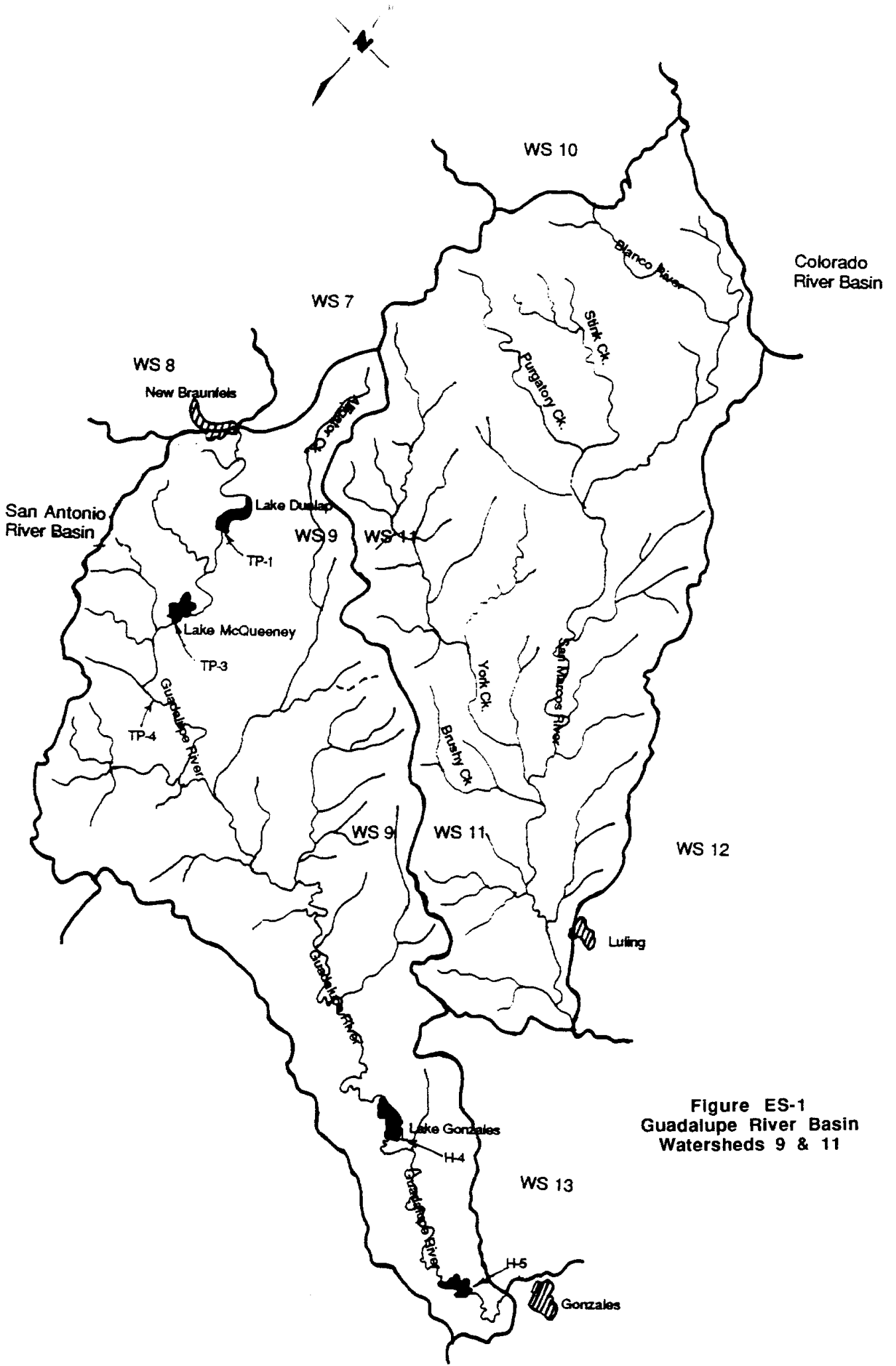

**Figure ES-1**  
**Guadalupe River Basin**  
**Watersheds 9 & 11**

Figure ES-2  
Projected CRWA Member Future Populations  
High Series

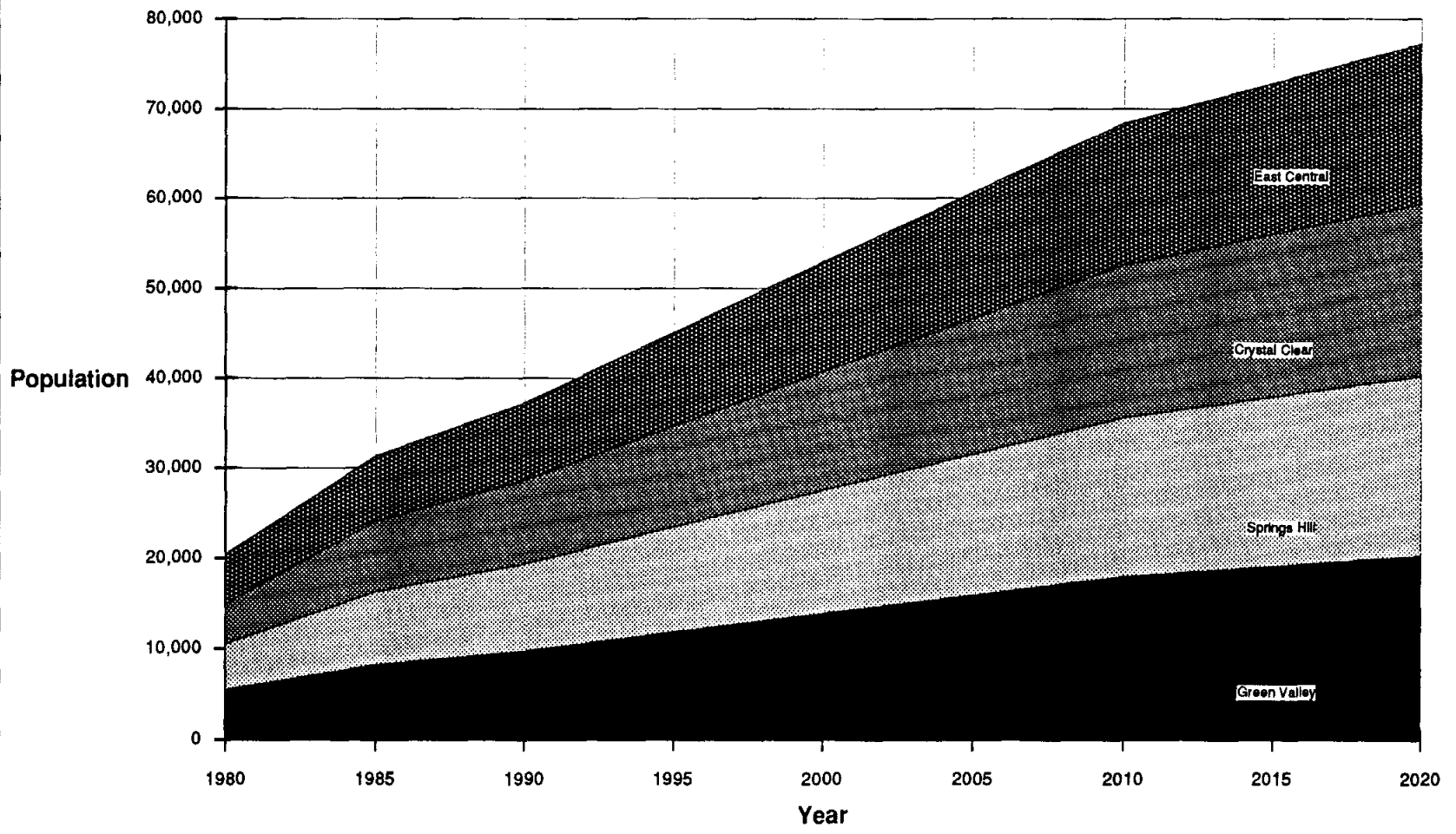
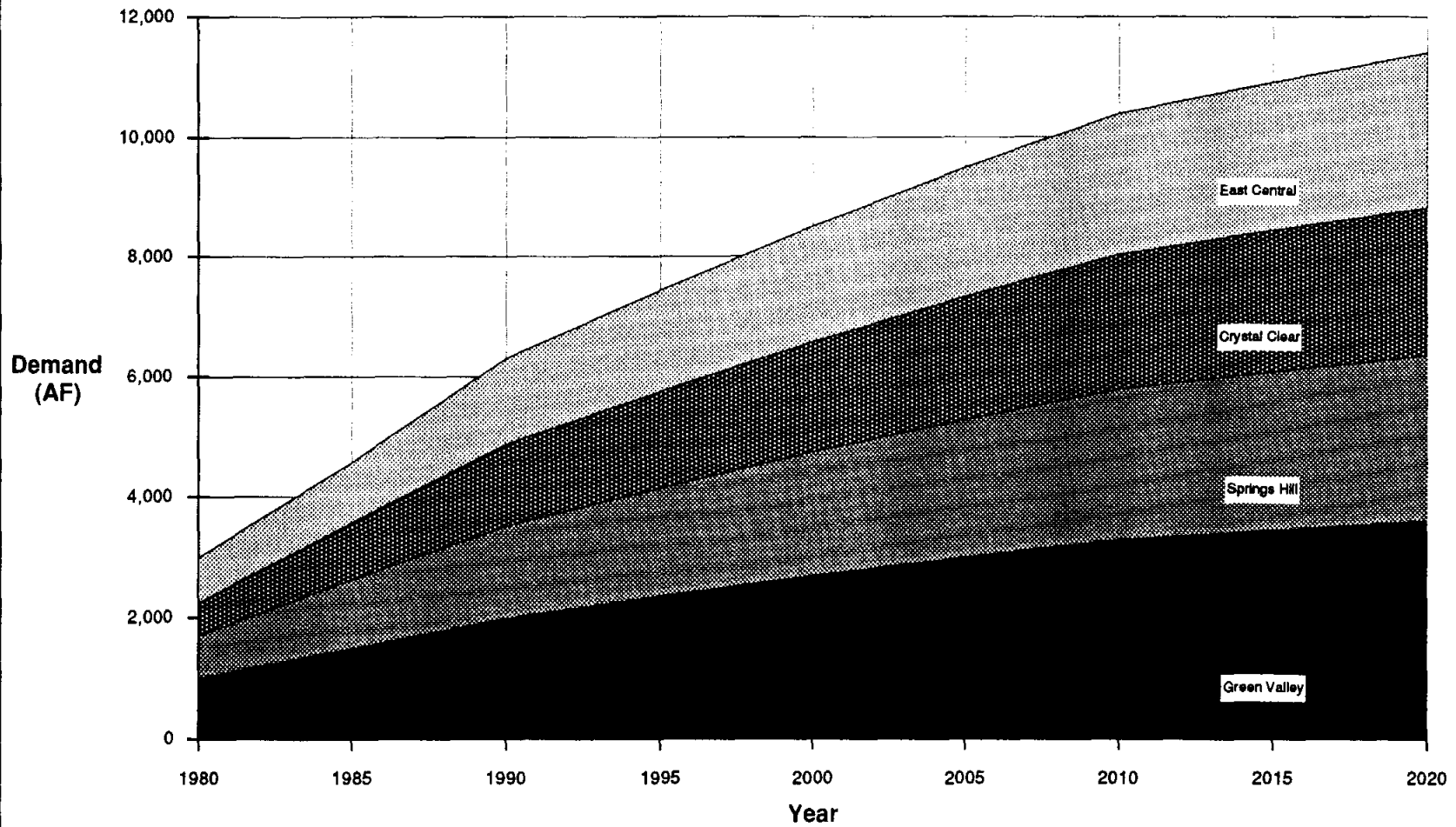



Figure ES-3  
Projected CRWA Member Future Water Demand  
High Population Series - High Per Capita Use - With Conservation



will require a total of 2,585 AF/yr (2.31 MGD) to meet the projected demands ( also Figure ES-3).

- The amount of additional supplies necessary to satisfy the projected demand is the difference between the projected demand and firm supplies from current sources that can be counted on through the 1990-2020 planning period.

## **Future Supplies**

### **Quantities**

- All CRWA members derive all or part of their current water supplies either directly or indirectly from the Edwards Aquifer.
- Under the recently adopted EUWD Drought Management Plan, the firmness of the Edwards Aquifer as a future CRWA supply source is cast into serious doubt. Implementation of Phase I Drought Management demand reduction measures in March 1990 and the apparently inevitable implementation of Phase II management strategies in the summer 1990 underscore the undependable nature of the Edwards Aquifer as a primary future CRWA supply source.
- Projected future firm drought condition for the Probable Case Development Scenario supplies overlain on projected future demands are shown in Figures ES-4 and ES-5. CRWA needs 2.0 MGD of additional firm supply source and treatment capacity immediately with 2.0 MGD incremental source and treatment capacity additions 1995, 2000 and 2015 (Figure ES-6).
- Individually, GVWSC will require 2,855 AF/yr (2.53 MGD); SHWSC will require 1,240 AF/yr (1.11 MGD); CCWSC will require 2,465 AF/yr (2.20 MGD) and ECWSC will require 2,590 AF/yr (2.31 MGD) of additional water supplies to ensure protection of drought condition projected demands through 2020.

### **Sources**

- The Edwards Aquifer remains the least expensive water supply source available to CRWA members and should be utilized, to the maximum extent allowed under existing permits, contracts and supply agreements, as a future CRWA water supply source.
- Future use of the Edwards Aquifer will be subject to the conditions of the EUWD Drought Management Plan and could be strongly affected by proposed legislation that would limit the export of Edwards water to areas not located directly over the aquifer. Continued use of the

Figure ES-4  
 Drought Case Projected CRWA Member Future Water  
 Demand and Supplies

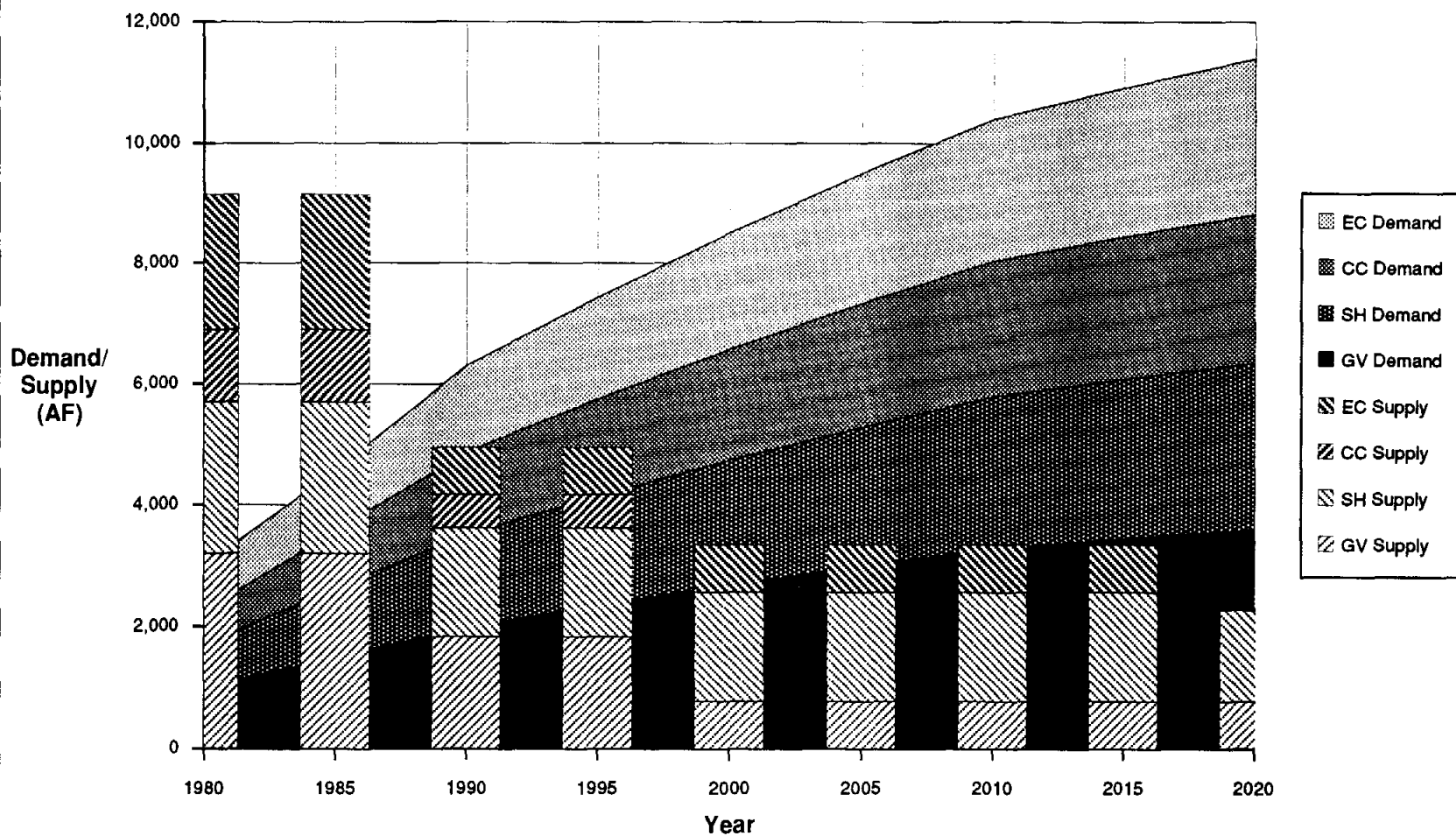

Figure ES-5  
Drought Case Projected CRWA Member Future Water  
Demand and Required Supplemental Supplies

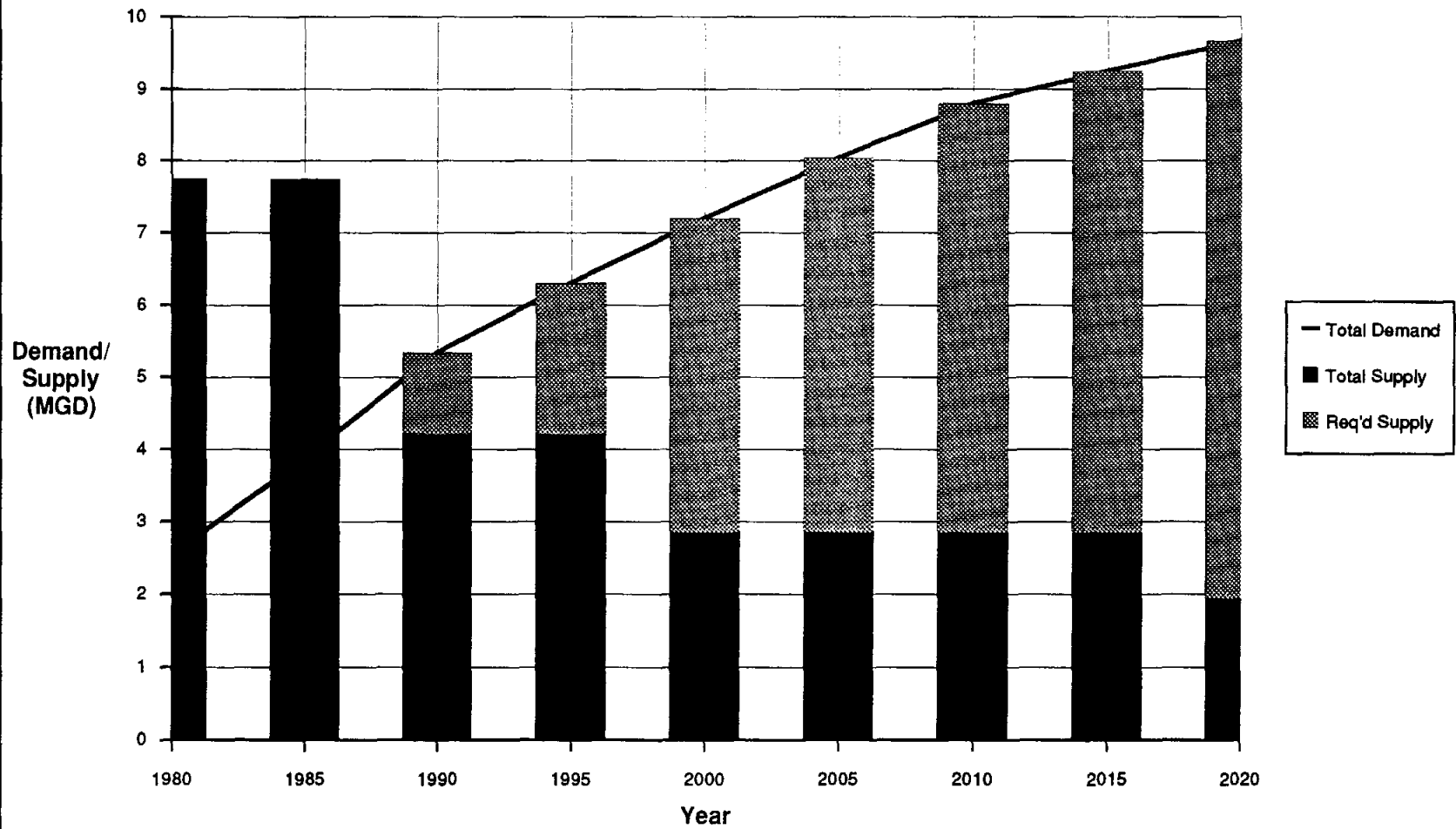

Figure ES-6  
Projected CRWA Member Future Required Supplemental Supplies

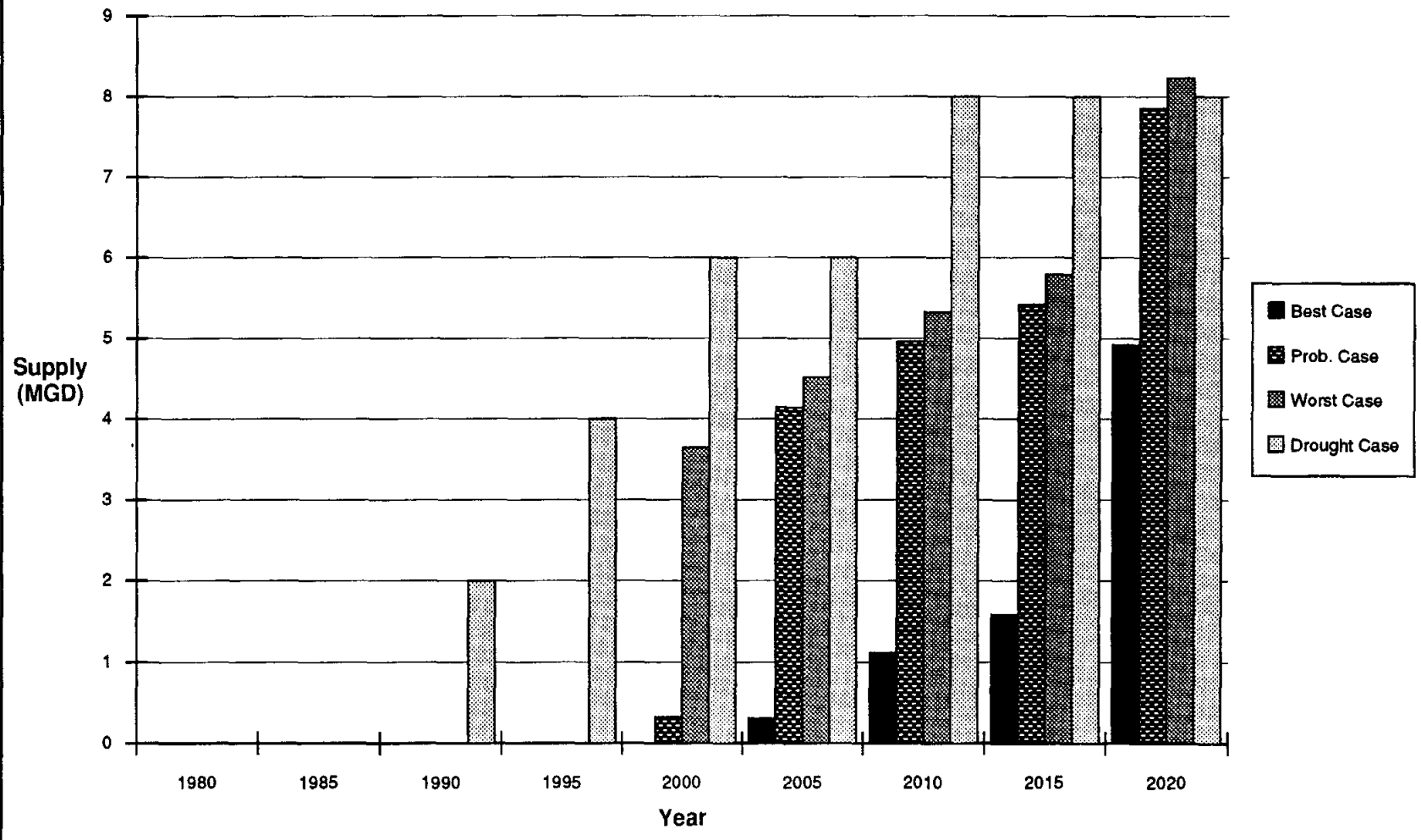
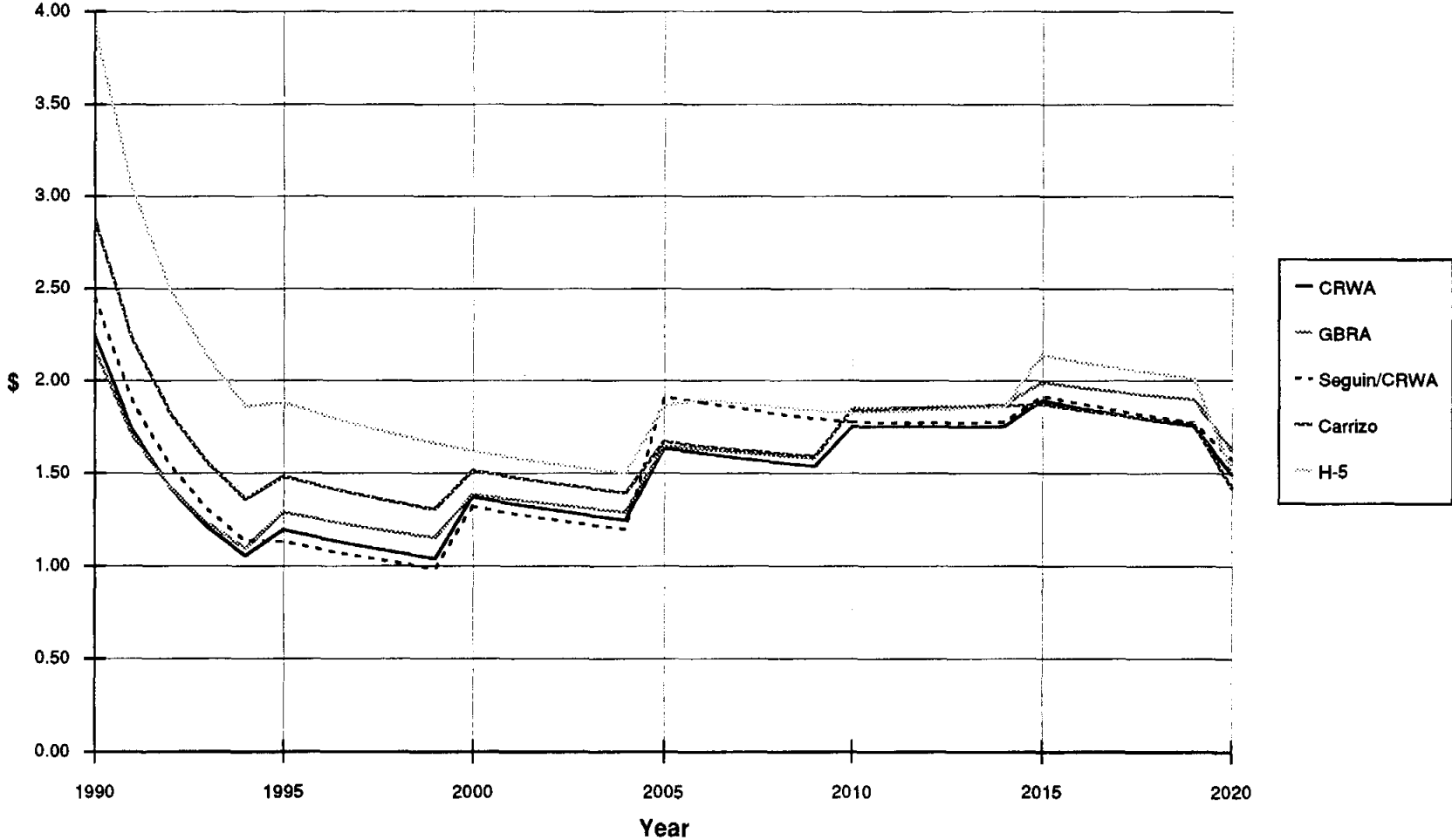

Figure ES-7  
Cost/1,000 gal of Major CRWA Supply Options



Edwards Aquifer as a major supply source is feasible; however, the long-term reliability of this option is doubtful.

- The GBRA holds TWC Non-consumptive Use Hydropower Generation Water Rights Permits for five impoundments between Canyon Reservoir and the City of Gonzales. The Special Conditions of those permits result in an approximate 1,300 cfs minimum flow restriction in this stretch of the Guadalupe River; effectively precluding appropriation of Guadalupe River within the service area water by CRWA except through a Subordination Agreement with the GBRA.
- There are no other firm surface water sources available for appropriation within or near the CRWA service area that would provide a dependable firm supply without expensive on- or off-channel storage.
- Future supply options such as conversion of coastal basin demands to alternative sources, enhancement of the coastal canal conveyance system, conversion of irrigation rights to municipal rights and recharge of local groundwater formations all either fail to provide sufficient future firm supplies or suffer from major development impediments.
- Local shallow wells fail to provide sufficient future supplies to satisfy projected CRWA demands. During drought periods, these meager deposits would receive little or no recharge and would be quickly depleted.
- The Leona and Carrizo-Wilcox formations both contain groundwater supplies that could serve as future sources to CRWA members. Leona Formation water, however, is known to contain high levels of nitrates which are extremely difficult and expensive to remove. In addition, the Leona Formation would probably prove unreliable during severe drought conditions. The Carrizo-Wilcox Formation contains sufficient supplies; however, it also contains elevated levels of iron and manganese which require treatment levels in excess of typical surface water sources.
- Carrizo-Wilcox Formation water should be considered only as a supplemental supply to be blended with other supplies and treated at a surface water treatment facility.
- There are no candidate wastewater sources within or near to the CRWA service area which would provide a cost effective dependable supply for reclamation and reuse.
- Purchase of future supplies from the GBRA and treatment in facilities constructed by either the CRWA or GBRA or use of existing excess capacity of the City of Seguin treatment facility all appear to be feasible and cost effective future CRWA supply and treatment alternatives

(Figure ES-7). Use of excess Seguin treatment capacity, however, would be limited to the present through the year 2005.

### **Recommendations**

- CRWA should institute an aggressive water conservation program with the following elements:
  1. Education and Information
  2. Plumbing Codes
  3. Retrofit Program
  4. Water Rate Structure
  5. Universal Metering
  6. Water Conservation Landscaping
  7. Leak Detection and Repair
  8. Recycle and Reuse
- CRWA should approach the EUWD to ascertain the future of permits which allow transfer of Edwards water off the aquifer. CRWA should request renewals of all existing permits. In addition, CRWA should apply for additional permits sufficient to supply future demands. The outcome of these applications will establish a baseline for development of alternative supplies (Figure ES-8).
- CRWA should enter negotiations with the GBRA to either:
  1. Purchase 4,500 AF/yr from Canyon Reservoir storage through the year 2000 with an option to purchase an additional 4,500 AF/yr beginning in 2000; and begin immediate construction of a new 2.0 MGD water treatment facility near Lake Dunlap; or
  2. Enter into a contractual agreement whereby the GBRA will supply treated water to CRWA in the incremental amounts and times sufficient to meet projected future drought condition firm supply needs.
- Distribution system construction should be phased to reflect short- and long-term future CRWA development options.
  1. CRWA should begin construction of a short-term future water distribution system that will deliver supplies to all potential customers through the year 2005.



Figure ES-8  
Cost/1,000 gal For Each WSC - CRWA Treatment Option

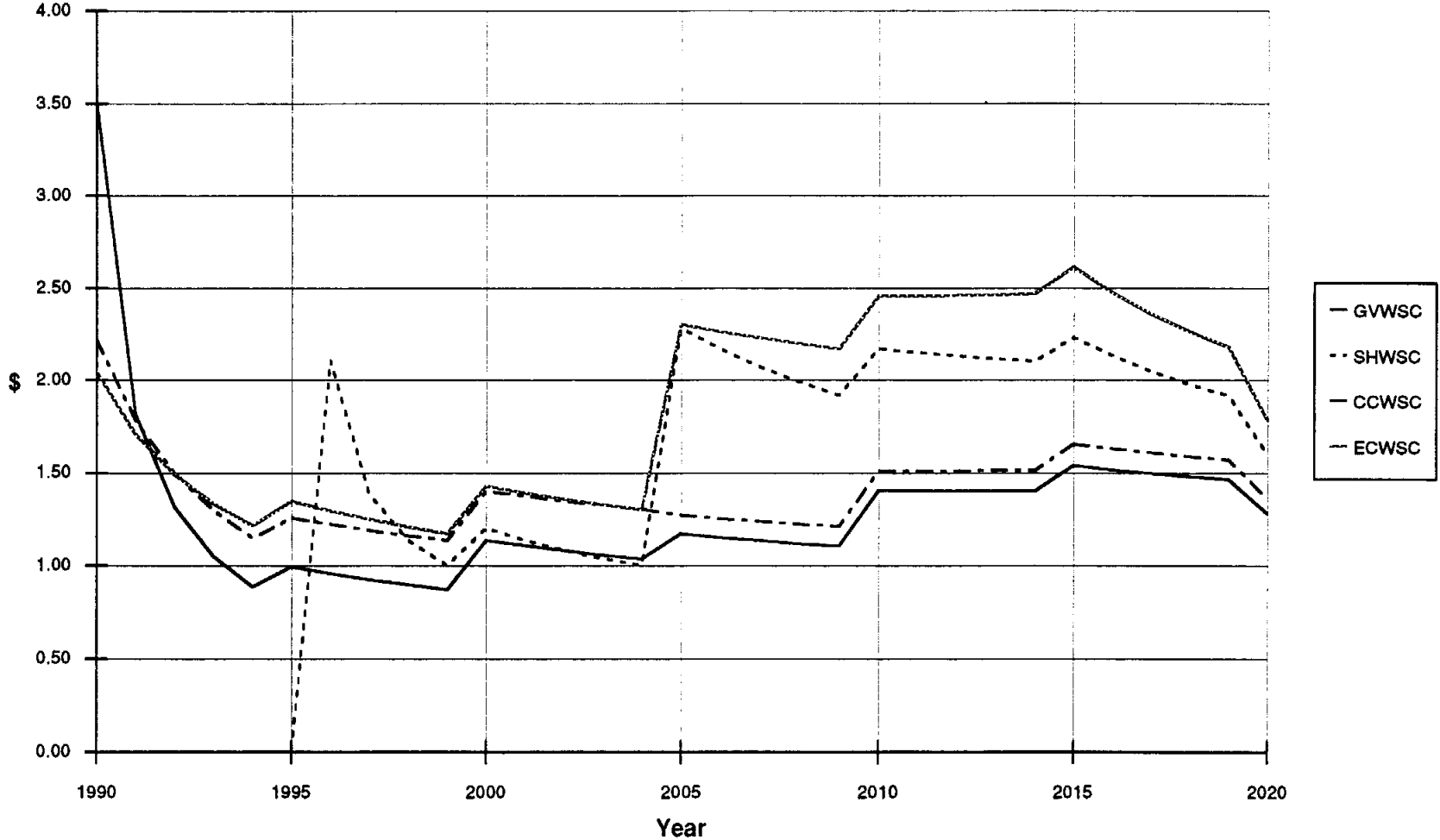

2. Long-term future distribution system decisions should be deferred until such time as the future demand and distribution scenarios identified in this report are either verified or superseded with updated estimates.

- The short-term CRWA treated water distribution system should resemble that depicted in Figure ES-9.
- The CRWA should pursue financing options that would reduce or ameliorate the "rate shock" resulting from immediate high capital expenditures when the rate payor base is relatively low.

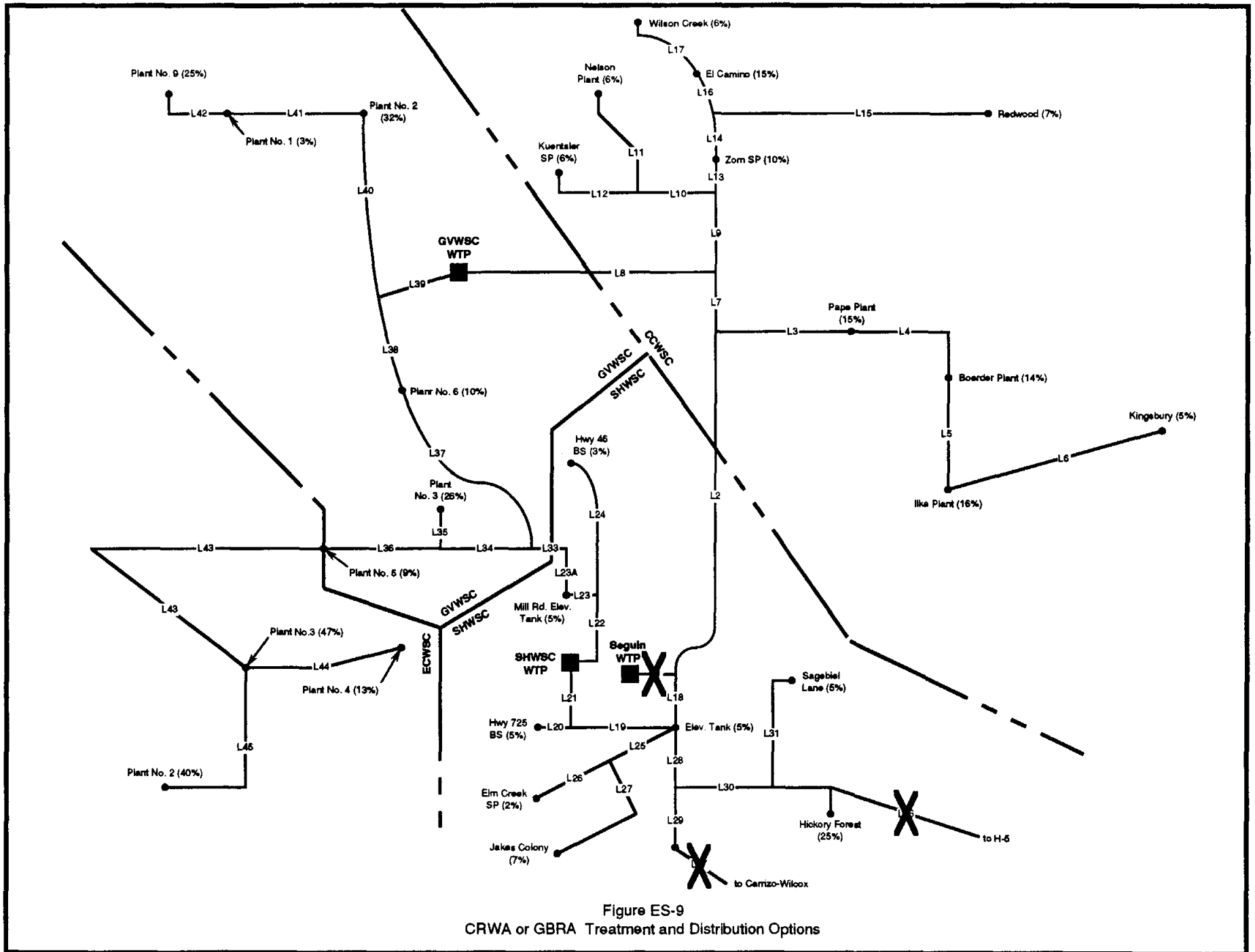

Figure ES-9  
CRWA or GBRA Treatment and Distribution Options

## **1.0 INTRODUCTION**

### **1.1 Authorization**

In recent years the City of San Antonio and surrounding areas have experienced rapid growth and industrial development. As a result, the Edwards Aquifer which serves as the principal water supply source for the region has been subjected to increasing levels of stress both from higher withdrawals and diminution of water quality resulting from polluted point or nonpoint source recharge. The Texas Water Development Board (TWDB) and Edwards Underground Water District (EUWD) have each implemented programs to protect the Edwards Aquifer as a future dependable and high quality supply source for all users in the area. To that end the TWDB and EUWD are currently encouraging transport pumpers, i.e., those users whose service areas are not located directly over the Edwards Aquifer, to begin investigating alternative sources to satisfy future demands. In addition, the EUWD has enacted a drought management plan that will severely restrict availability of Edwards Aquifer water to all users in the event of a severe or prolonged drought. Thus it is imperative that all Edwards Aquifer water users begin to examine potential supplementary or alternative water sources.

The TWDB, through its continuing Regional Water and Wastewater Planning Grant Program, has identified the area to the northeast and east of San Antonio as typical of Edwards Aquifer user systems that should begin securing alternative future water sources. This study, financed in part by the TWDB, was initiated as a result of House Bill 2 and House Joint Resolution 6, passed by the 65th Texas Legislature in 1985, in order to encourage cost-effective regional water and wastewater facility development.

The Canyon Regional Water Authority (CRWA) was created in response to the expressed intentions of the TWDB and EUWD to limit pumpage from the Edwards Aquifer for all users and to encourage development of alternative future sources for those users not located directly over the aquifer. The CRWA is comprised of four water supply corporations (WSCs); Green Valley, Crystal Clear, Springs Hill and East Central. All four WSCs derive all or part of their water supplies either directly or indirectly from the Edwards Aquifer. The combined serve area of the CRWA member WSCs measures approximately 618 square miles and covers nearly all of Guadalupe County, a large portion of Bexar County, and smaller portions of Hays, Wilson and Comal Counties.

The CRWA applied for and was awarded a 50% matching fund TWDB Planning Grant to develop a regional plan to supply the future water needs of the service area. Of primary interest was the investigation of supplies alternative to the Edwards Aquifer. Accordingly, the CRWA contracted with the consortium Michael Sullivan and Associates, Inc., Gebhard Engineering, Inc. and Abbe/Garrett Engineering, Inc. to perform this regional water supply study.

## 1.2 Objectives and Scope

The study area for this study was limited to the service area of the four CRWA member WSCs. Under the terms of the TWDB Planning Grant, the CRWA could plan for additional surrounding areas and cities within the service area; however, efforts to enlist the interest and support of additional future members or potential wholesale water customers was fruitless. Therefore, all demand and supply projections of this study are confined to the needs of the current CRWA service area.

The objective of this study was to project, through the year 2020, populations and supply demands of the four WSCs and then to identify feasible future supply and treatment development alternatives sufficient to supply those demands. Special emphasis was placed on alternatives that would minimize dependence on the Edwards Aquifer as a primary supply source. Infrastructure development was limited to major transmission and distribution systems and WSC interconnects that would ensure an equitable supply to all users under drought conditions.

The scope of this study is outlined below:

### Task 1 Evaluate Existing Surface and Groundwater Sources

- A. Analyze quantity and quality of existing surface water and groundwater sources.
- B. Evaluate impacts of growth on available surface water and groundwater sources.

### Task 2 Develop Population and Water Demand Projections

- A. Develop population and economic growth projections for the portions of Guadalupe, Bexar, Comal, Wilson and Hays County service areas in the planning region, by five-year intervals, from 1990 to 2020.
- B. Using TWDB methodologies and data, provide and evaluate high and low water demand for major user classes in the service area from 1990 to 2020.

### Task 3 Evaluate Environmental Considerations

- A. Identify and evaluate potential biological impact on aquatic and terrestrial ecosystems.
- B. Evaluate potential water quality impacts.
- C. Identify and evaluate potential archaeological impacts.

### Task 4 Identify Potential Water Sources and Treatment Plant Sites

- A. Develop a list and conduct a preliminary screening of potential water sources and sites.
- B. Identify water sources and sites for further evaluation and screening.

### Task 5 Evaluate Water Treatment and Distribution Alternatives

- A. Prepare and select development scenarios for the service area including modification to existing operation.

CANYON REGIONAL WATER SUPPLY STUDY  
INTRODUCTION

- B. Based on projected water demands, develop evaluation and sizing of water treatment and distribution systems for the service area.
- C. Estimate capital and operation and maintenance costs for water treatment plants and distribution systems for each alternative.

Task 6 Evaluate Alternative Water Supply Options and Develop Long-term Water Supply Planning Recommendations

- A. Evaluate alternative water supply scenarios for the service area.
- B. Develop and recommend most feasible long-term water supply planning alternatives.
- C. Prepare cost estimates by implementation phase over the 30-year planning period.

Task 7 Develop Institutional and Legal Considerations and Financial Plan for Potential Alternatives

- A. Analyze institutional and legal considerations and prepare a financial plan for potential alternatives, including steps to be used to plan, finance, develop, operate, and maintain the selected system.
- B. Develop a schedule with time frames for project implementation, including required facility component sizes, initial capital costs, operation and maintenance, and cash flow estimates for respective phases.

Task 8 Develop Water Conservation and Drought Management Plans

- A. Develop a water conservation plan for the planning area to emphasize the efficient use of water resources.
- B. Submit a draft water conservation plan to the Board for review.
- C. Develop a drought management plan for the service area, including objective standards to determine existence of drought conditions, establishment of water demand reduction goals, and delineation of water demand reduction measures for defined stages of drought severity.

Task 9 Prepare and Submit Draft and Final Reports

### 1.3 Contents of Report

This report is divided into eight additional sections. Sections are not arranged in the exact order of the project scope task description; but, contain all essential components of that scope.

Section 2 Existing Conditions - Description of physical features of the study area; historical and current populations, water demands and sources; and existing treatment capacities and infrastructure.

Section 3 Population and Water Demand Projections - Projection of future populations and water demands and selection of future development planning scenarios.

Section 4 Water Conservation Plan - Description of long-term water conservation plan elements and implementation and enforcement mechanisms.

Section 5 Future Development Planning Scenarios - Description of future supply conditions, development assumptions and projected demands.

CANYON REGIONAL WATER SUPPLY STUDY  
INTRODUCTION

- Section 6 Preliminary Water Supply Option Evaluation - Description of scope of supply option search, selection criteria, evaluation criteria, potential options, screening matrix evaluation and options recommended for detailed evaluation.
- Section 7 Detail Cost Evaluation - Description of proposed phased improvements, construction costs, supply and treatment costs, storage and pumping requirements, and transmission systems.
- Section 8 Institutional and Legal Considerations - Description of rights of way acquisition, water rights, intergovernmental contracting methods and regional water supply implications.
- Section 9 Conclusions and Recommendations.

## 2.0 EXISTING CONDITIONS

### 2.1 Physical Features of Study Area

#### 2.1.1 Geographical Location

The study area consists of most of Guadalupe County, the eastern part of Bexar County and smaller portions of Comal, Hays and Wilson Counties (Figure 2-1). The majority of the area is situated in the Guadalupe River Basin. However, Cibolo Creek, which drains part of the San Antonio River Basin, delineates the boundary between Guadalupe and Bexar Counties.

The vast majority of the study area lies south of IH 35. The northeastern boundary is the San Marcos River, which delineates the boundary between Guadalupe and Caldwell Counties. To the west is the City of San Antonio, which currently provides water to part of the study area. The area is dissected by IH 10. In addition to San Antonio, major cities in the area are Schertz and New Braunfels on IH 35 and Seguin and Luling on IH 10.

This study area is within the Austin-San Antonio growth corridor and has experienced rapid rates of growth and economic development in the last two decades. Because of this rapid growth, and because the area receives somewhat limited and often erratic precipitation, the whole Central Texas area is concerned about its long-term water supply, which could, if improperly managed, constrain growth in the foreseeable future.

Several studies relating to long-term water resource planning have been carried out in the past. Much of the impetus for these studies has derived from a desire to prevent overdrafting of the Edwards Aquifer, the primary water supply for much of the region, and the desire on the part of San Antonio to ensure adequate water supplies in the future. These studies have often treated the Guadalupe and San Antonio River Basins as a single planning unit, with the primary goal of diverting water to the City of San Antonio. Both rivers run east and southeast, converging 11 miles prior to discharging into San Antonio Bay.

#### 2.1.2 Geology

The study area lies within the eastern portion of the Comanche Shelf, separated from the ancestral Gulf of Mexico Basin by the Stuart City Reef. The shelf consisted of a flat, generally submerged plain upon which Lower Cretaceous rocks were deposited. The top of the Lower Cretaceous dips southeast at about 300-400 feet per mile, interrupted by several fault zones. Where the coastward-dipping Edwards reservoir was pushed against less permeable Upper Cretaceous limestone and clay, several oil fields were formed.

Following several alternating periods of exposure and flooding by shallow open seas, the Comanche Shelf was finally submerged during the late Washita. As sea level rose, the area was first partially covered



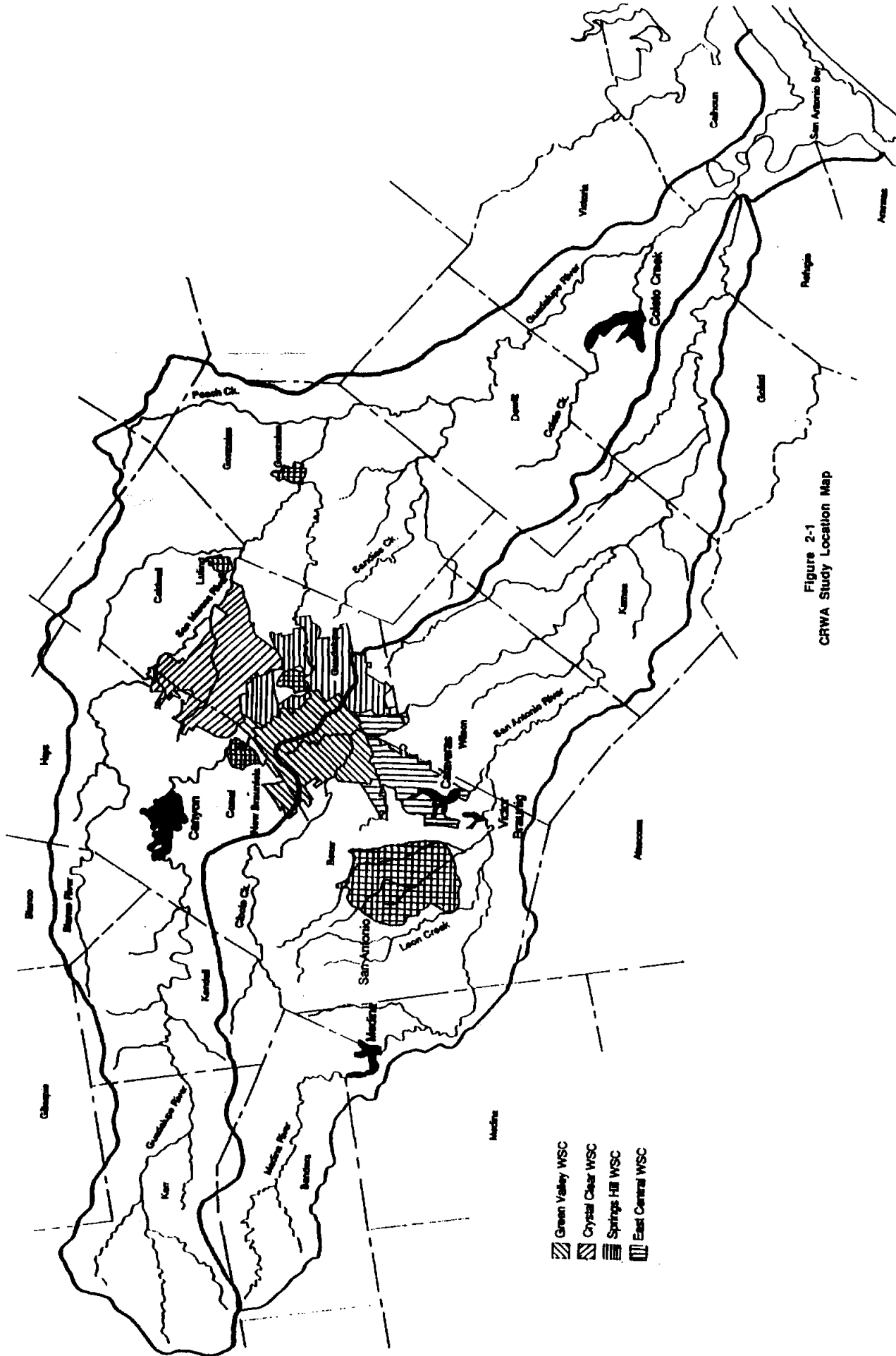

Figure 2-1  
CRWA Study Location Map

CANYON REGIONAL WATER SUPPLY STUDY  
EXISTING CONDITIONS

with a thin layer of lime mud (Georgetown Formation). This was followed by deposition of marine terrigenous sediment, mostly clay, known as Del Rio Clay. Finally a thin sheet of open-shelf lime (Buda Limestone) blanketed the entire area.

The principal geologic features in the study area are the Balcones Fault Zone and the Luling Fault Zone. The Balcones Fault Zone consists of a series of semi-parallel faults about 15 miles wide, extending from Hays County southwest to Bexar County and encompassing the route of IH 35. Ten to 20 miles southeast of this fault zone, extending in a roughly parallel belt, is the Luling Fault Zone. Total throw of the Balcones Fault Zone ranges from 900 feet near Austin to 1200 feet in Bexar County. The Luling Fault is less extensive with a throw of 450 feet.

Northeast of the fault zone is the Edwards Plateau, covered by Edwards limestone except where it has been dissected by the Guadalupe and San Antonio Rivers. The lower 50 to 75 feet is quite porous and because it overlies the impervious Glen Rose Formation, forms a widespread aquifer. Permanent springs issue from the base of the Edwards; caverns and sinkholes are common.

#### 2.1.3 Climate

The area lies within the south-central climatological region, characterized by a modified sub-tropical climate. Typically, temperatures range from the low 50s to the mid 80s, with an average of 18 days per year with below-freezing temperatures. In Seguin the average rainfall annually is 30 inches, however, this can vary considerably from year-to-year. Within the period of record, 15 inches was recorded for 1925 and 49.5 inches for 1949 (NOAA in Bureau of Reclamation study). Precipitation often falls in the form of heavy storms, which can occur throughout the year, making the area one of the most flood-prone in the nation. Prevailing winds during the warmer months are southeasterly, resulting in relative humidities of 50 to 80 percent.

#### 2.1.4 Hydrology

The main water course in the area is the Guadalupe River. It originates in Kerr County on the Edwards Plateau and flows southeast some 350 miles to the Gulf of Mexico. Its main tributary is the San Marcos River, which originates from springs within the City of San Marcos, and joins the Guadalupe River near Gonzales. Also within the study area, Cibolo Creek originates in Bandera County and joins the San Antonio River in Karnes County. Both the Guadalupe and San Antonio Rivers discharge into Guadalupe Estuary.

All of the water courses in the region are replenished by surface runoff and the two major aquifers, the Edwards Plateau and the Edwards underground reservoir. The Edwards Plateau aquifer, situated under the Edwards Plateau, is composed mainly of Edwards limestone and provides the base flow for streams

that drain the Edwards Plateau. It extends to the Balcones Escarpment, which marks the beginning of Edwards underground reservoir. As the streams cross the escarpment, most of the flow is lost, the Balcones Fault Zone providing the major recharge area for the Edwards underground reservoir.

The Balcones Fault Zone allows free circulation of ground water through a series of channels and caverns. The southerly movement of water is blocked by the major faults and decreases permeability of the rock formations, resulting in a predominantly easterly and northeasterly flow. The lowest natural outlet for the aquifer is San Marcos Springs, approximately 50 feet lower than Comal Springs. These two springs supply a substantial portion of the base flow of the Guadalupe River; average rainfall amounting to approximately 25 percent of river flow is measured at Cuero (CH2M Hill 1986).

For the period of record (1934-1982), recharge to the aquifer has averaged 608,000 acre-feet per year. However, the last 14 of these years have been particularly wet, resulting in levels of recharge approximately 40 percent higher than average (CH2M Hill 1986). In 1982, total discharge was 786,000 acre-feet, of which well discharge accounted for 453,000 acre-feet. It has been calculated that, at this level of pumpage, a return to average recharge conditions would result in a reduction of the combined discharge from San Marcos and Comal Springs to 135,000 acre-feet per year (40 percent of their 1978-1982 levels) (CH2M Hill 1986).

Most of the study area is underlain by the Carrizo-Wilcox Aquifer, where fresh to slightly saline water is available. The Carrizo Sand formation, which overlies the Wilcox Group, is estimated by TWDB to receive approximately 100,000 acre-feet per year recharge. TWDB considers that, with proper management, withdrawals can continue to exceed this amount, at least to the year 2020 (CH2M Hill 1986).

#### 2.1.5 Ecological Features

The study area lies within the Texan biotic province. With predominantly pedalfer soils, the area supports both blackland prairies and post oak woodlands. Both areas have been heavily impacted by grazing. Blackland prairies are associated with uniform, dark-colored calcareous clays interspersed with gray acid sandy loams. Little bluestem is considered the climax dominant vegetation but, together with other native grasses, is largely replaced in heavily grazed areas.

Post oak savannah occurs in areas of acid sandy loams containing varying amounts of sand and clay, depending upon the elevation. The dominant species is post oak, which occurs in open stands surrounded by grasses. More recently, much of the area has been replaced by dense woodland stands of post oak and winged elm, which are often cleared to promote grazing.

Along the Guadalupe River the vegetation type depends on the characteristics of the floodplain. Along minor streams, a narrow band of riparian forest is typical. Wider floodplains are characterized by

forests with a dense overstory and a well-developed understory and shrub layer. Because the lower levels are frequently flooded, terracing of vegetation is common. Significant increases in the withdrawal of water from the river could adversely impact these ecosystems.

Another system sensitive to greater surface water use and/or additional impoundments is the bay and estuary community. Freshwater inflows to bays and estuaries, particularly at certain times of the year, are critical to maintain salinity levels and provide nutrients. The majority of Gulf fish and shellfish are dependent upon the Texas bays and estuaries at some point in their life cycle. Both the Guadalupe and San Antonio Rivers discharge into Guadalupe Estuary, contributing an average of 1.81 million acre-feet between 1941 and 1976. TWDB estimates that, of this, 1.62 million acre-feet are required to maintain commercial fishery harvests at average historic levels (Water for Texas v. 1).

## **2.2 Populations, Water Demands and Sources**

### **2.2.1 Current Conditions**

The current population of the CRWA Service Area is approximately 36,500 persons. Table 2-1 provides a 1989 accounting of population, service connections, and average and maximum daily system usage for each CRWA member Water Supply Corporations (WSCs). Though the service areas of the four WSCs vary, the populations of each service area vary less than 2,000 persons from largest to smallest. Green Valley currently serves the largest number of customers (10,998), followed by Springs Hill (9,244), Crystal Clear (8,349) and East Central (7,998). Variations in average daily water use and per capita also vary little between WSCs. Green Valley has the highest daily use as well as the highest per capita use rate; however, East Central, has the second highest per capita use rate which accounts for its high daily average total use rate. Green Valley has a markedly lower than average number of persons per service connection. Green Valley has approximately 2.6 persons per connection while all three other WCS have approximately 3.0 persons per tap.

### **2.2.2 Historical Uses**

TWDB records were examined to establish historical use patterns for each WSC. Monthly data was used to establish such variables as: total water self-supplied and purchased; maximum and minimum use months; maximum to average month use ratios; and rates of consumption per service connection. These data will be important in the design phase of future growth planning for the CRWA.

Table 2-2 and Figure 2-2 show that Green Valley WSC (GVWSC) water use rates started to increase dramatically around 1979. Interstate Highway 10 cutting directly through the Green Valley WSC service area and development of New Braunfels as a San Antonio satellite bedroom community, most likely

Table 2-1  
CRWA Member WSC Populations and Water Uses

<b>Green Valley Water Supply Corporation</b>					
Population Served				10,998	
Total Connections				4,189	
Average Daily Use (MGD)				1.781	
Maximum Daily Use (MGD)				1.900	
<b>Springs Hill Water Supply Corporation</b>					
Population Served				9,244	
Total Connections				3,088	
Average Daily Use (MGD)				0.766 (suspect = 1.261 corrected†)	
Maximum Daily Use (MGD)				1.668	
<b>Crystal Clear Water Supply Corporation</b>					
Population Served				8,349	
Total Connections				2,783	
Average Daily Use (MGD)				1.003	
Maximum Daily Use (MGD)				-	
<b>East Central Water Supply Corporation</b>					
Population Served				7,998	
Total Connections				2,666	
Average Daily Use (MGD)				1.187	
Maximum Daily Use (MGD)				-	
<b>Summary</b>					
Supply Corporation	Population	Number Connections	Persons Per Connection	Average Daily Use (MGD)	Avg. Daily Per Cap. Use (gcd)
Green Valley	10,998	4,189	2.63	1.781	162
Springs Hill	9,244	3,088	2.99	1.261	136
Crystal Clear	8,349	2,783	3.00	1.003	120
East Central	7,998	2,666	3.00	1.187	148
<b>Total</b>	<b>36,589</b>	<b>12,726</b>		<b>5.232</b>	
<b>Average</b>			<b>2.91</b>		<b>141.5</b>

† 10-year average use/connection = 408.49 gal/conn/day => based on 3,008 taps, average use = 1.261 MGD.

Table 2-2  
Green Valley Water Supply Corporation Historical Use

Year	January			February			March			April			May			June		
	Self. a/	Purch. b/	Total	Self. a/	Purch. b/	Total	Self. a/	Purch. b/	Total	Self. a/	Purch. b/	Total	Self. a/	Purch. b/	Total	Self. a/	Purch. b/	Total
1966	6.8	0.0	6.8	6.6	0.0	6.6	7.4	0.0	7.4	8.3	0.0	8.3	8.6	0.0	8.6	15.0	0.0	15.0
1967	10.7	0.0	10.7	9.5	0.0	9.5	12.6	0.0	12.6	12.6	0.0	12.6	15.0	0.0	15.0	18.7	0.0	18.7
1968	13.5	0.0	13.5	11.7	0.0	11.7	14.1	0.0	14.1	12.0	0.0	12.0	14.1	0.0	14.1	13.5	0.0	13.5
1969	11.0	0.0	11.0	13.5	0.0	13.5	14.1	0.0	14.1	13.8	0.0	13.8	15.3	0.0	15.3	19.6	0.0	19.6
1970	16.9	0.0	16.9	14.1	0.0	14.1	15.7	0.0	15.7	15.0	0.0	15.0	19.0	0.0	19.0	21.5	0.0	21.5
1971	18.7	0.0	18.7	19.9	0.0	19.9	23.9	0.0	23.9	25.8	0.0	25.8	27.9	0.0	27.9	29.2	0.0	29.2
1972	21.5	0.0	21.5	26.1	0.0	26.1	26.7	0.0	26.7	27.6	0.0	27.6	30.7	0.0	30.7	30.7	0.0	30.7
1973	31.0	0.0	31.0	21.5	0.0	21.5	30.7	0.0	30.7	24.6	0.0	24.6	37.4	0.0	37.4	37.4	0.0	37.4
1974	31.0	0.0	31.0	30.7	0.0	30.7	35.9	0.0	35.9	41.7	0.0	41.7	39.3	0.0	39.3	46.6	0.0	46.6
1975	27.6	0.0	27.6	31.6	0.0	31.6	34.1	0.0	34.1	37.7	0.0	37.7	38.4	0.0	38.4	38.4	0.0	38.4
1976	35.0	0.0	35.0	36.8	0.0	36.8	42.0	0.0	42.0	33.8	0.0	33.8	35.9	0.0	35.9	49.1	0.0	49.1
1977	37.7	0.0	37.7	40.8	0.0	40.8	40.5	0.0	40.5	39.9	0.0	39.9	44.8	0.0	44.8	60.2	0.0	60.2
1978	45.4	0.0	45.4	40.8	0.0	40.8	38.4	0.0	38.4	65.4	0.0	65.4	70.0	0.0	70.0	71.5	0.0	71.5
1979	59.8	0.0	59.8	50.3	0.0	50.3	49.7	0.0	49.7	56.5	0.0	56.5	68.7	0.0	68.7	76.4	0.0	76.4
1980	54.6	0.0	54.6	58.0	0.0	58.0	77.0	0.0	77.0	82.9	0.0	82.9	67.5	0.0	67.5	116.0	0.0	116.0
1981	76.1	0.0	76.1	67.5	0.0	67.5	72.1	0.0	72.1	77.9	0.0	77.9	80.4	0.0	80.4	93.6	0.0	93.6
1982	70.6	0.0	70.6	76.7	0.0	76.7	65.1	0.0	65.1	75.8	0.0	75.8	67.5	0.0	67.5	56.8	0.0	56.8
1983	82.6	0.0	82.6	65.4	0.0	65.4	68.4	0.0	68.4	82.2	0.0	82.2	103.1	0.0	103.1	101.9	0.0	101.9
1984	118.8	0.0	118.8	91.8	0.0	91.8	87.8	0.0	87.8	100.7	0.0	100.7	138.1	0.0	138.1	143.6	0.0	143.6
1985	67.2	21.5	88.7	85.3	19.3	104.6	80.1	29.5	109.6	66.0	33.5	99.5	79.8	34.7	114.5	110.8	32.8	143.6
1986	73.7	28.5	102.2	70.6	25.2	95.8	94.8	33.8	128.6	139.0	27.3	166.3	89.6	27.3	116.9	98.2	36.5	134.7
1987	58.6	2.9	61.5	41.7	32.5	74.2	43.0	34.7	77.7	126.1	45.1	171.2	103.4	41.1	144.5	90.8	43.0	133.8
1988	108.0	34.1	142.1	84.4	29.2	113.6	109.6	35.9	145.5	136.3	41.4	177.7	78.9	48.2	127.1	152.8	57.7	210.5

Year	July			August			September			October			November			December		
	Self. a/	Purch. b/	Total	Self. a/	Purch. b/	Total	Self. a/	Purch. b/	Total	Self. a/	Purch. b/	Total	Self. a/	Purch. b/	Total	Self. a/	Purch. b/	Total
1966	18.4	0.0	18.4	15.3	0.0	15.3	12.0	0.0	12.0	12.3	0.0	12.3	11.4	0.0	11.4	10.7	0.0	10.7
1967	20.6	0.0	20.6	21.8	0.0	21.8	13.8	0.0	13.8	13.5	0.0	13.5	12.3	0.0	12.3	12.0	0.0	12.0
1968	16.6	0.0	16.6	21.2	0.0	21.2	12.9	0.0	12.9	12.9	0.0	12.9	12.0	0.0	12.0	10.7	0.0	10.7
1969	27.9	0.0	27.9	23.9	0.0	23.9	19.0	0.0	19.0	16.0	0.0	16.0	14.7	0.0	14.7	15.0	0.0	15.0
1970	26.4	0.0	26.4	27.9	0.0	27.9	24.6	0.0	24.6	18.4	0.0	18.4	18.4	0.0	18.4	18.4	0.0	18.4
1971	36.2	0.0	36.2	25.8	0.0	25.8	21.8	0.0	21.8	19.9	0.0	19.9	18.4	0.0	18.4	18.4	0.0	18.4
1972	32.2	0.0	32.2	33.8	0.0	33.8	33.8	0.0	33.8	28.8	0.0	28.8	26.4	0.0	26.4	27.0	0.0	27.0
1973	35.9	0.0	35.9	39.9	0.0	39.9	33.8	0.0	33.8	32.2	0.0	32.2	30.7	0.0	30.7	31.0	0.0	31.0
1974	62.0	0.0	62.0	48.5	0.0	48.5	35.3	0.0	35.3	41.4	0.0	41.4	35.3	0.0	35.3	33.8	0.0	33.8
1975	48.5	0.0	48.5	51.6	0.0	51.6	47.6	0.0	47.6	44.8	0.0	44.8	38.1	0.0	38.1	34.7	0.0	34.7
1976	45.4	0.0	45.4	67.5	0.0	67.5	45.1	0.0	45.1	37.7	0.0	37.7	40.2	0.0	40.2	39.0	0.0	39.0
1977	81.0	0.0	81.0	79.8	0.0	79.8	56.8	0.0	56.8	54.6	0.0	54.6	48.8	0.0	48.8	45.1	0.0	45.1
1978	92.1	0.0	92.1	71.2	0.0	71.2	59.2	0.0	59.2	66.0	0.0	66.0	54.6	0.0	54.6	55.2	0.0	55.2
1979	73.3	0.0	73.3	73.7	0.0	73.7	76.7	0.0	76.7	66.3	0.0	66.3	66.0	0.0	66.0	51.3	0.0	51.3
1980	155.3	0.0	155.3	125.2	0.0	125.2	95.1	0.0	95.1	73.7	0.0	73.7	75.8	0.0	75.8	67.8	0.0	67.8
1981	138.1	0.0	138.1	123.7	0.0	123.7	95.1	0.0	95.1	81.6	0.0	81.6	69.4	0.0	69.4	70.6	0.0	70.6
1982	52.8	0.0	52.8	163.9	0.0	163.9	132.6	0.0	132.6	117.2	0.0	117.2	124.6	0.0	124.6	83.8	0.0	83.8
1983	93.6	0.0	93.6	124.9	0.0	124.9	138.4	0.0	138.4	141.2	0.0	141.2	105.6	0.0	105.6	86.2	0.0	86.2
1984	139.6	0.0	139.6	146.4	24.9	171.3	131.7	41.4	173.1	96.1	35.3	131.4	79.2	35.0	114.2	69.7	29.8	99.5
1985	83.5	37.4	120.9	94.5	46.3	140.8	140.9	31.6	172.5	111.1	25.5	136.6	91.8	26.4	118.2	102.5	25.5	128.0
1986	178.9	43.0	221.9	142.7	50.3	193.0	116.9	58.9	175.8	114.2	57.1	171.3	83.8	28.8	112.6	105.6	36.5	142.1
1987	113.2	51.6	164.8	181.4	44.2	225.6	124.9	39.9	164.8	138.1	48.2	186.3	360.6	44.8	405.4	88.4	34.1	122.5
1988	151.0	41.1	192.1	129.0	164.5	293.5	131.3	41.4	172.7	135.0	39.9	174.9	131.3	34.7	166.0	111.4	28.8	140.2

a/ Self-Supplied Ground & Surface  
b/ Purchased from City of New Braunfels

Table 2-2 (Continued)  
Green Valley Water Supply Corporation Historical Use

	Self-Supplied					Purchased					Total Used					No. Taps	Annual Use	
	Total AF	Max. AF	Min. AF	Avg. AF	Max/Avg.	Total AF	Max. AF	Min. AF	Avg. AF	Max/Avg.	Total AF	Max. AF	Min. AF	Avg. AF	Max/Avg.		AF/Tap	gal./Tap
1966	132.8	18.4	6.6	11.1	1.7	0.0	0.0	0.0	0.0	-	132.8	18.4	6.6	11.1	1.7	650	0.204	66.6
1967	173.1	21.8	9.5	14.4	1.5	0.0	0.0	0.0	0.0	-	173.1	21.8	9.5	14.4	1.5	675	0.256	83.6
1968	165.2	21.2	10.7	13.8	1.5	0.0	0.0	0.0	0.0	-	165.2	21.2	10.7	13.8	1.5	-	-	-
1969	203.8	27.9	11.0	17.0	1.6	0.0	0.0	0.0	0.0	-	203.8	27.9	11.0	17.0	1.6	-	-	-
1970	236.3	27.9	14.1	19.7	1.4	0.0	0.0	0.0	0.0	-	236.3	27.9	14.1	19.7	1.4	-	-	-
1971	285.9	36.2	18.4	23.8	1.5	0.0	0.0	0.0	0.0	-	285.9	36.2	18.4	23.8	1.5	830	0.344	112.3
1972	345.3	33.8	21.5	28.8	1.2	0.0	0.0	0.0	0.0	-	345.3	33.8	21.5	28.8	1.2	950	0.363	118.5
1973	386.1	39.9	21.5	32.2	1.2	0.0	0.0	0.0	0.0	-	386.1	39.9	21.5	32.2	1.2	1150	0.336	109.4
1974	481.5	62.0	30.7	40.1	1.5	0.0	0.0	0.0	0.0	-	481.5	62.0	30.7	40.1	1.5	1445	0.333	108.6
1975	473.1	51.6	27.6	39.4	1.3	0.0	0.0	0.0	0.0	-	473.1	51.6	27.6	39.4	1.3	1500	0.315	102.8
1976	507.5	67.5	33.8	42.3	1.6	0.0	0.0	0.0	0.0	-	507.5	67.5	33.8	42.3	1.6	1600	0.317	103.4
1977	630.0	81.0	37.7	52.5	1.5	0.0	0.0	0.0	0.0	-	630.0	81.0	37.7	52.5	1.5	1745	0.361	117.7
1978	729.8	92.1	38.4	60.8	1.5	0.0	0.0	0.0	0.0	-	729.8	92.1	38.4	60.8	1.5	1910	0.382	124.5
1979	768.7	76.7	49.7	64.1	1.2	0.0	0.0	0.0	0.0	-	768.7	76.7	49.7	64.1	1.2	2050	0.375	122.2
1980	1048.9	155.3	54.8	87.4	1.8	0.0	0.0	0.0	0.0	-	1048.9	155.3	54.6	87.4	1.8	2210	0.475	154.7
1981	1046.1	138.1	67.5	87.2	1.6	0.0	0.0	0.0	0.0	-	1046.1	138.1	67.5	87.2	1.6	2365	0.442	144.2
1982	1087.4	163.9	52.8	90.6	1.8	0.0	0.0	0.0	0.0	-	1087.4	163.9	52.8	90.6	1.8	2431	0.447	145.8
1983	1193.5	141.2	65.4	99.5	1.4	0.0	0.0	0.0	0.0	-	1193.5	141.2	65.4	99.5	1.4	2500	0.477	155.6
1983	1343.5	146.4	69.7	112.0	1.3	166.4	41.4	0.0	13.9	3.0	1509.9	173.1	87.8	125.8	1.4	2890	0.522	170.3
1985	1113.5	140.9	66.0	92.8	1.5	364.0	46.3	19.3	30.3	1.5	1477.5	172.5	88.7	123.1	1.4	3140	0.471	153.3
1986	1308.0	178.9	70.6	109.0	1.6	453.2	58.9	25.2	37.8	1.6	1761.2	221.9	95.8	146.8	1.5	3480	0.506	164.9
1987	1470.2	360.6	41.7	122.5	2.9	462.1	51.6	2.9	38.5	1.3	1932.3	405.4	61.5	161.0	2.5	3518	0.549	179.0
1988	1459.0	152.8	78.9	121.6	1.3	596.9	164.5	28.8	49.7	3.3	1817.9	210.5	55.5	151.5	1.4	3563	0.510	166.3

Figure 2-2  
Green Valley WSC Historical Water Use and Source

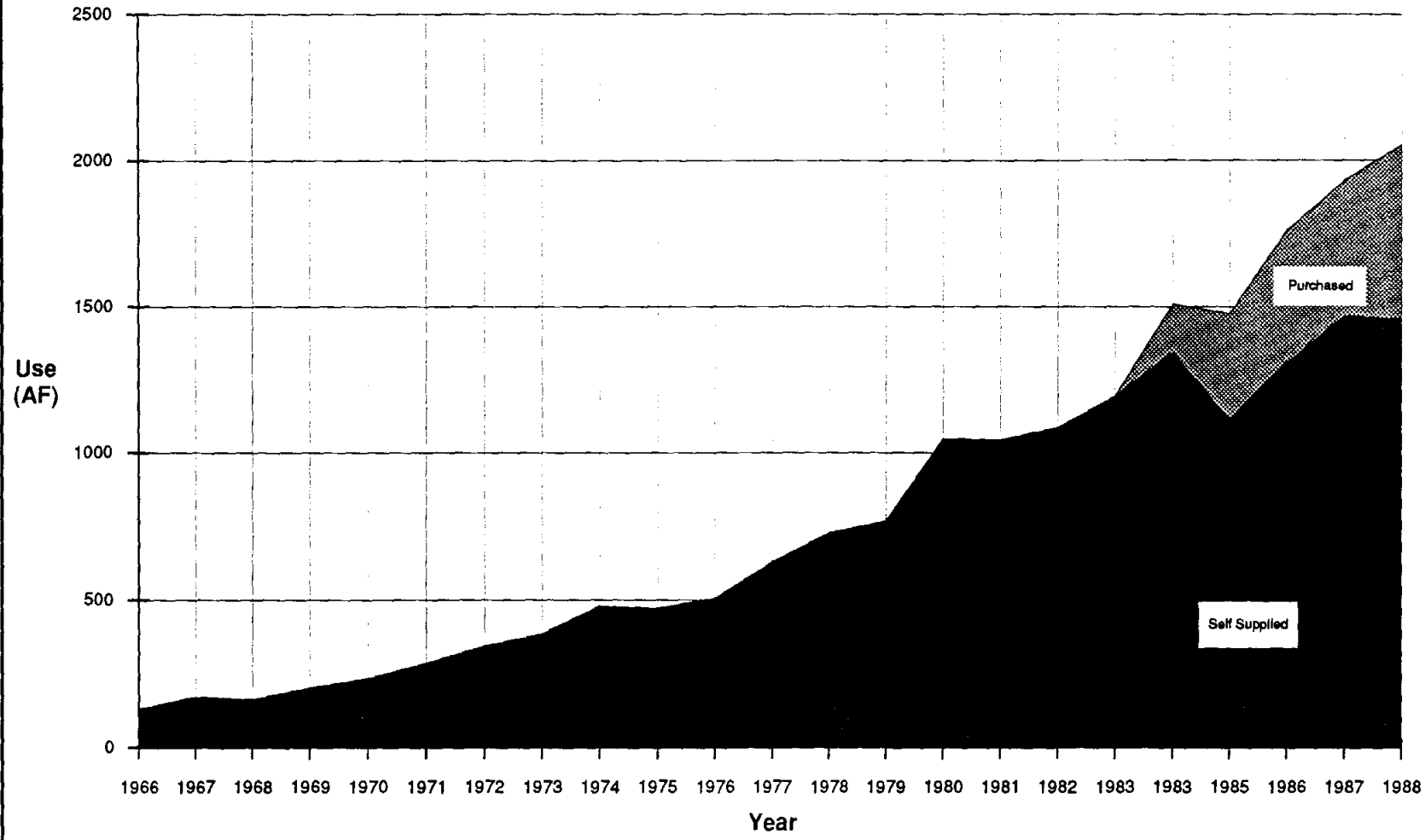



contributed to the rapid rate of Green Valley Growth. In 1983 the GVWSC began purchasing water from the City of New Braunfels to augment their groundwater supplies; a trend which continues to accelerate with a nearly three-fold increase in water use in the last ten years. The GVWSC water use rates continue to rise through 1988 and show no signs of the growth slow-down experienced in other areas in recent years.

Table 2-3 and Figure 2-3 show a much slower rate of growth for the Springs Hill WSC (SHWSC). Totally surrounding Seguin, the SHWSC has exhibited steady growth through the last decade but shows a slight acceleration since 1983. While Springs Hill is the only CRWA member totally dependent on surface water, it treats raw water purchased from the Guadalupe-Blanco River Authority and buys supplemental treated water from the Cities of New Braunfels and Seguin

The Crystal Clear WSC (CCWSC) has also shown a doubling in water use and number of connections in the last ten years (Table 2-4 and Figure 2-4). A large portion of that increase occurred between 1983 and 1985, probably as a spin-off of the phenomenal growth experienced in the Austin area during the same period. In recent years, however, the rate of growth in the CCWSC service area has slowed dramatically. Nearly all its water is provided from wells with occasional small purchases from the City of San Marcos.

Table 2-5 and Figure 2-5 show that East Central WSC (ECWSC) has experienced a similarly high rate of growth as the GVWSC. However, in recent years the rate of growth has diminished. All of East Central's supplies are currently purchased from San Antonio.

## **2.3 Existing Treatment Capacities and Infrastructure**

### **2.3.1 General Description**

The four water supply corporations which comprise the CRWA currently provide service to an estimated 36,500 persons within an area of approximately 618 square miles. Figure 2-6 provides an overview of the service area boundaries for the individual corporations along with the location of major production, treatment, and storage facilities, high service booster stations, and major transmission and distribution lines. The CRWA provides service primarily to rural Guadalupe County; however, service is also provided to portions of Bexar, Comal, Hays, and Wilson Counties. Green Valley and Crystal Clear water supply corporations utilize groundwater sources and interconnects with local municipal suppliers to provide service to their respective service areas. Springs Hill Water Supply Corporation obtains the majority of its supply through a surface water source on the Guadalupe River. The balance of the Springs Hill supply requirement is provided through an interconnect with the City of New Braunfels. East Central Water Supply Corporation obtains all of its supply from the San Antonio City Water Board via two interconnects.

Table 2-3  
Springs Hill Water Supply Corporation Historical Use

Year	January			February			March			April			May			June		
	Self. a/	Purch. b/	Total	Self. a/	Purch. b/	Total	Self. a/	Purch. b/	Total	Self. a/	Purch. b/	Total	Self. a/	Purch. b/	Total	Self. a/	Purch. b/	Total
1978	0.0	44.8	44.8	0.0	56.3	56.3	0.0	44.9	44.9	0.0	44.9	44.9	0.0	37.7	37.7	0.0	44.0	44.0
1979	0.0	61.5	61.5	0.0	48.9	48.9	0.0	48.9	48.9	0.0	41.9	41.9	0.0	55.3	55.3	0.0	54.7	54.7
1980	0.0	45.4	45.4	0.0	39.7	39.7	0.0	48.0	48.0	0.0	52.3	52.3	0.0	51.3	51.3	0.0	57.6	57.6
1981	0.0	45.5	45.5	0.0	39.5	39.5	0.0	51.6	51.6	0.0	62.8	62.8	0.0	61.9	61.9	0.0	64.6	64.6
1982	0.0	57.1	57.1	0.0	39.0	39.0	0.0	55.4	55.4	0.0	69.7	69.7	0.0	67.8	67.8	0.0	77.4	77.4
1983	0.0	43.4	43.4	0.0	40.2	40.2	0.0	74.0	74.0	0.0	69.8	69.8	0.0	78.6	78.6	0.0	73.7	73.7
1984	0.0	86.3	86.3	0.0	70.7	70.7	0.0	81.6	81.6	0.0	89.6	89.6	0.0	96.8	96.8	0.0	108.6	108.6
1985	0.0	32.1	32.1	0.0	52.6	52.6	0.0	47.3	47.3	0.0	41.2	41.2	0.0	51.1	51.1	0.0	51.7	51.7
1986	0.0	104.3	104.3	0.0	85.1	85.1	0.0	86.3	86.3	0.0	105.5	105.5	0.0	107.6	107.6	0.0	105.6	105.6
1987	0.0	94.8	94.8	0.0	79.1	79.1	0.0	84.7	84.7	0.0	101.5	101.5	0.0	131.5	131.5	0.0	96.7	96.7
1988	0.0	103.1	103.1	0.0	92.2	92.2	0.0	99.2	99.2	0.0	103.5	103.5	0.0	122.5	122.5	0.0	143.4	143.4

Year	July			August			September			October			November			December		
	Self. a/	Purch. b/	Total	Self. a/	Purch. b/	Total	Self. a/	Purch. b/	Total	Self. a/	Purch. b/	Total	Self. a/	Purch. b/	Total	Self. a/	Purch. b/	Total
1978	0.0	67.3	67.3	0.0	40.6	40.6	0.0	64.4	64.4	0.0	60.0	60.0	0.0	34.4	34.4	0.0	31.0	31.0
1979	0.0	67.4	67.4	0.0	65.3	65.3	0.0	49.9	49.9	0.0	61.9	61.9	0.0	49.6	49.6	0.0	41.1	41.1
1980	0.0	81.1	81.1	0.0	41.9	41.9	0.0	58.0	58.0	0.0	54.3	54.3	0.0	55.9	55.9	0.0	50.1	50.1
1981	0.0	74.6	74.6	0.0	86.1	86.1	0.0	58.1	58.1	0.0	79.3	79.3	0.0	80.1	80.1	0.0	61.9	61.9
1982	0.0	99.6	99.6	0.0	113.0	113.0	0.0	91.1	91.1	0.0	80.4	80.4	0.0	53.5	53.5	0.0	55.6	55.6
1983	0.0	97.0	97.0	0.0	90.6	90.6	0.0	93.0	93.0	0.0	66.3	66.3	0.0	65.1	65.1	0.0	95.8	95.8
1984	0.0	103.4	103.4	0.0	115.1	115.1	0.0	99.6	99.6	0.0	97.7	97.7	0.0	79.3	79.3	0.0	69.6	69.6
1985	0.0	49.8	49.8	0.0	76.4	76.4	0.0	44.4	44.4	0.0	44.0	44.0	0.0	54.8	54.8	0.0	49.5	49.5
1986	0.0	142.7	142.7	0.0	117.7	117.7	0.0	113.9	113.9	0.0	110.1	110.1	0.0	100.1	100.1	0.0	98.3	98.3
1987	0.0	72.6	72.6	0.0	117.3	117.3	0.0	67.2	67.2	0.0	74.7	74.7	0.0	54.3	54.3	0.0	68.0	68.0
1988	0.0	156.0	156.0	0.0	163.4	163.4	0.0	149.5	149.5	0.0	124.4	124.4	0.0	112.4	112.4	0.0	115.3	115.3

a/ Self-Supplied Ground & Surface.  
b/ Purchased from City of New Braunsfels, City of Seguin & GBRA.

Year	Self-Supplied					Purchased					Total Used					No. Taps	Annual Use	
	Total AF	Max. AF	Min. AF	Avg. AF	Max/Avg.	Total AF	Max. AF	Min. AF	Avg. AF	Max/Avg.	Total AF	Max. AF	Min. AF	Avg. AF	Max/Avg.		AF/Tap	gal./Tap
	1978	0.0	0.0	0.0	0.0	-	570.3	67.3	31.0	47.5	1.4	570.3	67.3	31.0	47.5		1.4	1428
1979	0.0	0.0	0.0	0.0	-	646.4	67.4	41.1	53.9	1.3	646.4	67.4	41.1	53.9	1.3	1583	0.408	133.1
1980	0.0	0.0	0.0	0.0	-	635.6	81.1	39.7	53.0	1.5	635.6	81.1	39.7	53.0	1.5	1683	0.378	123.1
1981	0.0	0.0	0.0	0.0	-	766.0	86.1	39.5	63.8	1.3	766.0	86.1	39.5	63.8	1.3	1798	0.426	138.8
1982	0.0	0.0	0.0	0.0	-	859.6	113.0	39.0	71.6	1.6	859.6	113.0	39.0	71.6	1.6	1893	0.454	148.0
1983	0.0	0.0	0.0	0.0	-	887.5	97.0	40.2	74.0	1.3	887.5	97.0	40.2	74.0	1.3	2012	0.441	143.8
1983	0.0	0.0	0.0	0.0	-	1098.3	115.1	69.6	91.5	1.3	1098.3	115.1	69.6	91.5	1.3	2207	0.498	162.2
1985	0.0	0.0	0.0	0.0	-	594.9	76.4	32.1	49.6	1.5	594.9	76.4	32.1	49.6	1.5	2314	0.257	83.8
1986	0.0	0.0	0.0	0.0	-	1277.2	142.7	85.1	106.4	1.3	1277.2	142.7	85.1	106.4	1.3	2800	0.456	148.7
1987	0.0	0.0	0.0	0.0	-	1048.5	117.3	54.3	87.4	1.3	1048.5	117.3	54.3	87.4	1.3	2826	0.371	120.9
1988	0.0	0.0	0.0	0.0	-	1499.2	163.4	79.1	117.4	1.4	1499.2	163.4	79.1	117.4	1.4	2900	0.486	158.4

Figure 2-3  
Springs Hill Water Supply Corporation  
Historical Water Use

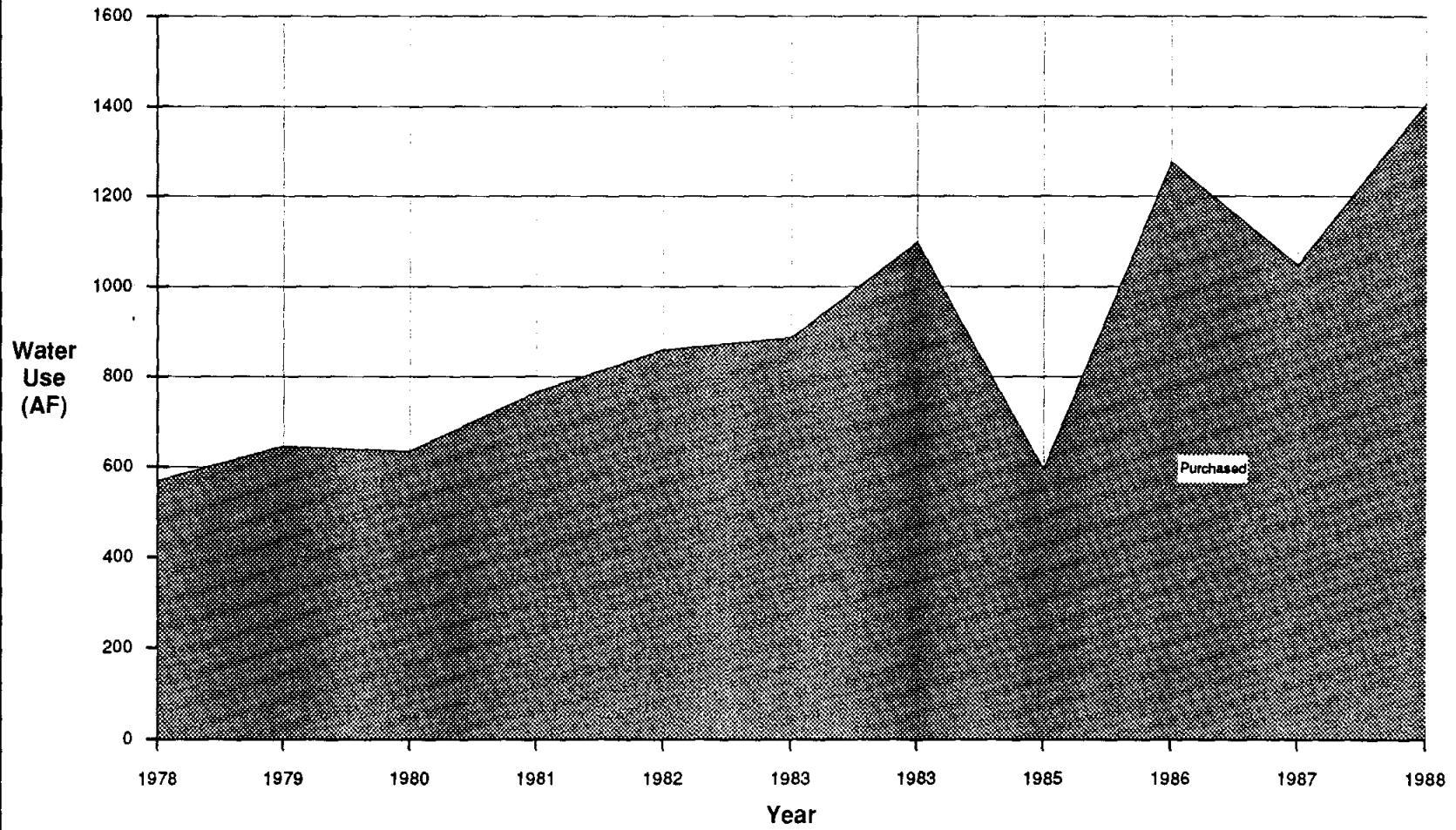

Table 5-16  
Proposed Lift Stations  
Sub-Area E Colonias

Lift Station Designation	Flow Rate (gpm)	Estimated Brake Horsepower	Estimated Cost (\$) a/
LS-1E	480	5.00	\$150,000
LS-2E	200	3.50	\$126,000
LS-3E	195	3.00	\$114,000
LS-4E	120	1.50	\$72,000
LS-7E	85	1.50	\$82,500
LS-8E	78	6.50	\$162,500
LS-11E	80	2.50	\$100,000

a/ From Figure 5-22

**Table 5-17**  
**Estimated Cost of Wastewater Treatment Plants**  
**Cameron County Sub-Area E Colonias**

Function	Treatment Plants			
	STP-1E	STP-2E	STP-3E	STP-7E
1. Construction Cost a/	\$414,207	\$519,984	\$178,227	\$58,167
2. Engineering b/	\$20,710	\$25,999	\$8,911	\$2,908
3. Land Acquisition c/	\$20,000	\$20,000	\$20,000	\$20,000
4. Surveying/staking d/	\$12,426	\$15,600	\$5,347	\$1,745
5. Legal and Administrative fees e/	\$10,355	\$13,000	\$4,456	\$1,454
6. Permitting and fees f/	\$8,284	\$10,400	\$3,565	\$1,163
7. Contingencies g/	\$62,131	\$77,998	\$26,734	\$8,725
<b>TOTAL</b>	<b>\$548,114</b>	<b>\$682,980</b>	<b>\$247,239</b>	<b>\$94,163</b>

- a/ All costs assume 1990 dollars (0% inflation)
- b/ Based on 5% of construction cost
- c/ Based on current estimated cost of \$5,000/acre
- d/ Based on 3% of construction cost
- e/ Based on 2.5% of construction cost
- f/ Based on 2% of construction cost
- g/ Based on 15% of construction cost

**Table 5-18**  
**Cost Comparison for Sewered System vs On-Site Wastewater Disposal**  
 Cameron County Sub-Area E Colonias *(Eastern America Colonias)*

Colonia Identification Number	2020 Population	2020 Units	2020 Unit Density (Units/Acre)	2020 Discharge (GPD)	WWTP Cost a/ (\$)	Sewer Cost b/ (\$)	Total Sewered Cost c/ (\$)	On-Site Cost d/ (\$)
A	B	C	D	E	F	G	H	I
1E,4E,8E,12E,13E	1,648	336	1.56	164,800	\$454,948	\$1,580,332	\$2,035,280	\$1,680,000
2E	680	139	2.78	68,000	\$199,469	\$566,019	\$765,488	\$695,000
3E	662	135	2.29	66,200	\$194,718	\$585,266	\$779,984	\$675,000
5E,10E	268	158	0.59	26,800	\$90,732	\$2,073,556	\$2,164,288	\$790,000
6E	211	95	0.45	21,100	\$75,688	\$750,817	\$826,505	\$475,000
7E	281	57	3.56	28,100	\$94,163	\$261,333	\$355,496	\$285,000
9E	218	45	1.41	21,800	\$77,536	\$265,995	\$343,531	\$225,000
11E	261	53	2.41	26,100	To Los Fresnos	\$439,666	\$439,666	\$265,000

*5,090,000*

- a/ Includes construction cost, engineering, land acquisition, administrative fees, permitting fees, and contingencies.
- b/ Cost based on preliminary design schematics. See pertinent section of report for detailed schematics and associated costs.
- c/ F+G
- d/ Based on mounded pressure-dose system at \$5,000/unit

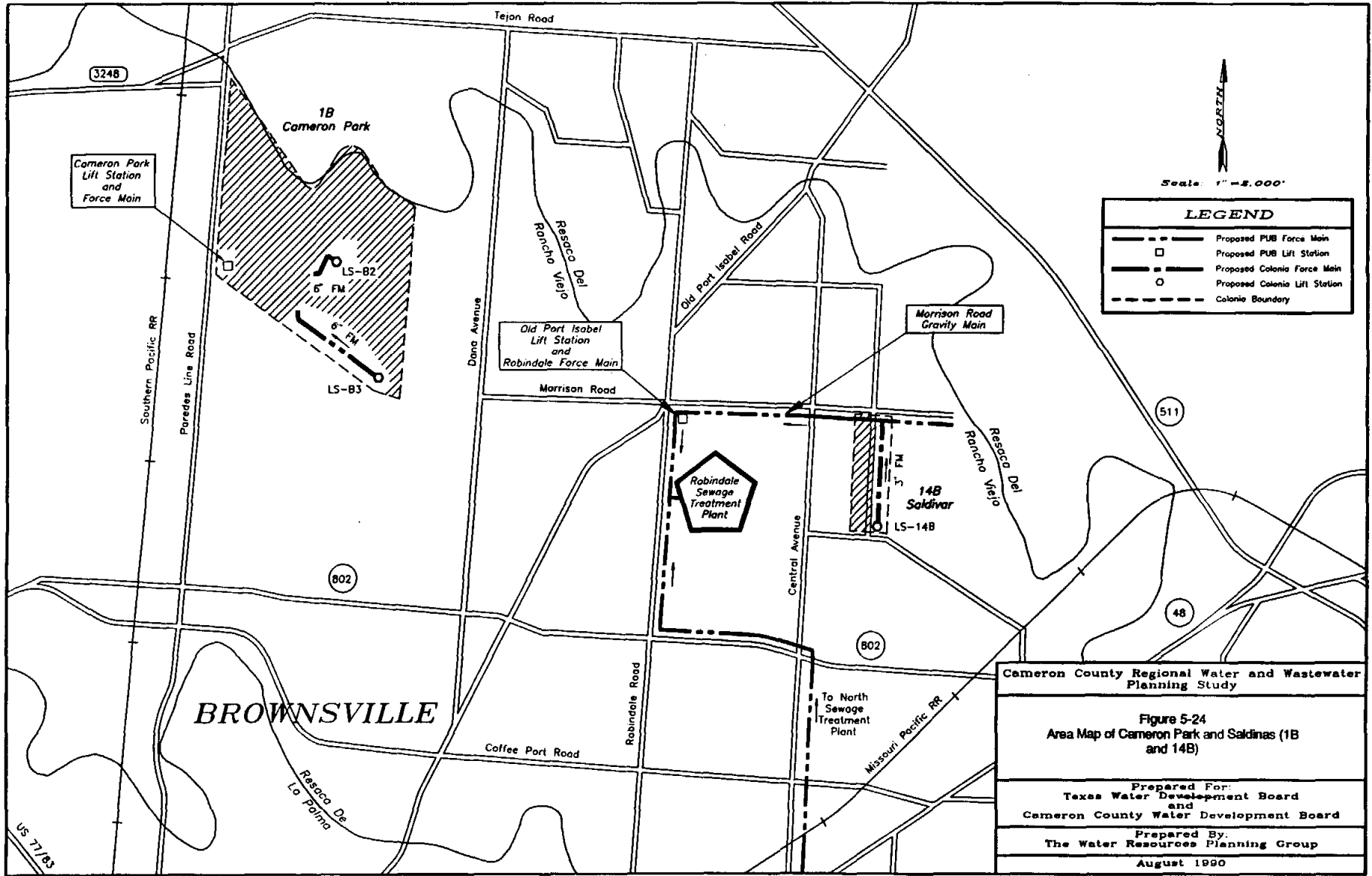

Cameron County Regional Water and Wastewater Planning Study

Figure 5-24  
Area Map of Cameron Park and Saldinas (1B and 14B)

Prepared For:  
Texas Water Development Board  
and  
Cameron County Water Development Board

Prepared By:  
The Water Resources Planning Group  
August 1990

Cameron County Regional Water and Wastewater Planning Study

Figure 5-25  
Site Map for Cameron Park (1B)

Prepared For:  
Texas Water Development Board  
and Cameron County Water Development Board

Prepared By:  
The Water Resources Planning Group  
August 1990

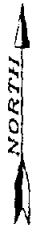
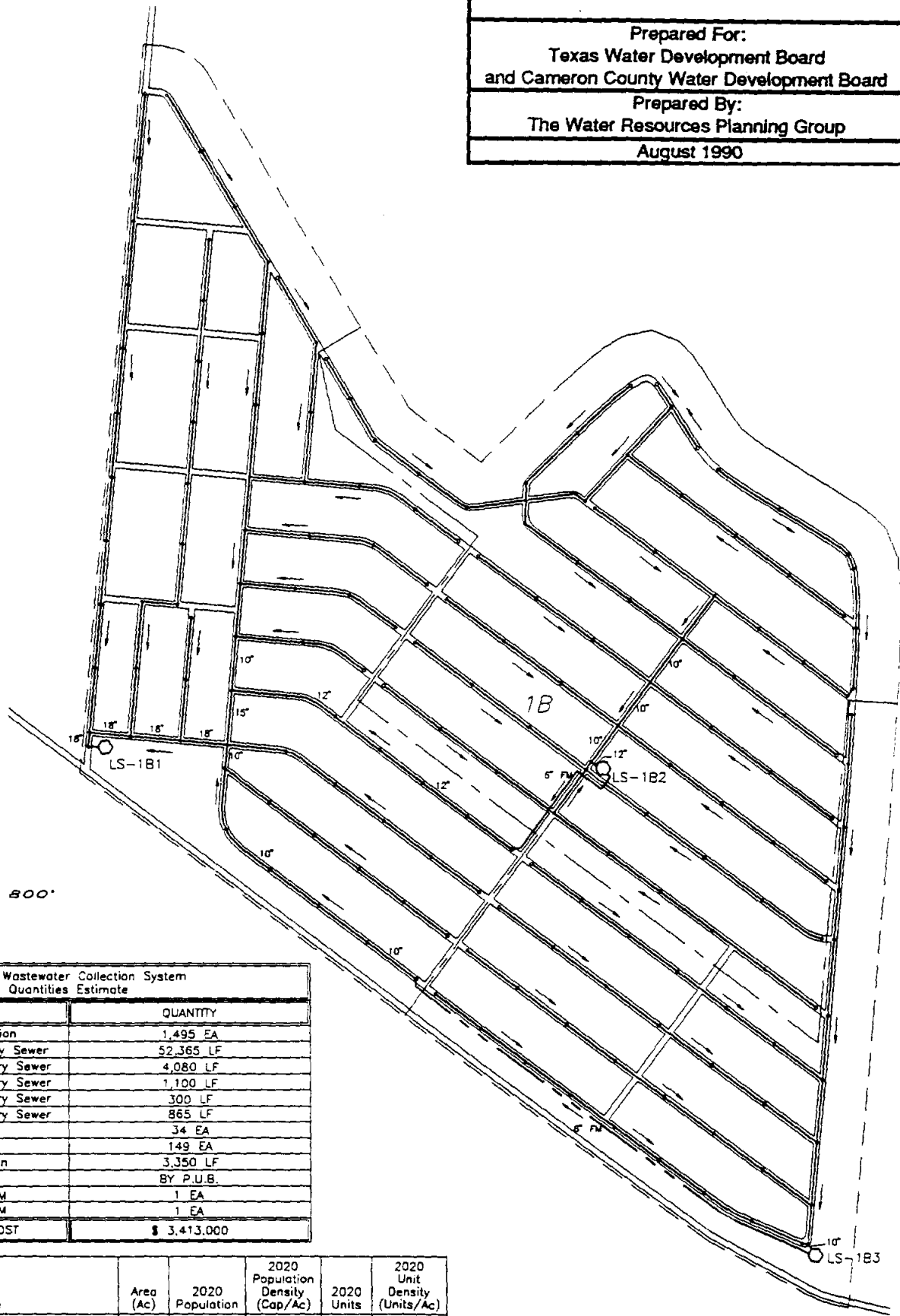

Scale: 1" = 800'

Internal Wastewater Collection System Quantities Estimate	
ITEM	QUANTITY
6" Service Connection	1,495 EA
8" SDR-35 PVC Sanitary Sewer	52,365 LF
10" SDR-35 PVC Sanitary Sewer	4,080 LF
12" SDR-35 PVC Sanitary Sewer	1,100 LF
15" SDR-35 PVC Sanitary Sewer	300 LF
18" SDR-35 PVC Sanitary Sewer	865 LF
Clean Out	34 EA
Manhole	149 EA
6" PVC Force Main	3,350 LF
LS-1B1	BY P.U.B.
LS-1B2 590 GPM	1 EA
LS-1B3 370 GPM	1 EA
<b>TOTAL ESTIMATED COST</b>	<b>\$ 3,413,000</b>

Colonia Designation	Colonia Name	Area (Ac)	2020 Population	2020 Population Density (Pop/Ac)	2020 Units	2020 Unit Density (Units/Ac)
1B	Cameron Park	360	7,327	20.35	1,495	4.15



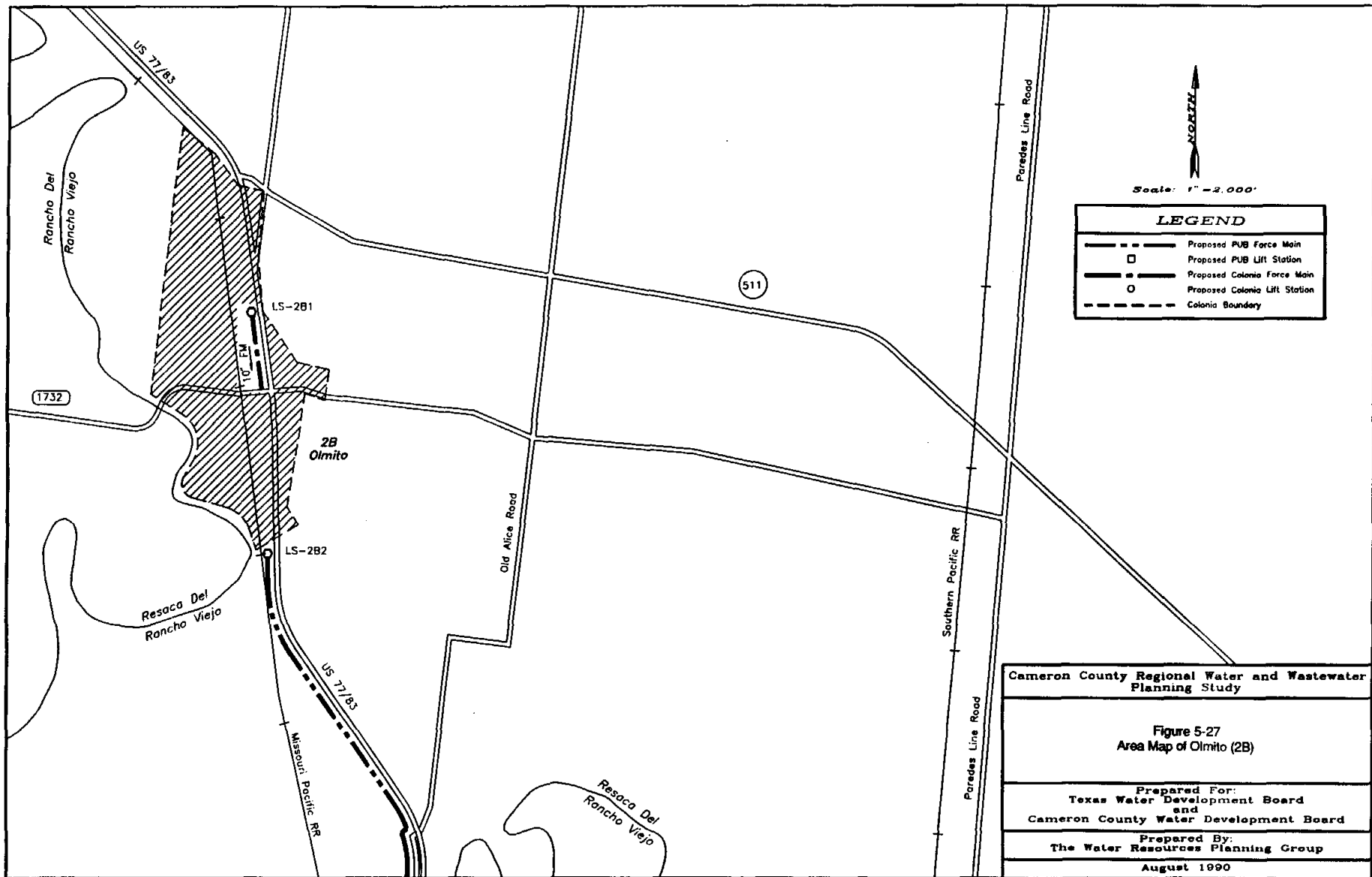

NORTH  
Scale: 1" = 1,000'

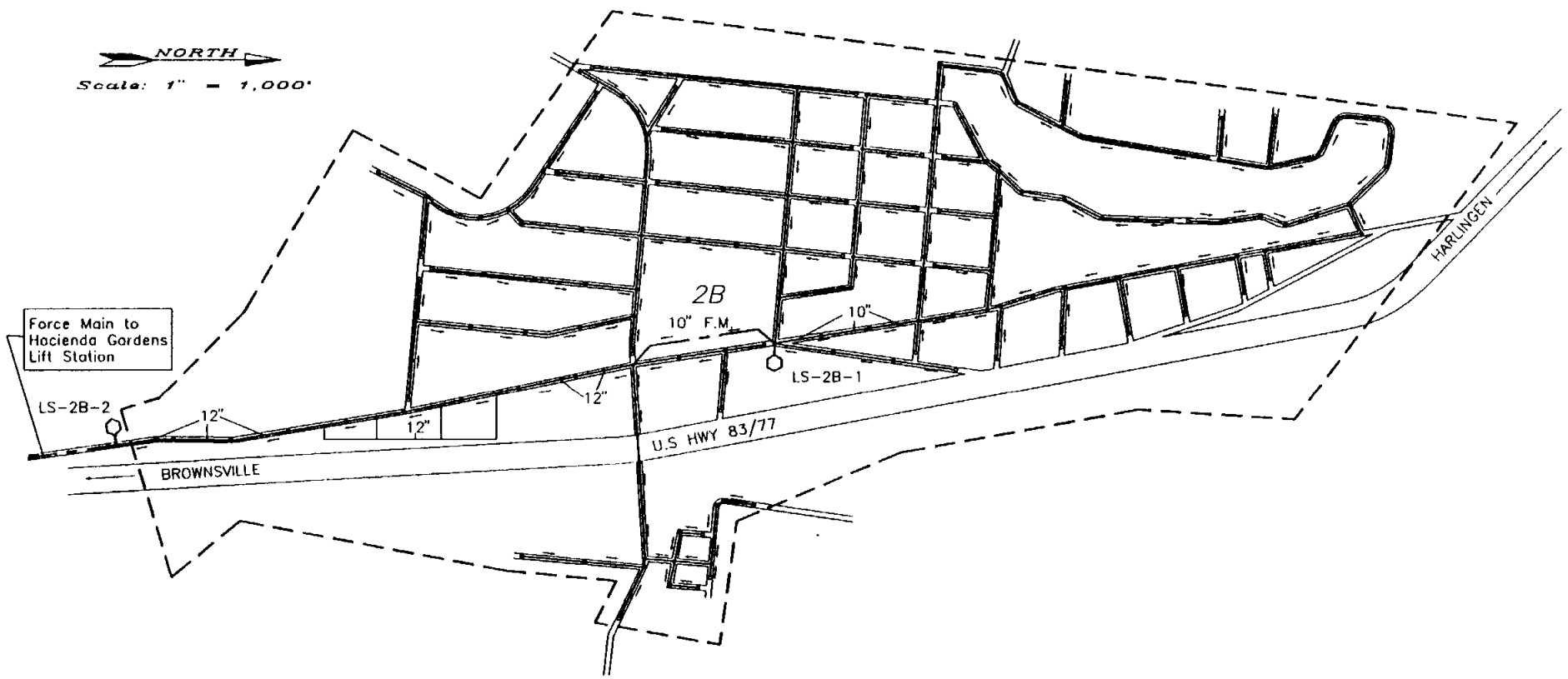

Colonia Designation	Colonia Name	Area (Ac)	2020 Population	2020 Population Density (Cap/Ac)	2020 Units	2020 Unit Density (Units/Ac)
2B	Olmito	387	6,532	9.13	721	1.86

Internal Wastewater Collection System Quantities Estimate	
ITEM	QUANTITY
6" Service Connection	721 EA
8" SDR-35 PVC Sanitary Sewer	42,910 LF
10" SDR-35 PVC Sanitary Sewer	900 LF
12" SDR-35 PVC Sanitary Sewer	2,850 LF
15" SDR-35 PVC Sanitary Sewer	N/A
18" SDR-35 PVC Sanitary Sewer	N/A
Clean Out	46 EA
Manhole	108 EA
4" PVC Force Main	N/A
6" PVC Force Main	N/A
8" PVC Force Main	N/A
10" PVC Force Main	10,900 LF
12" PVC Force Main	N/A
LS-2B1 830 GPM (8.0 HP)	1 EA
LS-2B2 900 GPM (12.5HP)	1 EA
<b>TOTAL ESTIMATED COST</b>	<b>\$ 2,877,866</b>

Cameron County Regional Water and Wastewater Planning Study

Figure 5-28  
Site Map of Olmito (2B)

Prepared For:  
Texas Water Development Board  
and Cameron County Water Development Board

Prepared By:  
The Water Resources Planning Group  
August 1990

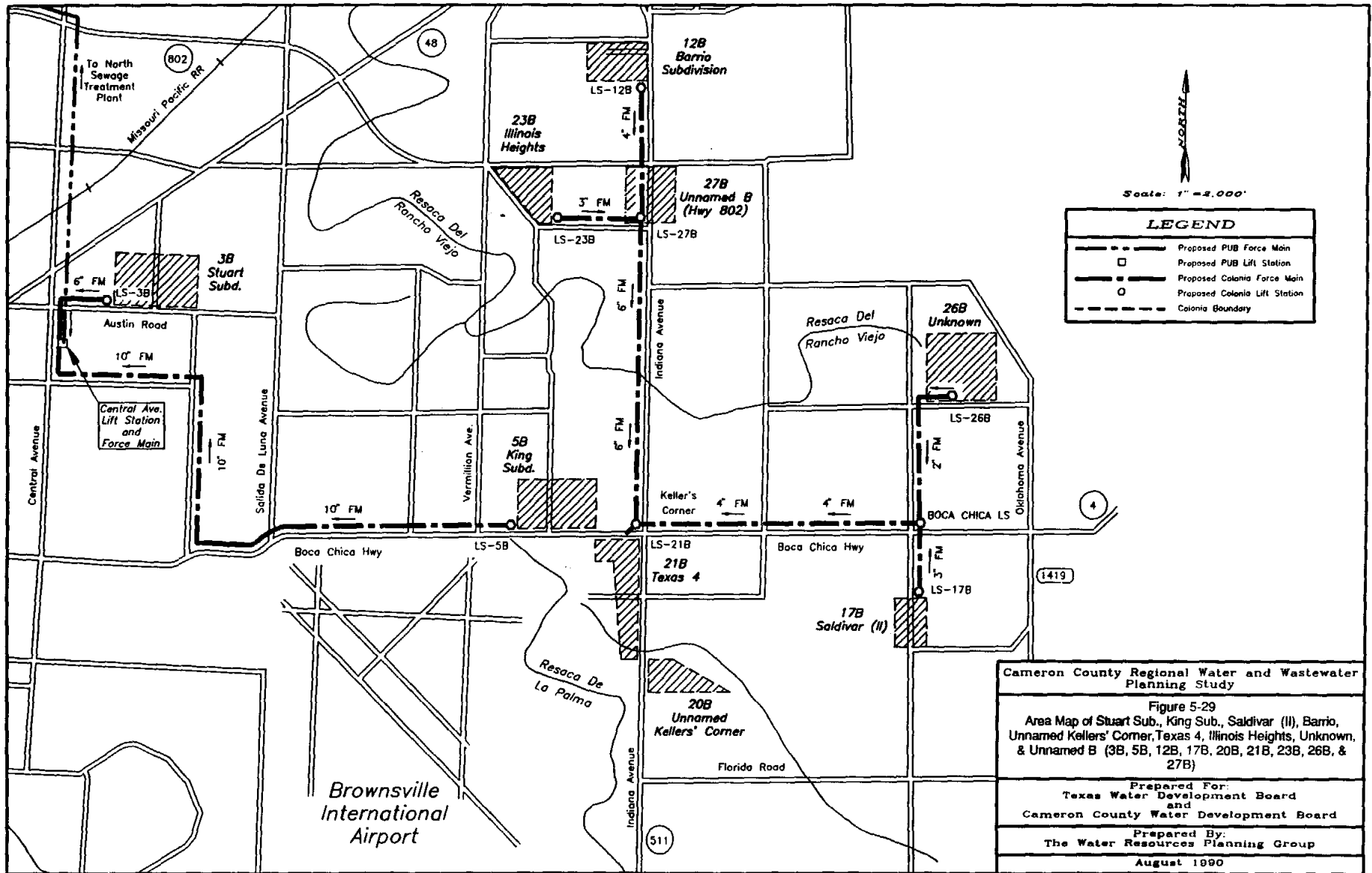

Scale: 1" = 2,000'

LEGEND	
	Proposed PUB Force Main
	Proposed PUB Lift Station
	Proposed Colonia Force Main
	Proposed Colonia Lift Station
	Colonia Boundary

Cameron County Regional Water and Wastewater Planning Study

Figure 5-29  
 Area Map of Stuart Sub., King Sub., Saldivar (II), Barrio, Unnamed Kellers' Corner, Texas 4, Illinois Heights, Unknown, & Unnamed B (3B, 5B, 12B, 17B, 20B, 21B, 23B, 26B, & 27B)

Prepared For:  
 Texas Water Development Board  
 and  
 Cameron County Water Development Board

Prepared By:  
 The Water Resources Planning Group  
 August 1990

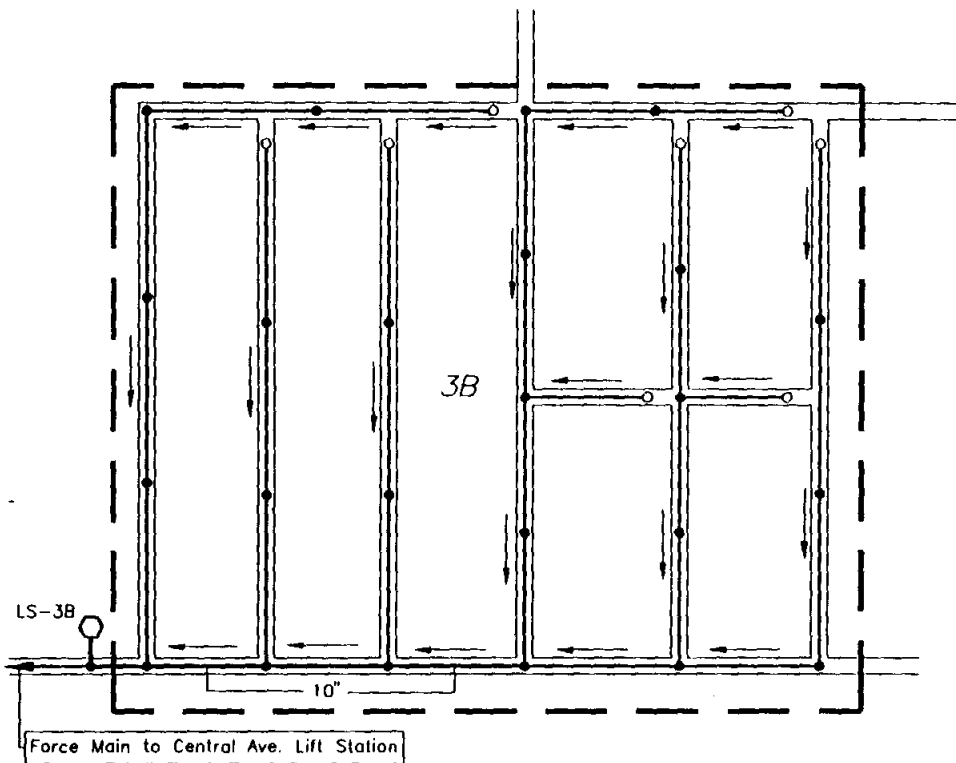

NORTH  
↑  
Scale: 1" = 400'

Colonia Designation	Colonia Name	Area (Ac)	2020 Population	2020 Population Density (Cap/Ac)	2020 Units	2020 Unit Density (Units/Ac)
3B	Stuart Subdivision	50	1,960	39.20	401	8.02

Internal Wastewater Collection System Quantities Estimate	
ITEM	QUANTITY
6" Service Connection	401 EA
8" SDR-35 PVC Sanitary Sewer	9,250 LF
10" SDR-35 PVC Sanitary Sewer	800 LF
12" SDR-35 PVC Sanitary Sewer	N/A
15" SDR-35 PVC Sanitary Sewer	N/A
18" SDR-35 PVC Sanitary Sewer	N/A
Clean Out	8 EA
Manhole	24 EA
4" PVC Force Main	N/A
6" PVC Force Main	N/A
8" PVC Force Main	2,000 LF
10" PVC Force Main	N/A
12" PVC Force Main	N/A
LS-3B 530 GPM (6 HP)	1 EA
<b>TOTAL ESTIMATED COST</b>	<b>\$ 831,300</b>

**Cameron County Regional Water and Wastewater Planning Study**

---

**Figure 5-30  
Site Map of Stuart Subdivision (3B)**

---

**Prepared For:  
Texas Water Development Board  
and Cameron County Water Development Board**

---

**Prepared By:  
The Water Resources Planning Group**

---

**August 1990**

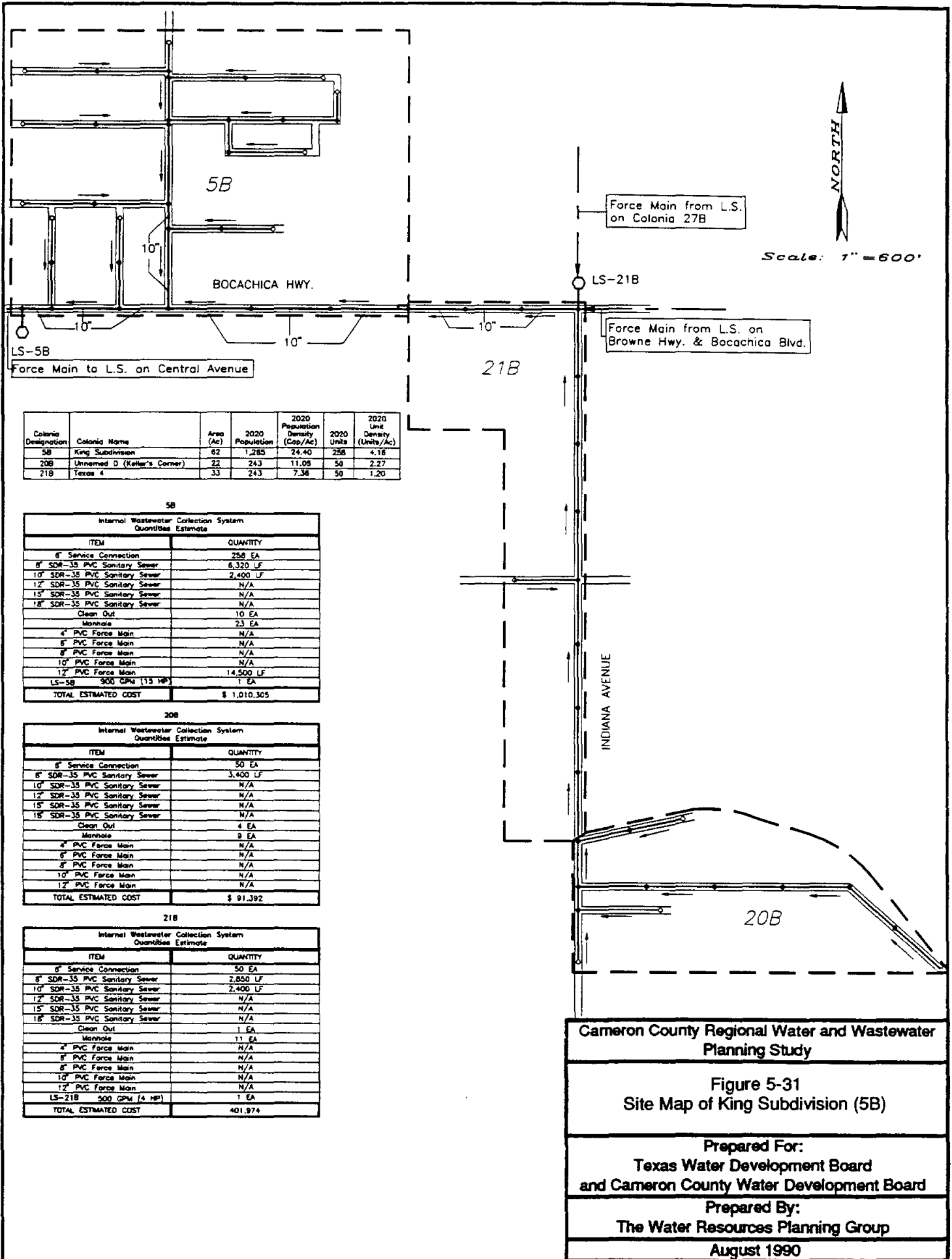

Colonia Designation	Colonia Name	Area (Ac)	2020 Population	2020 Population Density (Cps/Ac)	2020 Units	2020 Unit Density (Units/Ac)
5B	King Subdivision	62	1,285	24.40	258	4.16
20B	Unnamed D (Keller's Corner)	22	243	11.05	50	2.27
21B	Texas 4	33	243	7.36	50	1.20

5B

Internal Wastewater Collection System Quantities Estimate	
ITEM	QUANTITY
6" Service Connection	258 EA
8" SDR-35 PVC Sanitary Sewer	6,320 LF
10" SDR-35 PVC Sanitary Sewer	2,400 LF
12" SDR-35 PVC Sanitary Sewer	N/A
15" SDR-35 PVC Sanitary Sewer	N/A
18" SDR-35 PVC Sanitary Sewer	N/A
Clean Out	10 EA
Manhole	23 EA
4" PVC Force Main	N/A
6" PVC Force Main	N/A
8" PVC Force Main	N/A
10" PVC Force Main	N/A
12" PVC Force Main	14,500 LF
LS-5B 300 GPM (15 HP)	1 EA
<b>TOTAL ESTIMATED COST</b>	<b>\$ 1,010,305</b>

20B

Internal Wastewater Collection System Quantities Estimate	
ITEM	QUANTITY
6" Service Connection	50 EA
8" SDR-35 PVC Sanitary Sewer	3,400 LF
10" SDR-35 PVC Sanitary Sewer	N/A
12" SDR-35 PVC Sanitary Sewer	N/A
15" SDR-35 PVC Sanitary Sewer	N/A
18" SDR-35 PVC Sanitary Sewer	N/A
Clean Out	4 EA
Manhole	9 EA
4" PVC Force Main	N/A
6" PVC Force Main	N/A
8" PVC Force Main	N/A
10" PVC Force Main	N/A
12" PVC Force Main	N/A
<b>TOTAL ESTIMATED COST</b>	<b>\$ 91,392</b>

21B

Internal Wastewater Collection System Quantities Estimate	
ITEM	QUANTITY
6" Service Connection	50 EA
8" SDR-35 PVC Sanitary Sewer	2,850 LF
10" SDR-35 PVC Sanitary Sewer	2,400 LF
12" SDR-35 PVC Sanitary Sewer	N/A
15" SDR-35 PVC Sanitary Sewer	N/A
18" SDR-35 PVC Sanitary Sewer	N/A
Clean Out	1 EA
Manhole	11 EA
4" PVC Force Main	N/A
6" PVC Force Main	N/A
8" PVC Force Main	N/A
10" PVC Force Main	N/A
12" PVC Force Main	N/A
LS-21B 500 GPM (4 HP)	1 EA
<b>TOTAL ESTIMATED COST</b>	<b>401,974</b>

Cameron County Regional Water and Wastewater Planning Study

Figure 5-31  
Site Map of King Subdivision (5B)

Prepared For:  
Texas Water Development Board  
and Cameron County Water Development Board

Prepared By:  
The Water Resources Planning Group

August 1990

Colonia Designation	Colonia Name	Area (Ac)	2020 Population	2020 Population Density (Cap/Ac)	2020 Units	2020 Unit Density (Units/Ac)
12B	Barrio Subdivision	18	389	21.61	79	4.39

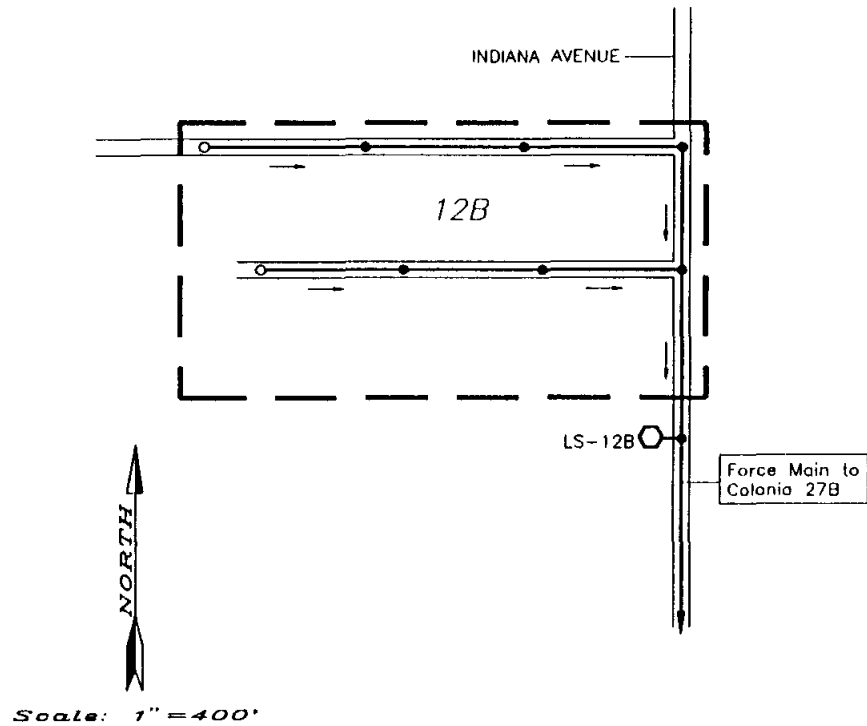

Internal Wastewater Collection System Quantities Estimate	
ITEM	QUANTITY
6" Service Connection	79 EA
8" SDR-35 PVC Sanitary Sewer	2,450 LF
10" SDR-35 PVC Sanitary Sewer	N/A
12" SDR-35 PVC Sanitary Sewer	N/A
15" SDR-35 PVC Sanitary Sewer	N/A
18" SDR-35 PVC Sanitary Sewer	N/A
Clean Out	2 EA
Manhole	7 EA
4" PVC Force Main	2,200 LF
6" PVC Force Main	N/A
8" PVC Force Main	N/A
10" PVC Force Main	N/A
12" PVC Force Main	N/A
LS-12B 120 GPM (2 HP)	1 EA
<b>TOTAL ESTIMATED COST</b>	<b>\$ 276,291</b>

Cameron County Regional Water and Wastewater  
Planning Study

Figure 5-32  
Site of Barrio Subdivision (12B)

Prepared For:  
Texas Water Development Board  
and Cameron County Water Development Board

Prepared By:  
The Water Resources Planning Group

August 1990

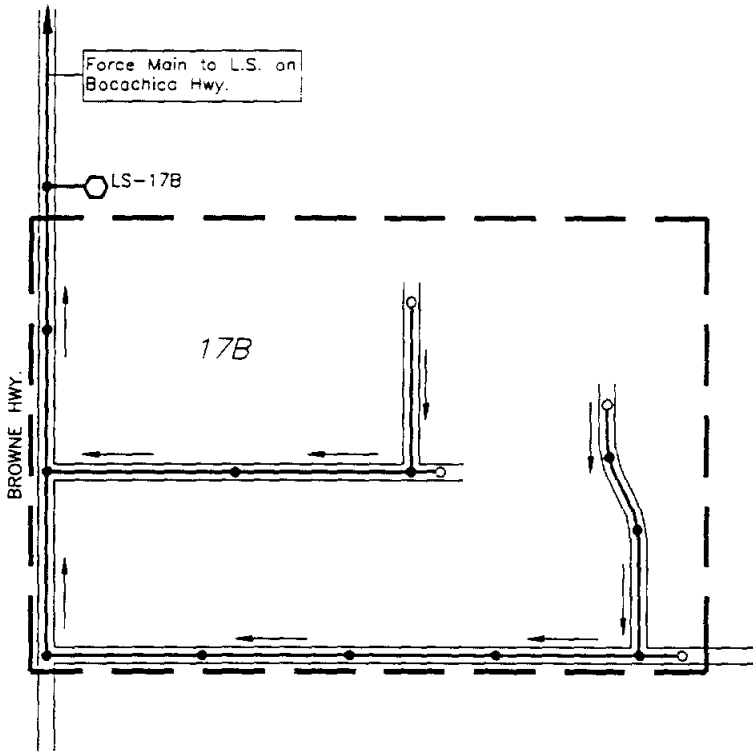

NORTH  
↑  
Scale: 1" = 400'

Colonia Designation	Colonia Name	Area (Ac)	2020 Population	2020 Population Density (Cap/Ac)	2020 Units	2020 Unit Density (Units/Ac)
17B	Saldivor (II)	33	272	8.24	56	1.70

Internal Wastewater Collection System Quantities Estimate	
ITEM	QUANTITY
6" Service Connection	56 EA
8" SDR-35 PVC Sanitary Sewer	3,980 LF
10" SDR-35 PVC Sanitary Sewer	N/A
12" SDR-35 PVC Sanitary Sewer	N/A
15" SDR-35 PVC Sanitary Sewer	N/A
18" SDR-35 PVC Sanitary Sewer	N/A
Clean Out	4 EA
Manhole	12 EA
3" PVC Force Main	1,500 LF
6" PVC Force Main	N/A
8" PVC Force Main	N/A
10" PVC Force Main	N/A
12" PVC Force Main	N/A
LS-17B 85 GPM (1.5 HP)	1 EA
<b>TOTAL ESTIMATED COST</b>	<b>\$ 282,672</b>

**Cameron County Regional Water and Wastewater  
Planning Study**

**Figure 5-33  
Site Map of Saldivor (II) (17B)**

**Prepared For:  
Texas Water Development Board  
and Cameron County Water Development Board**

**Prepared By:  
The Water Resources Planning Group**

**August 1990**

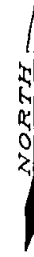
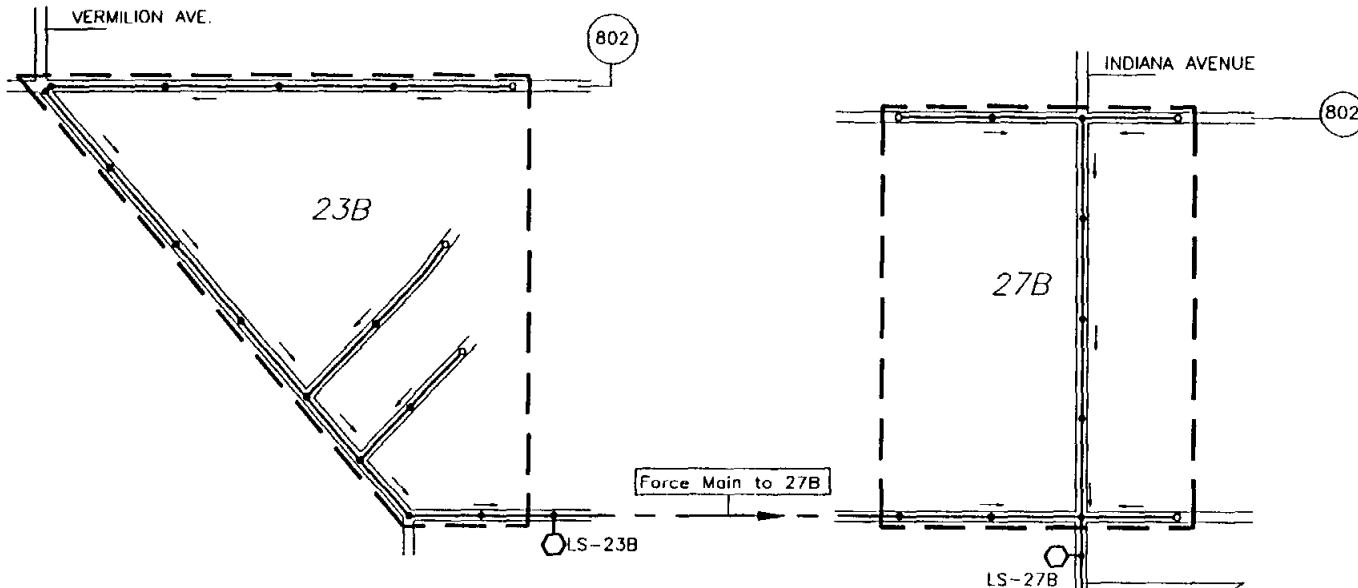

Scale: 1" = 600'

Colonia Designation	Colonia Name	Area (Ac)	2020 Population	2020 Population Density (Cap/Ac)	2020 Units	2020 Unit Density (Units/Ac)
23B	Illinois Heights	25	204	8.16	42	1.68
27B	Unnamed B (HWY 802)	22	97	4.41	20	0.91

Force Main to L.S. on Keller's Corner (21B); Intersection of Bacachica Hwy & Indiana Ave.

23B

Internal Wastewater Collection System Quantities Estimate	
ITEM	QUANTITY
6" Service Connection	42 EA
8" SDR-35 PVC Sanitary Sewer	4,800 LF
Clean Out	3 EA
Manhole	15 EA
3" PVC Force Main	1,500 LF
LS-23B 61 GPM (1 HP)	1 EA
<b>TOTAL ESTIMATED COST</b>	<b>\$ 271,212</b>

27B

Internal Wastewater Collection System Quantities Estimate	
ITEM	QUANTITY
6" Service Connection	20 EA
8" SDR-35 PVC Sanitary Sewer	3,050 LF
Clean Out	3 EA
Manhole	9 EA
6" PVC Force Main	7,000 LF
LS-27B 210 GPM (4 HP)	1 EA
<b>TOTAL ESTIMATED COST</b>	<b>\$ 402,841</b>

Cameron County Regional Water and Wastewater Planning Study

Figure 5-34  
Site Map of Illinois Heights and Unnamed B (23B and 27B)

Prepared For:  
Texas Water Development Board  
and Cameron County Water Development Board

Prepared By:  
The Water Resources Planning Group

August 1990



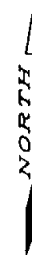
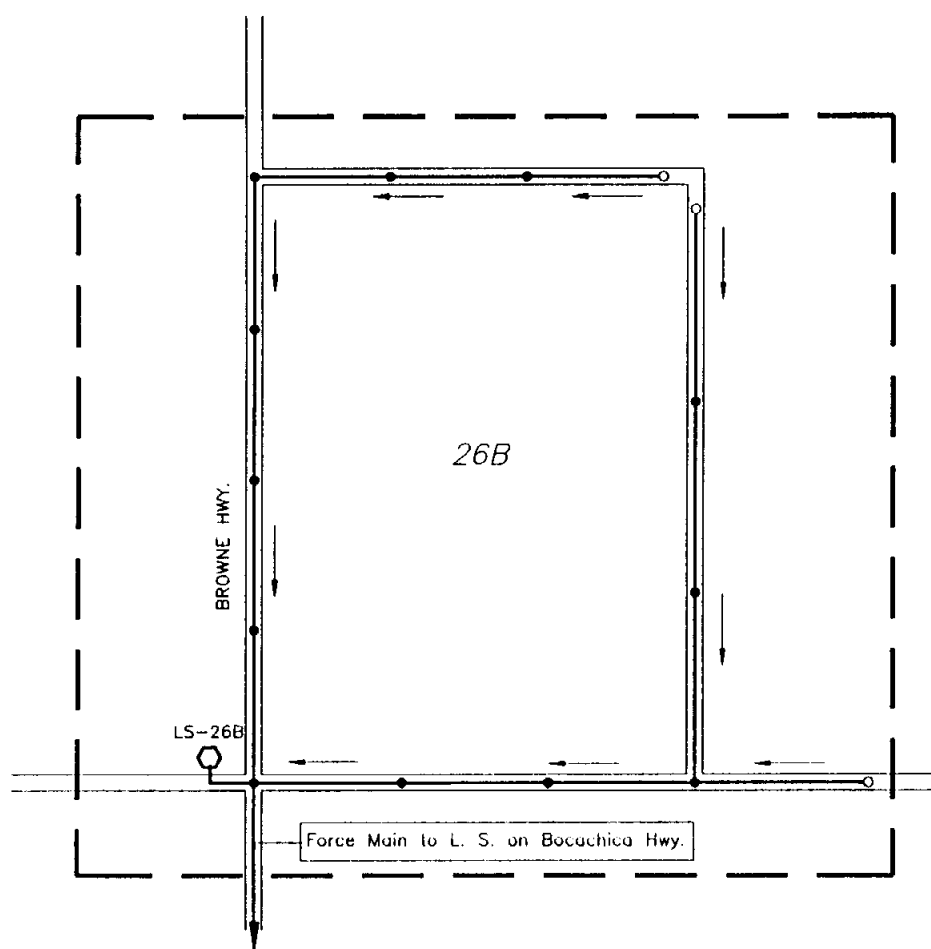

Scale: 1" = 400'

Colonia Designation	Colonia Name	Area (Ac)	2020 Population	2020 Population Density (Cap/Ac)	2020 Units	2020 Unit Density (Units/Ac)
26B	Unknown	38	117	3.08	24	0.63

Internal Wastewater Collection System Quantities Estimate	
ITEM	QUANTITY
6" Service Connection	24 EA
8" SDR-35 PVC Sanitary Sewer	4,730 LF
10" SDR-35 PVC Sanitary Sewer	N/A
12" SDR-35 PVC Sanitary Sewer	N/A
15" SDR-35 PVC Sanitary Sewer	N/A
18" SDR-35 PVC Sanitary Sewer	N/A
Clean Out	3 EA
Manhole	12 EA
2" PVC Force Main	3,500 LF
6" PVC Force Main	N/A
8" PVC Force Main	N/A
10" PVC Force Main	N/A
12" PVC Force Main	N/A
LS-26B 35 GPM (2 HP)	1 EA
<b>TOTAL ESTIMATED COST</b>	<b>\$ 316,660</b>

**Cameron County Regional Water and Wastewater Planning Study**

**Figure 5-35  
Site Map of Unknown (26B)**

**Prepared For:  
Texas Water Development Board  
and Cameron County Water Development Board**

**Prepared By:  
The Water Resources Planning Group**

**August 1990**

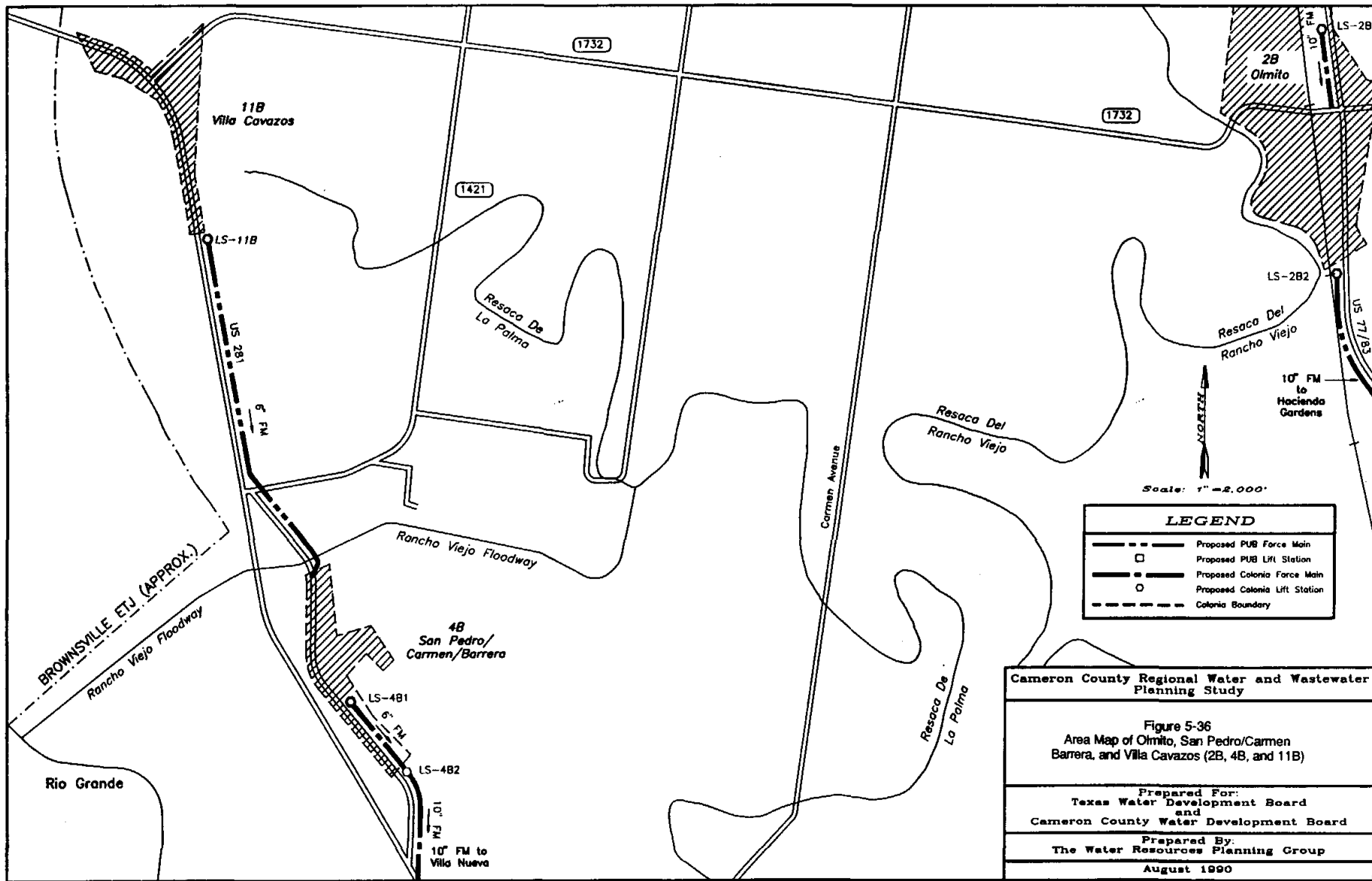

Colonia Designation	Colonia Name	Area (Ac)	2020 Population	2020 Population Density (Cap/Ac)	2020 Units	2020 Unit Density (Units/Ac)
4B	San Pedro/Carmen/Barrera Gd.	63	1,450	23.02	296	4.70

Internal Wastewater Collection System Quantities Estimate	
ITEM	QUANTITY
6" Service Connection	296 EA
8" SDR-35 PVC Sanitary Sewer	8,950 LF
10" SDR-35 PVC Sanitary Sewer	350 LF
12" SDR-35 PVC Sanitary Sewer	N/A
15" SDR-35 PVC Sanitary Sewer	N/A
18" SDR-35 PVC Sanitary Sewer	N/A
Clean Out	6 EA
Manhole	28 EA
4" PVC Force Main	100 LF
6" PVC Force Main	N/A
8" PVC Force Main	N/A
10" PVC Force Main	16,000 LF
12" PVC Force Main	N/A
LS-4B1 300 GPM (3.0HP)	1 EA
LS-4B2 520 GPM (8.5HP)	1 EA
<b>TOTAL ESTIMATED COST</b>	<b>\$ 1,112,964</b>

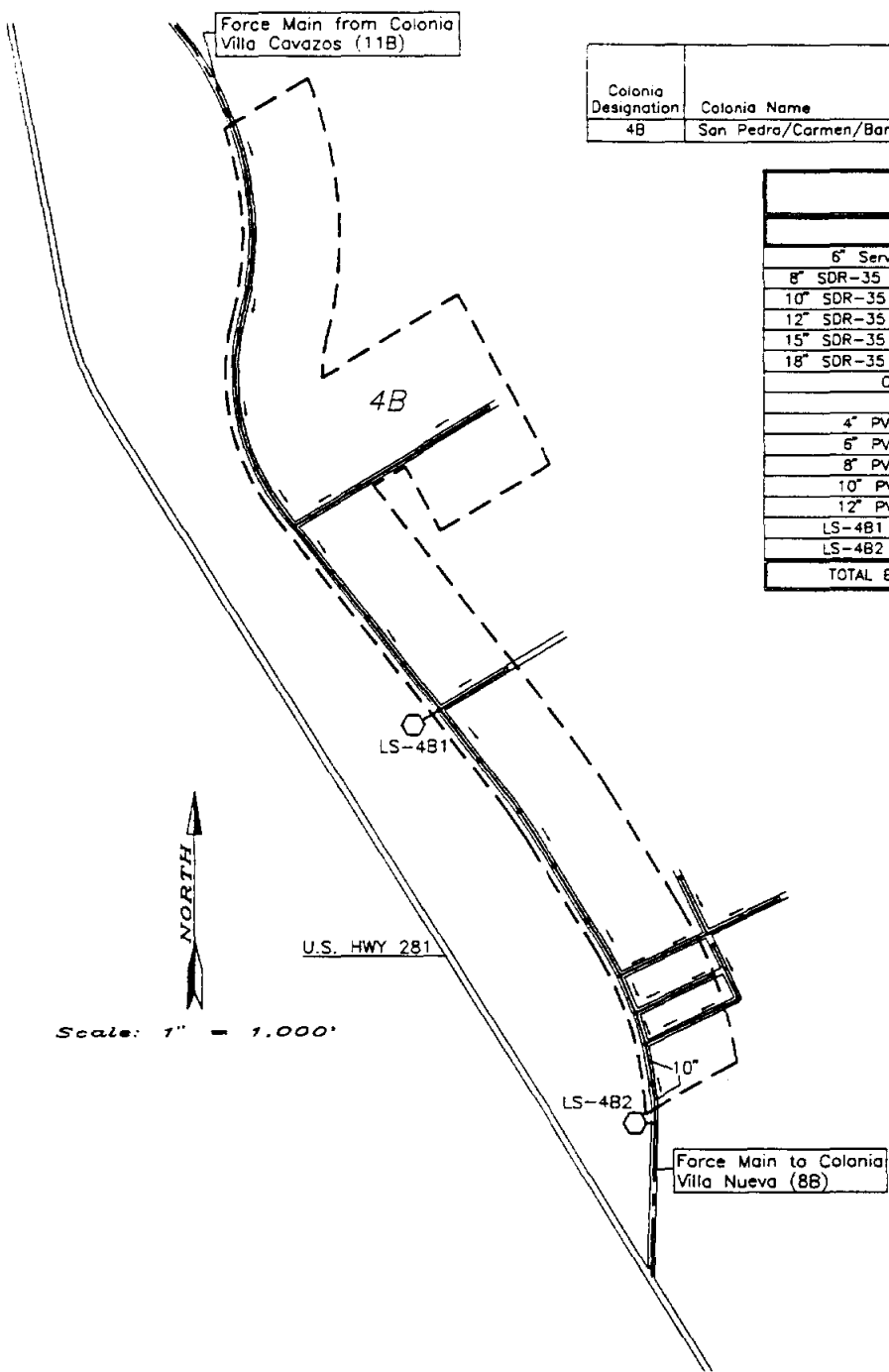

**Cameron County Regional Water and Wastewater Planning Study**  
**Figure 5-37**  
**Site Map of San Pedro/Carmen Barrera (4B)**  
 Prepared For:  
**Texas Water Development Board**  
**and Cameron County Water Development Board**  
 Prepared By:  
**The Water Resources Planning Group**  
**August 1990**

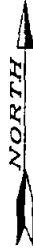

Scale: 1" = 600'

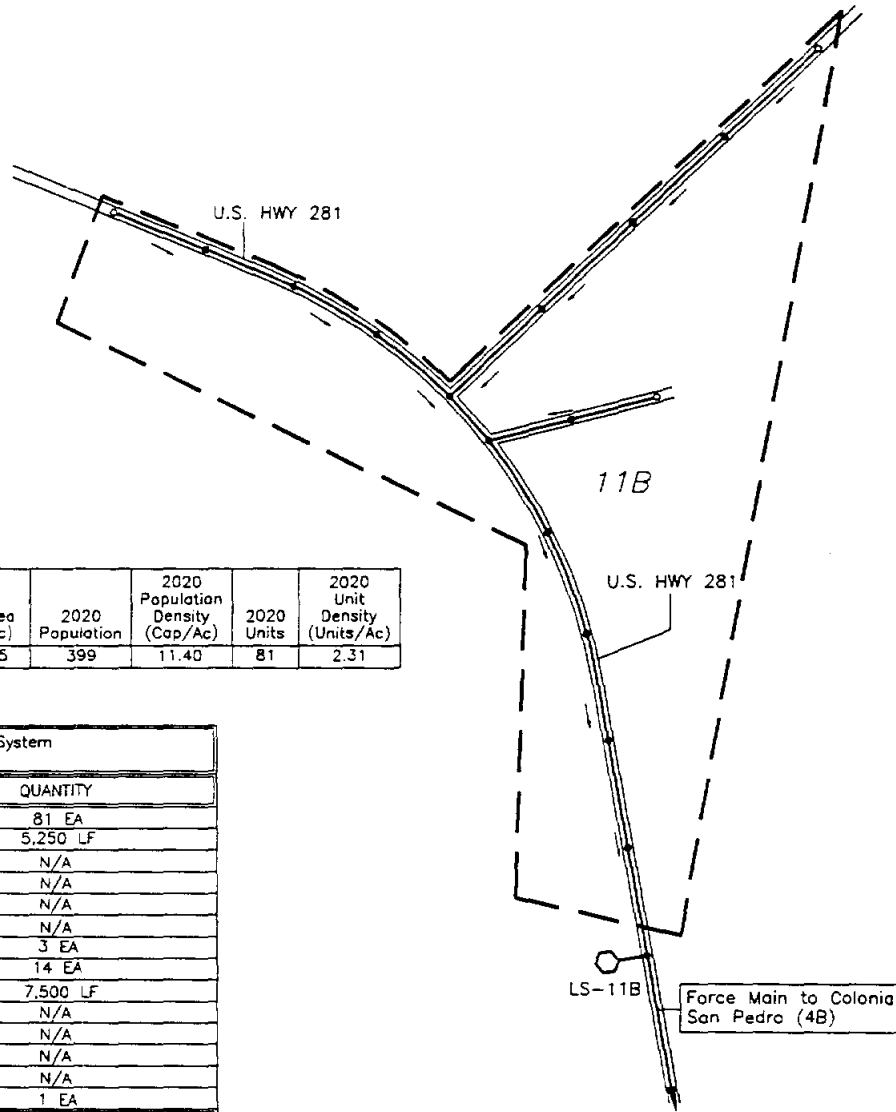

Colonia Designation	Colonia Name	Area (Ac)	2020 Population	2020 Population Density (Cap/Ac)	2020 Units	2020 Unit Density (Units/Ac)
11B	Villa Cavazos	35	399	11.40	81	2.31

Internal Wastewater Collection System Quantities Estimate	
ITEM	QUANTITY
6" Service Connection	81 EA
8" SDR-35 PVC Sanitary Sewer	5,250 LF
10" SDR-35 PVC Sanitary Sewer	N/A
12" SDR-35 PVC Sanitary Sewer	N/A
15" SDR-35 PVC Sanitary Sewer	N/A
18" SDR-35 PVC Sanitary Sewer	N/A
Clean Out	3 EA
Manhole	14 EA
4" PVC Force Main	7,500 LF
6" PVC Force Main	N/A
8" PVC Force Main	N/A
10" PVC Force Main	N/A
12" PVC Force Main	N/A
LS-11B 120 GPM (4 HP)	1 EA
<b>TOTAL ESTIMATED COST</b>	<b>\$ 490,423</b>

Cameron County Regional Water and Wastewater Planning Study

Figure 5-38  
Site Map of Villa Cavazos (11B)

Prepared For:  
Texas Water Development Board  
and Cameron County Water Development Board

Prepared By:  
The Water Resources Planning Group

August 1990

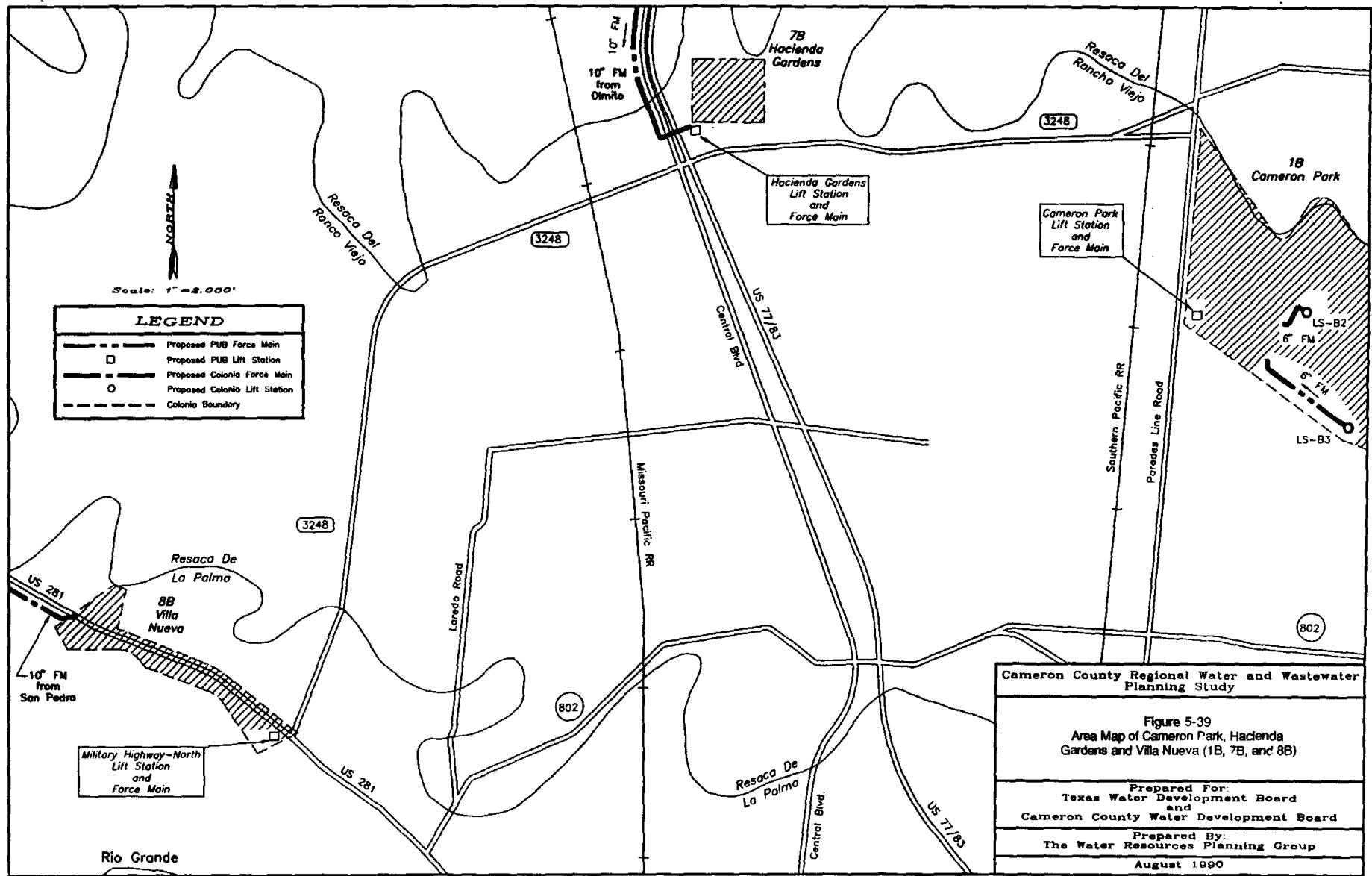

Scale: 1" = 2,000'

LEGEND	
--- (dashed line)	Proposed PUB Force Main
□ (square)	Proposed PUB Lift Station
--- (dashed line)	Proposed Colonia Force Main
○ (circle)	Proposed Colonia Lift Station
- - - - (dash-dot line)	Colonia Boundary

Cameron County Regional Water and Wastewater Planning Study

Figure 5-39  
Area Map of Cameron Park, Hacienda Gardens and Villa Nueva (1B, 7B, and 8B)

Prepared For:  
Texas Water Development Board  
and  
Cameron County Water Development Board

Prepared By:  
The Water Resources Planning Group

August 1990

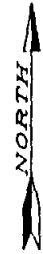
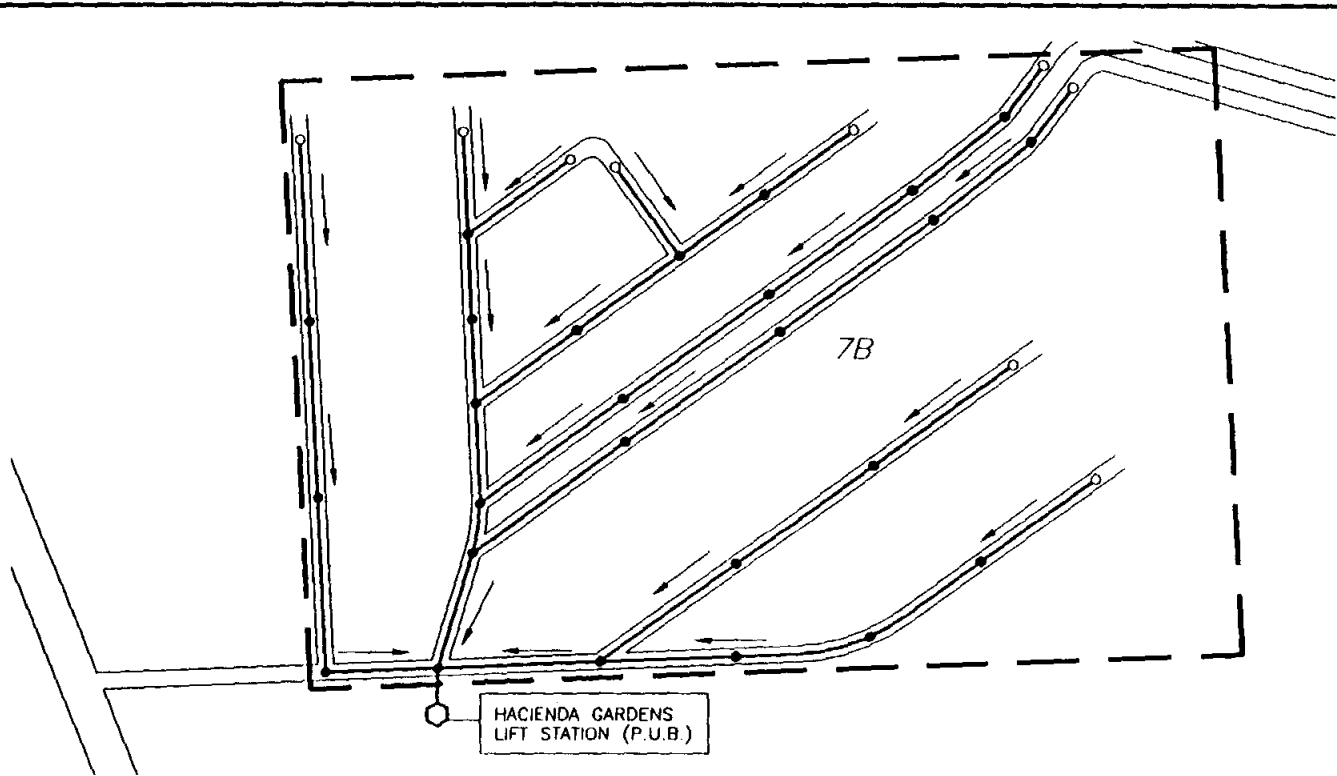

Scale: 1" = 400'

Colonia Designation	Colonia Name	Area (Ac)	2020 Population	2020 Population Density (Cap/Ac)	2020 Units	2020 Unit Density (Units/Ac)
7B	Hacienda Gardens	51	944	18.51	193	3.78

Internal Wastewater Collection System Quantities Estimate	
ITEM	QUANTITY
6" Service Connection	193 EA
8" SDR-35 PVC Sanitary Sewer	10,000 LF
10" SDR-35 PVC Sanitary Sewer	N/A
12" SDR-35 PVC Sanitary Sewer	N/A
15" SDR-35 PVC Sanitary Sewer	N/A
18" SDR-35 PVC Sanitary Sewer	N/A
Clean Out	9 EA
Manhole	26 EA
4" PVC Force Main	N/A
6" PVC Force Main	N/A
8" PVC Force Main	N/A
10" PVC Force Main	N/A
12" PVC Force Main	N/A
L.S. HACIENDA GARDENS	BY P.U.B.
<b>TOTAL ESTIMATED COST</b>	<b>\$ 455,694</b>

Cameron County Regional Water and Wastewater Planning Study

Figure 5-40  
Site Map of Hacienda Gardens (7B)

Prepared For:  
Texas Water Development Board  
and Cameron County Water Development Board

Prepared By:  
The Water Resources Planning Group

August 1990

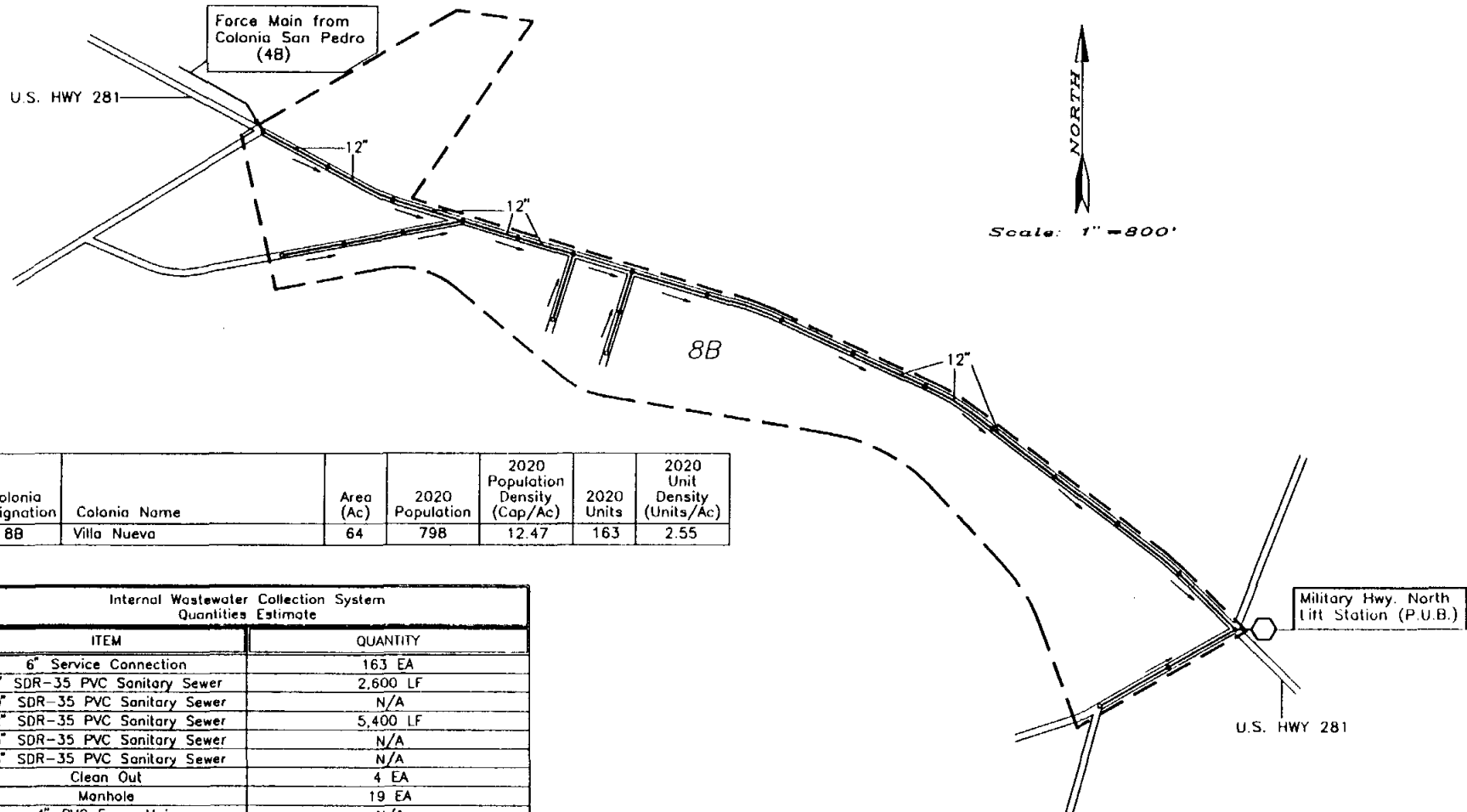

Colonia Designation	Colonia Name	Area (Ac)	2020 Population	2020 Population Density (Cap/Ac)	2020 Units	2020 Unit Density (Units/Ac)
8B	Villa Nueva	64	798	12.47	163	2.55

Internal Wastewater Collection System Quantities Estimate	
ITEM	QUANTITY
6" Service Connection	163 EA
8" SDR-35 PVC Sanitary Sewer	2,600 LF
10" SDR-35 PVC Sanitary Sewer	N/A
12" SDR-35 PVC Sanitary Sewer	5,400 LF
15" SDR-35 PVC Sanitary Sewer	N/A
18" SDR-35 PVC Sanitary Sewer	N/A
Clean Out	4 EA
Manhole	19 EA
4" PVC Force Main	N/A
6" PVC Force Main	N/A
8" PVC Force Main	N/A
10" PVC Force Main	N/A
12" PVC Force Main	N/A
MILITARY HWY. L.S.	BY P.U.B.
<b>TOTAL ESTIMATED COST</b>	<b>\$ 493,366</b>

Cameron County Regional Water and Wastewater Planning Study

Figure 5-41  
Site Map of Villa Nueva (8B)

Prepared For:  
Texas Water Development Board  
and Cameron County Water Development Board

Prepared By:  
The Water Resources Planning Group

August 1990

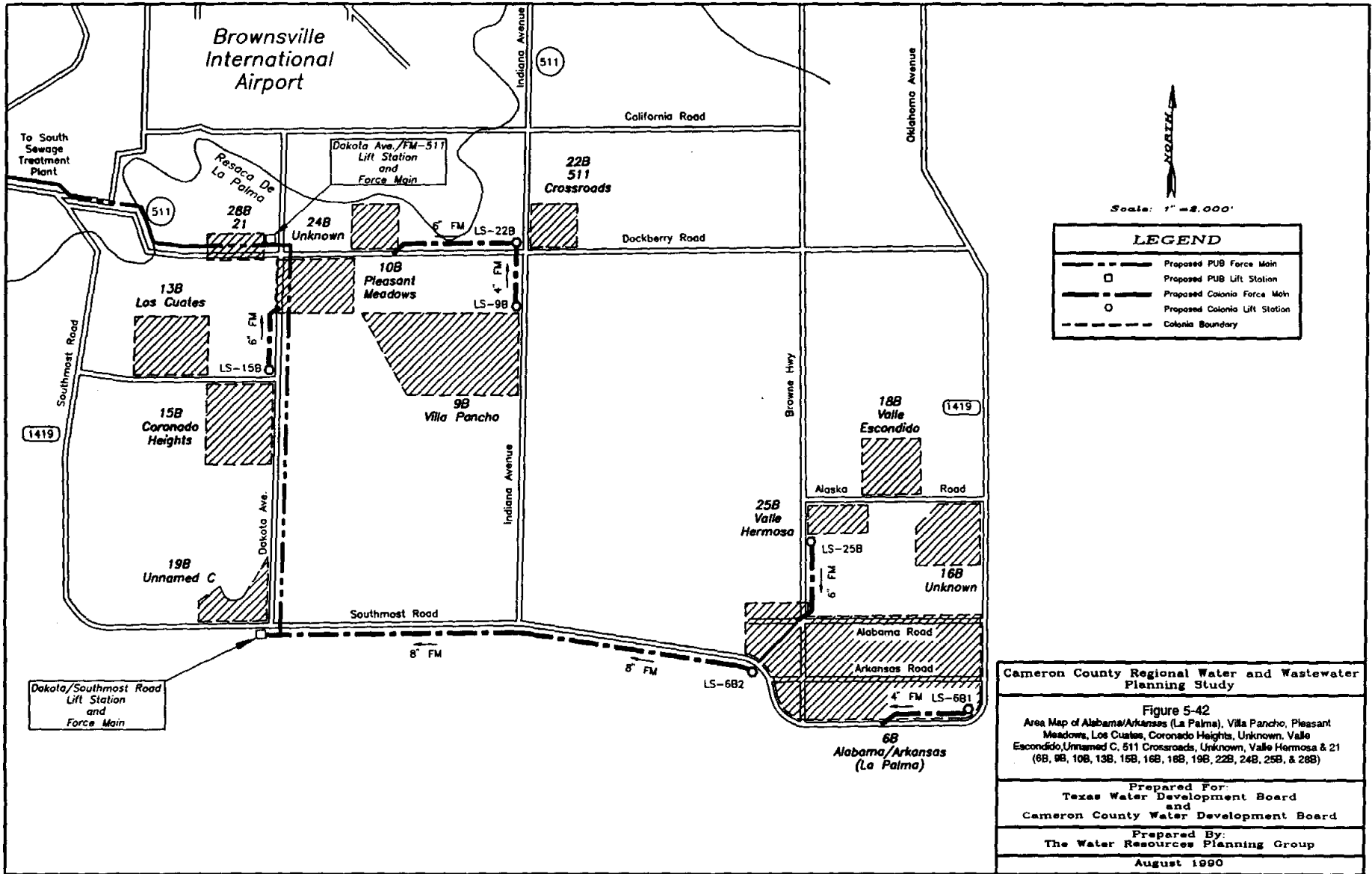

**LEGEND**

	Proposed PUB Force Main
	Proposed PUB Lift Station
	Proposed Colonia Force Main
	Proposed Colonia Lift Station
	Colonia Boundary

**Cameron County Regional Water and Wastewater Planning Study**

Figure 5-42  
 Area Map of Alabama/Arkansas (La Palma), Villa Pancho, Pleasant Meadows, Los Cuates, Coronado Heights, Unknown, Valle Escondido, Unnamed C, 511 Crossroads, Unknown, Valle Hermosa & 21 (6B, 9B, 10B, 13B, 15B, 16B, 18B, 19B, 22B, 24B, 25B, & 28B)

Prepared For:  
 Texas Water Development Board  
 and  
 Cameron County Water Development Board

Prepared By:  
 The Water Resources Planning Group  
 August 1990



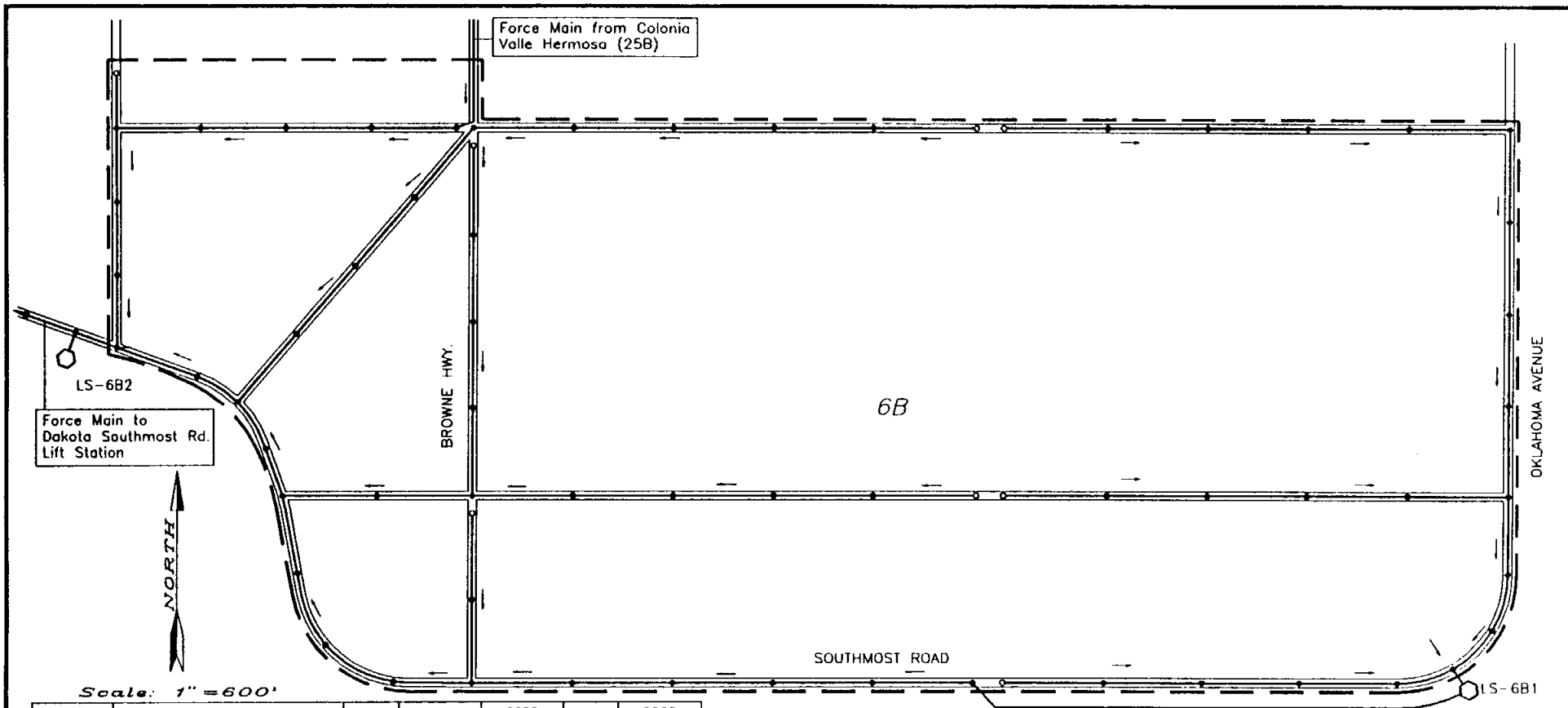

Colonia Designation	Colonia Name	Area (Ac)	2020 Population	2020 Population Density (Cap/Ac)	2020 Units	2020 Unit Density (Units/Ac)
6B	Alabama/Arkansas (La Palma)	242	1,022	4.22	208	0.86

Internal Wastewater Collection System Quantities Estimate	
ITEM	QUANTITY
6" Service Connection	208 EA
8" SDR-35 PVC Sanitary Sewer	22,200 LF
10" SDR-35 PVC Sanitary Sewer	N/A
12" SDR-35 PVC Sanitary Sewer	N/A
15" SDR-35 PVC Sanitary Sewer	N/A
18" SDR-35 PVC Sanitary Sewer	N/A
Clean Out	8 EA
Manhole	59 EA
4" PVC Force Main	2,100 LF
6" PVC Force Main	10,000 LF
8" PVC Force Main	N/A
10" PVC Force Main	N/A
12" PVC Force Main	N/A
LS-6B1 110 GPM (1 HP)	1 EA
LS-6B2 495 GPM (11.5HP)	1 EA
<b>TOTAL ESTIMATED COST</b>	<b>\$ 1,290,635</b>

Cameron County Regional Water and Wastewater Planning Study

Figure 5-43  
Site Map of Alabama/ Arkansas (La Palma)  
(6B)

Prepared For:  
Texas Water Development Board  
and Cameron County Water Development Board

Prepared By:  
The Water Resources Planning Group

August 1990

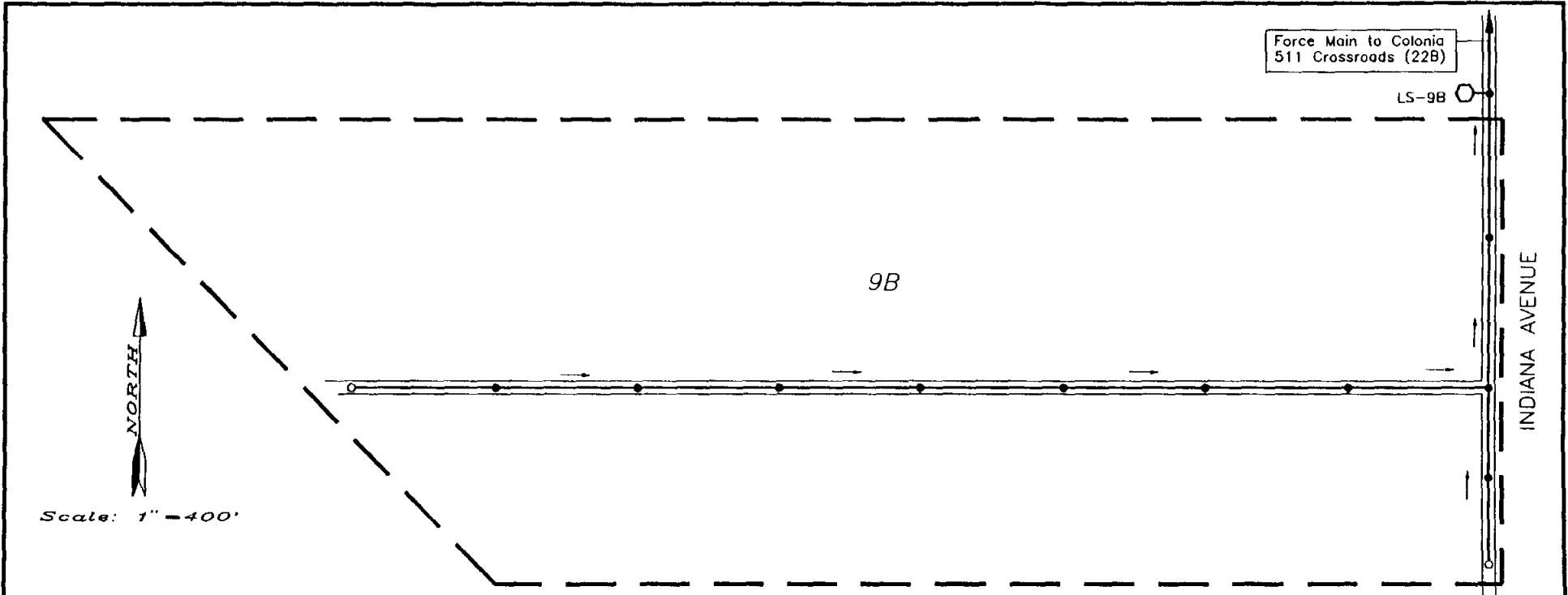

Colonia Designation	Colonia Name	Area (Ac)	2020 Population	2020 Population Density (Cap/Ac)	2020 Units	2020 Unit Density (Units/Ac)
9B	Villa Pancho	74	603	8.15	123	1.66

Internal Wastewater Collection System Quantities Estimate	
ITEM	QUANTITY
6" Service Connection	123 EA
8" SDR-35 PVC Sanitary Sewer	4,200 LF
10" SDR-35 PVC Sanitary Sewer	N/A
12" SDR-35 PVC Sanitary Sewer	N/A
15" SDR-35 PVC Sanitary Sewer	N/A
18" SDR-35 PVC Sanitary Sewer	N/A
Clean Out	2 EA
Manhole	11 EA
4" PVC Force Main	1,400 LF
6" PVC Force Main	N/A
8" PVC Force Main	N/A
10" PVC Force Main	N/A
12" PVC Force Main	N/A
LS-9B 180 GPM(2.5 HP)	1 EA
<b>TOTAL ESTIMATED COST</b>	<b>\$ 276,495</b>

**Cameron County Regional Water and Wastewater Planning Study**

**Figure 5-44  
Site Map of Villa Pancho (9B)**

**Prepared For:  
Texas Water Development Board  
and Cameron County Water Development Board**

**Prepared By:  
The Water Resources Planning Group**

**August 1990**

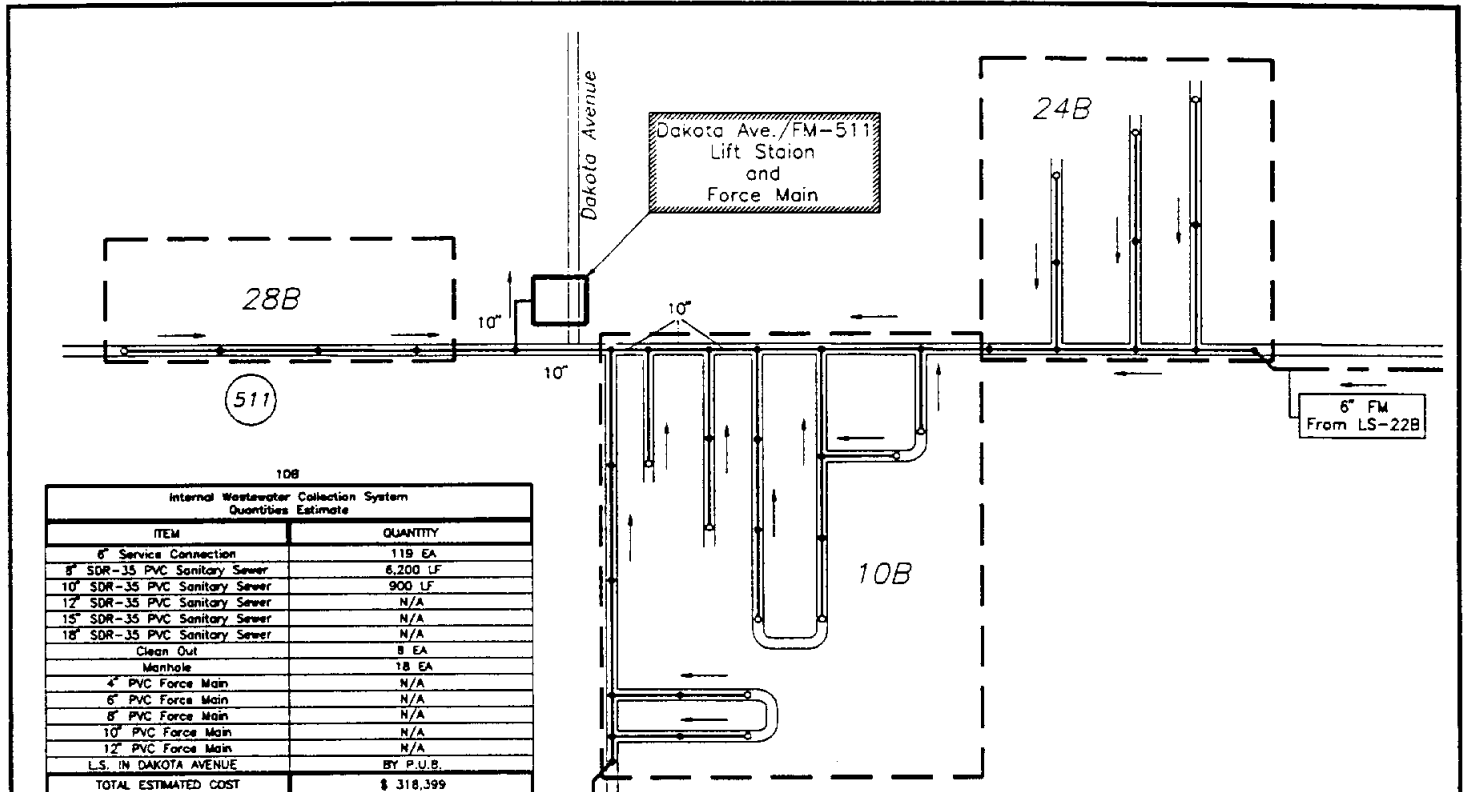

**10B**

Internal Wastewater Collection System Quantities Estimate	
ITEM	QUANTITY
6" Service Connection	119 EA
8" SDR-35 PVC Sanitary Sewer	6,200 LF
10" SDR-35 PVC Sanitary Sewer	900 LF
12" SDR-35 PVC Sanitary Sewer	N/A
15" SDR-35 PVC Sanitary Sewer	N/A
18" SDR-35 PVC Sanitary Sewer	N/A
Clean Out	8 EA
Manhole	18 EA
4" PVC Force Main	N/A
6" PVC Force Main	N/A
8" PVC Force Main	N/A
10" PVC Force Main	N/A
12" PVC Force Main	N/A
L.S. IN DAKOTA AVENUE	BY P.U.B.
<b>TOTAL ESTIMATED COST</b>	<b>\$ 318,399</b>

**24B**

Internal Wastewater Collection System Quantities Estimate	
ITEM	QUANTITY
6" Service Connection	40 EA
8" SDR-35 PVC Sanitary Sewer	2,930 LF
10" SDR-35 PVC Sanitary Sewer	N/A
12" SDR-35 PVC Sanitary Sewer	N/A
15" SDR-35 PVC Sanitary Sewer	N/A
18" SDR-35 PVC Sanitary Sewer	N/A
Clean Out	3 EA
Manhole	8 EA
4" PVC Force Main	N/A
6" PVC Force Main	N/A
8" PVC Force Main	N/A
10" PVC Force Main	N/A
12" PVC Force Main	N/A
<b>TOTAL ESTIMATED COST</b>	<b>\$ 123,601</b>

**28B**

Internal Wastewater Collection System Quantities Estimate	
ITEM	QUANTITY
6" Service Connection	18 EA
8" SDR-35 PVC Sanitary Sewer	1,200 LF
10" SDR-35 PVC Sanitary Sewer	N/A
12" SDR-35 PVC Sanitary Sewer	N/A
15" SDR-35 PVC Sanitary Sewer	N/A
18" SDR-35 PVC Sanitary Sewer	N/A
Clean Out	1 EA
Manhole	4 EA
4" PVC Force Main	N/A
6" PVC Force Main	N/A
8" PVC Force Main	N/A
10" PVC Force Main	N/A
12" PVC Force Main	N/A
<b>TOTAL ESTIMATED COST</b>	<b>\$ 53,271</b>

Colonia Designation	Colonia Name	Area (Ac)	2020 Population	2020 Population Density (Cap/Ac)	2020 Units	2020 Unit Density (Units/Ac)
10B	Pleasant Meadows	41	584	14.24	119	2.90
24B	Unknown (Brownsville Airport)	21	195	9.29	40	1.90
28B	21	9	88	9.78	18	2.00

6" FM From LS-15B

<b>Cameron County Regional Water and Wastewater Planning Study</b>
<b>Figure 5-45 Site Map of Pleasant Meadows, Unknown, and 21 (10B, 24B and 28B)</b>
<b>Prepared For: Texas Water Development Board and Cameron County Water Development Board</b>
<b>Prepared By: The Water Resources Planning Group</b>
<b>August 1990</b>

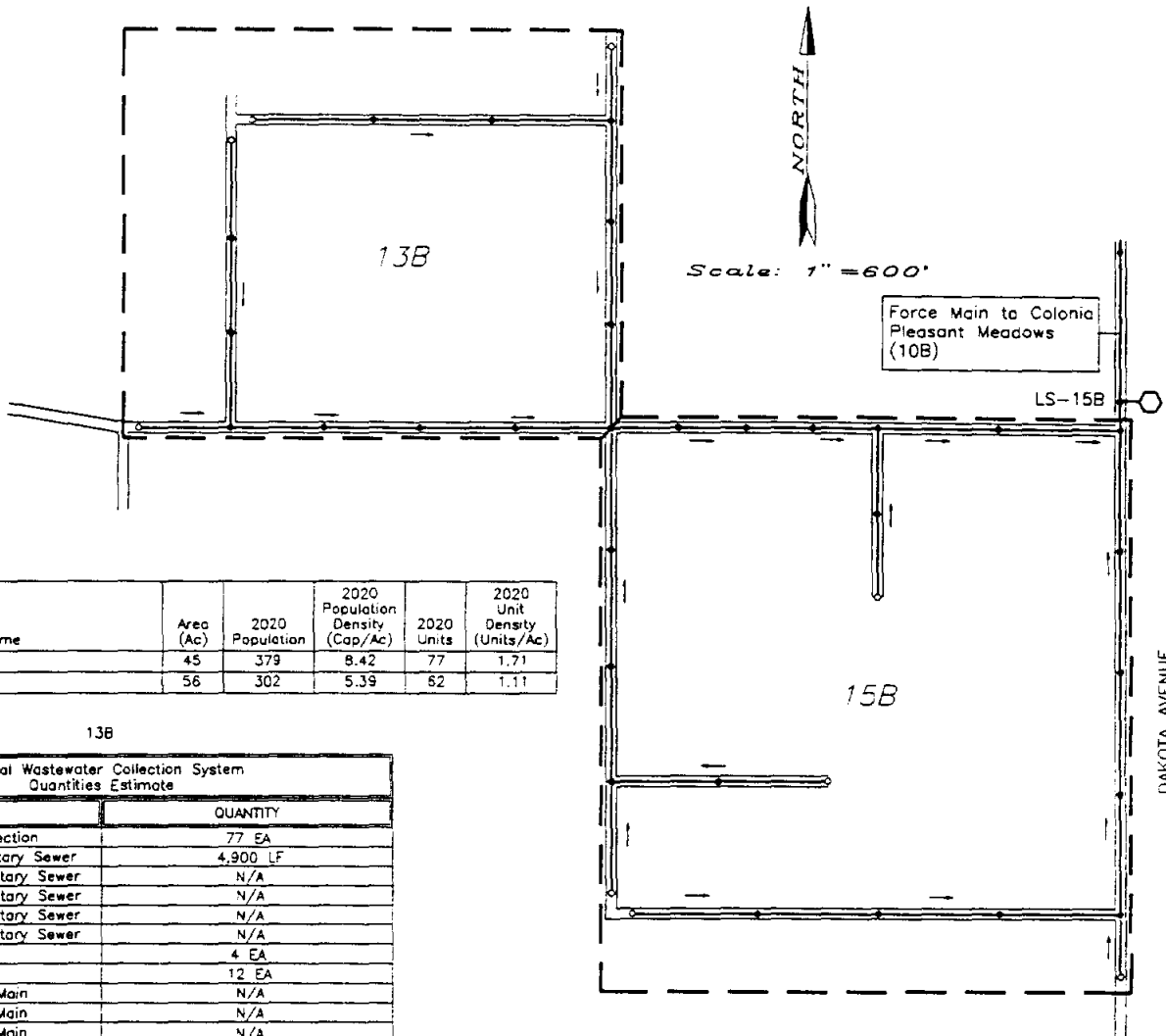

Colonia Designation	Colonia Name	Area (Ac)	2020 Population	2020 Population Density (Cap/Ac)	2020 Units	2020 Unit Density (Units/Ac)
13B	Los Cuates	45	379	8.42	77	1.71
15B	Coronado	56	302	5.39	62	1.11

13B

Internal Wastewater Collection System Quantities Estimate	
ITEM	QUANTITY
6" Service Connection	77 EA
8" SDR-35 PVC Sanitary Sewer	4,900 LF
10" SDR-35 PVC Sanitary Sewer	N/A
12" SDR-35 PVC Sanitary Sewer	N/A
15" SDR-35 PVC Sanitary Sewer	N/A
18" SDR-35 PVC Sanitary Sewer	N/A
Clean Out	4 EA
Mannhole	12 EA
4" PVC Force Main	N/A
6" PVC Force Main	N/A
8" PVC Force Main	N/A
10" PVC Force Main	N/A
12" PVC Force Main	N/A
<b>TOTAL ESTIMATED COST</b>	<b>\$ 209,802</b>

15B

Internal Wastewater Collection System Quantities Estimate	
ITEM	QUANTITY
6" Service Connection	62 EA
8" SDR-35 PVC Sanitary Sewer	7,600 LF
10" SDR-35 PVC Sanitary Sewer	N/A
12" SDR-35 PVC Sanitary Sewer	N/A
15" SDR-35 PVC Sanitary Sewer	N/A
18" SDR-35 PVC Sanitary Sewer	N/A
Clean Out	5 EA
Mannhole	19 EA
4" PVC Force Main	N/A
6" PVC Force Main	1,500 LF
8" PVC Force Main	N/A
10" PVC Force Main	N/A
12" PVC Force Main	N/A
LS-15B 205 GPM (2 HP)	1 EA
<b>TOTAL ESTIMATED COST</b>	<b>\$ 428,695</b>

<b>Cameron County Regional Water and Wastewater Planning Study</b>
<b>Figure 5-46 Site Map of Los Cuates and Coronado Heights (13B and 15B)</b>
<b>Prepared For: Texas Water Development Board and Cameron County Water Development Board</b>
<b>Prepared By: The Water Resources Planning Group</b>
<b>August 1990</b>

Colonia Designation	Colonia Name	Area (Ac)	2020 Population	2020 Population Density (Cap/Ac)	2020 Units	2020 Unit Density (Units/Ac)
16B	Unknown	30	282	9.40	58	1.93
18B	Valle Escondido	38	272	7.16	56	1.47
25B	Valle Hermosa	19	126	6.63	26	1.37

16B Internal Wastewater Collection System Quantities Estimate	
ITEM	QUANTITY
6" Service Connection	58 EA
8" SDR-35 PVC Sanitary Sewer	2,150 LF
Clean Out	1 EA
Manhole	8 EA
<b>TOTAL ESTIMATED COST</b>	<b>\$ 109,464</b>

18B Internal Wastewater Collection System Quantities Estimate	
ITEM	QUANTITY
6" Service Connection	56 EA
8" SDR-35 PVC Sanitary Sewer	6,850 LF
Clean Out	3 EA
Manhole	18 EA
<b>TOTAL ESTIMATED COST</b>	<b>\$ 261,736</b>

25B Internal Wastewater Collection System Quantities Estimate	
ITEM	QUANTITY
6" Service Connection	26 EA
8" SDR-35 PVC Sanitary Sewer	3,900 LF
10" SDR-35 PVC Sanitary Sewer	N/A
12" SDR-35 PVC Sanitary Sewer	N/A
15" SDR-35 PVC Sanitary Sewer	N/A
18" SDR-35 PVC Sanitary Sewer	N/A
Clean Out	3 EA
Manhole	10 EA
4" PVC Force Main	N/A
8" PVC Force Main	2,000 LF
8" PVC Force Main	N/A
10" PVC Force Main	N/A
12" PVC Force Main	N/A
LS-25B 205 GPM (2 HP)	1 EA
<b>TOTAL ESTIMATED COST</b>	<b>\$ 292,736</b>

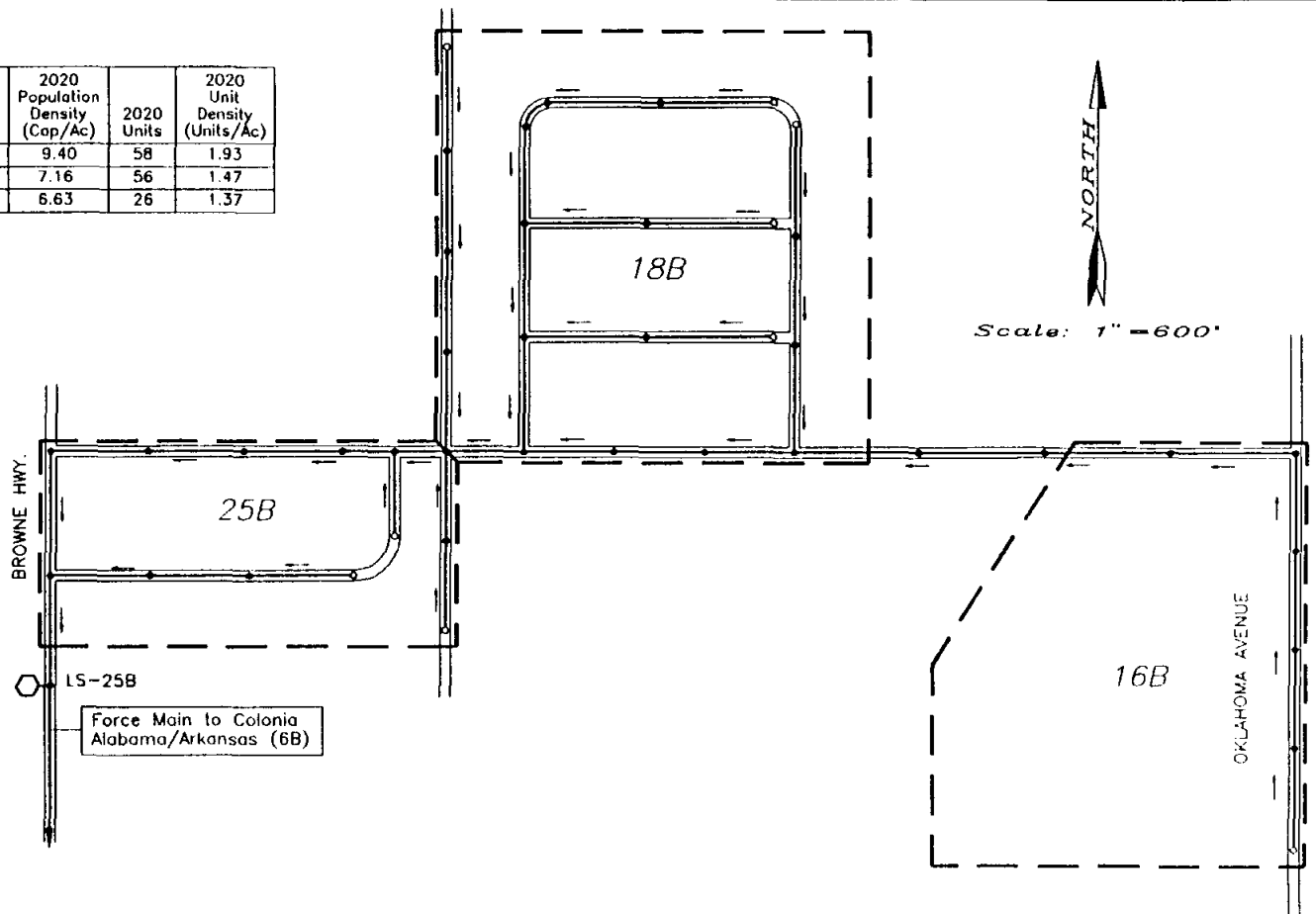

**Cameron County Regional Water and Wastewater  
Planning Study**

**Figure 5-47  
Site Map of Unknown, Valle Escondido and  
Valle Hermosa (16B, 18B and 25B)**

**Prepared For:  
Texas Water Development Board  
and Cameron County Water Development Board**

**Prepared By:  
The Water Resources Planning Group**

**August 1990**

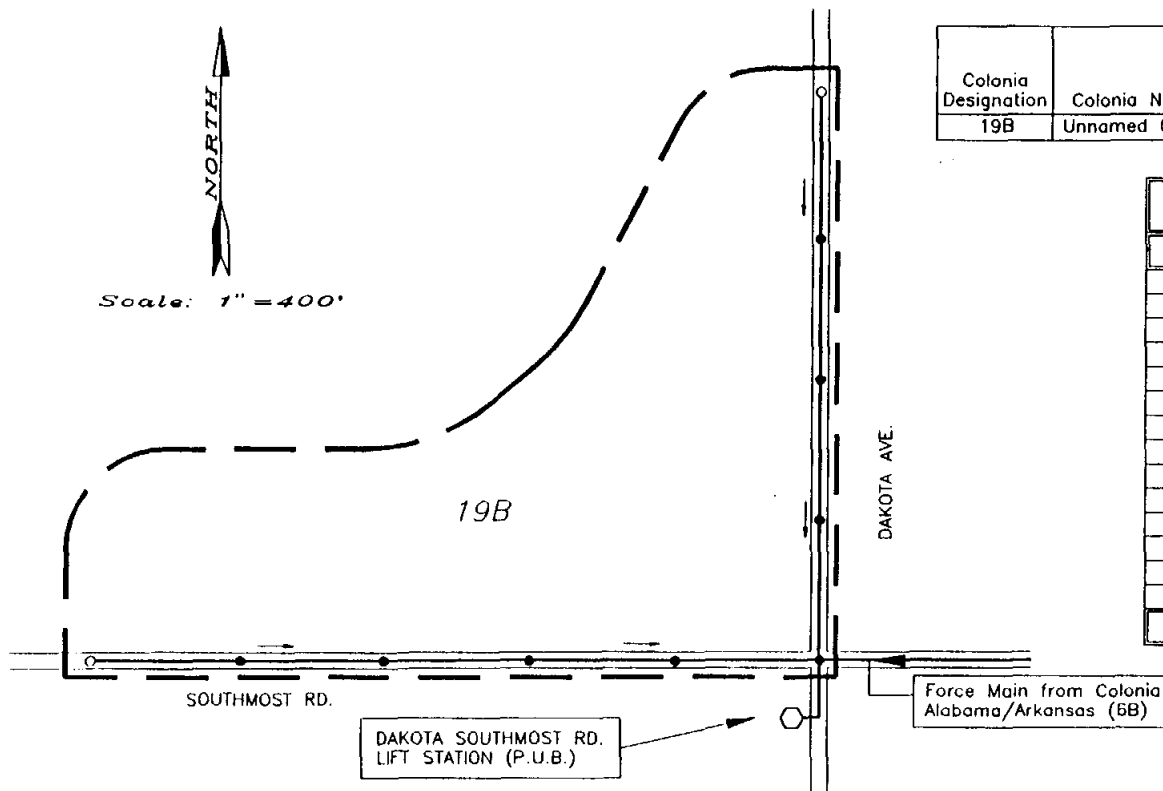

Colonia Designation	Colonia Name	Area (Ac)	2020 Population	2020 Population Density (Cap/Ac)	2020 Units	2020 Unit Density (Units/Ac)
19B	Unnamed C	24	263	10.96	54	2.25

Internal Wastewater Collection System Quantities Estimate	
ITEM	QUANTITY
6" Service Connection	54 EA
8" SDR-35 PVC Sanitary Sewer	2,800 LF
10" SDR-35 PVC Sanitary Sewer	N/A
12" SDR-35 PVC Sanitary Sewer	N/A
15" SDR-35 PVC Sanitary Sewer	N/A
18" SDR-35 PVC Sanitary Sewer	N/A
Clean Out	2 EA
Manhole	8 EA
4" PVC Force Main	N/A
6" PVC Force Main	N/A
8" PVC Force Main	N/A
10" PVC Force Main	N/A
12" PVC Force Main	N/A
L.S IN SOUTHMOST RD	BY P.U.B.
<b>TOTAL ESTIMATED COST</b>	<b>\$ 129,023</b>

Cameron County Regional Water and Wastewater Planning Study

Figure 5-48  
Site Map of Unnamed C (19B)

Prepared For:  
Texas Water Development Board  
and Cameron County Water Development Board

Prepared By:  
The Water Resources Planning Group

August 1990

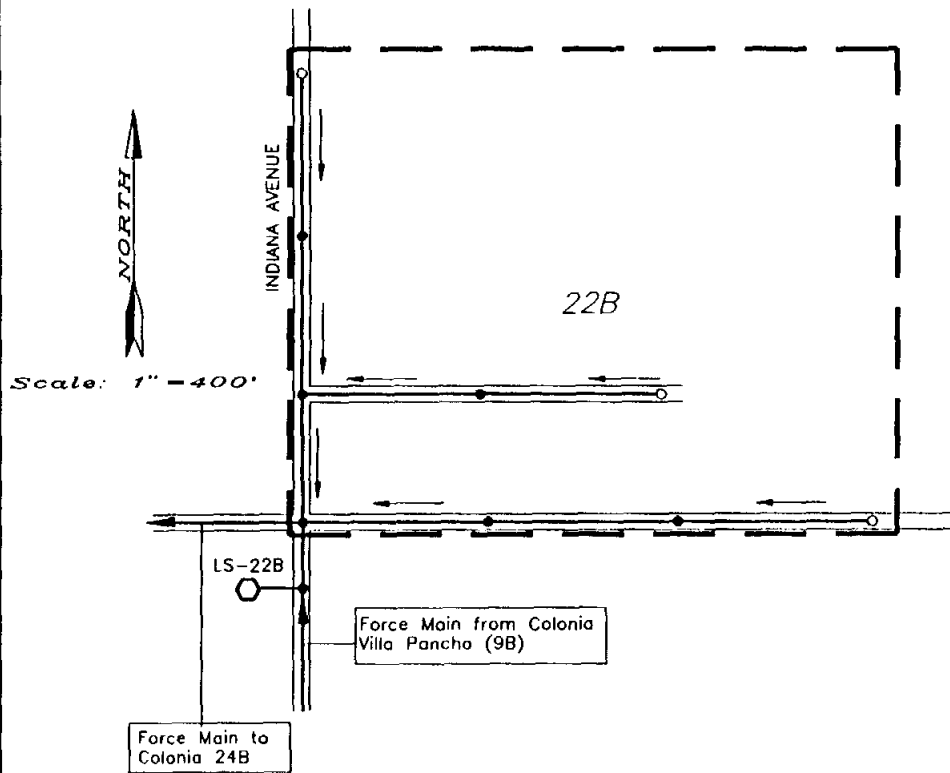

Colonia Designation	Colonia Name	Area (Ac)	2020 Population	2020 Population Density (Cap/Ac)	2020 Units	2020 Unit Density (Units/Ac)
22B	511 Crossroads	29	243	8.38	50	1.72

Internal Wastewater Collection System Quantities Estimate	
ITEM	QUANTITY
6" Service Connection	50 EA
8" SDR-35 PVC Sanitary Sewer	3,000 LF
10" SDR-35 PVC Sanitary Sewer	N/A
12" SDR-35 PVC Sanitary Sewer	N/A
15" SDR-35 PVC Sanitary Sewer	N/A
18" SDR-35 PVC Sanitary Sewer	N/A
Clean Out	3 EA
Manhole	7 EA
4" PVC Force Main	N/A
6" PVC Force Main	3,500 LF
8" PVC Force Main	N/A
10" PVC Force Main	N/A
12" PVC Force Main	N/A
LS-22B 250 GPM (3 HP)	1 EA
<b>TOTAL ESTIMATED COST</b>	<b>\$ 335,406</b>

**Cameron County Regional Water and Wastewater Planning Study**

**Figure 5-49  
Site Map of 511 Crossroads (22B)**

**Prepared For:  
Texas Water Development Board  
and Cameron County Water Development Board**

**Prepared By:  
The Water Resources Planning Group**

**August 1990**

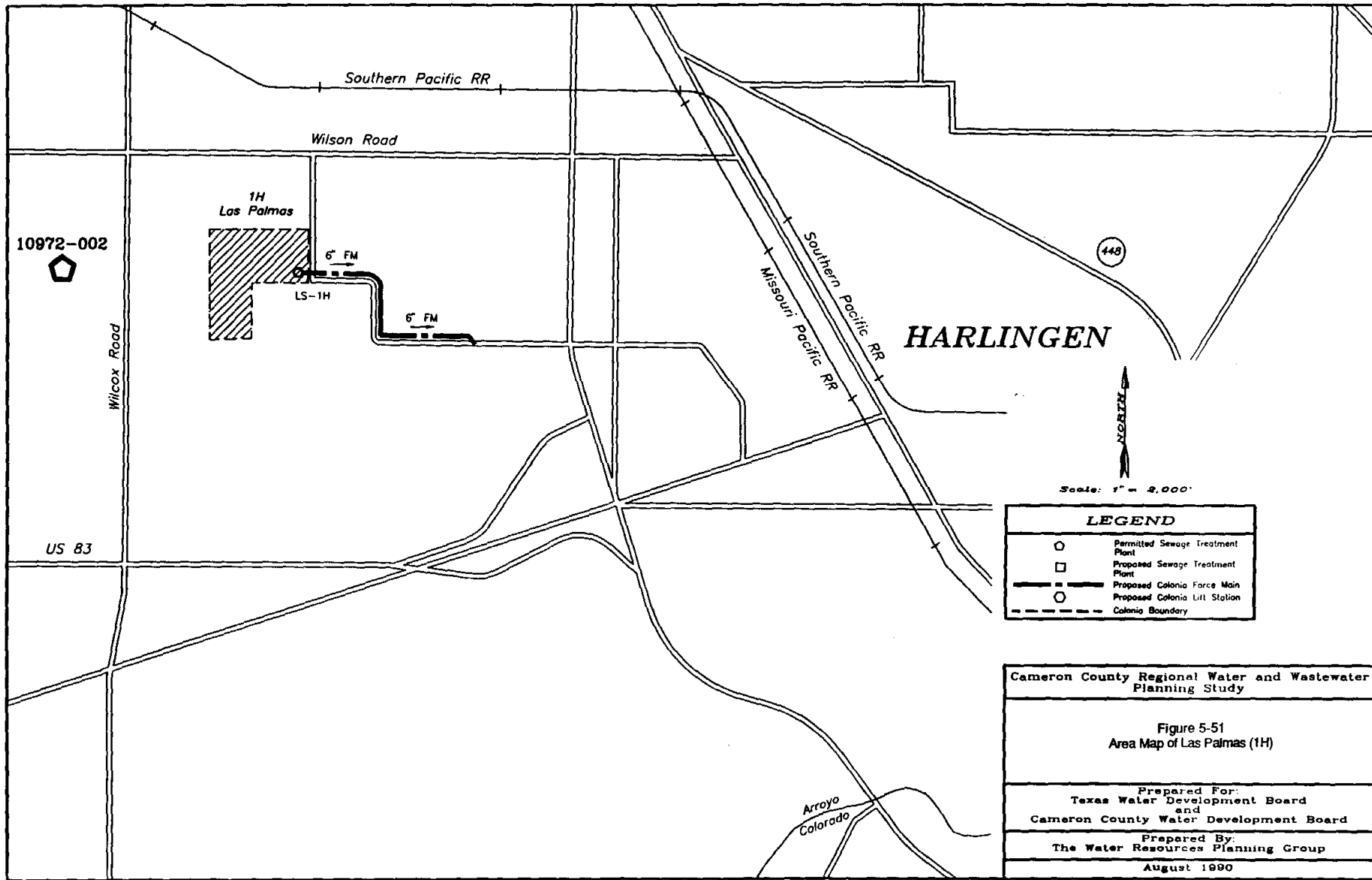



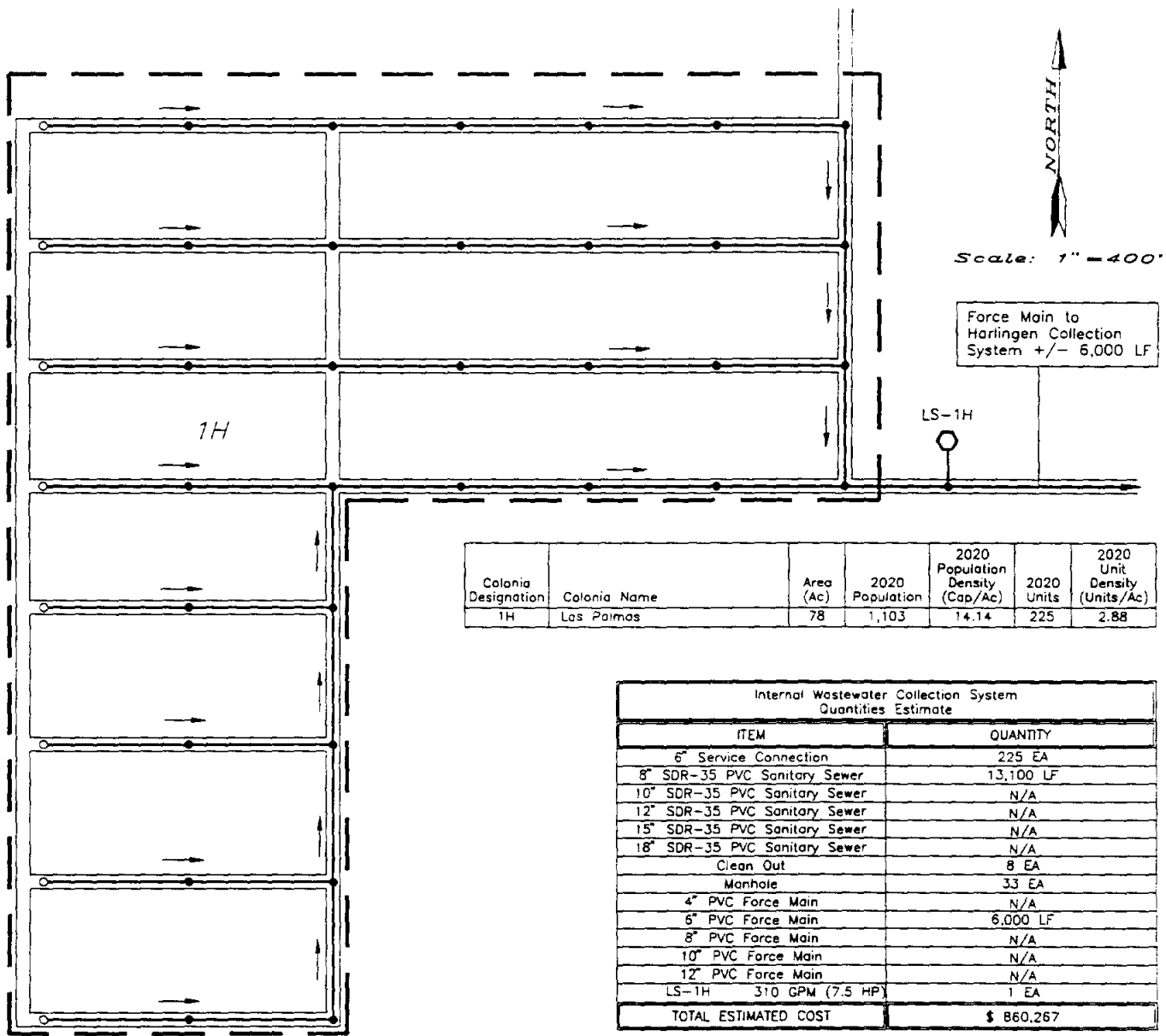

Colonia Designation	Colonia Name	Area (Ac)	2020 Population	2020 Population Density (Cap/Ac)	2020 Units	2020 Unit Density (Units/Ac)
1H	Las Palmas	78	1,103	14.14	225	2.88

Internal Wastewater Collection System Quantities Estimate	
ITEM	QUANTITY
6" Service Connection	225 EA
8" SDR-35 PVC Sanitary Sewer	13,100 LF
10" SDR-35 PVC Sanitary Sewer	N/A
12" SDR-35 PVC Sanitary Sewer	N/A
15" SDR-35 PVC Sanitary Sewer	N/A
18" SDR-35 PVC Sanitary Sewer	N/A
Clean Out	8 EA
Manhole	33 EA
4" PVC Force Main	N/A
6" PVC Force Main	6,000 LF
8" PVC Force Main	N/A
10" PVC Force Main	N/A
12" PVC Force Main	N/A
LS-1H 310 GPM (7.5 HP)	1 EA
<b>TOTAL ESTIMATED COST</b>	<b>\$ 860,267</b>

**Cameron County Regional Water and Wastewater Planning Study**

**Figure 5-52  
Site Map of Las Palmas (1H)**

**Prepared For:  
Texas Water Development Board  
and Cameron County Water Development Board**

**Prepared By:  
The Water Resources Planning Group**

**August 1990**

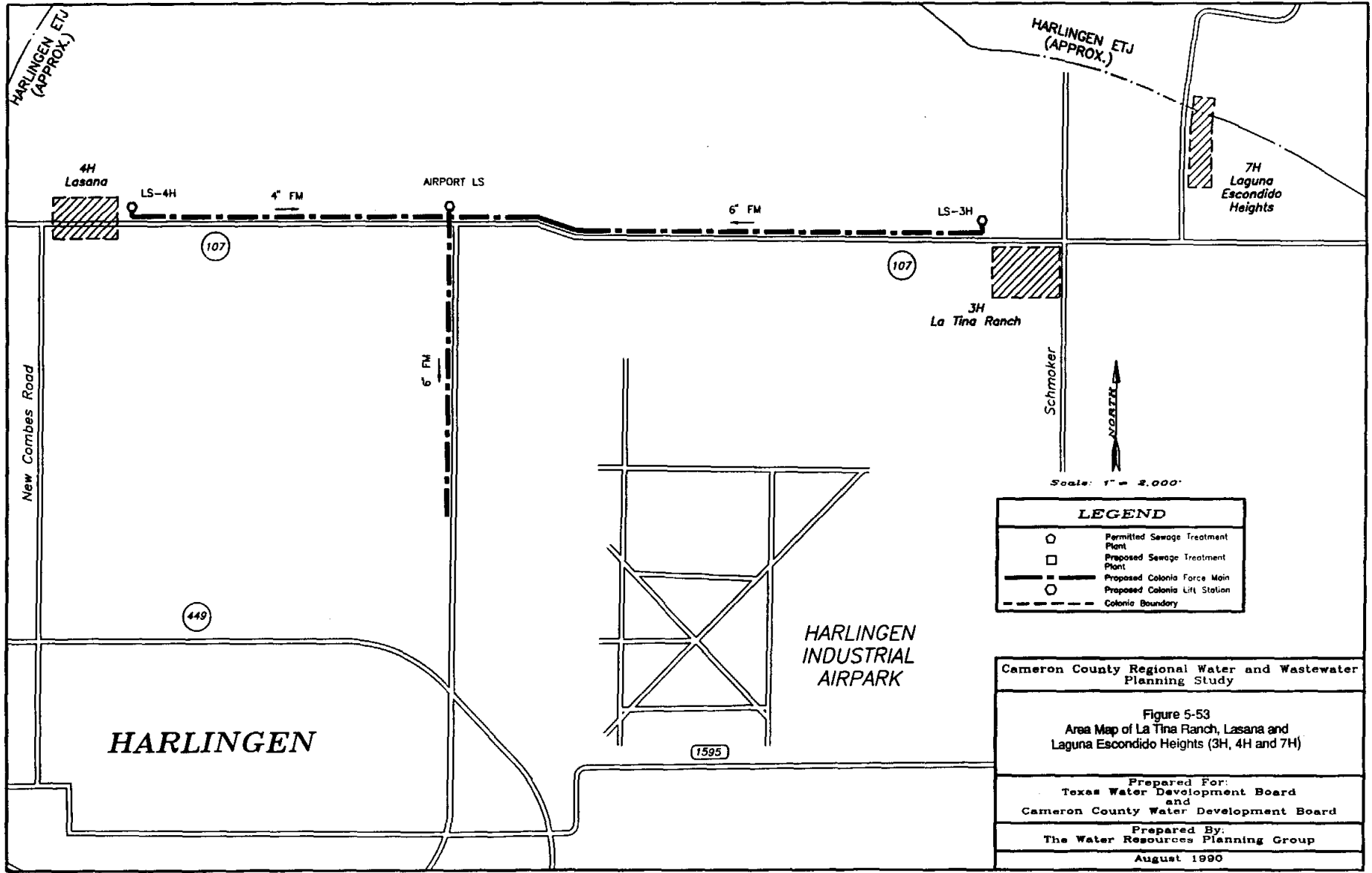

**LEGEND**

○	Permitted Sewage Treatment Plant
□	Proposed Sewage Treatment Plant
— — — — —	Proposed Colonia Force Main
○	Proposed Colonia Lift Station
- - - - -	Colonia Boundary

Cameron County Regional Water and Wastewater Planning Study

Figure 5-53  
Area Map of La Tina Ranch, Lasana and Laguna Escondido Heights (3H, 4H and 7H)

Prepared For:  
Texas Water Development Board  
and  
Cameron County Water Development Board

Prepared By:  
The Water Resources Planning Group

August 1990

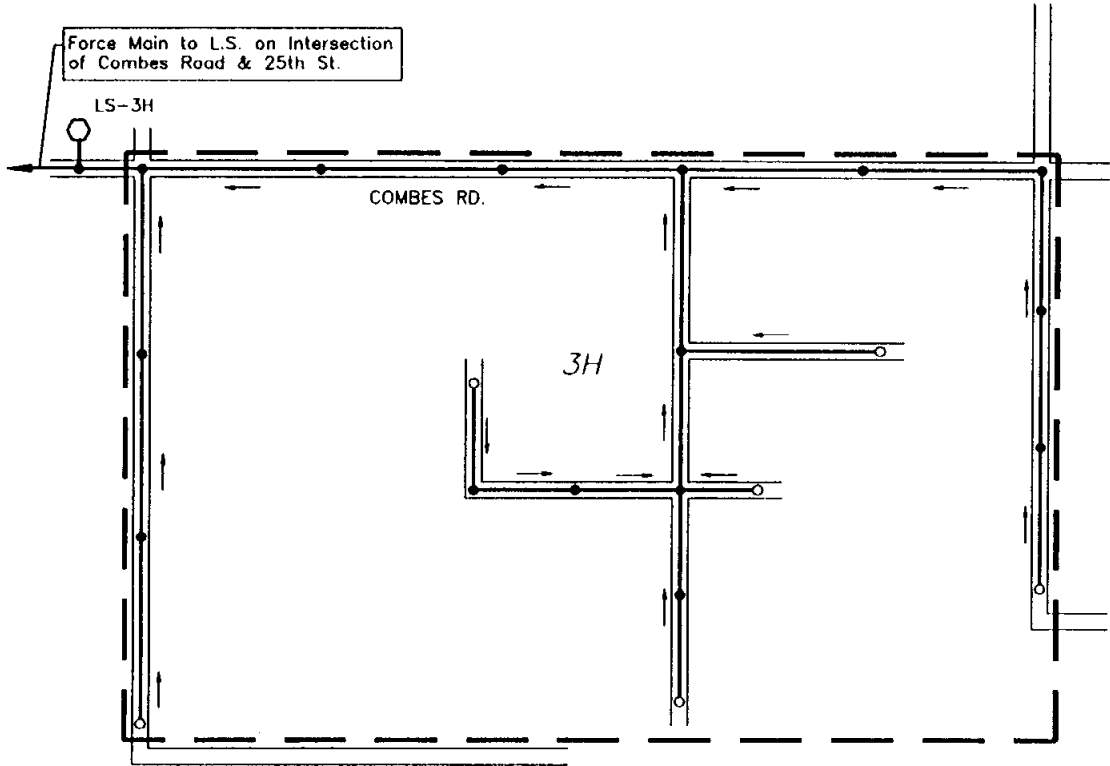

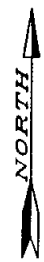
  
 NORTH  
 Scale: 1" = 400'

Colonia Designation	Colonia Name	Area (Ac)	2020 Population	2020 Population Density (Cap/Ac)	2020 Units	2020 Unit Density (Units/Ac)
3H	26	41	504	12.29	103	2.51

Internal Wastewater Collection System Quantities Estimate	
ITEM	QUANTITY
6" Service Connection	103 EA
8" SDR-35 PVC Sanitary Sewer	6,250 LF
10" SDR-35 PVC Sanitary Sewer	N/A
12" SDR-35 PVC Sanitary Sewer	N/A
15" SDR-35 PVC Sanitary Sewer	N/A
18" SDR-35 PVC Sanitary Sewer	N/A
Clean Out	6 EA
Manhole	16 EA
4" PVC Force Main	26,500 LF
6" PVC Force Main	N/A
8" PVC Force Main	N/A
10" PVC Force Main	N/A
12" PVC Force Main	N/A
LS-3H 150 GPM(21 HP)	1 EA
<b>TOTAL ESTIMATED COST</b>	<b>\$ 824,870</b>

**Cameron County Regional Water and Wastewater Planning Study**  
  
**Figure 5-54**  
**Site Map of La Tina Ranch (3H)**  
  
**Prepared For:**  
**Texas Water Development Board**  
**and Cameron County Water Development Board**  
  
**Prepared By:**  
**The Water Resources Planning Group**  
  
**August 1990**

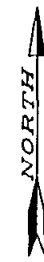
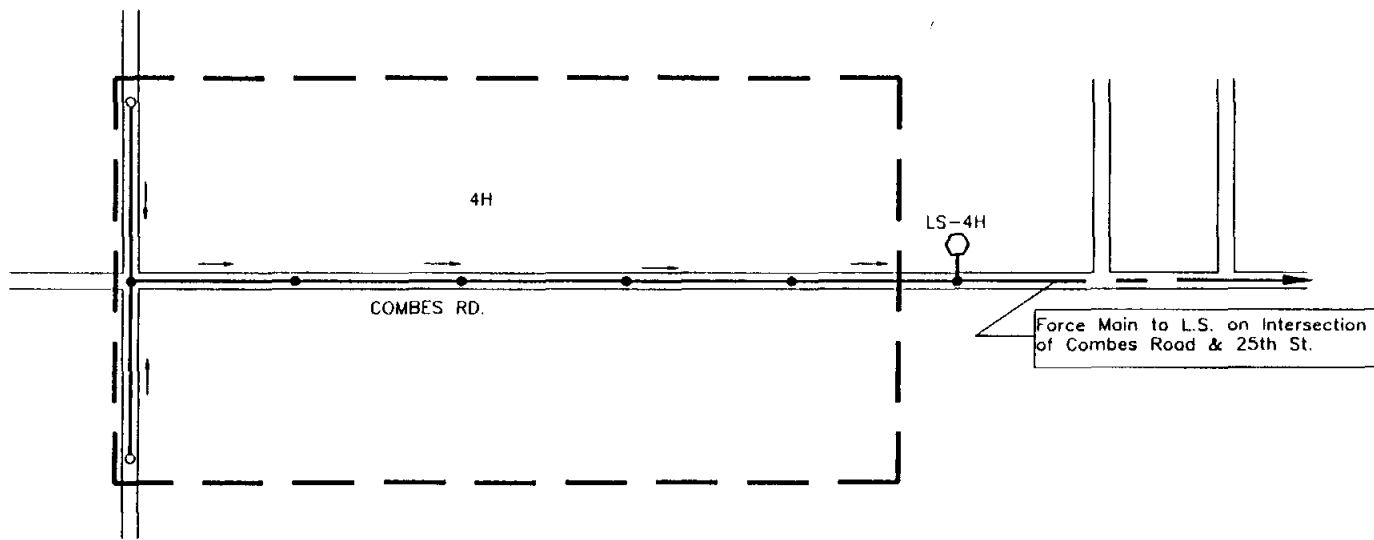

Scale: 1" = 400'

Colonia Designation	Colonia Name	Area (Ac)	2020 Population	2020 Population Density (Cap/Ac)	2020 Units	2020 Unit Density (Units/Ac)
4H	Lasana	25	243	9.72	50	2.00

Internal Wastewater Collection System Quantities Estimate	
ITEM	QUANTITY
6" Service Connection	50 EA
8" SDR-35 PVC Sanitary Sewer	2,550 LF
10" SDR-35 PVC Sanitary Sewer	N/A
12" SDR-35 PVC Sanitary Sewer	N/A
15" SDR-35 PVC Sanitary Sewer	N/A
18" SDR-35 PVC Sanitary Sewer	N/A
Clean Out	2 EA
Manhole	6 EA
4" PVC Force Main	15,000 LF
6" PVC Force Main	N/A
8" PVC Force Main	N/A
10" PVC Force Main	N/A
12" PVC Force Main	N/A
LS-4H 75 GPM (7 HP)	1 EA
<b>TOTAL ESTIMATED COST</b>	<b>\$ 477,516</b>

**Cameron County Regional Water and Wastewater Planning Study**

---

Figure 5-55  
Site Map of Lasana (4H)

---

Prepared For:  
Texas Water Development Board  
and Cameron County Water Development Board

---

Prepared By:  
The Water Resources Planning Group

---

August 1990

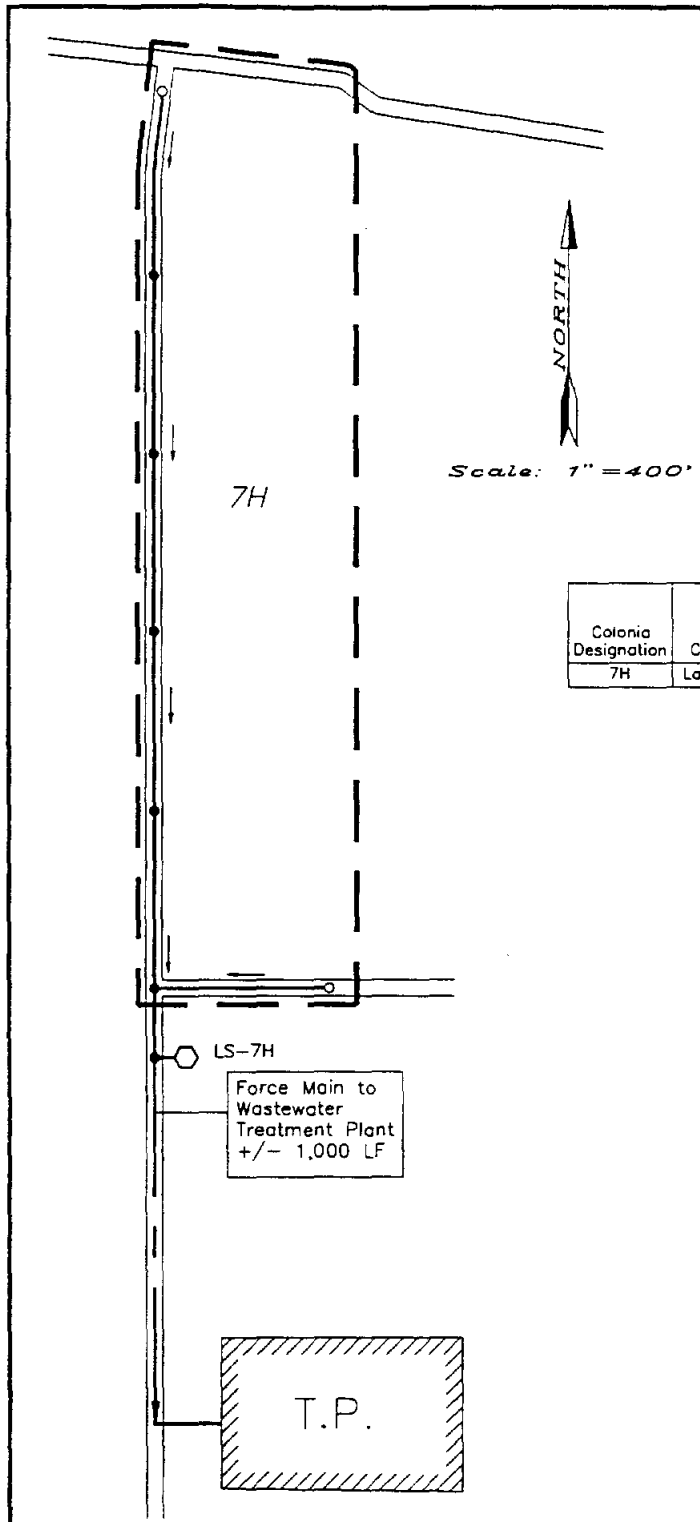

Internal Wastewater Collection System Quantities Estimate	
ITEM	QUANTITY
6" Service Connection	19 EA
8" SDR-35 PVC Sanitary Sewer	2,300 LF
10" SDR-35 PVC Sanitary Sewer	N/A
12" SDR-35 PVC Sanitary Sewer	N/A
15" SDR-35 PVC Sanitary Sewer	N/A
18" SDR-35 PVC Sanitary Sewer	N/A
Clean Out	2 EA
Manhole	6 EA
2" PVC Force Main	1,000 LF
6" PVC Force Main	N/A
8" PVC Force Main	N/A
10" PVC Force Main	N/A
12" PVC Force Main	N/A
LS-7H 30 GPM (1.0 HP)	1 EA
<b>TOTAL ESTIMATED COST</b>	<b>\$ 164,744</b>

Colonia Designation	Colonia Name	Area (Ac)	2020 Population	2020 Population Density (Cap/Ac)	2020 Units	2020 Unit Density (Units/Ac)
7H	Laguna Escondido Heights	16	95	5.94	19	1.19

<b>Cameron County Regional Water and Wastewater Planning Study</b>
<b>Figure 5-56 Site Map of Laguna Escondido Heights (7H)</b>
<b>Prepared For: Texas Water Development Board and Cameron County Water Development Board</b>
<b>Prepared By: The Water Resources Planning Group</b>
<b>August 1990</b>

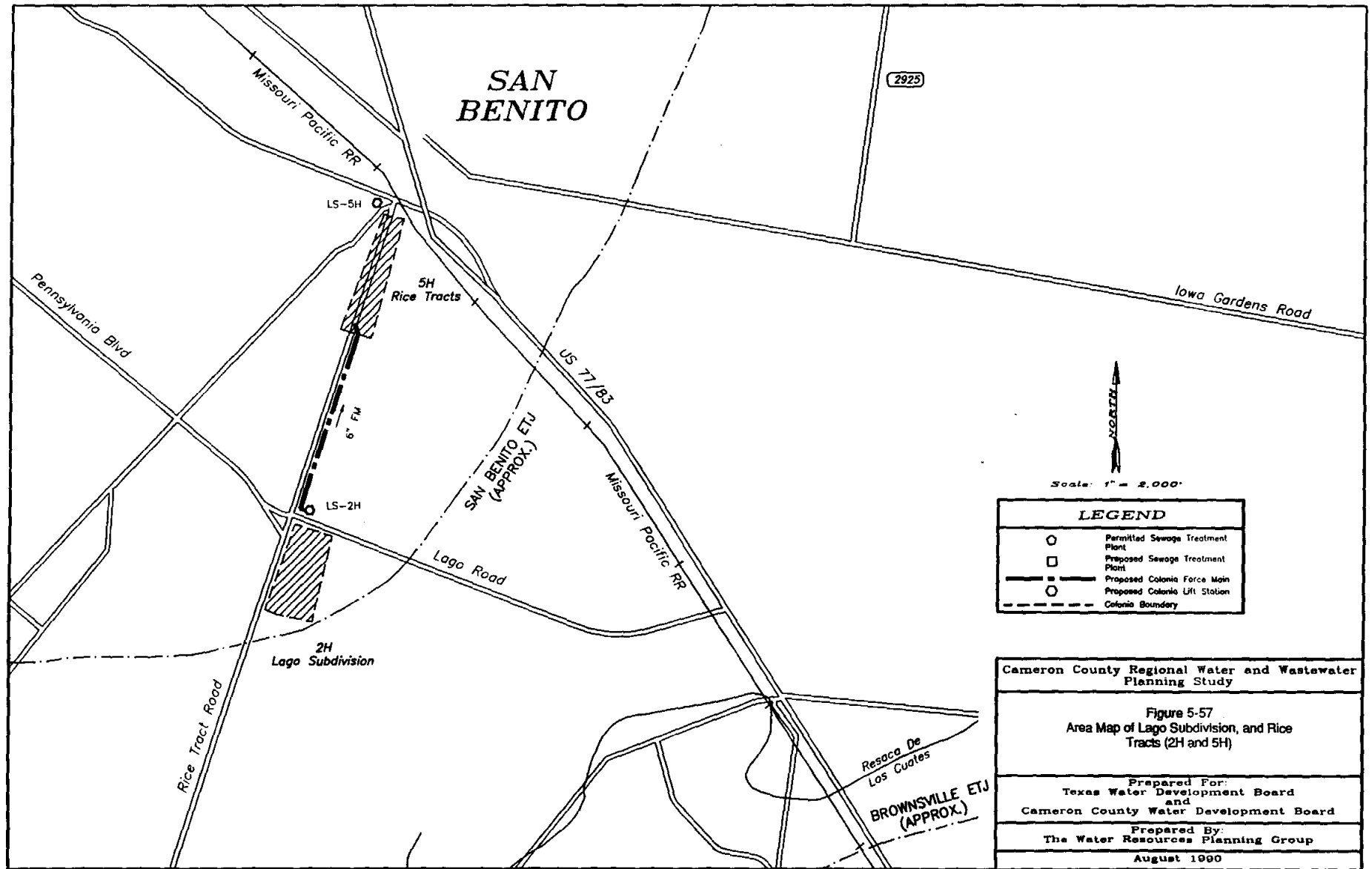

LEGEND	
○	Permitted Sewage Treatment Plant
□	Proposed Sewage Treatment Plant
—+—+—+—	Proposed Colonia Force Main
○	Proposed Colonia Lift Station
- - -	Colonia Boundary

Cameron County Regional Water and Wastewater Planning Study
Figure 5-57 Area Map of Lago Subdivision, and Rice Tracts (2H and 5H)
Prepared For: Texas Water Development Board and Cameron County Water Development Board
Prepared By: The Water Resources Planning Group
August 1990

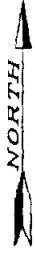

Scale: 1" = 400'

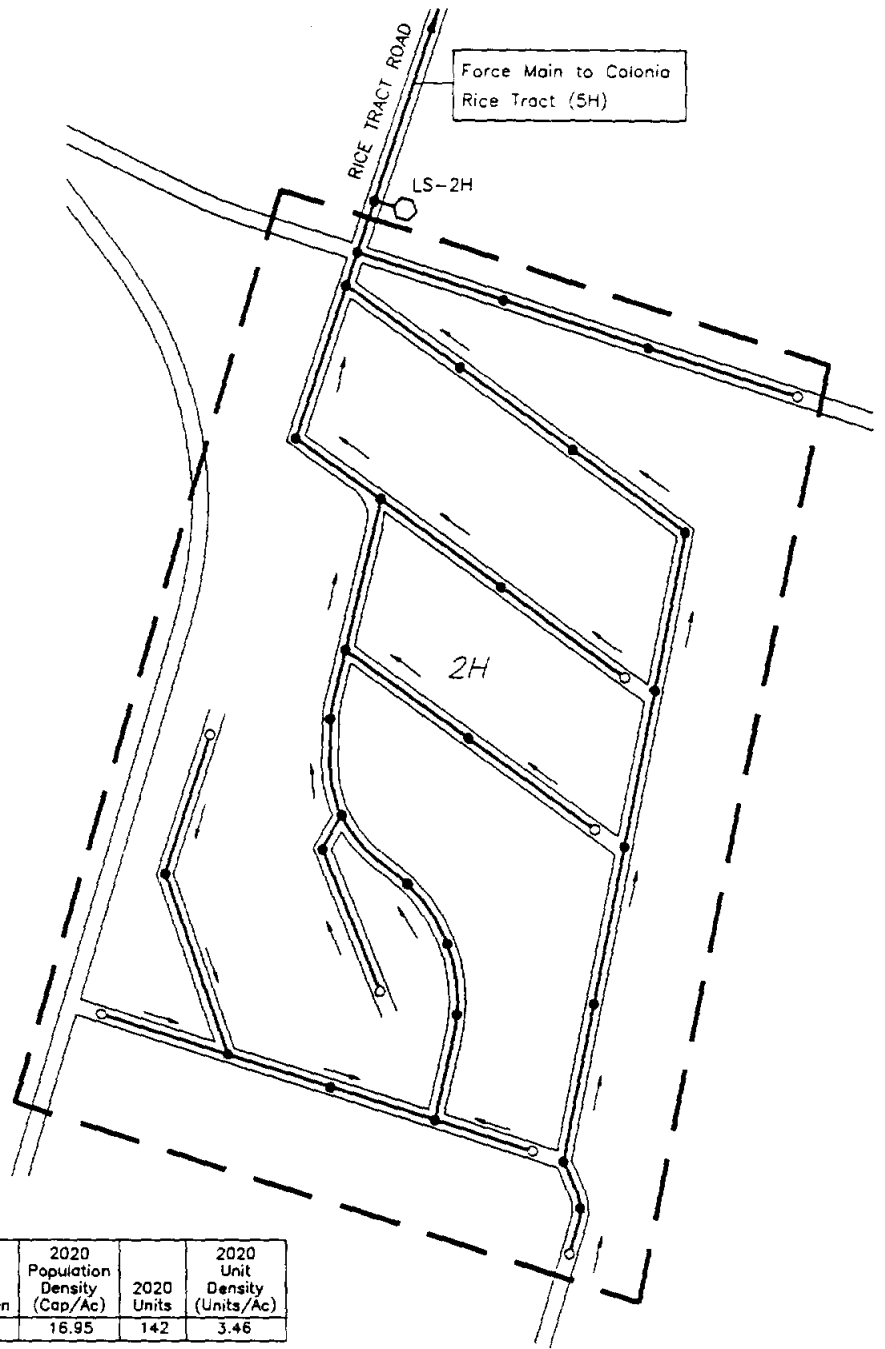

Colonia Designation	Colonia Name	Area (Ac)	2020 Population	2020 Population Density (Cap/Ac)	2020 Units	2020 Unit Density (Units/Ac)
2H	Lago Subdivision	41	695	16.95	142	3.46

Internal Wastewater Collection System Quantities Estimate	
ITEM	QUANTITY
6" Service Connection	124 EA
8" SDR-35 PVC Sanitary Sewer	8,815 LF
10" SDR-35 PVC Sanitary Sewer	N/A
12" SDR-35 PVC Sanitary Sewer	N/A
15" SDR-35 PVC Sanitary Sewer	N/A
18" SDR-35 PVC Sanitary Sewer	N/A
Clean Out	8 EA
Manhole	28 EA
4" PVC Force Main	N/A
6" PVC Force Main	10,000 LF
8" PVC Force Main	N/A
10" PVC Force Main	N/A
12" PVC Force Main	N/A
LS-2H 205 GPM (4.5 HP)	1 EA
<b>TOTAL ESTIMATED COST</b>	<b>\$ 718,859</b>

**Cameron County Regional Water and Wastewater Planning Study**

**Figure 5-58  
Site Map of Lago Subdivision (2H)**

**Prepared For:  
Texas Water Development Board  
and Cameron County Water Development Board**

**Prepared By:  
The Water Resources Planning Group**

**August 1990**

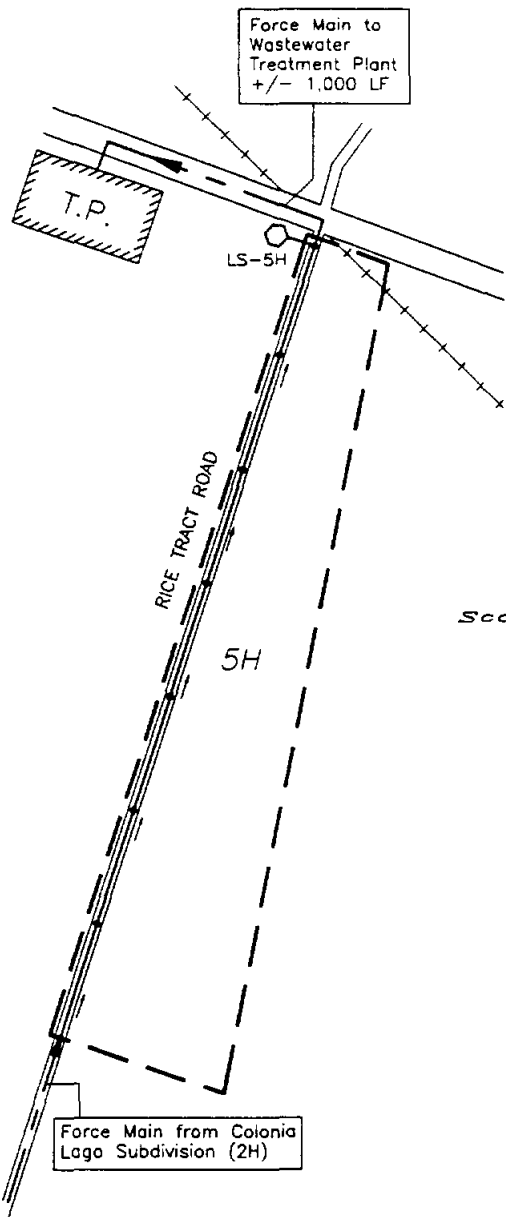

Colonia Designation	Colonia Name	Area (Ac)	2020 Population	2020 Population Density (Cap/Ac)	2020 Units	2020 Unit Density (Units/Ac)
5H	Rice Tract	32	234	7.31	48	1.50

Internal Wastewater Collection System Quantities Estimate	
ITEM	QUANTITY
6" Service Connection	48 EA
8" SDR-35 PVC Sanitary Sewer	2,800 LF
10" SDR-35 PVC Sanitary Sewer	N/A
12" SDR-35 PVC Sanitary Sewer	N/A
15" SDR-35 PVC Sanitary Sewer	N/A
18" SDR-35 PVC Sanitary Sewer	N/A
Clean Out	N/A
Manhole	8 EA
4" PVC Force Main	N/A
6" PVC Force Main	1,000 LF
8" PVC Force Main	N/A
10" PVC Force Main	N/A
12" PVC Force Main	N/A
LS-5H 345 GPM (4.0 HP)	1 EA
<b>TOTAL ESTIMATED COST</b>	<b>\$ 323,960</b>

**Cameron County Regional Water and Wastewater Planning Study**

**Figure 5-59  
Site Map of Rice Tracts (5H)**

**Prepared For:  
Texas Water Development Board  
and Cameron County Water Development Board**

**Prepared By:  
The Water Resources Planning Group**

**August 1990**



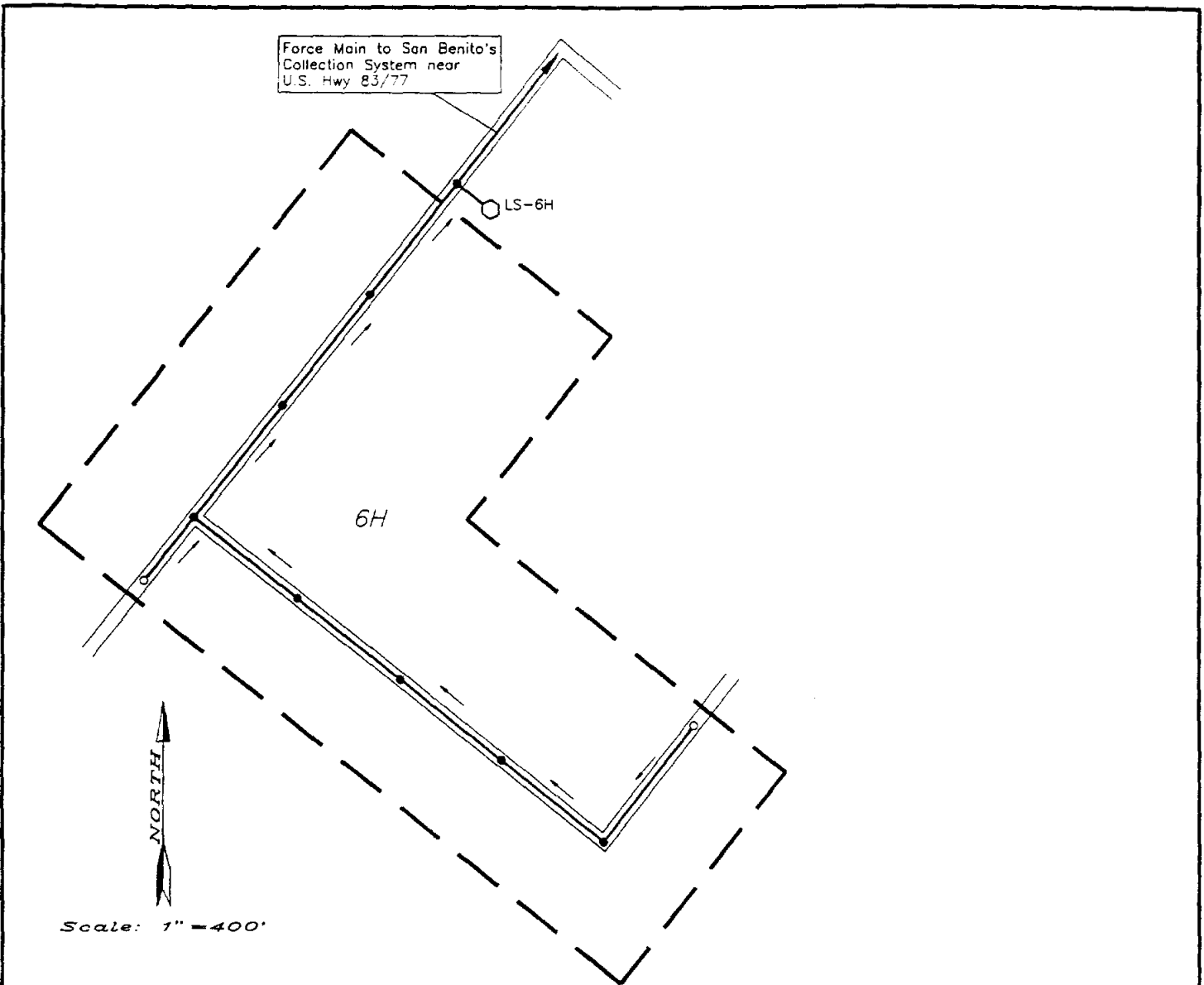

Colonia Designation	Colonia Name	Area (Ac)	2020 Population	2020 Population Density (Cap/Ac)	2020 Units	2020 Unit Density (Units/Ac)
6H	Leal Subdivision	24	217	9.04	44	1.83

Internal Wastewater Collection System Quantities Estimate	
ITEM	QUANTITY
6" Service Connection	44 EA
8" SDR-35 PVC Sanitary Sewer	2,150 LF
10" SDR-35 PVC Sanitary Sewer	N/A
12" SDR-35 PVC Sanitary Sewer	N/A
15" SDR-35 PVC Sanitary Sewer	N/A
18" SDR-35 PVC Sanitary Sewer	N/A
Clean Out	2 EA
Manhole	8 EA
4" PVC Force Main	8,000 LF
6" PVC Force Main	N/A
8" PVC Force Main	N/A
10" PVC Force Main	N/A
12" PVC Force Main	N/A
LS-6H 65 GPM (1.5HP)	1 EA
<b>TOTAL ESTIMATED COST</b>	<b>\$ 285,079</b>

**Cameron County Regional Water and Wastewater Planning Study**

**Figure 5-61  
Site Map of Leal Subdivision (6H)**

**Prepared For:  
Texas Water Development Board  
and Cameron County Water Development Board**

**Prepared By:  
The Water Resources Planning Group**

**August 1990**

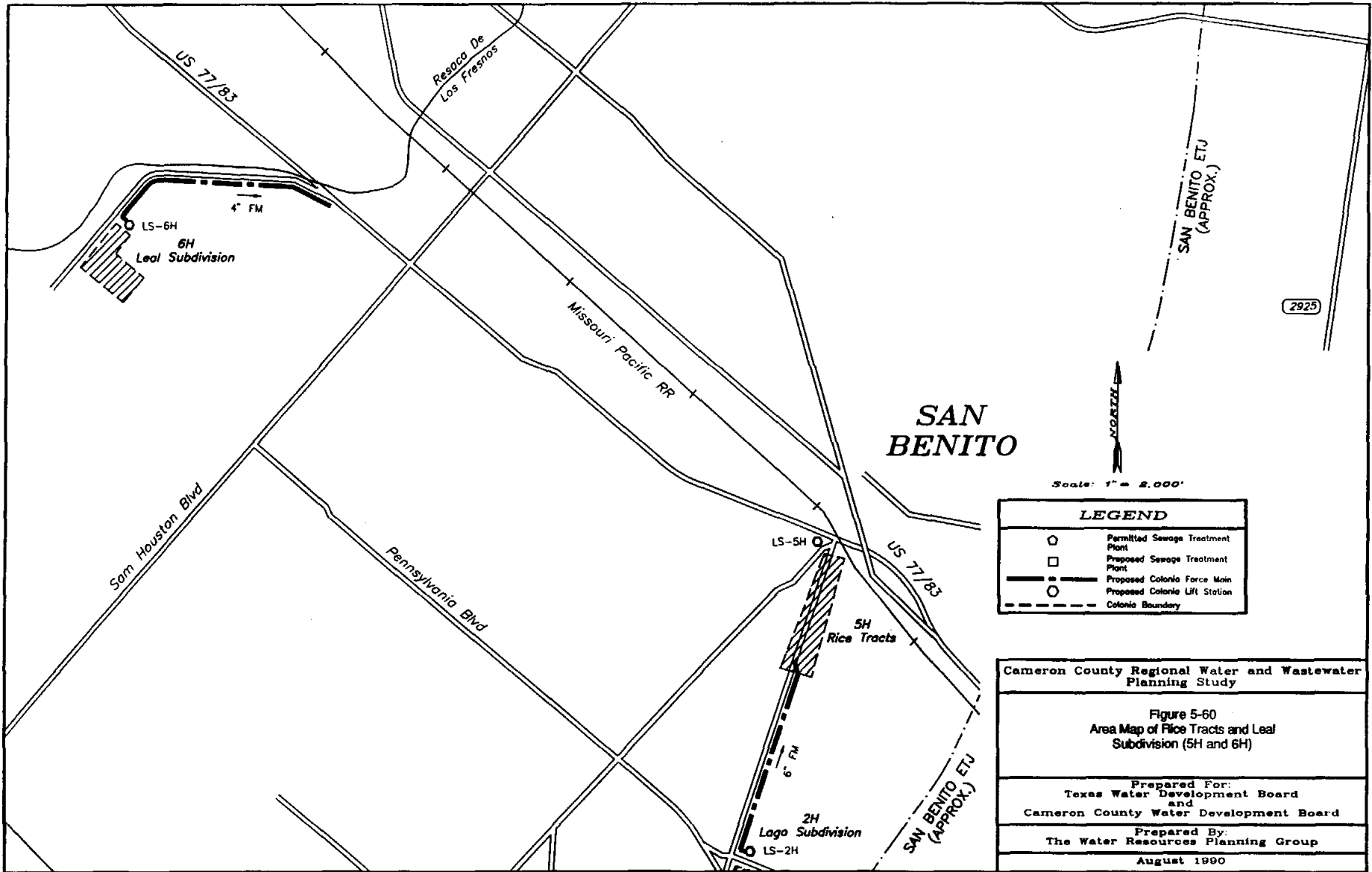

**Cameron County Regional Water and Wastewater Planning Study**

**Figure 5-60**  
**Area Map of Rice Tracts and Leal Subdivision (5H and 6H)**

**Prepared For:**  
 Texas Water Development Board  
 and  
 Cameron County Water Development Board

**Prepared By:**  
 The Water Resources Planning Group

**August 1990**

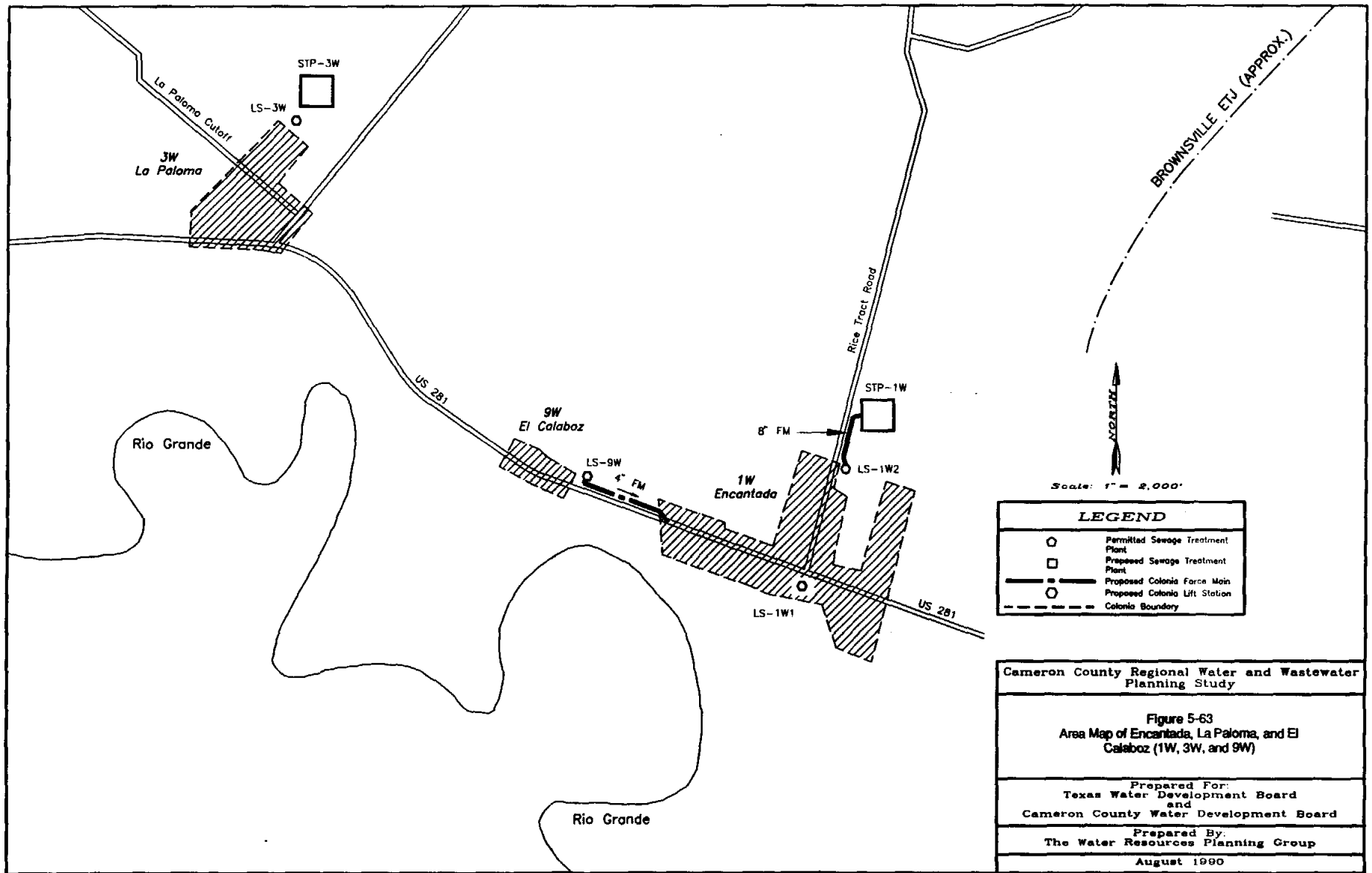

Cameron County Regional Water and Wastewater Planning Study

Figure 5-63  
Area Map of Encantada, La Paloma, and El Calaboz (1W, 3W, and 9W)

Prepared For:  
Texas Water Development Board  
and  
Cameron County Water Development Board

Prepared By:  
The Water Resources Planning Group

August 1990

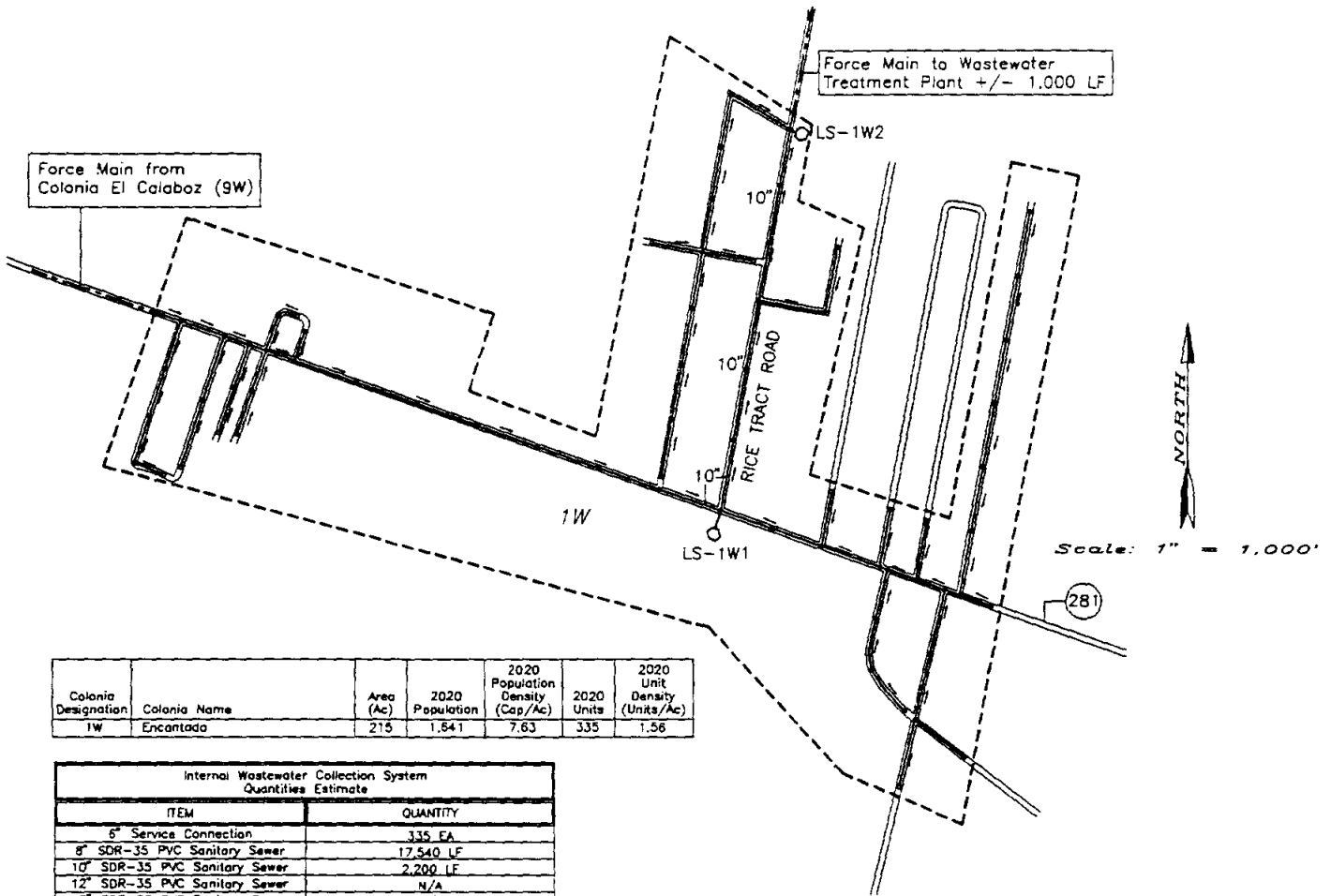

Colonia Designation	Colonia Name	Area (Ac)	2020 Population	2020 Population Density (Cap/Ac)	2020 Units	2020 Unit Density (Units/Ac)
1W	Encantada	215	1,641	7.63	335	1.56

Internal Wastewater Collection System Quantities Estimate	
ITEM	QUANTITY
6" Service Connection	335 EA
8" SDR-35 PVC Sanitary Sewer	17,540 LF
10" SDR-35 PVC Sanitary Sewer	2,200 LF
12" SDR-35 PVC Sanitary Sewer	N/A
15" SDR-35 PVC Sanitary Sewer	N/A
18" SDR-35 PVC Sanitary Sewer	N/A
Clean Out	18 EA
Manhole	50 EA
4" PVC Force Main	N/A
6" PVC Force Main	150 LF
8" PVC Force Main	1,000 LF
10" PVC Force Main	N/A
12" PVC Force Main	N/A
LS-1W1 425 GPM (3.5 HP)	1 EA
LS-1W2 580 GPM (5.5 HP)	1 EA
<b>TOTAL ESTIMATED COST</b>	<b>\$ 1,269,600</b>

**Cameron County Regional Water and Wastewater Planning Study**

**Figure 5-64  
Site Map of Encantada (1W)**

**Prepared For:  
Texas Water Development Board  
and Cameron County Water Development Board**

**Prepared By:  
The Water Resources Planning Group**

**August 1990**

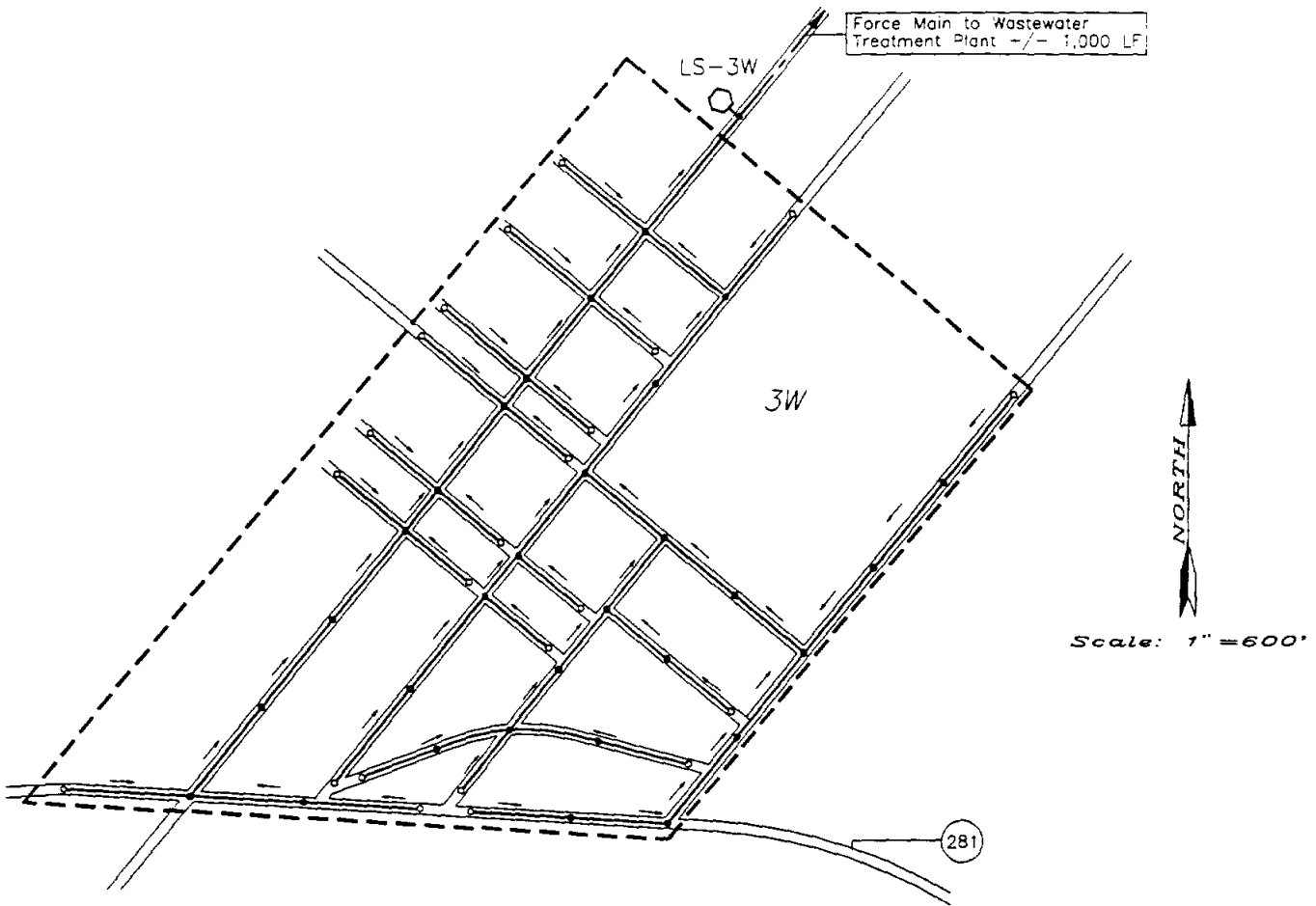

Colonia Designation	Colonia Name	Area (Ac)	2020 Population	2020 Population Density (Cap/Ac)	2020 Units	2020 Unit Density (Units/Ac)
3W	La Paloma	71	861	12.13	176	2.48

Internal Wastewater Collection System Quantities Estimate	
ITEM	QUANTITY
6" Service Connection	176 EA
8" SDR-35 PVC Sanitary Sewer	15,650 LF
10" SDR-35 PVC Sanitary Sewer	N/A
12" SDR-35 PVC Sanitary Sewer	N/A
15" SDR-35 PVC Sanitary Sewer	N/A
18" SDR-35 PVC Sanitary Sewer	N/A
Clean Out	23 EA
Manhole	32 EA
4" PVC Force Main	N/A
6" PVC Force Main	1,000 LF
8" PVC Force Main	N/A
10" PVC Force Main	N/A
12" PVC Force Main	N/A
LS-3W 250 GPM (2.5HP)	1 EA
<b>TOTAL ESTIMATED COST</b>	<b>\$ 760,094</b>

**Cameron County Regional Water and Wastewater Planning Study**

**Figure 5-65  
Site Map of La Paloma (3W)**

**Prepared For:  
Texas Water Development Board  
and Cameron County Water Development Board**

**Prepared By:  
The Water Resources Planning Group**

**August 1990**

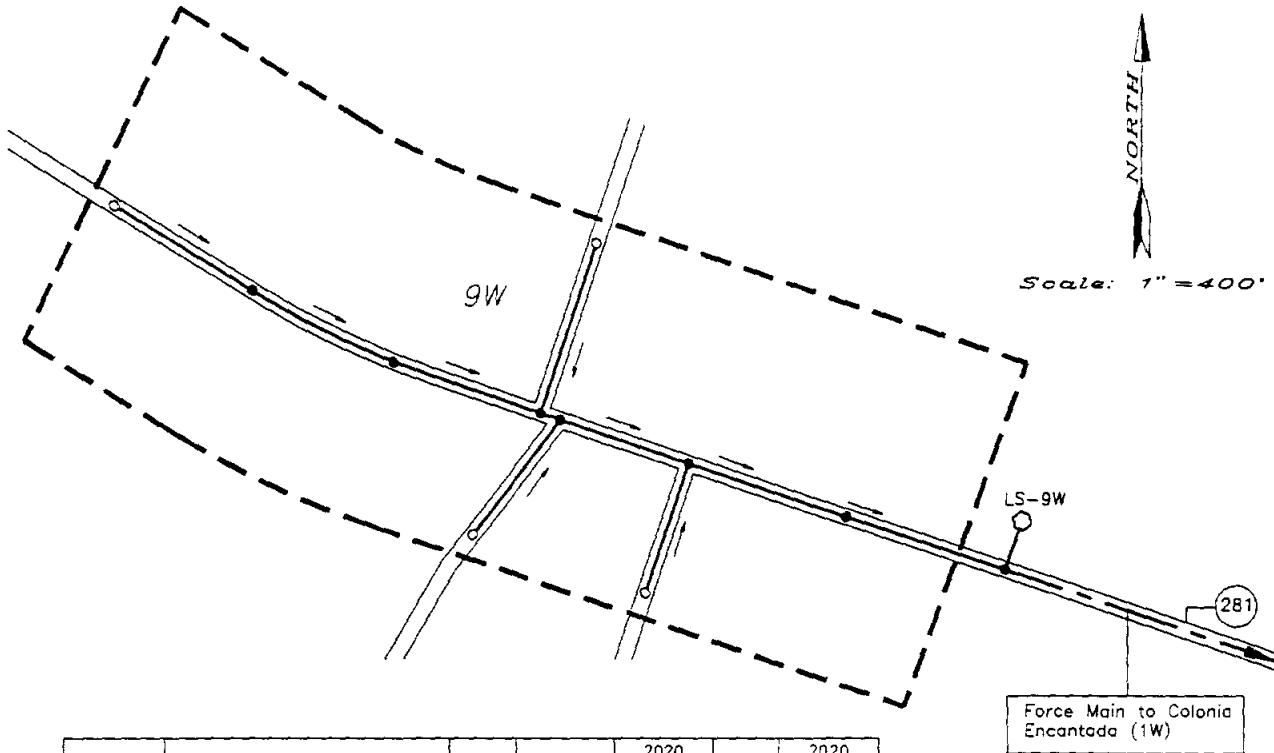

Colonia Designation	Colonia Name	Area (Ac)	2020 Population	2020 Population Density (Cap/Ac)	2020 Units	2020 Unit Density (Units/Ac)
9W	El Calaboz	23	360	16.65	73	3.17

Internal Wastewater Collection System Quantities Estimate	
ITEM	QUANTITY
6" Service Connection	73 EA
8" SDR-35 PVC Sanitary Sewer	3,100 LF
10" SDR-35 PVC Sanitary Sewer	N/A
12" SDR-35 PVC Sanitary Sewer	N/A
15" SDR-35 PVC Sanitary Sewer	N/A
18" SDR-35 PVC Sanitary Sewer	N/A
Clean Out	4 EA
Manhole	7 EA
4" PVC Force Main	4,000 LF
6" PVC Force Main	N/A
8" PVC Force Main	N/A
10" PVC Force Main	N/A
12" PVC Force Main	N/A
LS-9W 115 GPM (2.5HP)	1 EA
<b>TOTAL ESTIMATED COST</b>	<b>\$ 322,578</b>

**Cameron County Regional Water and Wastewater Planning Study**

**Figure 5-66  
Site Map of El Calaboz (9W)**

**Prepared For:  
Texas Water Development Board  
and Cameron County Water Development Board**

**Prepared By:  
The Water Resources Planning Group**

**August 1990**

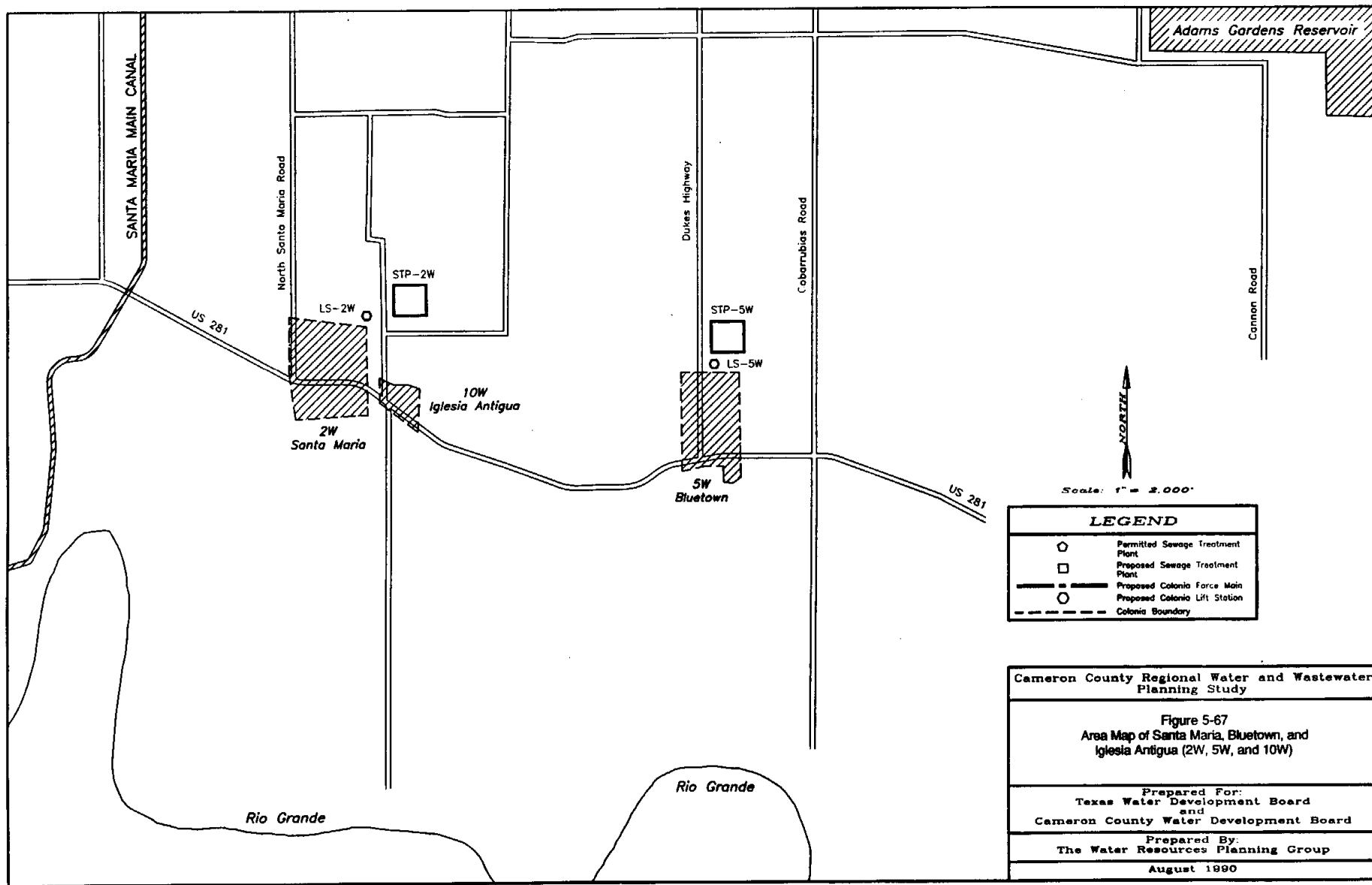

Scale: 1" = 2,000'

NORTH

LEGEND	
	Permitted Sewage Treatment Plant
	Proposed Sewage Treatment Plant
	Proposed Colonia Force Main
	Proposed Colonia Lift Station
	Colonia Boundary

Cameron County Regional Water and Wastewater Planning Study

Figure 5-67  
Area Map of Santa Maria, Bluetown, and Iglesia Antigua (2W, 5W, and 10W)

Prepared For:  
Texas Water Development Board  
and  
Cameron County Water Development Board

Prepared By:  
The Water Resources Planning Group

August 1990

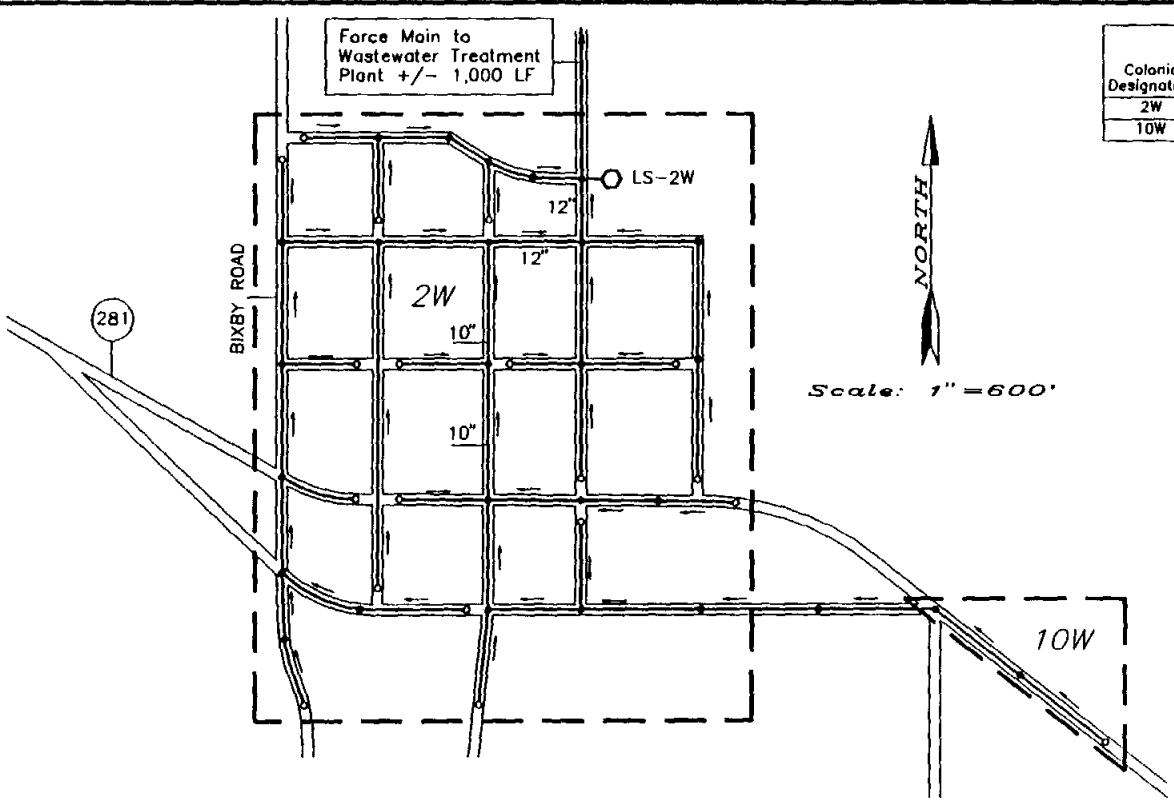

Colonia Designation	Colonia Name	Area (Ac)	2020 Population	2020 Population Density (Cap./Ac)	2020 Units	2020 Unit Density (Units/Ac)
2W	Santa Maria	80	2,306	28.83	471	5.89
10W	Iglesia Antigua	10	206	20.60	42	4.20

2W

Internal Wastewater Collection System Quantities Estimate	
ITEM	QUANTITY
6" Service Connection	471 EA
8" SDR-35 PVC Sanitary Sewer	11,250 LF
10" SDR-35 PVC Sanitary Sewer	800 LF
12" SDR-35 PVC Sanitary Sewer	950 LF
15" SDR-35 PVC Sanitary Sewer	N/A
18" SDR-35 PVC Sanitary Sewer	N/A
Clean Out	18 EA
Manhole	26 EA
4" PVC Force Main	N/A
6" PVC Force Main	N/A
8" PVC Force Main	N/A
10" PVC Force Main	1,000 LF
12" PVC Force Main	N/A
LS-2W	670 GPM (5.5 HP) 1 EA
<b>TOTAL ESTIMATED COST</b>	<b>\$ 970,279</b>

10W

Internal Wastewater Collection System Quantities Estimate	
ITEM	QUANTITY
6" Service Connection	42 EA
8" SDR-35 PVC Sanitary Sewer	1,300 LF
10" SDR-35 PVC Sanitary Sewer	N/A
12" SDR-35 PVC Sanitary Sewer	N/A
15" SDR-35 PVC Sanitary Sewer	N/A
18" SDR-35 PVC Sanitary Sewer	N/A
Clean Out	1 EA
Manhole	3 EA
4" PVC Force Main	N/A
6" PVC Force Main	N/A
8" PVC Force Main	N/A
10" PVC Force Main	N/A
12" PVC Force Main	N/A
<b>TOTAL ESTIMATED COST</b>	<b>\$ 69,478</b>

**Cameron County Regional Water and Wastewater Planning Study**

**Figure 5-68**  
**Site Map of Santa Maria and Iglesia Antigua (2W and 10W)**

**Prepared For:**  
**Texas Water Development Board**  
**and Cameron County Water Development Board**

**Prepared By:**  
**The Water Resources Planning Group**

**August 1990**



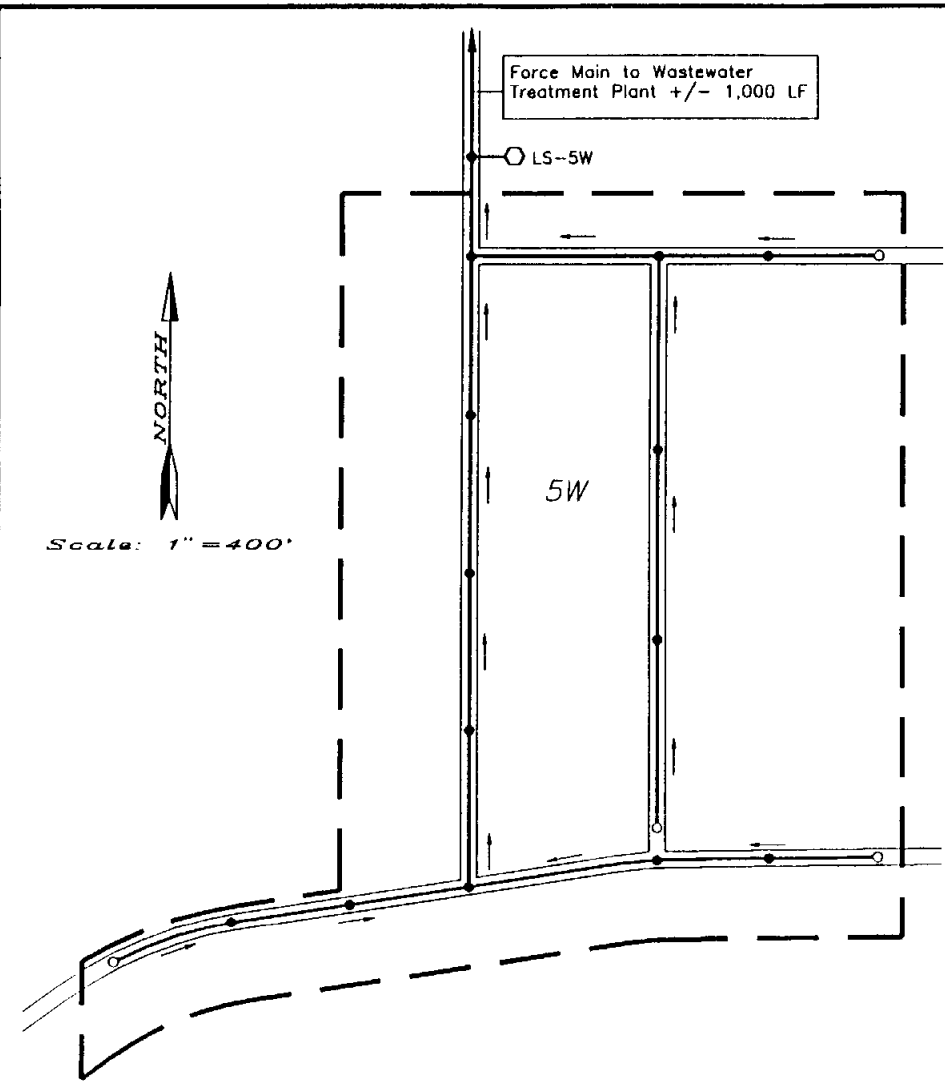

Colonia Designation	Colonia Name	Area (Ac)	2020 Population	2020 Population Density (Cap/Ac)	2020 Units	2020 Unit Density (Units/Ac)
5W	Bluetown	59	580	9.83	118	2.00

Internal Wastewater Collection System Quantities Estimate	
ITEM	QUANTITY
6" Service Connection	118 EA
8" SDR-35 PVC Sanitary Sewer	5,500 LF
10" SDR-35 PVC Sanitary Sewer	N/A
12" SDR-35 PVC Sanitary Sewer	N/A
15" SDR-35 PVC Sanitary Sewer	N/A
18" SDR-35 PVC Sanitary Sewer	N/A
Clean Out	4 EA
Manhole	14 EA
4" PVC Force Main	N/A
6" PVC Force Main	1,000 LF
8" PVC Force Main	N/A
10" PVC Force Main	N/A
12" PVC Force Main	N/A
LS-5W 170 GPM (1.5HP)	1 EA
<b>TOTAL ESTIMATED COST</b>	<b>\$ 367,166</b>

Cameron County Regional Water and Wastewater Planning Study

Figure 5-69  
Site Map of Bluetown (5W)

Prepared For:  
Texas Water Development Board  
and Cameron County Water Development Board

Prepared By:  
The Water Resources Planning Group

August 1990

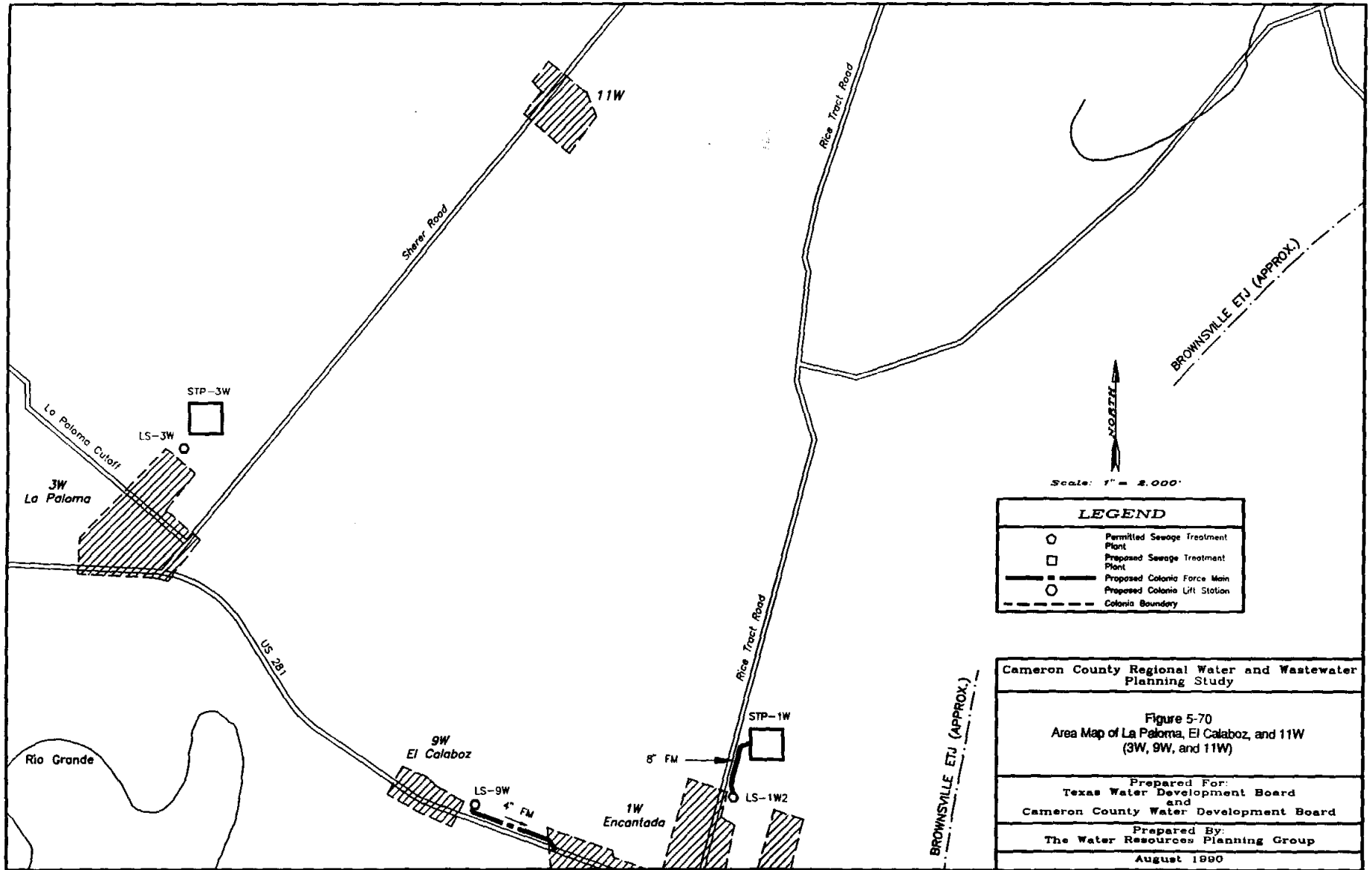

Scale: 1" = 2,000'

LEGEND	
○	Permitted Sewage Treatment Plant
□	Proposed Sewage Treatment Plant
—	Proposed Colonia Force Main
○	Proposed Colonia Lift Station
- - -	Colonia Boundary

Cameron County Regional Water and Wastewater Planning Study

Figure 5-70  
Area Map of La Paloma, El Calaboz, and 11W (3W, 9W, and 11W)

Prepared For:  
Texas Water Development Board  
and  
Cameron County Water Development Board

Prepared By:  
The Water Resources Planning Group

August 1990

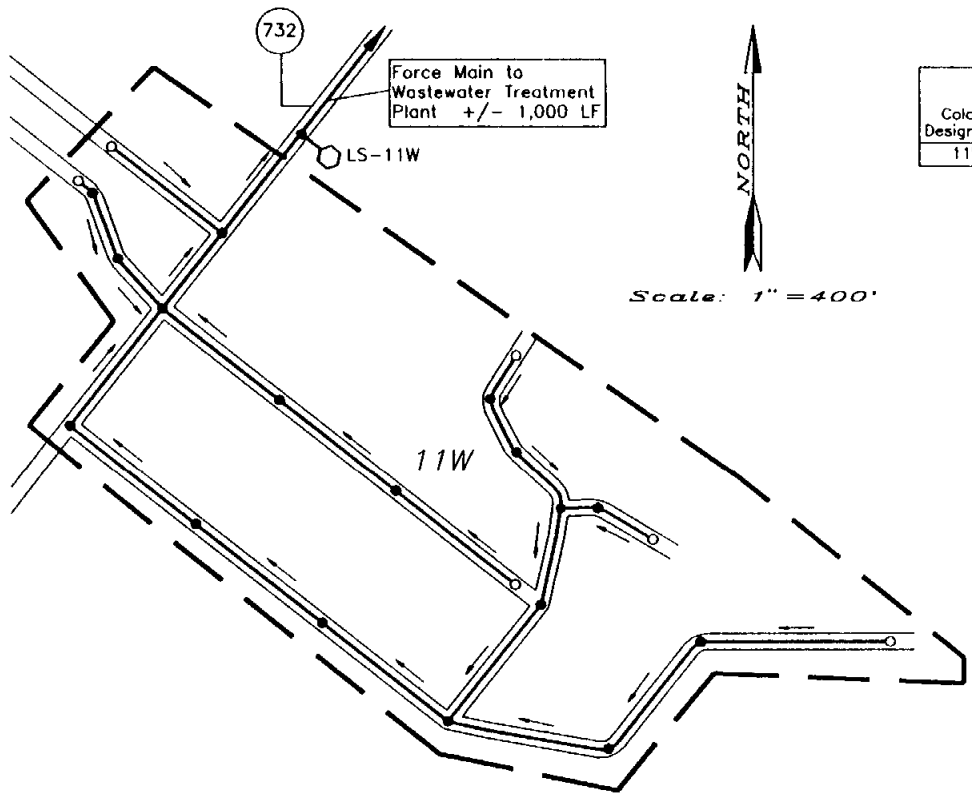

Colonia Designation	Colonia Name	Area (Ac)	2020 Population	2020 Population Density (Cap/Ac)	2020 Units	2020 Unit Density (Units/Ac)
11W	Palmer	32	285	8.91	58	1.81

Internal Wastewater Collection System Quantities Estimate	
ITEM	QUANTITY
6" Service Connection	58 EA
8" SDR-35 PVC Sanitary Sewer	5,775 LF
10" SDR-35 PVC Sanitary Sewer	N/A
12" SDR-35 PVC Sanitary Sewer	N/A
15" SDR-35 PVC Sanitary Sewer	N/A
18" SDR-35 PVC Sanitary Sewer	N/A
Clean Out	7 EA
Manhole	18 EA
4" PVC Force Main	1,000 LF
6" PVC Force Main	N/A
8" PVC Force Main	N/A
10" PVC Force Main	N/A
12" PVC Force Main	N/A
LS-11W 85 GPM (1.0 HP)	1 EA
<b>TOTAL ESTIMATED COST</b>	<b>\$ 314,769</b>

**Cameron County Regional Water and Wastewater Planning Study**

**Figure 5-71  
Site Map of 11W**

**Prepared For:  
Texas Water Development Board  
and Cameron County Water Development Board**

**Prepared By:  
The Water Resources Planning Group**

**August 1990**

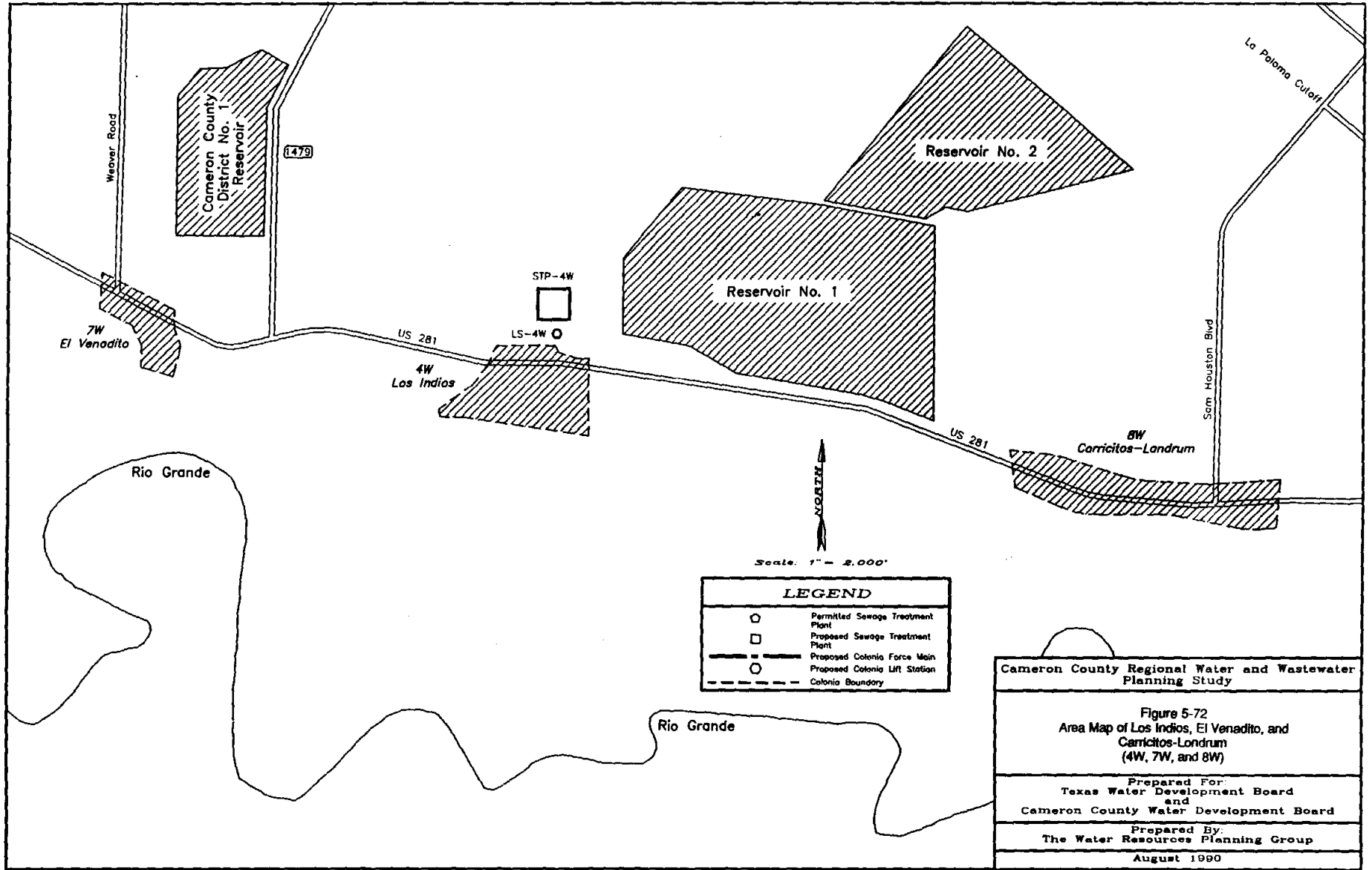

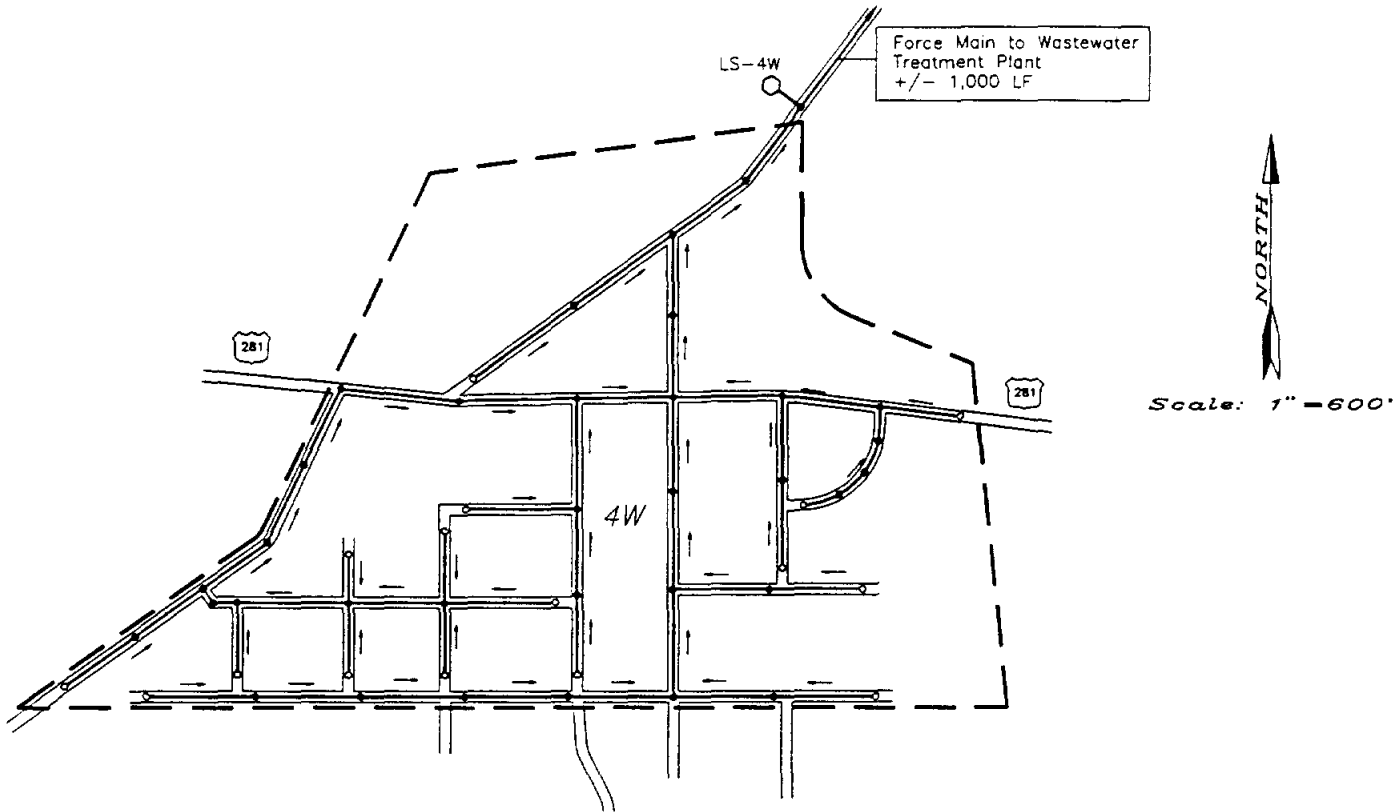

Colonia Designation	Colonia Name	Area (Ac)	2020 Population	2020 Population Density (Cap./Ac)	2020 Units	2020 Unit Density (Units/Ac)
4W	Los Indios	100	699	6.99	143	1.43

Internal Wastewater Collection System Quantities Estimate	
ITEM	QUANTITY
6" Service Connection	143 EA
8" SDR-35 PVC Sanitary Sewer	13,850 LF
10" SDR-35 PVC Sanitary Sewer	N/A
12" SDR-35 PVC Sanitary Sewer	N/A
15" SDR-35 PVC Sanitary Sewer	N/A
18" SDR-35 PVC Sanitary Sewer	N/A
Clean Out	16 EA
Manhole	34 EA
4" PVC Force Main	N/A
6" PVC Force Main	1,000 LF
8" PVC Force Main	N/A
10" PVC Force Main	N/A
12" PVC Force Main	N/A
LS-4W 205 GPM (2.0HP)	1 EA
<b>TOTAL ESTIMATED COST</b>	<b>\$ 674,211</b>

**Cameron County Regional Water and Wastewater Planning Study**  
**Figure 5-73**  
**Site Map of Los Indios (4W)**  
 Prepared For:  
**Texas Water Development Board**  
**and Cameron County Water Development Board**  
 Prepared By:  
**The Water Resources Planning Group**  
**August 1990**

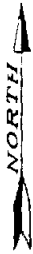

Scale: 1" = 600'

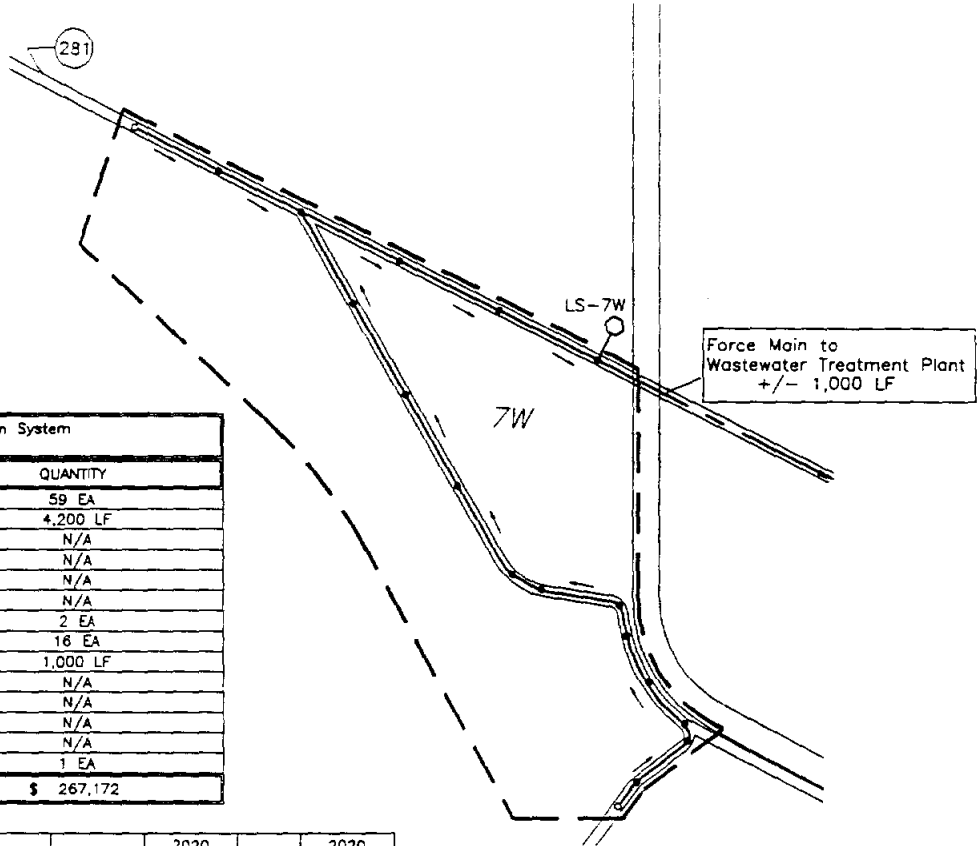

Internal Wastewater Collection System Quantities Estimate	
ITEM	QUANTITY
6" Service Connection	59 EA
8" SDR-35 PVC Sanitary Sewer	4,200 LF
10" SDR-35 PVC Sanitary Sewer	N/A
12" SDR-35 PVC Sanitary Sewer	N/A
15" SDR-35 PVC Sanitary Sewer	N/A
18" SDR-35 PVC Sanitary Sewer	N/A
Clean Out	2 EA
Manhole	16 EA
4" PVC Force Main	1,000 LF
6" PVC Force Main	N/A
8" PVC Force Main	N/A
10" PVC Force Main	N/A
12" PVC Force Main	N/A
LS-7W 90 GPM (1.0 HP)	1 EA
<b>TOTAL ESTIMATED COST</b>	<b>\$ 267,172</b>

Colonia Designation	Colonia Name	Area (Ac)	2020 Population	2020 Population Density (Cap/Ac)	2020 Units	2020 Unit Density (Units/Ac)
7W	El Venadito	41	287	7.00	59	1.44

Cameron County Regional Water and Wastewater Planning Study
Figure 5-74 Site Map of El Venadito (7W)
Prepared For: Texas Water Development Board and Cameron County Water Development Board
Prepared By: The Water Resources Planning Group
August 1990

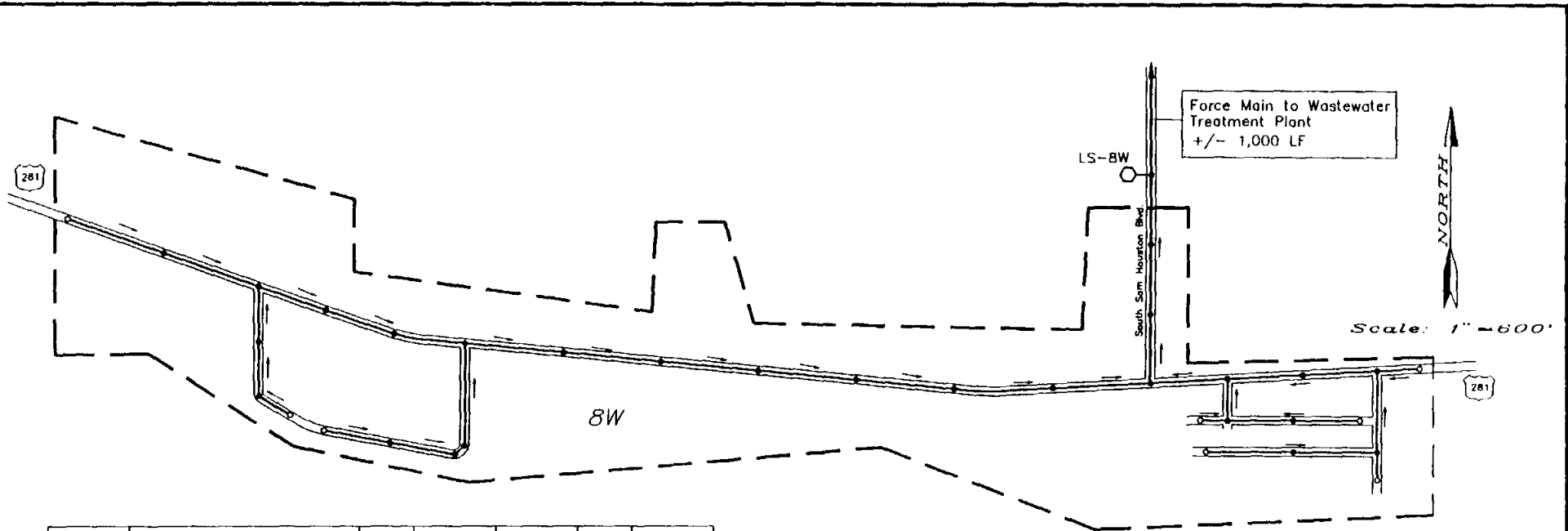

Colonia Designation	Colonia Name	Area (Ac)	2020 Population	2020 Population Density (Cap/Ac)	2020 Units	2020 Unit Density (Units/Ac)
8E	Carricitos-Landrum	116	275	2.37	56	0.48

Internal Wastewater Collection System Quantities Estimate	
ITEM	QUANTITY
6" Service Connection	56 EA
8" SDR-35 PVC Sanitary Sewer	9,325 LF
10" SDR-35 PVC Sanitary Sewer	N/A
12" SDR-35 PVC Sanitary Sewer	N/A
15" SDR-35 PVC Sanitary Sewer	N/A
18" SDR-35 PVC Sanitary Sewer	N/A
Clean Out	8 EA
Manhole	27 EA
4" PVC Force Main	1,000 LF
6" PVC Force Main	N/A
8" PVC Force Main	N/A
10" PVC Force Main	N/A
12" PVC Force Main	N/A
LS-BW 85 GPM (1.0HP)	1 EA
<b>TOTAL ESTIMATED COST</b>	<b>\$ 428,510</b>

Cameron County Regional Water and Wastewater Planning Study

Figure 5-75  
Site Map of Carricitos-Londrum (8W)

Prepared For:  
Texas Water Development Board  
and Cameron County Water Development Board

Prepared By:  
The Water Resources Planning Group

August 1990

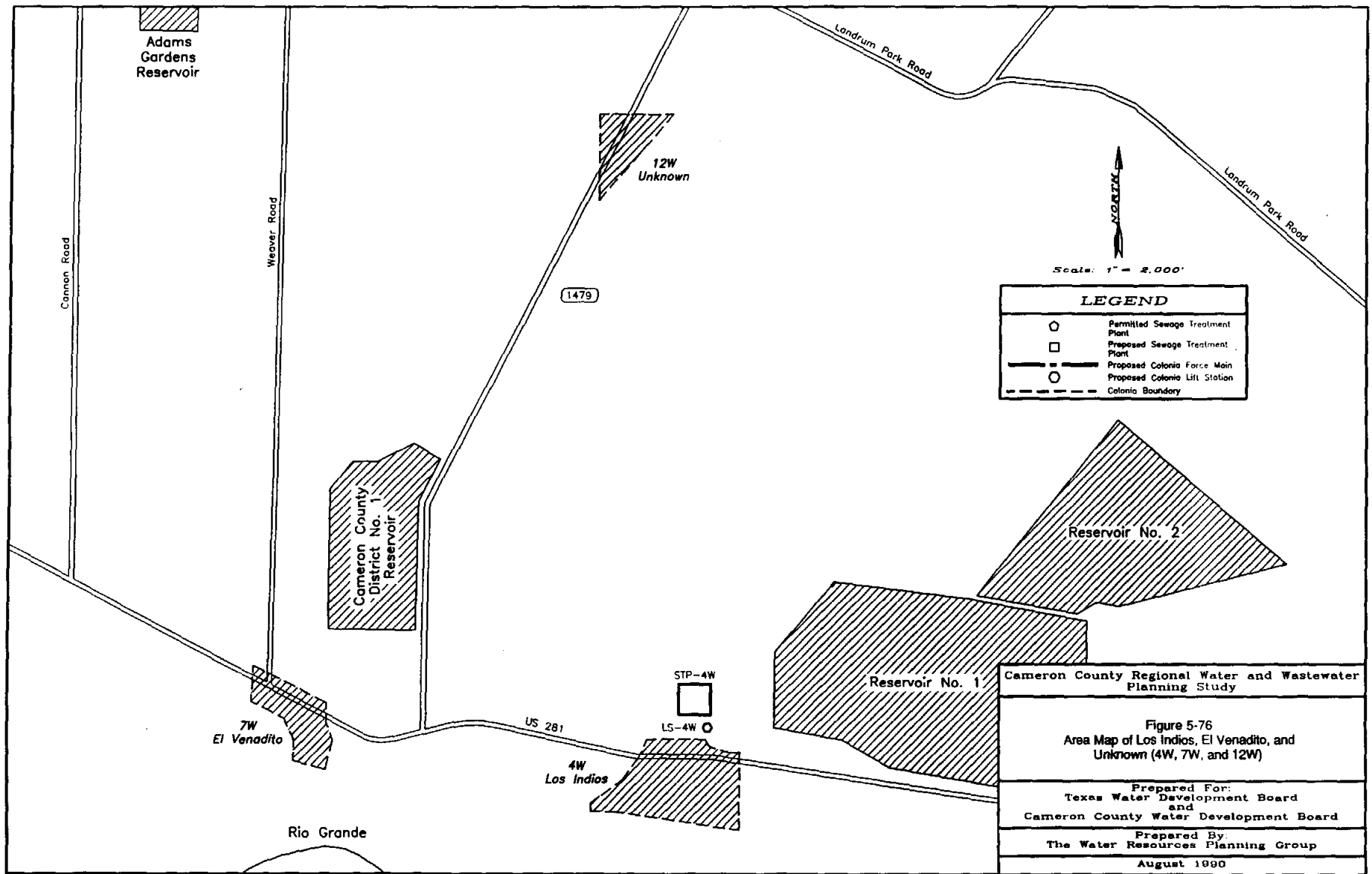



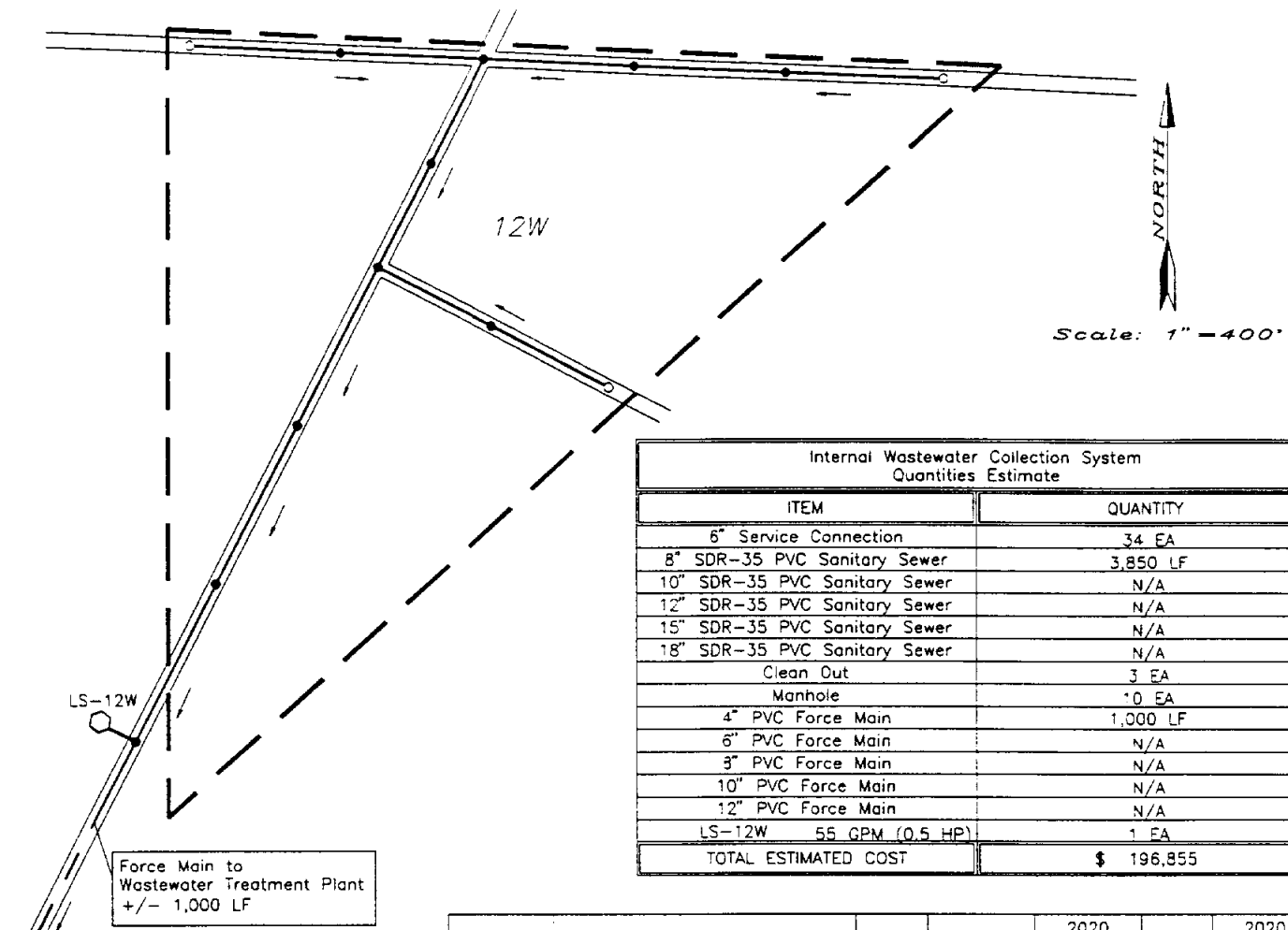

Internal Wastewater Collection System Quantities Estimate	
ITEM	QUANTITY
5" Service Connection	34 EA
8" SDR-35 PVC Sanitary Sewer	3,850 LF
10" SDR-35 PVC Sanitary Sewer	N/A
12" SDR-35 PVC Sanitary Sewer	N/A
15" SDR-35 PVC Sanitary Sewer	N/A
18" SDR-35 PVC Sanitary Sewer	N/A
Clean Out	3 EA
Manhole	10 EA
4" PVC Force Main	1,000 LF
6" PVC Force Main	N/A
3" PVC Force Main	N/A
10" PVC Force Main	N/A
12" PVC Force Main	N/A
LS-12W 55 GPM (0.5 HP)	1 EA
<b>TOTAL ESTIMATED COST</b>	<b>\$ 196,855</b>

Colonia Designation	Colonia Name	Area (Ac)	2020 Population	2020 Population Density (Cap/Ac)	2020 Units	2020 Unit Density (Units/Ac)
12W	Unknown (Mitla 2)	32	169	5.28	34	1.06

**Cameron County Regional Water and Wastewater  
Planning Study**

---

**Figure 5-77  
Site Map of Unknown (12W)**

---

**Prepared For:  
Texas Water Development Board  
and Cameron County Water Development Board**

---

**Prepared By:  
The Water Resources Planning Group**

---

**August 1990**

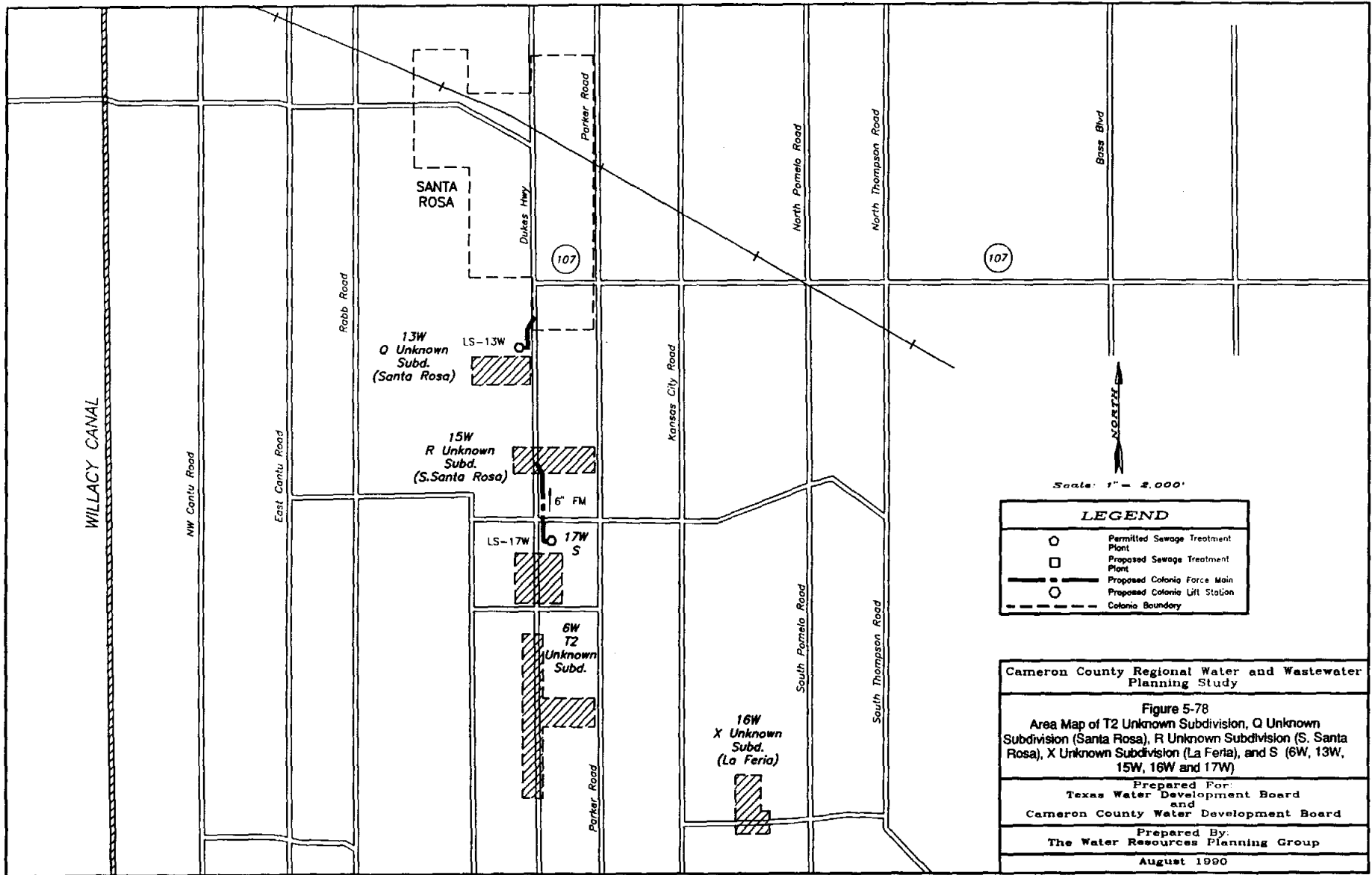

**LEGEND**

○	Permitted Sewage Treatment Plant
□	Proposed Sewage Treatment Plant
—	Proposed Colonia Force Main
○	Proposed Colonia Lift Station
- - -	Colonia Boundary

Cameron County Regional Water and Wastewater Planning Study

Figure 5-78  
Area Map of T2 Unknown Subdivision, Q Unknown Subdivision (Santa Rosa), R Unknown Subdivision (S. Santa Rosa), X Unknown Subdivision (La Feria), and S (6W, 13W, 15W, 16W and 17W)

Prepared For:  
Texas Water Development Board  
and  
Cameron County Water Development Board

Prepared By:  
The Water Resources Planning Group  
August 1990

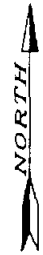
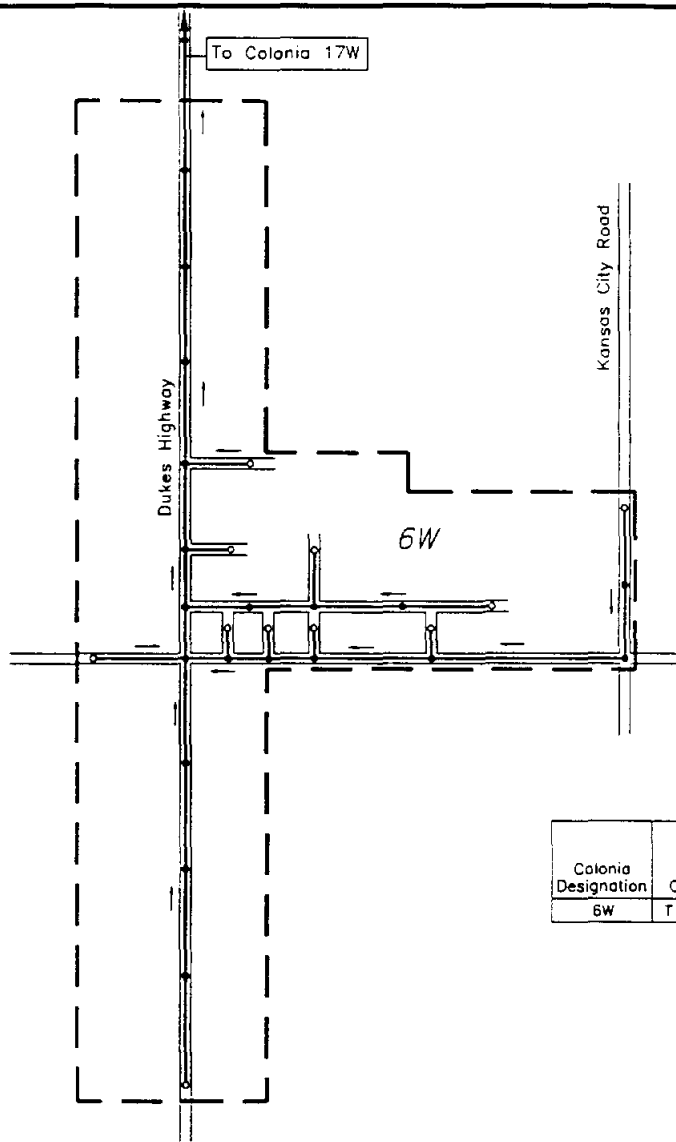

Scale: 1" = 600'

Internal Wastewater Collection System Quantities Estimate	
ITEM	QUANTITY
6" Service Connection	88 EA
8" SDR-35 PVC Sanitary Sewer	7,400 LF
10" SDR-35 PVC Sanitary Sewer	N/A
12" SDR-35 PVC Sanitary Sewer	N/A
15" SDR-35 PVC Sanitary Sewer	N/A
18" SDR-35 PVC Sanitary Sewer	N/A
Clean Out	11 EA
Manhole	20 EA
4" PVC Force Main	N/A
6" PVC Force Main	N/A
8" PVC Force Main	N/A
10" PVC Force Main	N/A
12" PVC Force Main	N/A
<b>TOTAL ESTIMATED COST</b>	<b>\$ 304,440</b>

Colonia Designation	Colonia Name	Area (Ac)	2020 Population	2020 Population Density (Cap/Ac)	2020 Units	2020 Unit Density (Units/Ac)
6W	T 2 Unknown Subdivision	45	431	9.58	88	1.96

**Cameron County Regional Water and Wastewater Planning Study**

**Figure 5-79  
Site Map of T2 Unknown Subdivision (6W)**

**Prepared For:  
Texas Water Development Board  
and Cameron County Water Development Board**

**Prepared By:  
The Water Resources Planning Group**

**August 1990**

Colonia Designation	Colonia Name	Area (Ac)	2020 Population	2020 Population Density (Pop./Ac)	2020 Units	2020 Unit Density (Units/Ac)
13W	Q Unknown Subd. (Santa Rosa)	16	241	15.06	49	3.06
15W	R Unknown Subd. (Santa Rosa)	25	196	7.84	40	1.60
17W	S	25	116	4.64	24	0.96

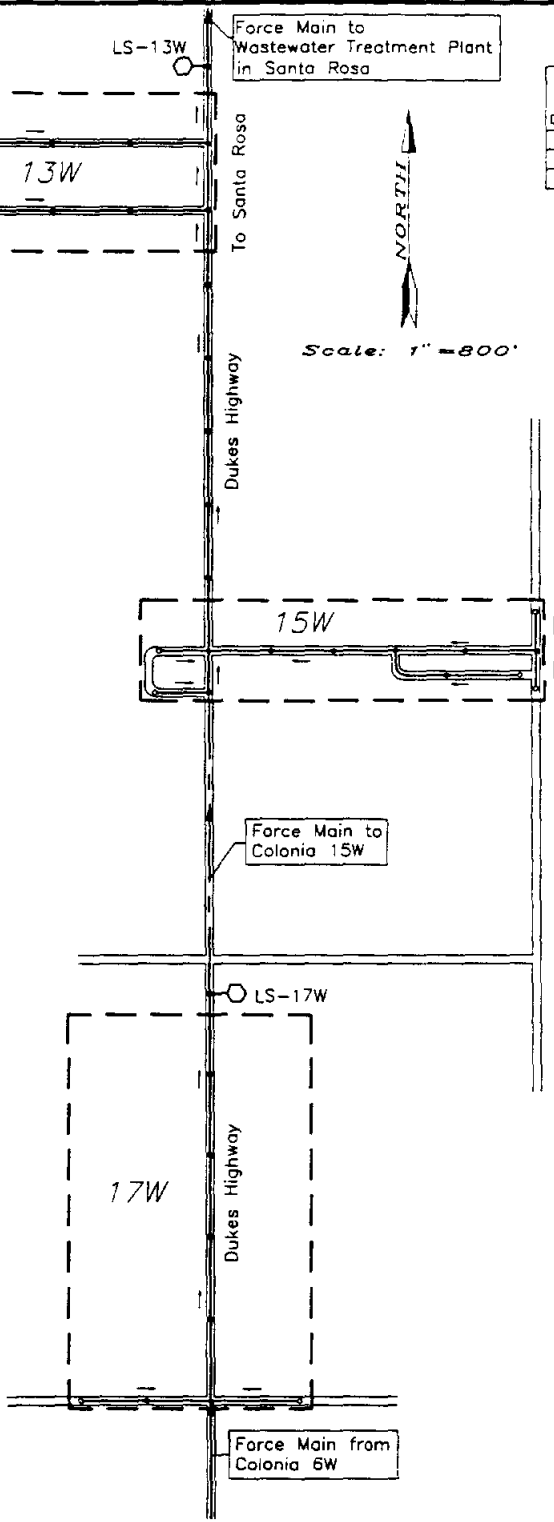

13W

Internal Wastewater Collection System Quantities Estimate	
ITEM	QUANTITY
6" Service Connection	49 EA
8" SDR-35 PVC Sanitary Sewer	4,100 LF
10" SDR-35 PVC Sanitary Sewer	N/A
12" SDR-35 PVC Sanitary Sewer	N/A
15" SDR-35 PVC Sanitary Sewer	N/A
18" SDR-35 PVC Sanitary Sewer	N/A
Clean Out	2 EA
Manhole	11 EA
4" PVC Force Main	N/A
6" PVC Force Main	N/A
8" PVC Force Main	1,500 LF
10" PVC Force Main	N/A
12" PVC Force Main	N/A
LS-13W 300 GPM (2.5 HP)	1 EA
<b>TOTAL ESTIMATED COST</b>	<b>\$ 327,048</b>

15W

Internal Wastewater Collection System Quantities Estimate	
ITEM	QUANTITY
6" Service Connection	40 EA
8" SDR-35 PVC Sanitary Sewer	3,700 LF
10" SDR-35 PVC Sanitary Sewer	N/A
12" SDR-35 PVC Sanitary Sewer	N/A
15" SDR-35 PVC Sanitary Sewer	N/A
18" SDR-35 PVC Sanitary Sewer	N/A
Clean Out	5 EA
Manhole	11 EA
4" PVC Force Main	N/A
6" PVC Force Main	N/A
8" PVC Force Main	N/A
10" PVC Force Main	N/A
12" PVC Force Main	N/A
<b>TOTAL ESTIMATED COST</b>	<b>\$ 151,685</b>

17W

Internal Wastewater Collection System Quantities Estimate	
ITEM	QUANTITY
6" Service Connection	24 EA
8" SDR-35 PVC Sanitary Sewer	3,000 LF
10" SDR-35 PVC Sanitary Sewer	N/A
12" SDR-35 PVC Sanitary Sewer	N/A
15" SDR-35 PVC Sanitary Sewer	N/A
18" SDR-35 PVC Sanitary Sewer	N/A
Clean Out	2 EA
Manhole	7 EA
4" PVC Force Main	1,400 LF
6" PVC Force Main	N/A
8" PVC Force Main	N/A
10" PVC Force Main	N/A
12" PVC Force Main	N/A
LS-17W 170 GPM (2.5 HP)	1 EA
<b>TOTAL ESTIMATED COST</b>	<b>\$ 259,230</b>

**Cameron County Regional Water and Wastewater Planning Study**

**Figure 5-80**  
 Site Map of Q Unknown Sub.(Santa Rosa), R Unknown Sub. (S. Santa Rosa), & S (13W, 15W, & 17W)

Prepared For:  
**Texas Water Development Board**  
 and **Cameron County Water Development Board**

Prepared By:  
**The Water Resources Planning Group**

August 1990

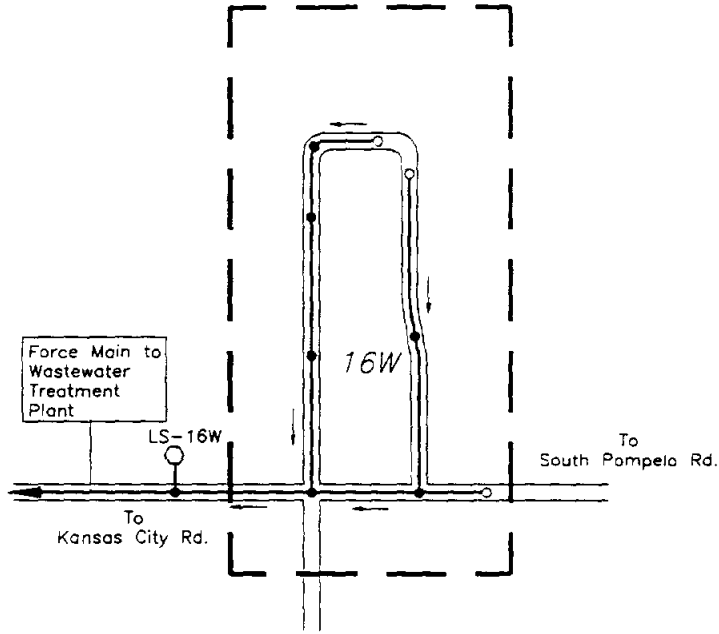

Colonia Designation	Colonia Name	Area (Ac)	2020 Population	2020 Population Density (Cap/Ac)	2020 Units	2020 Unit Density (Units/Ac)
16W	X Unknown Subd. (La Feria)	16	116	7.25	24	1.50

Internal Wastewater Collection System Quantities Estimate	
ITEM	QUANTITY
6" Service Connection	24 EA
8" SDR-35 PVC Sanitary Sewer	2,250 LF
10" SDR-35 PVC Sanitary Sewer	N/A
12" SDR-35 PVC Sanitary Sewer	N/A
15" SDR-35 PVC Sanitary Sewer	N/A
18" SDR-35 PVC Sanitary Sewer	N/A
Clean Out	3 EA
Manhole	7 EA
4" PVC Force Main	1,000 LF
6" PVC Force Main	N/A
8" PVC Force Main	N/A
10" PVC Force Main	N/A
12" PVC Force Main	N/A
LS-16W 35 GPM (0.5 HP)	1 EA
<b>TOTAL ESTIMATED COST</b>	<b>\$ 141,000</b>

Cameron County Regional Water and Wastewater Planning Study

Figure 5-81  
Site Map of X Unknown Subdivision (La Feria) (16W)

Prepared For:  
Texas Water Development Board  
and Cameron County Water Development Board

Prepared By:  
The Water Resources Planning Group

August 1990

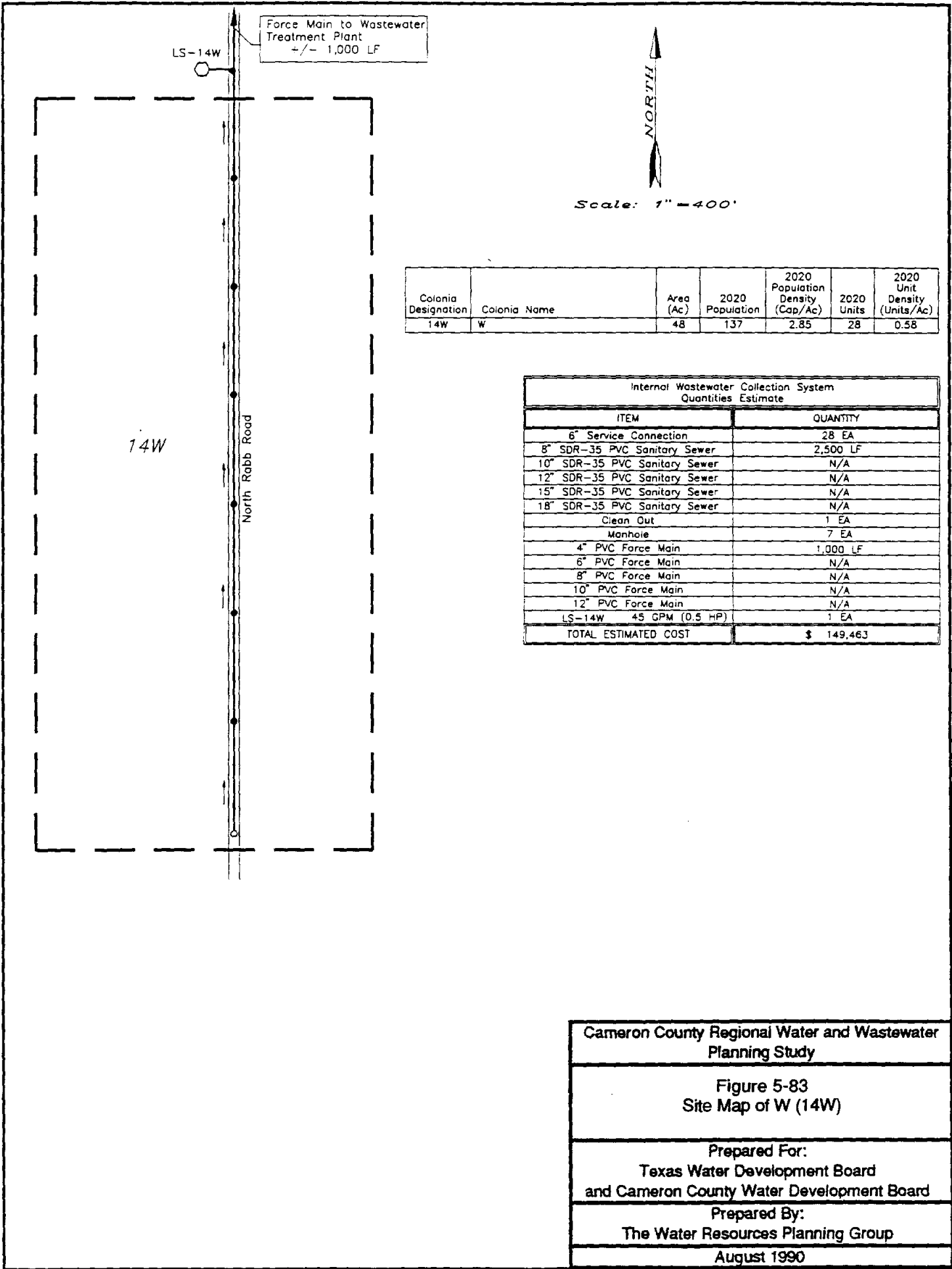

Colonia Designation	Colonia Name	Area (Ac)	2020 Population	2020 Population Density (Cap/Ac)	2020 Units	2020 Unit Density (Units/Ac)
14W	W	48	137	2.85	28	0.58

Internal Wastewater Collection System Quantities Estimate	
ITEM	QUANTITY
6" Service Connection	28 EA
8" SDR-35 PVC Sanitary Sewer	2,500 LF
10" SDR-35 PVC Sanitary Sewer	N/A
12" SDR-35 PVC Sanitary Sewer	N/A
15" SDR-35 PVC Sanitary Sewer	N/A
18" SDR-35 PVC Sanitary Sewer	N/A
Clean Out	1 EA
Manhole	7 EA
4" PVC Force Main	1,000 LF
6" PVC Force Main	N/A
8" PVC Force Main	N/A
10" PVC Force Main	N/A
12" PVC Force Main	N/A
LS-14W 45 GPM (0.5 HP)	1 EA
<b>TOTAL ESTIMATED COST</b>	<b>\$ 149,463</b>

**Cameron County Regional Water and Wastewater Planning Study**

**Figure 5-83  
Site Map of W (14W)**

**Prepared For:  
Texas Water Development Board  
and Cameron County Water Development Board**

**Prepared By:  
The Water Resources Planning Group**

**August 1990**

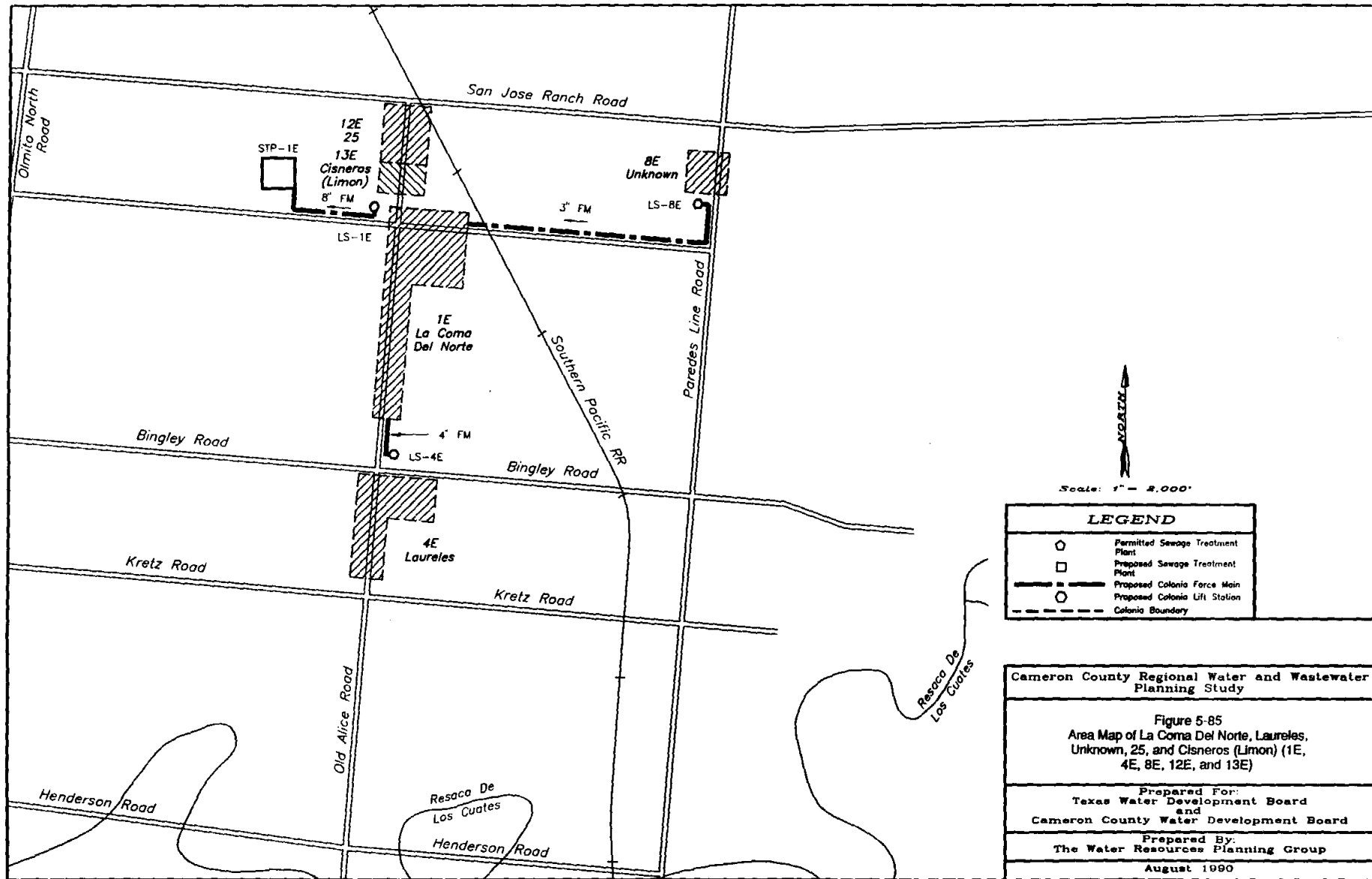

Scale: 1" = 8,000'

LEGEND	
○	Permitted Sewage Treatment Plant
□	Proposed Sewage Treatment Plant
—	Proposed Colonia Force Main
○	Proposed Colonia Lift Station
- - -	Colonia Boundary

Cameron County Regional Water and Wastewater Planning Study

Figure 5-85  
 Area Map of La Coma Del Norte, Laureles, Unknown, 25, and Cisneros (Limon) (1E, 4E, 8E, 12E, and 13E)

Prepared For:  
 Texas Water Development Board  
 and  
 Cameron County Water Development Board

Prepared By:  
 The Water Resources Planning Group  
 August 1990

Colonia Designation	Colonia Name	Area (Ac)	2020 Population	2020 Population Density (Cap/Ac)	2020 Units	2020 Unit Density (Units/Ac)
1E	La Coma Del Norte	100	888	8.88	177	1.77
12E	25	32	75	2.34	15	0.47
13E	Cisneros (Limon)	9	62	8.89	13	1.44

1E

Internal Wastewater Collection System Quantities Estimate	
ITEM	QUANTITY
6" Service Connection	177 EA
8" SDR-35 PVC Sanitary Sewer	10,200 LF
10" SDR-35 PVC Sanitary Sewer	400 LF
12" SDR-35 PVC Sanitary Sewer	N/A
15" SDR-35 PVC Sanitary Sewer	N/A
18" SDR-35 PVC Sanitary Sewer	N/A
Clean Out	6 EA
Manhole	28 EA
4" PVC Force Main	N/A
6" PVC Force Main	N/A
8" PVC Force Main	2,000 LF
10" PVC Force Main	N/A
12" PVC Force Main	N/A
LS-1E	480 GPM (5.0HP)
<b>TOTAL ESTIMATED COST</b>	<b>\$ 698,375</b>

12E

Internal Wastewater Collection System Quantities Estimate	
ITEM	QUANTITY
6" Service Connection	15 EA
8" SDR-35 PVC Sanitary Sewer	900 LF
10" SDR-35 PVC Sanitary Sewer	N/A
12" SDR-35 PVC Sanitary Sewer	N/A
15" SDR-35 PVC Sanitary Sewer	N/A
18" SDR-35 PVC Sanitary Sewer	N/A
Clean Out	3 EA
Manhole	5 EA
4" PVC Force Main	N/A
6" PVC Force Main	N/A
8" PVC Force Main	N/A
10" PVC Force Main	N/A
12" PVC Force Main	N/A
<b>TOTAL ESTIMATED COST</b>	<b>\$ 46,453</b>

13E

Internal Wastewater Collection System Quantities Estimate	
ITEM	QUANTITY
6" Service Connection	13 EA
8" SDR-35 PVC Sanitary Sewer	800 LF
10" SDR-35 PVC Sanitary Sewer	N/A
12" SDR-35 PVC Sanitary Sewer	N/A
15" SDR-35 PVC Sanitary Sewer	N/A
18" SDR-35 PVC Sanitary Sewer	N/A
Clean Out	N/A
Manhole	2 EA
4" PVC Force Main	N/A
6" PVC Force Main	N/A
8" PVC Force Main	N/A
10" PVC Force Main	N/A
12" PVC Force Main	N/A
<b>TOTAL ESTIMATED COST</b>	<b>\$ 29,082</b>

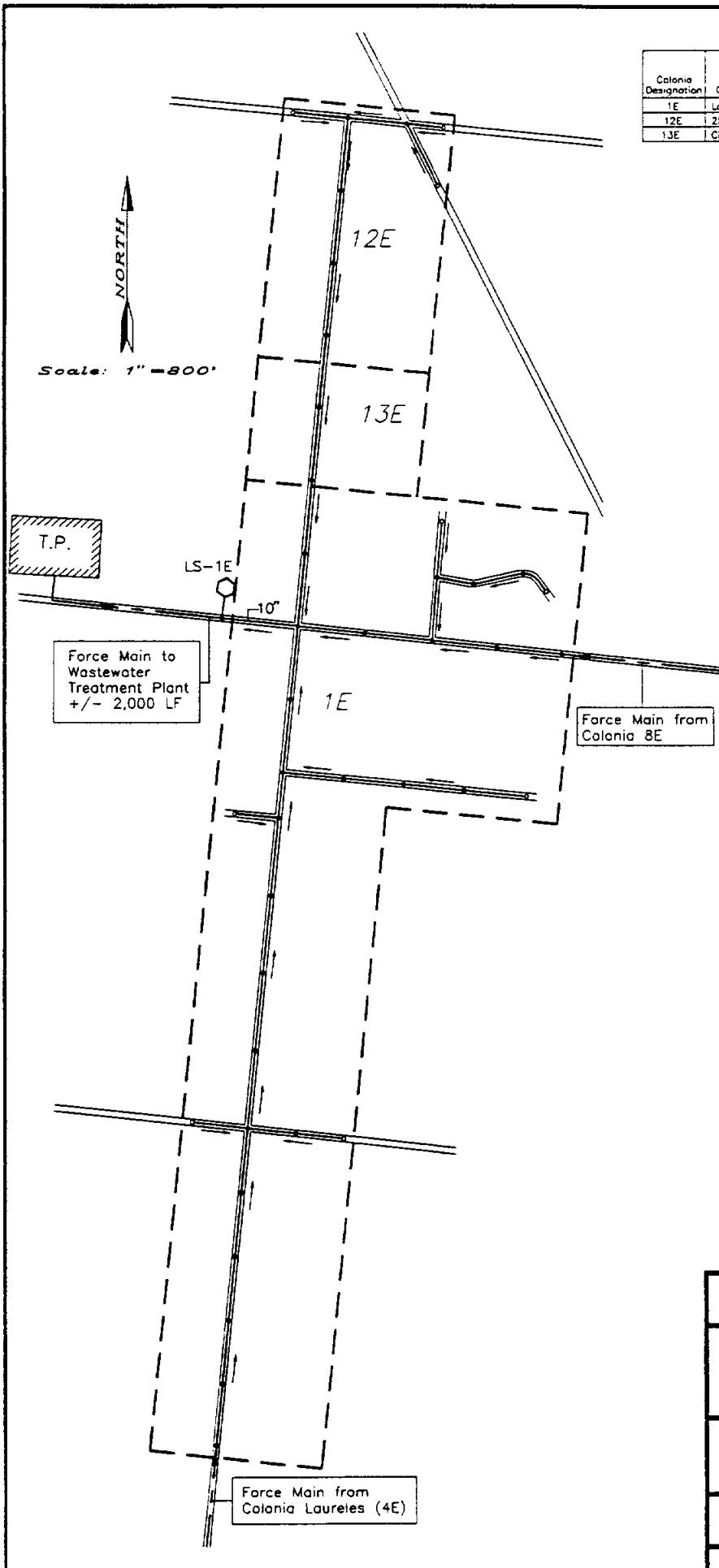

**Cameron County Regional Water and Wastewater Planning Study**

**Figure 5-86**  
**Site Map of La Coma Del Norte, 25, and**  
**Cisneros (Limon) (1E, 12E, and 13E)**

**Prepared For:**  
**Texas Water Development Board**  
**and Cameron County Water Development Board**

**Prepared By:**  
**The Water Resources Planning Group**

**August 1990**



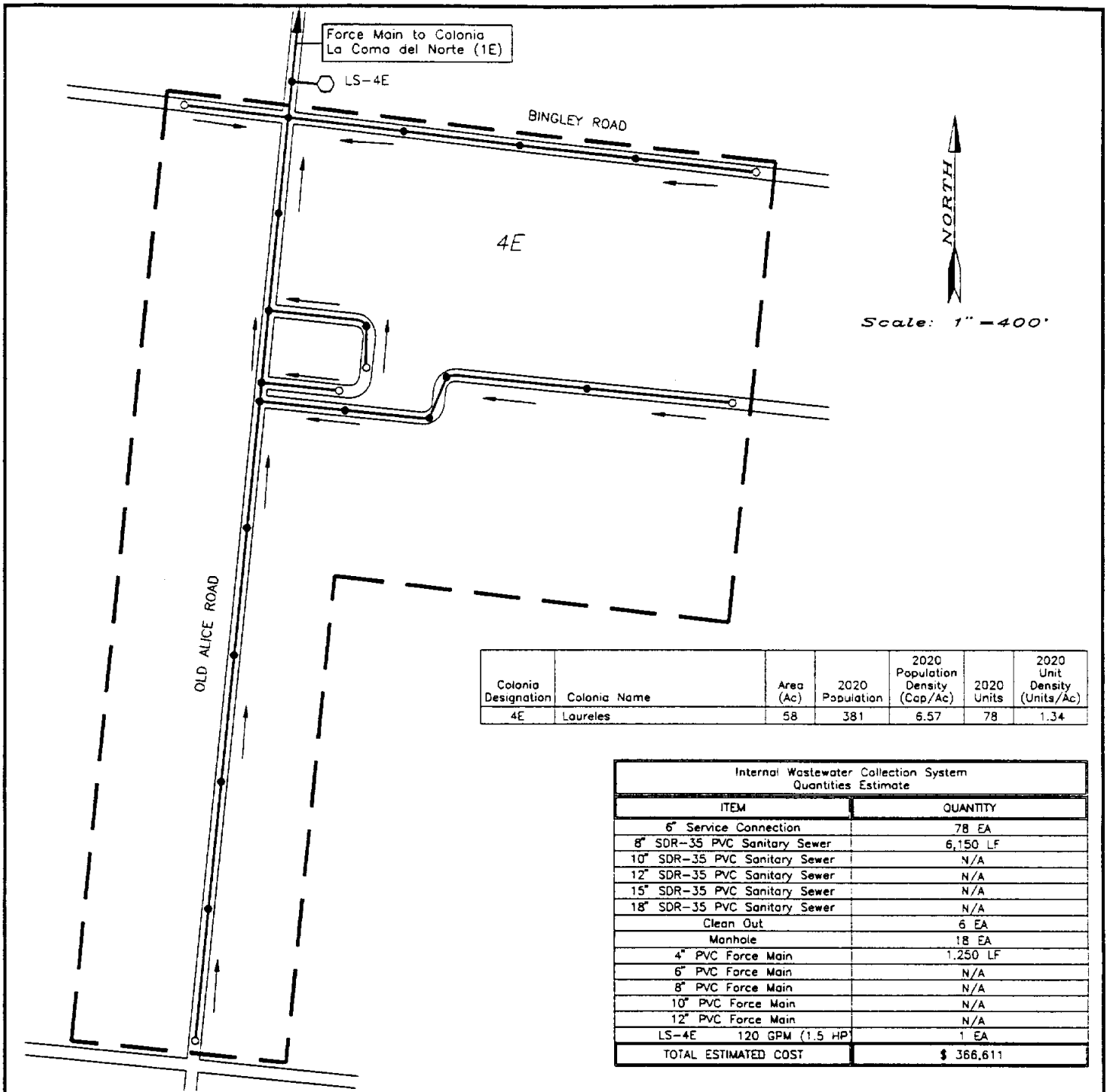

**Cameron County Regional Water and Wastewater Planning Study**

**Figure 5-87  
Site Map of Laureles (4E)**

**Prepared For:  
Texas Water Development Board  
and Cameron County Water Development Board**

**Prepared By:  
The Water Resources Planning Group**

**August 1990**

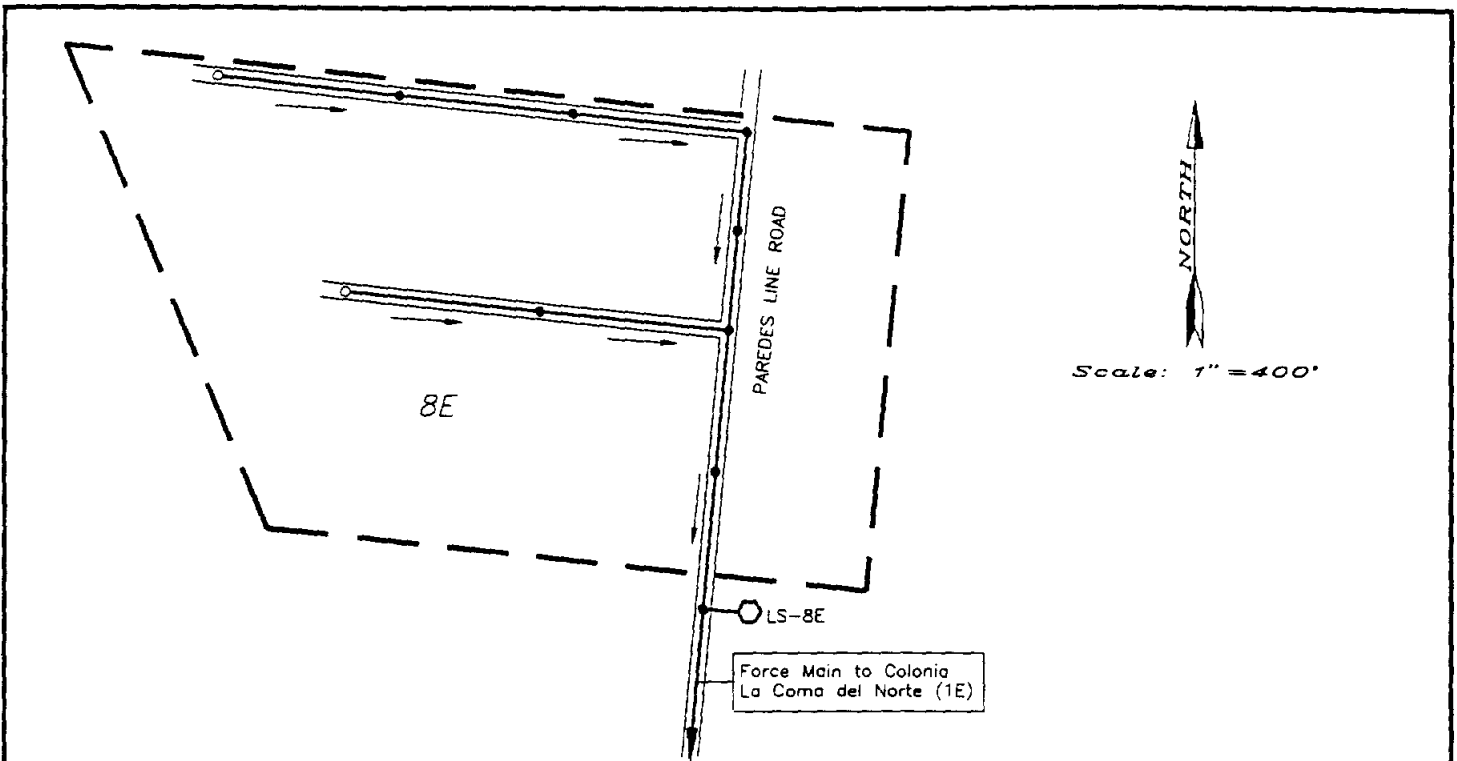

Colonia Designation	Colonia Name	Area (Ac)	2020 Population	2020 Population Density (Cap/Ac)	2020 Units	2020 Unit Density (Units/Ac)
8E	Unknown	16	262	16.38	53	3.31

Internal Wastewater Collection System Quantities Estimate	
ITEM	QUANTITY
6" Service Connection	53 EA
8" SDR-35 PVC Sanitary Sewer	2,850 LF
10" SDR-35 PVC Sanitary Sewer	N/A
12" SDR-35 PVC Sanitary Sewer	N/A
15" SDR-35 PVC Sanitary Sewer	N/A
18" SDR-35 PVC Sanitary Sewer	N/A
Clean Out	2 EA
Manhole	8 EA
3" PVC Force Main	12,000 LF
6" PVC Force Main	N/A
8" PVC Force Main	N/A
10" PVC Force Main	N/A
12" PVC Force Main	N/A
LS-8E 78 GPM (6.5 HP)	1 EA
<b>TOTAL ESTIMATED COST</b>	<b>\$ 439,811</b>

<b>Cameron County Regional Water and Wastewater Planning Study</b>
<b>Figure 5-88 Site Map of Unknown (8E)</b>
<b>Prepared For: Texas Water Development Board and Cameron County Water Development Board</b>
<b>Prepared By: The Water Resources Planning Group</b>
<b>August 1990</b>

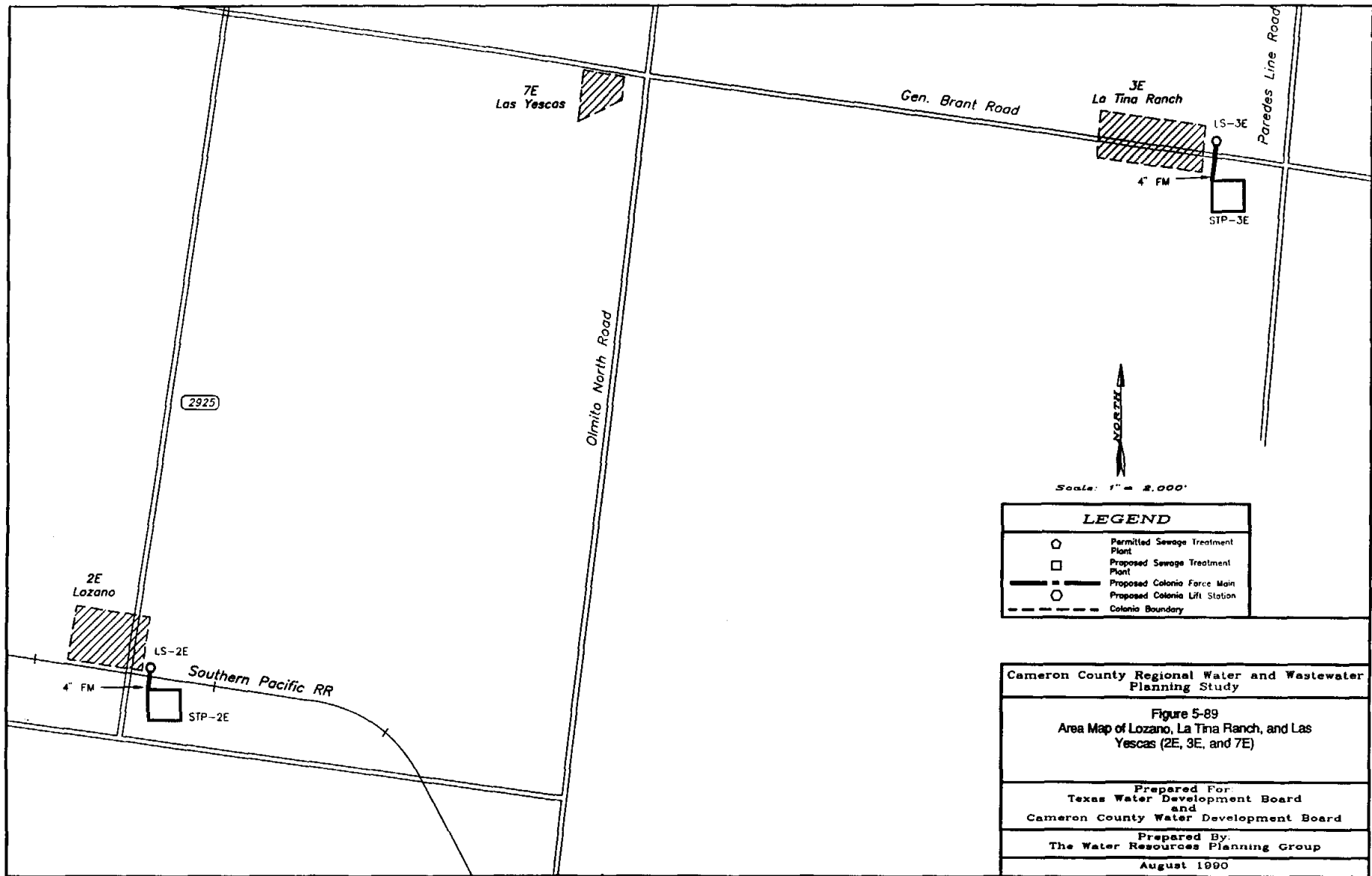

Scale: 1" = 2,000'

LEGEND	
○	Permitted Sewage Treatment Plant
□	Proposed Sewage Treatment Plant
—	Proposed Colonia Force Main
○	Proposed Colonia Lift Station
- - -	Colonia Boundary

Cameron County Regional Water and Wastewater Planning Study
Figure 5-89 Area Map of Lozano, La Tina Ranch, and Las Yescas (2E, 3E, and 7E)
Prepared For: Texas Water Development Board and Cameron County Water Development Board
Prepared By: The Water Resources Planning Group
August 1990

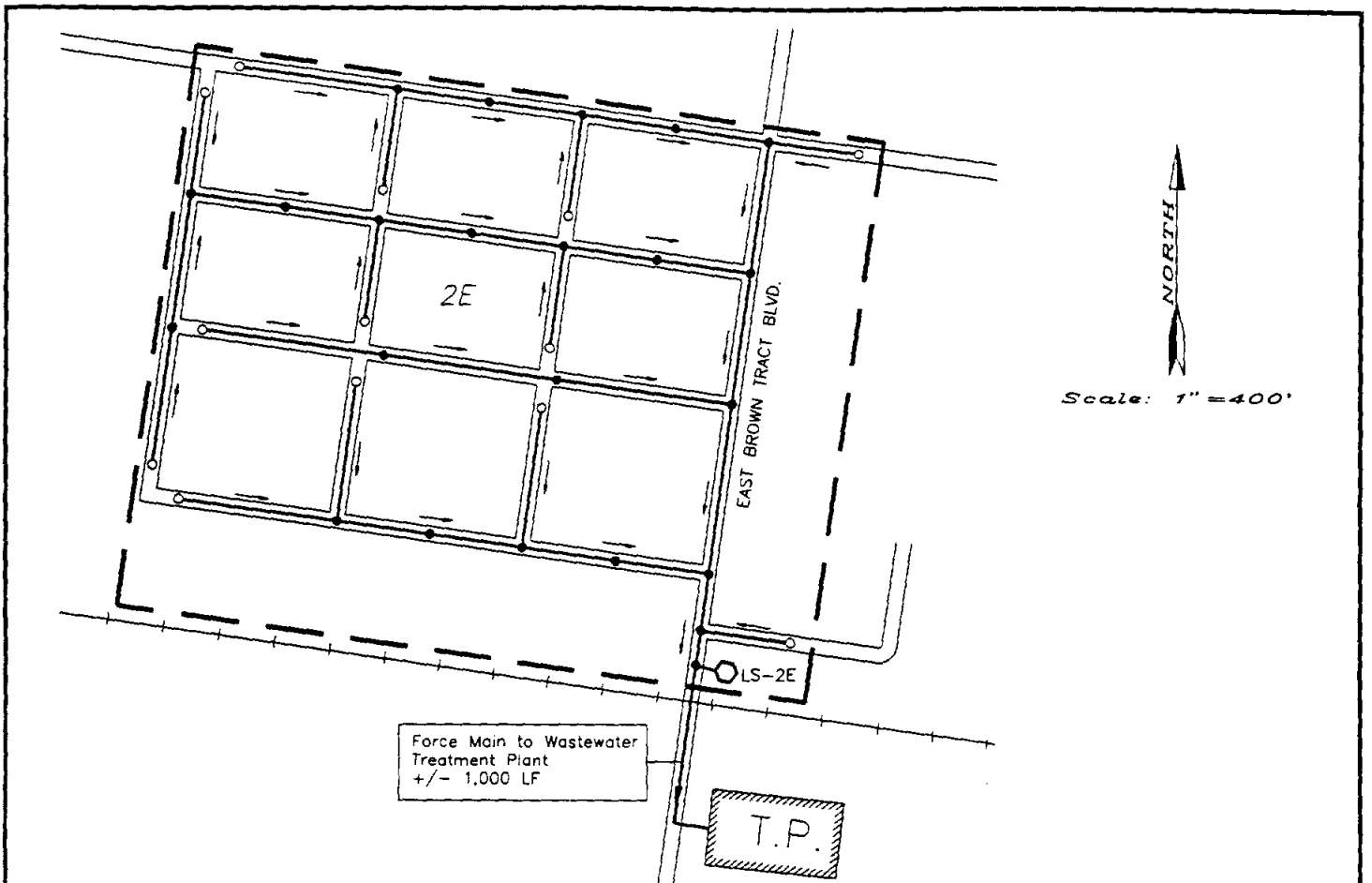

Colonia Designation	Colonia Name	Area (Ac)	2020 Population	2020 Population Density (Cap/Ac)	2020 Units	2020 Unit Density (Units/Ac)
2E	Lozano		680	13.60	139	2.78

Internal Wastewater Collection System Quantities Estimate	
ITEM	QUANTITY
6" Service Connection	139 EA
8" SDR-35 PVC Sanitary Sewer	9,000 LF
10" SDR-35 PVC Sanitary Sewer	N/A
12" SDR-35 PVC Sanitary Sewer	N/A
15" SDR-35 PVC Sanitary Sewer	N/A
18" SDR-35 PVC Sanitary Sewer	N/A
Clean Out	12 EA
Manhole	23 EA
4" PVC Force Main	1,000 LF
6" PVC Force Main	N/A
8" PVC Force Main	N/A
10" PVC Force Main	N/A
12" PVC Force Main	N/A
LS-2E 200 GPM (3.5HP)	1 EA
<b>TOTAL ESTIMATED COST</b>	<b>\$ 566,019</b>

<b>Cameron County Regional Water and Wastewater Planning Study</b>
Figure 5-90 Site Map of Lozano (2E)
Prepared For: Texas Water Development Board and Cameron County Water Development Board
Prepared By: The Water Resources Planning Group
August 1990

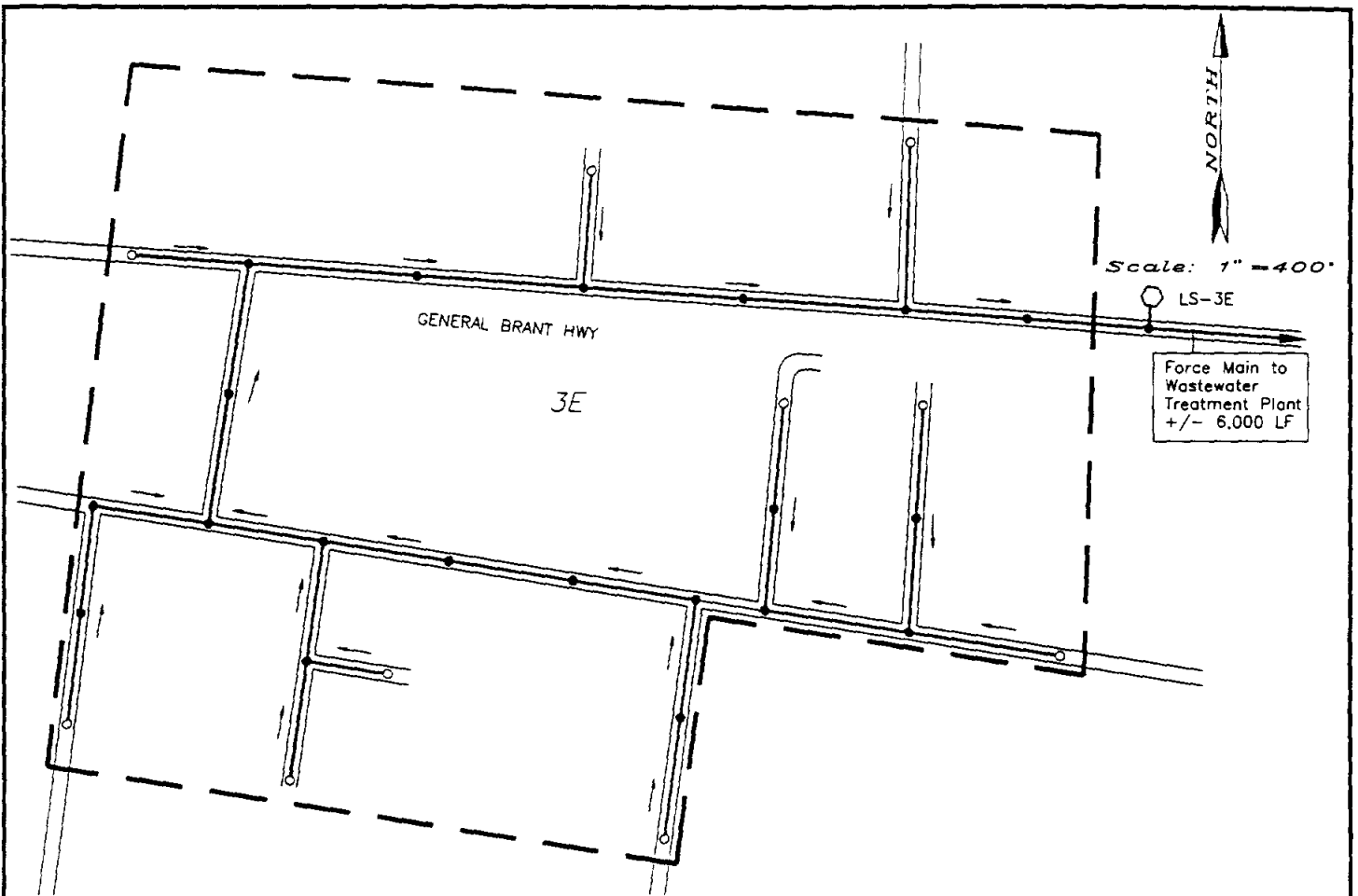

Colonia Designation	Colonia Name	Area (Ac)	2020 Population	2020 Population Density (Cap/Ac)	2020 Units	2020 Unit Density (Units/Ac)
3E	La Tina Ranch	59	662	11.22	135	2.29

Internal Wastewater Collection System Quantities Estimate	
ITEM	QUANTITY
6" Service Connection	135 EA
8" SDR-35 PVC Sanitary Sewer	8,670 LF
10" SDR-35 PVC Sanitary Sewer	N/A
12" SDR-35 PVC Sanitary Sewer	N/A
15" SDR-35 PVC Sanitary Sewer	N/A
18" SDR-35 PVC Sanitary Sewer	N/A
Clean Out	10 EA
Manhole	21 EA
4" PVC Force Main	6,000 LF
6" PVC Force Main	N/A
8" PVC Force Main	N/A
10" PVC Force Main	N/A
12" PVC Force Main	N/A
LS-3E 195 GPM (3.0 HP)	1 EA
<b>TOTAL ESTIMATED COST</b>	<b>\$ 585,266</b>

**Cameron County Regional Water and Wastewater Planning Study**

**Figure 5-91  
Site Map of La Tina Ranch (3E)**

**Prepared For:  
Texas Water Development Board  
and Cameron County Water Development Board**

**Prepared By:  
The Water Resources Planning Group**

**August 1990**

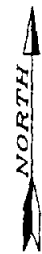
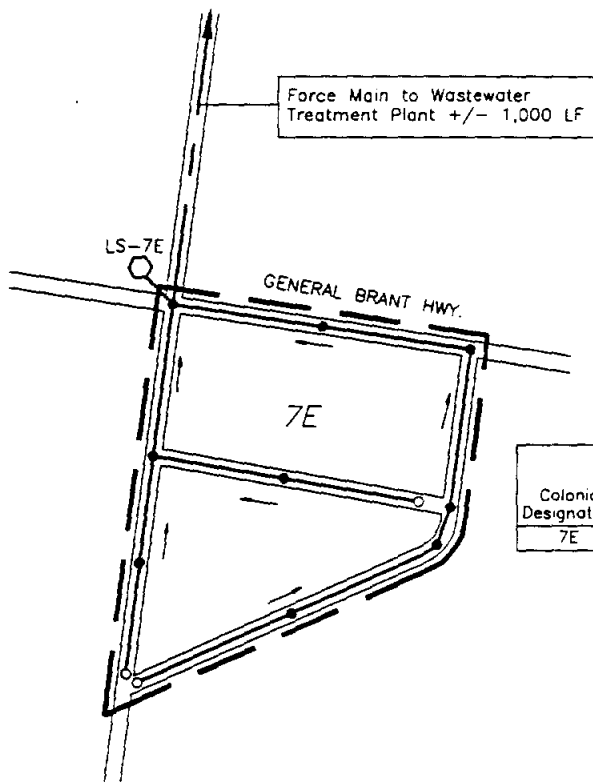

Scale: 1" = 400'

Colonia Designation	Colonia Name	Area (Ac)	2020 Population	2020 Population Density (Cap/Ac)	2020 Units	2020 Unit Density (Units/Ac)
7E	Las Yescas	16	281	17.56	57	3.56

Internal Wastewater Collection System Quantities Estimate	
ITEM	QUANTITY
6" Service Connection	57 EA
8" SDR-35 PVC Sanitary Sewer	3,200 LF
10" SDR-35 PVC Sanitary Sewer	N/A
12" SDR-35 PVC Sanitary Sewer	N/A
15" SDR-35 PVC Sanitary Sewer	N/A
18" SDR-35 PVC Sanitary Sewer	N/A
Clean Out	3 EA
Manhole	9 EA
3" PVC Force Main	1,000 LF
6" PVC Force Main	N/A
8" PVC Force Main	N/A
10" PVC Force Main	N/A
12" PVC Force Main	N/A
LS-7E 85 GPM (1.5 HP)	1 EA
<b>TOTAL ESTIMATED COST</b>	<b>\$ 261,333</b>

<b>Cameron County Regional Water and Wastewater Planning Study</b>
<b>Figure 5-92 Site Map of Las Yescas (7E)</b>
<b>Prepared For: Texas Water Development Board and Cameron County Water Development Board</b>
<b>Prepared By: The Water Resources Planning Group</b>
<b>August 1990</b>

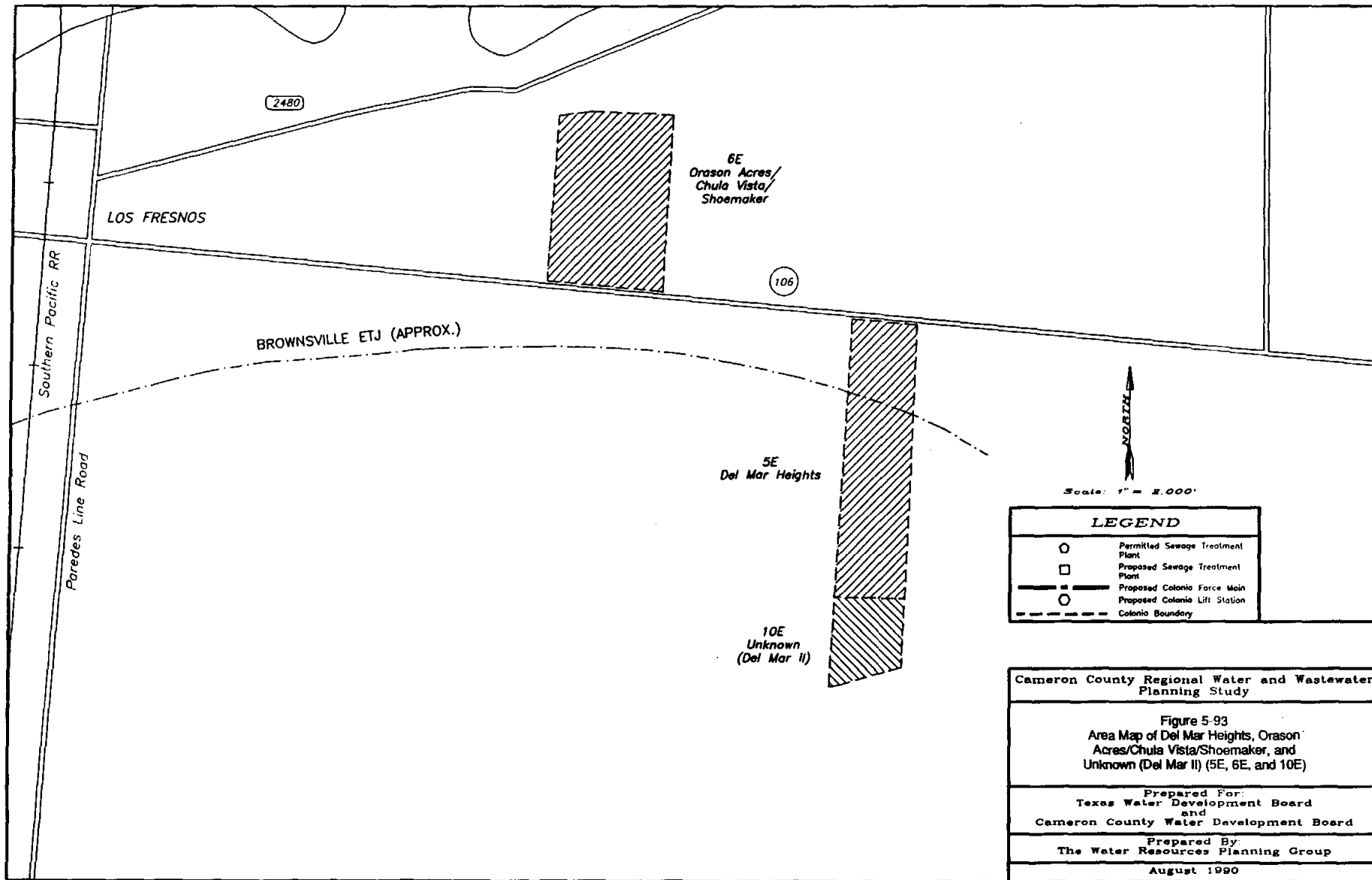

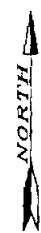
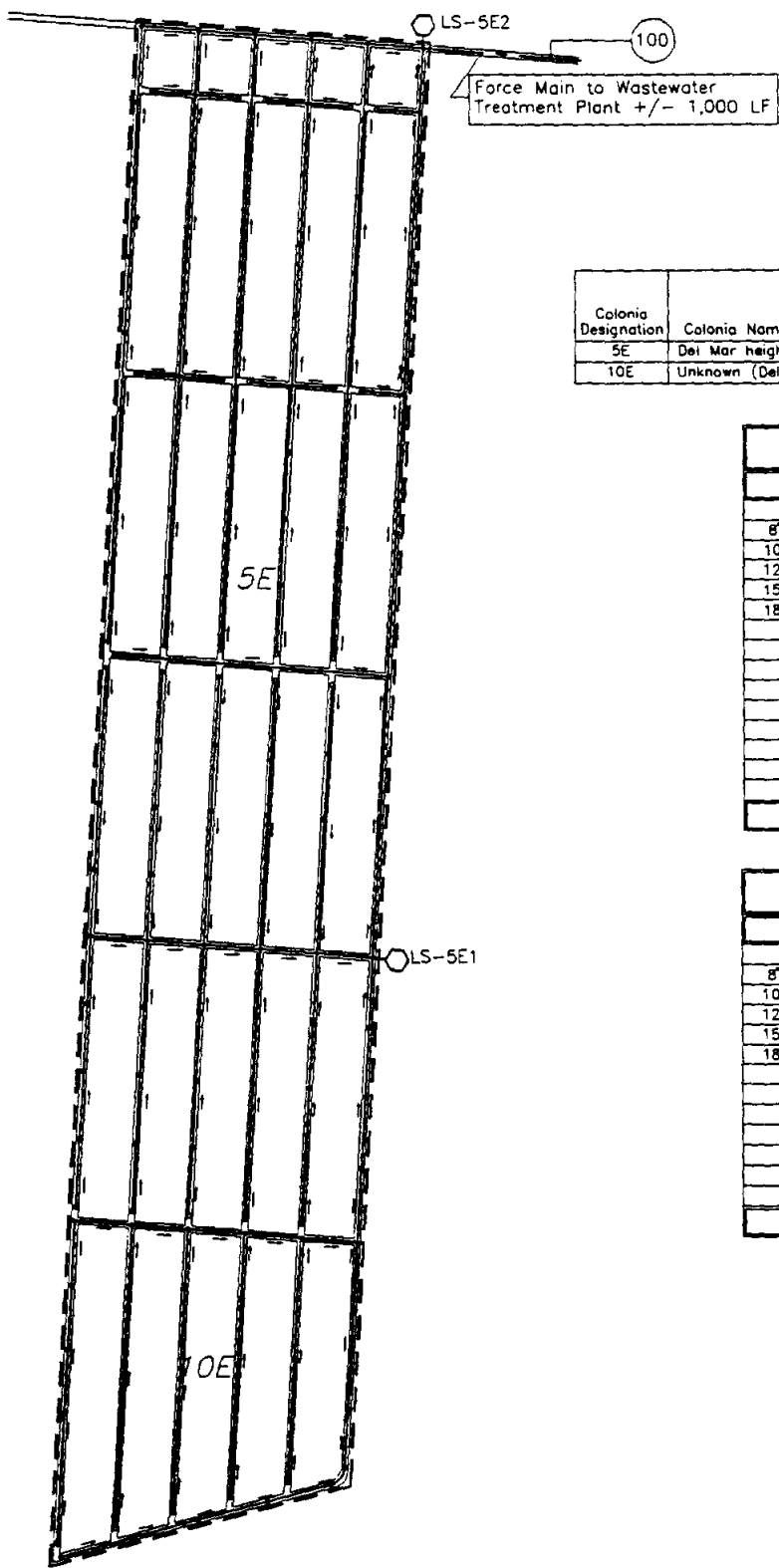

Scale: 1" = 1,000'

Colonia Designation	Colonia Name	Area (Ac)	2020 Population	2020 Population Density (Cap/Ac)	2020 Units	2020 Unit Density (Units/Ac)
5E	Del Mar heights	206	483	2.34	99	0.48
10E	Unknown (Del Mar II)	62	290	4.68	59	0.95

5E

Internal Wastewater Collection System Quantities Estimate	
ITEM	QUANTITY
6" Service Connection	99 EA
8" SDR-35 PVC Sanitary Sewer	43,650 LF
10" SDR-35 PVC Sanitary Sewer	N/A
12" SDR-35 PVC Sanitary Sewer	N/A
15" SDR-35 PVC Sanitary Sewer	N/A
18" SDR-35 PVC Sanitary Sewer	N/A
Clean Out	26 EA
Manhole	97 EA
4" PVC Force Main	150 LF
6" PVC Force Main	1,000 LF
8" PVC Force Main	N/A
10" PVC Force Main	N/A
12" PVC Force Main	N/A
LS-5E1 115 GPM (1.0 HP)	1 EA
LS-5E2 230 GPM (2.0 HP)	1 EA
<b>TOTAL ESTIMATED COST</b>	<b>\$ 1,658,105</b>

10E

Internal Wastewater Collection System Quantities Estimate	
ITEM	QUANTITY
6" Service Connection	59 EA
8" SDR-35 PVC Sanitary Sewer	11,350 LF
10" SDR-35 PVC Sanitary Sewer	N/A
12" SDR-35 PVC Sanitary Sewer	N/A
15" SDR-35 PVC Sanitary Sewer	N/A
18" SDR-35 PVC Sanitary Sewer	N/A
Clean Out	6 EA
Manhole	32 EA
4" PVC Force Main	N/A
6" PVC Force Main	N/A
8" PVC Force Main	N/A
10" PVC Force Main	N/A
12" PVC Force Main	N/A
<b>TOTAL ESTIMATED COST</b>	<b>\$ 415,451</b>

**Cameron County Regional Water and Wastewater Planning Study**

**Figure 5-94**  
**Site Map of Del Mar Heights and Unknown (Del Mar II) (5E and 10E)**

Prepared For:  
**Texas Water Development Board**  
**and Cameron County Water Development Board**

Prepared By:  
**The Water Resources Planning Group**

**August 1990**



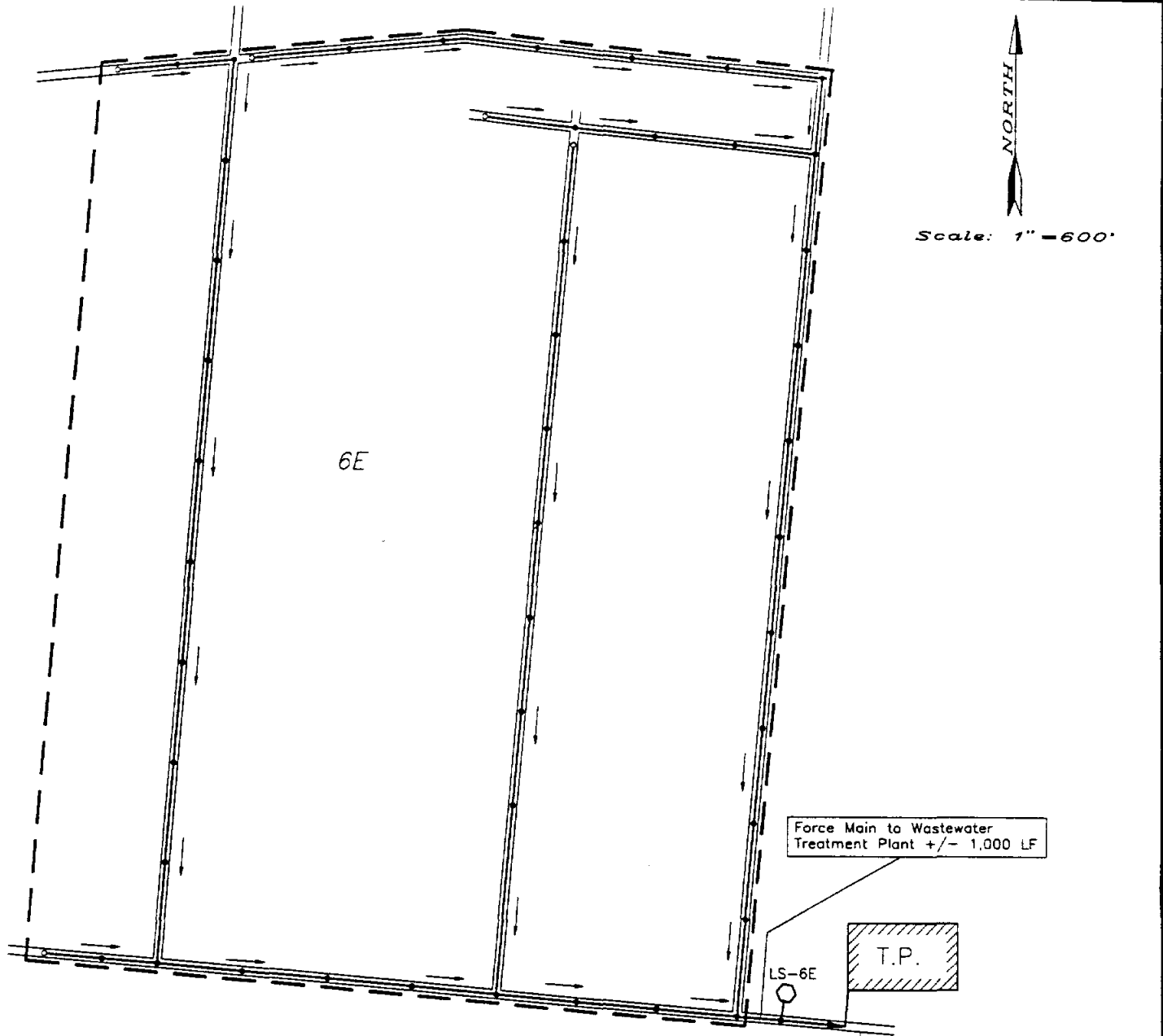

Colonia Designation	Colonia Name	Area (Ac)	2020 Population	2020 Population Density (Cap./Ac)	2020 Units	2020 Unit Density (Units./Ac)
6E	Orason/Chula Vista/Shoemaker	211	464	2.20	95	0.45

Internal Wastewater Collection System Quantities Estimate	
ITEM	QUANTITY
6" Service Connection	95 EA
8" SDR-35 PVC Sanitary Sewer	17,110 LF
10" SDR-35 PVC Sanitary Sewer	N/A
12" SDR-35 PVC Sanitary Sewer	N/A
15" SDR-35 PVC Sanitary Sewer	N/A
18" SDR-35 PVC Sanitary Sewer	N/A
Clean Out	5 EA
Manhole	45 EA
4" PVC Force Main	1,000 LF
6" PVC Force Main	N/A
8" PVC Force Main	N/A
10" PVC Force Main	N/A
12" PVC Force Main	N/A
LS-6E 140 GPM (1.7HP)	1 EA
<b>TOTAL ESTIMATED COST</b>	<b>\$ 750,817</b>

**Cameron County Regional Water and Wastewater Planning Study**

---

**Figure 5-95  
Site Map of Orason Acres/Chula Vista/Shoemaker (6E)**

---

**Prepared For:  
Texas Water Development Board  
and Cameron County Water Development Board**

---

**Prepared By:  
The Water Resources Planning Group**

---

**August 1990**

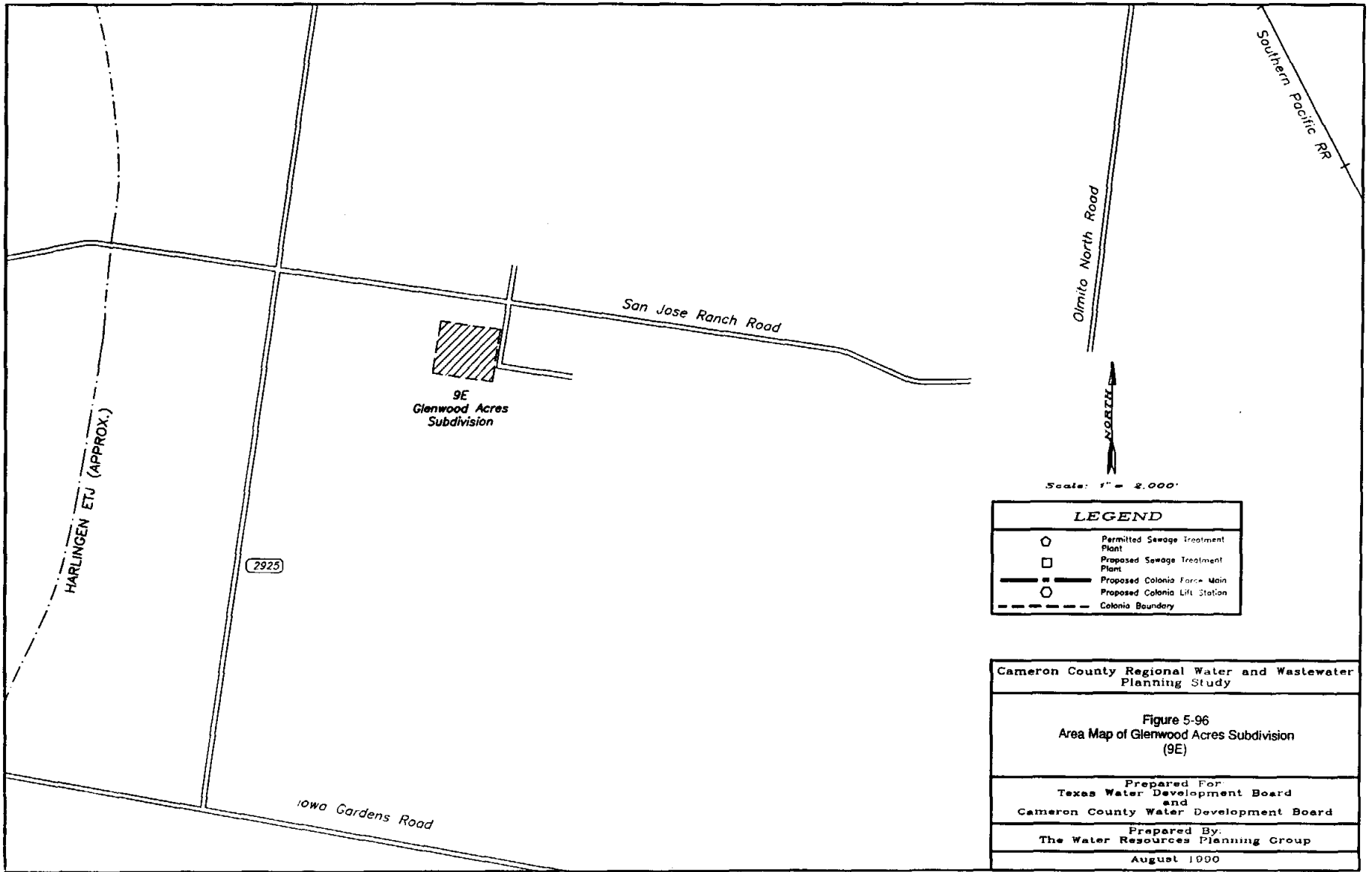

Cameron County Regional Water and Wastewater Planning Study

Figure 5-96  
Area Map of Glenwood Acres Subdivision (9E)

Prepared For  
Texas Water Development Board  
and  
Cameron County Water Development Board

Prepared By:  
The Water Resources Planning Group

August 1990

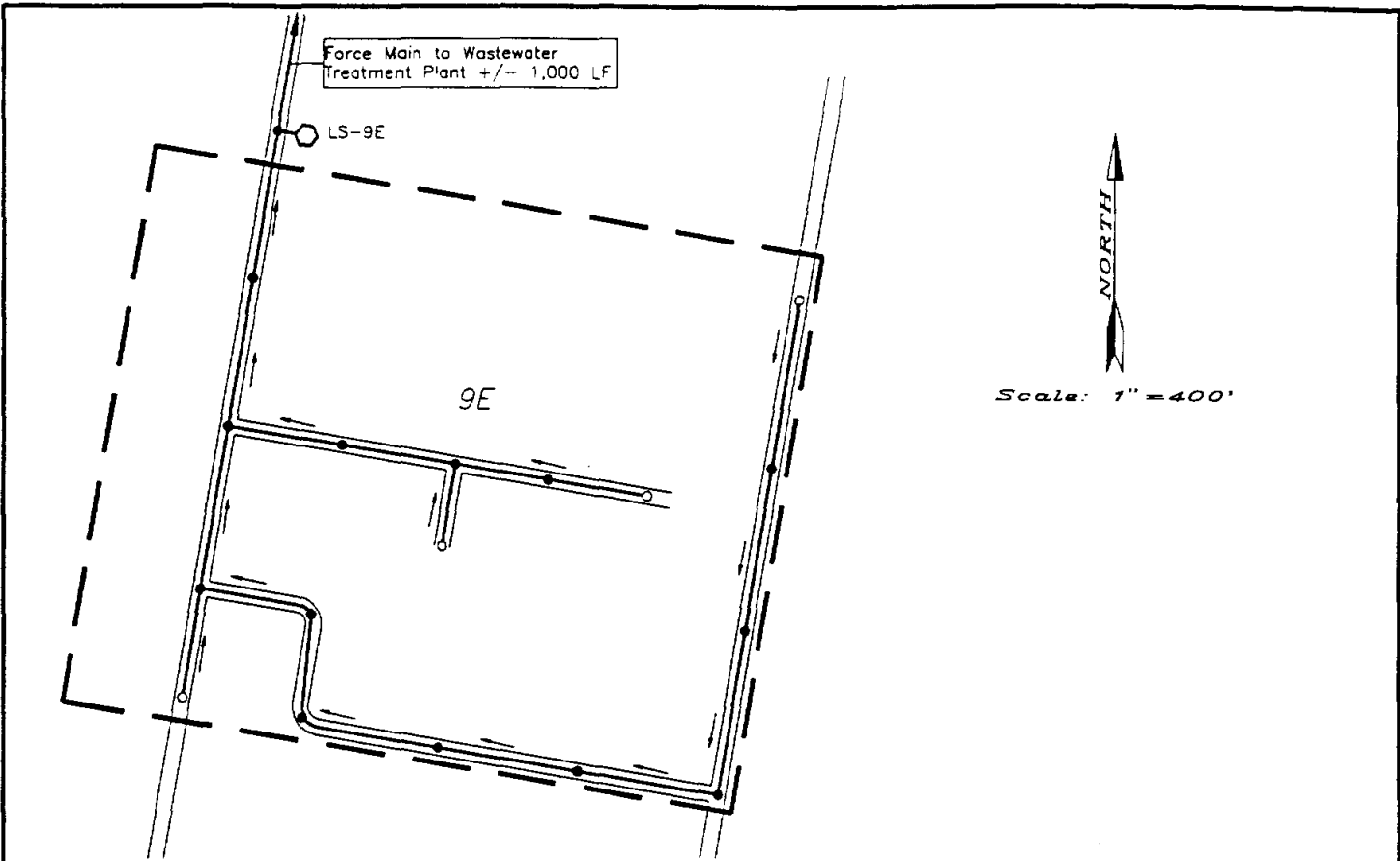

Colonia Designation	Colonia Name	Area (Ac)	2020 Population	2020 Population Density (Cap/Ac)	2020 Units	2020 Unit Density (Units/Ac)
9E	Glenwood Acres Subdivision	32	218	6.81	45	1.41

Internal Wastewater Collection System Quantities Estimate	
ITEM	QUANTITY
6" Service Connection	45 EA
8" SDR-35 PVC Sanitary Sewer	4,750 LF
10" SDR-35 PVC Sanitary Sewer	N/A
12" SDR-35 PVC Sanitary Sewer	N/A
15" SDR-35 PVC Sanitary Sewer	N/A
18" SDR-35 PVC Sanitary Sewer	N/A
Clean Out	4 EA
Manhole	14 EA
3" PVC Main Force	1,000 LF
6" PVC Force Main	N/A
8" PVC Force Main	N/A
10" PVC Force Main	N/A
12" PVC Force Main	N/A
LS-9E 65 GPM (1.0 HP)	1 EA
<b>TOTAL ESTIMATED COST</b>	<b>\$ 265,995</b>

<b>Cameron County Regional Water and Wastewater Planning Study</b>
<b>Figure 5-97</b> <b>Site Map of Glenwood Acres Subdivision (9E)</b>
<b>Prepared For:</b> <b>Texas Water Development Board</b> <b>and Cameron County Water Development Board</b>
<b>Prepared By:</b> <b>The Water Resources Planning Group</b>
<b>August 1990</b>

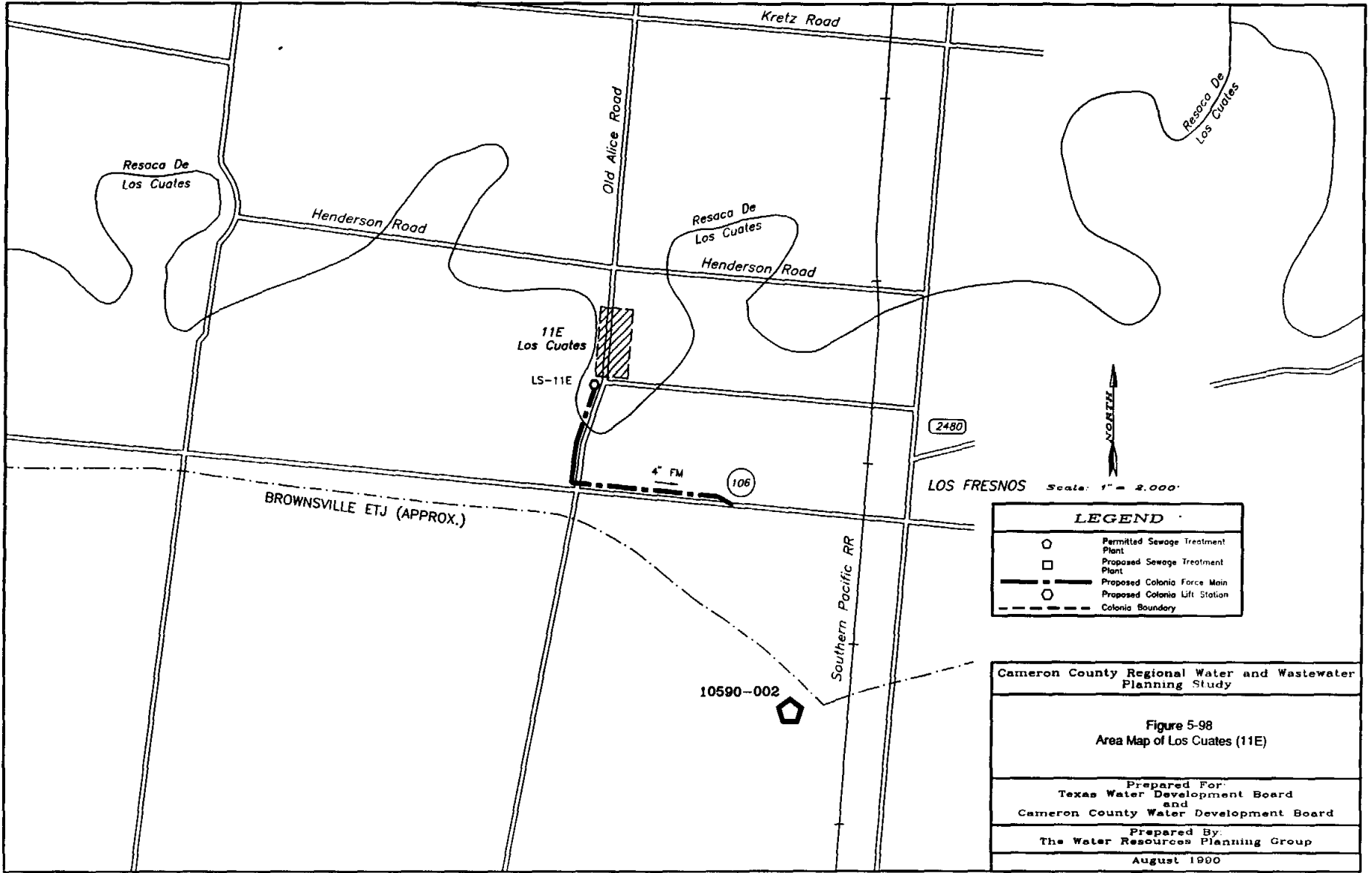

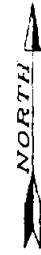

Scale: 1" = 400'

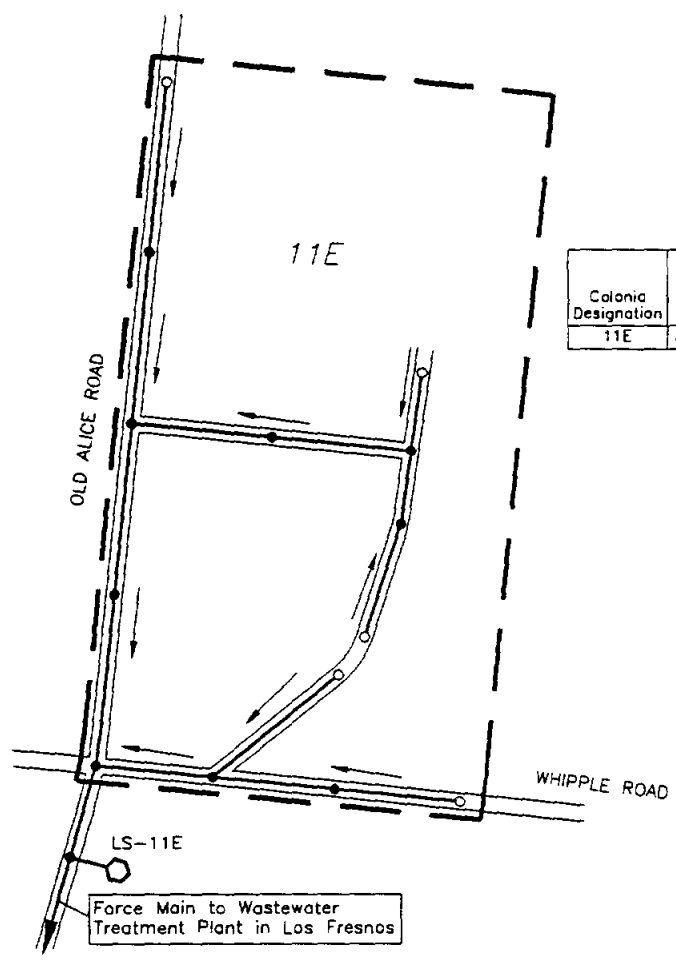

Colonia Designation	Colonia Name	Area (Ac)	2020 Population	2020 Population Density (Cap/Ac)	2020 Units	2020 Unit Density (Units/Ac)
11E	Los Cuates	22	261	11.86	53	2.41

Internal Wastewater Collection System Quantities Estimate	
ITEM	QUANTITY
6" Service Connection	53 EA
8" SDR-35 PVC Sanitary Sewer	3,750 LF
10" SDR-35 PVC Sanitary Sewer	N/A
12" SDR-35 PVC Sanitary Sewer	N/A
15" SDR-35 PVC Sanitary Sewer	N/A
18" SDR-35 PVC Sanitary Sewer	N/A
Clean Out	5 EA
Manhole	10 EA
4" PVC Force Main	14,000 LF
6" PVC Force Main	N/A
8" PVC Force Main	N/A
10" PVC Force Main	N/A
12" PVC Force Main	N/A
LS-11E 80 GPM (2.5 HP)	1 EA
<b>TOTAL ESTIMATED COST</b>	<b>\$ 439,666</b>

<b>Cameron County Regional Water and Wastewater Planning Study</b>
<b>Figure 5-99 Site Map of Los Cuates (11E)</b>
<b>Prepared For: Texas Water Development Board and Cameron County Water Development Board</b>
<b>Prepared By: The Water Resources Planning Group</b>
<b>August 1990</b>

## **6.0 WATER CONSERVATION AND DROUGHT MANAGEMENT PLAN**

### **6.1 Introduction**

#### **6.1.1 Planning Area and Project**

The service area of this study is the unincorporated areas of Cameron County. And the incorporated area with the City of Brownsville; however, the majority of the unincorporated area population is grouped into relatively small communities. With the exception of the City of Brownsville, many of these communities are either not served or underserved by a centralized water supply system and virtually none are served by a centralized wastewater collection and treatment system. Therefore, many of the conventional water conservation measures normally applied in urban or other rural areas are not directly applicable except within Brownsville.

An objective of the study was to determine the availability and adequacy of current and future treated water supplies and wastewater options available to rural customers of Cameron County, as well as, wastewater collection and treatment options when water becomes more available, the impetus to conserve generally weakens and wasteful consumption increases. Thus it is imperative that a comprehensive water conservation program be adopted from the beginning and rigorously enforced to minimized capital and operation and maintenance costs for both water and wastewater services.

#### **6.1.2 Need for and Goals of Program**

The Texas Water Development Board has promulgated Financial Assistance Rules which require water conservation planning for any entity receiving financial assistance from the TWDB. These planning requirements are designed to encourage cost-effective regional water supply and wastewater treatment facility development. On November 5th, 1985, Texas voters approved an amendment to the Texas Constitution that provided for the implementation of HB 2. Previous to this study, the CCWB has not developed a comprehensive plan for water conservation or drought contingency management of available supplies. This document provides specific guidelines for developing a water conservation and drought management program that will meet the regulatory requirements of the TWDB for the CCWB Planning Area.

Since the early 1960s, per capita water use in the state has increased approximately four gallons per capita per decade. More important, per capita water use during droughts is typically about one third greater than during periods of average precipitation. Thus, the goals of the program are to reduce overall water usage through water conservation practices and to provide for a reduction in water usage during times of shortage.

Water use in the residential and commercial sectors involves day-to-day activities of all citizens of the state, and includes drinking, bathing, cooking, toilet flushing, fire protection, lawn watering, swimming pools, laundry, dishwashing, car washing and sanitation. In addition, rural areas, served by the CCWB member WSCs, carry the additional demands of supporting small-scale private livestock production and the, often not-so-small, family garden. The objective of a conservation program is to reduce the quantity of water required for each of these activities, where practical, through implementation of efficient water use practices. The drought contingency program provides procedures for both voluntary and mandatory actions placed in effect to temporarily reduce usage demand during a water shortage crisis. Drought contingency procedures include water conservation and prohibition of certain uses. Both are tools that CCWB member WSC managers and officials will have available to them in order to effectively operate in all situations.

The water conservation plan outlined herein has the overall objective of reducing water consumption in the CCWB service area. Implementation of this plan will also reduce the amount of wastewater needing treatment and disposal. Although the impetus for this report is regional planning for water supply needs, it focuses on measures that specifically reduce the amount of water used and, ultimately, on the amount of wastewater produced. Such measures will have the effect of extending the time until additional water and wastewater treatment capacity must be provided.

Various cities throughout the country have adopted water conservation techniques and technologies depending upon the severity of their water supply situation. In particular, California has taken significant steps to reduce water consumption, and here in Texas, Austin has an aggressive water conservation program. Drawing on the experiences of some of these cities, some assumptions about the feasibility, cost and effectiveness of specific measures can be made. For the purpose of reducing the quantities of water required, two of the measures outlined below deserve particular attention: adopting vigorous plumbing codes for new construction and retrofitting.

According to figures developed in Section 3.0, between 1990 and 2020, the population of the study area is expected to at least double. Under drought conditions, when consumption is typically at its highest, and without implementation of water conservation measures, a doubling of the population would increase demand from its current 5,200 AF/yr to over 13,500 AF/yr (TDWR, 1989). With such high rates of growth, it is evident that the greatest savings in water usage can be realized by adopting stringent plumbing codes for new construction. Nationwide it is being realized that the marginal cost of supplying new water sources and water and wastewater treatment facilities is so high, that new plumbing codes that reduce water usage by 25-30 percent are the most economical solution. However, because water use in rural areas are less weighted toward domestic functions, lesser reductions on the order of 10-15% can be expected.

Existing facilities can also be retrofitted in order to reduce water consumption. Although this may involve some capital outlay, all of the measures are cost-effective, and various schemes have been devised to recover the costs. For instance, a plan for San Antonio assumes that a 2 percent increase in water and wastewater rates for 5 years would raise enough money to cover a \$100 rebate for each customer retrofitting a toilet to flush on 1.5 gallons (resulting in an overall savings on the customer's water and wastewater bill). An aggressive retrofit program can result in water savings of 15-25 percent per residence. With market penetration typically running at 20-50 percent, this would result in an overall water consumption savings of around 5 percent. In its water conservation program, the City of Austin estimates a 6.7 percent savings within 5 years. This program consists of substituting low-flow shower heads, installing toilet dams and checking for leaks. The benefit/cost ratio is estimated at more than ten, with an average savings to the customer of \$52/year from reductions in water, wastewater and electricity.

In Figure 6-1, drought condition water demands through the year 2020 for the entire CCWB service area is shown without implementation of water conservation measures. Also shown are the flows that would result from the adoption of the two measures outlined above. Overall savings in wastewater flows by 2020 are approximately 15% or approximately 2,000 AF/yr. This estimate is based on the following assumptions:

- adoption of a code that would reduce water consumption in all new construction from the current rural area statewide average of 140-160 gcd to 125 gcd;
- this code would be phased in during the 1990s and early 2000s ( a net water savings of 2% by 1995; 5% by 2000; 7-1/2% by 2005; 10% by 2010; and 12-1/2% by 2015 and 15% by 2020);
- existing uses could be reduced by 5 percent through retrofitting and other conservation measures.

These savings in water demand can be related directly to savings in water supply procurement, treatment and distributions costs as well as wastewater disposal costs. By reducing average daily demand and peak 2 hour demands by as much as 15% percent, water treatment and distribution system requirements will be commensurably reduced by 15% percent. Operation and maintenance costs to the water system infrastructure will be lower because of lower chemical requirements, reduced pumping requirements, and appropriate pump station and line sizing. Design of urban water treatment and distribution systems are influenced more by fire protection requirements than average daily per capita water usage. Rural fire protection demands are less stringent; the Fire Protection Bureau requires a minimum flow rate of 500 gpm. Thus, the impacts of water conservation are not diminished by fire protection requirements.

The drought contingency program includes those measures that can cause the CCWB to significantly reduce water use on a temporary basis. These measures involve voluntary reductions, restrictions and/or elimination of certain types of water use and water rationing. Because the onset of an emergency condition is often rapid, it is important that the CCWB be prepared in advance. Further, the citizen or customer



must know that certain measures not used in the water conservation program may be necessary if a drought or other emergency condition occurs.

## 6.2 Long-term Water Conservation

### 6.2.1 Plan Elements

Nine principal water conservation methods are delineated as part of the proposed water conservation plan.

#### Education and Information

The CCWB will promote water conservation by informing water users about ways to save water inside of homes and other buildings, in landscaping and lawn maintenance, and in recreational uses. Information will be distributed to water users as follows:

##### Initial Year:

- The initial year shall include the distribution of educational materials outlined in the Maintenance Program section.
- Distribution of a fact sheet explaining the newly-adopted Water Conservation Program and the elements of the Drought Contingency Plan. The initial fact sheet shall be included with the first distribution of educational material.
- In addition to activities scheduled in the Maintenance Program, an outline of the program and its benefits shall be distributed either through the mail or as a door-to-door hand-out.

##### Maintenance Program:

- Distribution of educational materials will be made semi-annually, timed to correspond with peak summer demand periods. Such material will incorporate information available from the American Water Works Association (AWWA), Texas Water Development Board (TWDB) and other similar associations in order to expand the scope of this project. A wide range of materials may be obtained from:

Texas Water Development Board  
P.O. Box 13231, Capitol Station  
Austin, Texas 78711-3231

- New customers will be provided with a similar package of information as that developed for the initial year, namely, educational material, a fact sheet explaining both the Water Conservation Pro-

gram and the elements of the Drought Contingency Plan, and a copy of "Water Saving Methods that can be Practiced by the Individual Water User."

### Plumbing Codes

Each of the CCWB member WSCs currently adhere to and enforce independent plumbing code for their respective service areas. These Codes have been in effect for several years. During the 1990s a more stringent unified CCWB Plumbing Code, modeled after the Massachusetts Code, will be adopted for all new construction and remodelled structures. The most significant components under consideration are:

- showers used for other than safety reasons shall be equipped with approved flow control devices to limit total flow to a maximum of 3 gallons per minute (gpm);
- toilets shall use a maximum of 1.6 gallons per flush;
- urinals shall use a maximum of 1.5 gallons per flush.

### Retrofit Program

The CCWB will make available, through its education and information programs, pertinent information for the purchase and installation of plumbing fixtures, lawn watering equipment and appliances. The advertising program will inform existing users of the advantages of installing water saving devices. The CCWB will contact local plumbing and hardware stores and encourage them to stock water conserving fixtures, including retrofit devices.

In addition, the CCWB will embark upon an aggressive retrofit program. Several alternatives are summarized in Table 6-1. Market penetration is based on the experience of other cities offering such programs. Savings are calculated on the basis of 4.9 persons per household for year 2020, a total of 26,651 residences in the Facility Planning Area.

The least cost alternative is to deliver two packages/house containing two flow restrictors, a plastic restrictor for a shower head, a toilet bag and two dye tablets. Based on past experience, the toilet bags are the most acceptable to customers and could be expected to realize savings of 4.8 gpd in participating households. A more acceptable and more permanent option is to provide customers with low-flow shower heads and toilet dams. Because of the greater costs associated with providing these items, vouchers would be included in the water bill to be exchanged at convenient locations for each water supply system. It is assumed that most of the equipment claimed through this mechanism would be installed. Another more fool-proof system, used extensively in the City of Austin, involves the installation of low-flow shower heads and toilet dams at no charge to the customer. In Austin, market penetration has exceeded 50 percent and in participating household has resulted in water savings of around 15 percent of household

usage. A fourth option is to provide rebates of \$100 to customers who replace their toilets with those that use on 1.5 gallons per flush.

**Table 6-1  
 Expected Savings Through Implementation  
 of a Water Use Retrofit Program**

Action	Cost Per House <sup>a/</sup>	Savings Per House <sup>b/</sup>	Penetration <sup>c/</sup>	Total Savings <sup>d/</sup>	Total Cost <sup>e/</sup>	Cost Per gpd <sup>f/</sup>
Distribution of Water Savings Kits <sup>g/</sup>	\$0.50	28.9 gpd	50%	120,643 gpd	\$2,087	\$0.017
Vouchers for Shower Heads and Toilet Dams <sup>h/</sup>	\$4.00	55.7 gpd	20%	93,000 gpd	\$6,679	\$0.072
Installation of Shower Heads and Toilet Dams <sup>i/</sup>	\$10.00	56.7 gpd	50%	236,694 gpd	\$41,745	\$0.176
Refund for Replacing Toilets <sup>j/</sup>	\$100.00	66.7 gpd	10%	55,694 gpd	\$83,490	\$1.499

- <sup>a/</sup> Assumes one bathroom per single-family residence.
- <sup>b/</sup> Based on 125 gpd and 4.90 persons per residence.
- <sup>c/</sup> Percentage of residences participating fully in the program.
- <sup>d/</sup> Based on current 8,349 residences in CCWDB Colonia Study Area.
- <sup>e/</sup> Total Program implementation cost.
- <sup>f/</sup> Cost per gpd saved.
- <sup>g/</sup> Assumes free distribution to all services area residences @ one kit per residence.
- <sup>h/</sup> Assumes participant retrieval of kits @ one kit per residence.
- <sup>i/</sup> Assumes installation by private contractors.
- <sup>j/</sup> Assumes \$100 per toilet.

**Water Rate Structure**

The PUB uses a uniform rate structure for all residential users. That is to say that consumers pay the same unit rate for water regardless of usage. The PUB, however, charges for only 80% of the first 10,000 gal per month; thus, effectively operating as an inclining block rate system.

**Universal Metering**

All water users, including utility and public facilities are currently metered. Also, master meters are installed and periodically calibrated at all existing water sources. All new construction, including multi-family dwellings, are separately metered. The program of universal metering will continue, and is made part of the Water Conservation Plan.

The CCWB, through their computer billing system, currently monitors water consumption and inspects meters that vary from previously established norms. In addition, the CCWB could operate under the following meter maintenance and replacement programs:

<u>Meter Type</u>	<u>Test and Replacement Period</u>
Master meter	Annually
Larger than 1 inch	Annually
1-inch and less	Every 5 years

Through a successful meter maintenance program, coupled with computerized billing and leak detection programs, the CCWB will be able to maintain water delivery rates, from production to consumer, in the 85 percentile range.

#### Water Conservation Landscaping

In order to reduce the demands placed on the water system by landscape, livestock and garden watering, the CCWB, through its information and education program, will encourage customers and local landscaping companies to utilize water saving practices during installation of landscaping, gardens and stock watering facilities for residential and commercial institutions. The following methods will be promoted by the education and information program:

- Encourage subdivisions to require drought-resistant grasses and plants that require less water.
- Initiate a program to encourage the adoption of xeriscaping.
- Encourage landscape architects to use drought-resistant plants and grasses; and efficient irrigation systems.
- Encourage licensed irrigation contractors to use drip irrigation systems, when possible, and to design all irrigation systems with conservation features such as sprinklers that emit large drops rather than a fine mist and a sprinkler layout that accommodates prevailing wind patterns.
- Encourage commercial establishments to use drip irrigation for landscape watering, when practical, and to install only ornamental fountains that use minimal quantities of water, including recycling features.
- Encourage local nurseries to offer adapted, drought-resistant plants and grasses and efficient watering devices.

#### Leak Detection and Repair

The CCWB and its member WSCs will utilize modern leak detection techniques, including listening devices, in locating and reducing leaks. Through their respective billing program, each WSC will identify excessive usage and take steps to determine whether it is a result of leakage. Once located, all leaks will be immediately repaired. A continuous leak detection and repair program is vital to the WSC's profitability. The CCWB is confident that the program more than pays for itself.

### Recycle and Reuse

The CCWB does not own or operate any conventional wastewater treatment facilities. Nearly all CCWB customers utilize some sort of on-site wastewater treatment and disposal method. However, the CCWB will make available to its customers, information on on-site reuse of non-sewage wastewater.

### 6.3 Implementation/Enforcement

The staff of the CCWB will administer the Water Conservation Program. They will oversee the execution and implementation of all elements of the program and supervise the keeping of adequate records for program verification.

The plan will be enforced through the adoption of the Water Conservation Plan by each of the CCWB member or water supplier in the following manner:

- Water service taps will not be provided to customers unless they have met the plan requirements;
- The proposed block rate structure should encourage retrofitting of old plumbing fixtures that use large quantities of water; and
- The building inspector will not certify new construction that fails to meet plan requirements.

The CCWB member WSCs will adopt the final approved plan and commit to maintain the program for the duration of the CCWB's financial obligation to the State of Texas.

### Annual Reporting

In addition to the above outlined responsibilities, the CCWB staff will submit an annual report to the Texas Water Development Board on the Water Conservation Plan. The report will include the following:

- Information that has been issued to the public.
- Public response to the plan.
- The effectiveness of the water conservation plan in reducing water consumption, as demonstrated by production and sales records.
- Implementation progress and status of the plan.

### Contracts with Other Political Subdivisions

The CCWB will, as part of a contract for sale of water to any other political subdivision, require that entity to adopt applicable provisions of the CCWB's water conservation or already have a TWDB-approved plan in effect. These provisions will be through contractual agreement prior to the sale of water to the political subdivision.

## 6.4 Drought Management Plan

### 6.4.1 Cameron County Drought Management Authority

Nearly all public and private water supplies in Cameron County are derived, either directly or indirectly, from the Rio Grande. Those waters are regulated jointly by the United States and Mexico. The Texas Water Master, in consortium with the International Boundary and Water Commission regulates the operation of Amistad, Falcon, and Anzalduas Reservoirs as a hydrologic system to supply normal and drought condition flows to Mexico and the Lower Valley. Cameron County will adopt, and follow to the extent practicable and legally enforceable, the procedures of the Water Master and the IBWC with regards to water supply operations during hydrologic droughts.

On a local basis and where enforceable, the County will require cities to adopt drought contingency ordinances in accordance with the provisions of the drought contingency plan presented herein for the CCWDB.

### 6.4.2 Drought and/or Emergency Trigger Conditions

The County will adopt the following set of "triggers" or threshold conditions to indicate the various stages of increasing drought severity and water shortage conditions:

1. The County will recognize that a mild drought (water demand is approaching the safe capacity of the system) is in progress when the Texas Water Master (Texas Water Commission) determines that the operating reserve in Falcon and Amistad Reservoirs is at 25% capacity.
2. The County will recognize that a moderate drought (reservoir reserves are still high enough to provide an adequate supply, but the reserves are low enough to disrupt some beneficial activities) is in progress when the Texas Water Master determines that the operating reservoir in Falcon and Amistad Reservoirs is zero.
3. The County will recognize that a severe drought (reservoir reserves are low enough that there is a real possibility that the supply situation may become critical if the drought or emergency continues) is in progress when the Texas Water Master determines that the irrigation reserve in Falcon and Amistad Reservoirs is less than 50 percent of assigned capacity.
4. The County will recognize that the system is in emergency operation modes if one or more of its customer's major pumps or transmission lines in the raw water supply system fail, significantly impairing the capability to deliver water to contracting cities.

### 6.4.3 Drought and/or Emergency Measures

The County will incorporate the following measures and encourage water use by affected cities, depending on the degree of efficient severity of the drought and other system emergency conditions.

### Mild Condition Measures

1. Cities will be asked to activate an information center to answer inquiries from citizens and other customers regarding water shortage conditions and required conservation measures. The Authority will discuss the drought condition potential and its impact on the water supply situation in the news media.
2. The County will continue to advise the cities of the reservoir reserves on a monthly basis.
3. The County will request the cities to implement a voluntary daily lawn watering schedule through the media.

### Moderate Condition Measures

1. The County will inform the cities by mail and telephone that the drought has reached the moderate trigger level. This information will be given at seven-day intervals until the drought trigger condition changes.
2. The County will request that contracting cities implement mandatory lawn irrigation schedules.
3. The County will request that the contracting cities prohibit other non-essential uses such as car washing, filling of swimming pools, etc.

### Severe Drought Condition and/or System Emergency Mode

1. The County will immediately inform the cities, by telephone and mail, about the serious water supply situation. Similar action will be taken in the event of a major system failure. The news media will also be informed. Situation reports will be issued to the contracting cities and news media daily.
2. The County will request that the cities prohibit all outdoor water use.

#### 6.4.4 Drought Termination Notification

Termination of the drought/emergency condition and corresponding measures will take place when the trigger condition that initiated the drought/emergency situation no longer exists. The County will inform the member cities and the media of the end of the drought trigger or emergency condition in the same manner as they were previously informed.

## 7.0 PRELIMINARY ENVIRONMENTAL ASSESSMENT

The purpose of this section is to provide preliminary environmental support for the development of the Cameron County Regional Water and Wastewater Plan. This section is designed to accomplish two primary goals: 1) Provide a preliminary baseline assessment of environmental and cultural features that, under Federal, State, and local regulations may become of concern in the development of regional water supply, treatment and distribution, and wastewater treatment and collection facilities; and, 2) Identify potential effects and/or constraints to the development of such facilities. This section generally follows guidelines for environmental assessments as described by TWDB for state funding programs. This assessment is general and is designed to provide data for preliminary evaluation of alternative water and wastewater options. Site specific detail for a complete Environmental Assessment or Environmental Information Document will require further study. Significant environmental constraints within Cameron County are presented on the Environmental Constraints Map (USGS Quad base map) in the map report accompany this plan.

### 7.1 Purpose and Need for Project

The purpose and need for this project is described in detail in Sections 1.0, 2.0 and 3.0 of this report.

### 7.2 Project Description

The proposed project has been previously defined throughout this study. Details of proposed water and wastewater facilities to serve the colonias of Cameron County can be found in Sections 4.0 and 5.0 of this report.

### 7.3 Baseline Conditions

#### 7.3.1 Geological Elements and Soils

Cameron County is located on the nearly level coastal plain of Texas. The county gradually dips to the East toward the Gulf of Mexico at typically less than a one percent (1%) slope. Generally, the topographic features of Cameron County consists of tidal flats, resacas, backswamps, barrier islands, levees, point bars, clay dunes, depressing areas, and deltaic features of the Rio Grande. Elevations throughout the county range from sea level to approximately 70 feet MSL near Santa Maria (Williams et al., 1977).

Two (2) geologic formations are exposed in Cameron County. The Beaumont formation and the younger Holocene sediments (Williams et al., 1977). The older Beaumont formation, which is of Pleistocene age, and the Holocene sediments at the surface are separated by a contact point



which occurs as a low scarp in the area of Sweeney and Cross Lakes and, west of Harlingen, by the Arroyo Colorado which flows along the contact (Williams et al., 1977).

The older exposed Pleistocene system that outcrops along the Gulf of Mexico coastal plain is the Houston group (Sellards et al., 1981). The Houston group sediments are unconsolidated, alluvial, deltaic, and brackish-water or lagoonal deposits (Sellards et al., 1981). The Houston group is divided into two (2) formations, the Lissie sand, and the Beaumont clay (Sellards et al., 1981). The former of which is not exposed in Cameron County (BEG, 1976).

The Beaumont clay formation is present mainly in the North-western part of the county. It is 400 to 900 feet thick, about 75% to 80% sand with considerable gravel and some limestone originally deposited as caliche (Sellards et al., 1981). The Beaumont formation was largely deposited by rivers by way of natural levees and deltas systems and to a lesser extent by marine and lagoonal processes (Sellards et al., 1981). In extensive areas along the Gulf of Mexico coast the Beaumont clay formation is overlain unconformably by recent stream deposits and wind-blown beach sands (Sellards et al., 1981).

The recent Holocene sediments dominate the southern and eastern part of Cameron County. These sediments are characterized by three (3) distinct deposits: wind-blown, barrier island, and alluvial.

The wind-blown deposits are primarily found along the extreme mainland coast of Cameron County. These sediments are generally characterized as clay dunes, active dunes and dune complexes on the mainland, and stabilized sand dune deposits (BEG, 1976).

The barrier island deposits exist as part of Padre Island and to a small extent Brazos Island. These sediments are generally characterized as sand, silt and clay, mostly sand, well sorted, fine grained, with interfingers of silt and clay in the landward direction. These island deposits also include a beach ridge, spit, tidal channel, tidal delta, washover fan, and sand dune deposits (BEG, 1976).

The third and most extensive Holocene sediments in Cameron County are the alluvial or flood plain deposits. These sediments overlay greater than fifty percent (50%) of the county. These were transported by the Rio Grande and its associated streams, resacas and arroyos. These alluvial deposits in the lower River Grande are composed of a wide variety of sediments characterized as clay, silt, mainly quartz sand, dark gray to dark brown; and includes sedimentary rocks from the Cretaceous and Tertiary and a wide variety of igneous and sedimentary rocks from the Trans-Pecos of Texas, Mexico and New Mexico (BEG, 1976).

## Soil

The following paragraphs will present the general soil associations and descriptions of Cameron County (Williams, et al., 1977) as mapped by the Soil Conservation Service. These general descriptions will include soil properties that are pertinent to the proposed activity, such as landscape position, slopes, permeability and texture. A more specific quantitative listing of the engineering properties for Cameron County soils and how they relate to individual colonias within the study area are presented in Table 7-1.

The Sejita-Lomatta-Barrada soil association occupies level areas of saline, loamy and clayey soils at or near sea level and broad areas of barren clay that are inundated by high tides and heavy rains. This association occupies about 23% of the county and is generally poorly drained and very poorly drained clays and silty clay loams. Much of this association has a water table depth of 1 to 5 feet throughout the year.

The Laredo-Lomatta soil association occupies gently sloping to level areas and is well-drained to poorly drained silty clay loams and clays. This association is mainly adjacent to Laguna Atascosa National Wildlife Refuge. This association occupies about 4% of the county and a seasonal high water table exists at about 2 to 6 feet. The soils of this association occupy the slightly depressed areas and adjacent sloping areas slightly greater in elevation (1-5 feet).

The Willamar association soils are described as nearly level, somewhat poorly drained fine sandy loams and sandy clay loams. These soils comprise about 4% of Cameron County. These soils are somewhat poorly drained and have very slow permeability. A seasonal high water table exists at about 36 to 72 inches and these soils are saline.

The soils of the Laredo-Olmito association are characterized as nearly level to gently sloping, well-drained and moderately well-drained silty clayloams and silty clays. These soils generally follow the pattern of the old resacas on a low terrace of the Rio Grande. This association comprises about 19% of the county.

The Rio-Grande-Matamoros association can be described as nearly level to gently sloping, well-drained and moderately well-drained silt loams and silty clays. These soils occupy a narrow band adjacent to the Rio-Grande and the nearly level slack water areas associated with it. This association occupies about 4% of the county. These soils are geologically very young (Holocene age).

**Table 7-1  
Soils Summary and On-site  
Absorption System Suitability for  
Each Colonia**

Colonia PUB Designation	Colonia	Soils Designation	Degree and Kind of Limitation for Septic Tank Absorption Fields	Permeability (In/hr)	Depth to Seasonal High Water Table (in)	Suitable for Absorption Trench On-Site Disposal (Y/N)
1B	Cameron Park	Laredo Silty Clay Loam (0-1% Slopes)	Moderate: Percs Slowly	0.06 - 0.20	36 - 120	N
		Laredo Silty Clay Loam ( 1-3% Slopes)	Moderate: Percs Slowly	0.06 - 0.20	36 - 120	N
		Olmito Silty Clay	Severe: Percs Slowly	0.06 - 0.20	36 - 120	N
		Harlingen Clay	Severe: Percs Slowly	0.06	60 - 120	N
		Chargo Silty Clay	Severe: Percs Slowly	0.06 - 0.20	24 - 36	N
2B	Olmito	Benito Clay	Severe: Percs Slowly; Wet	< 0.06	60 - 120	N
		Benito Clay	Severe: Percs Slowly; Wet	< 0.06	60 - 120	N
		Olmito Silty Clay	Severe: Percs Slowly	0.06 - 0.20	36 - 120	N
		Laredo Silty Clay Loam (0-1% Slopes)	Moderate: Percs Slowly	0.06 - 0.20	36 - 120	N
		Tiocano Clay	Severe: Floods; Percs Slowly	< 0.06	> 74	Y
3B	Stuart Subdivision	Laredo-Urban Land Complex	-	-	36 - 120	N
		Benito Clay	Severe: Percs Slowly; Wet	< 0.06	60 - 120	N
		Benito-Urban Land Complex	-	-	60 - 120	N
		Laredo-Urban Land Complex	Moderate: Percs Slowly	0.63 - 2.0	60 - 120	N
4B	San Pedro/Cameron/Barrera Gd	Laredo Silty Clay Loam (0-1% Slopes)	Moderate: Percs Slowly	0.06 - 0.20	36 - 120	N
		Olmito Silty Clay	Severe: Percs Slowly	0.06 - 0.20	36 - 120	N
5B	King Subdivision	Olmito Silty Clay	Severe: Percs Slowly	0.06 - 0.20	36 - 120	N
		Olmito-Urban Land Complex	Severe: Percs Slowly	0.06 - 0.20	60 - 120	N
		Laredo-Urban Land Complex	-	-	60 - 120	N
6B	Alabama/Arkansas (la Coma)	Rio Grande Silty Loam	Severe: Floods	0.63 - 2.0	> 63	N
		Benito Clay	Severe: Percs Slowly; Wet	< 0.06	60 - 120	N
		Olmito Silty Clay	Severe: Percs Slowly	0.06 - 0.20	36 - 120	N
		Laredo Silty Clay Loam (0-1% Slopes)	Moderate: Percs Slowly	0.06 - 0.20	36 - 120	N
7B	Hacienda Gardens	Olmito Silty Clay	Severe: Percs Slowly	0.06 - 0.20	36 - 120	N
		Laredo Silty Clay Loam (0-1% Slopes)	Moderate: Percs Slowly	0.06 - 0.20	36 - 120	N
		Laredo Silty Clay Loam ( 1-3% Slopes)	Moderate: Percs Slowly	0.06 - 0.20	36 - 120	N
8B	Villa Nueva	Rio Grande Silty Loam	Severe: Floods	0.63 - 2.0	> 63	N
		Laredo Silty Clay Loam (0-1% Slopes)	Moderate: Percs Slowly	0.06 - 0.20	36 - 120	N
		Olmito Silty Clay	Severe: Percs Slowly	0.06 - 0.20	36 - 120	N
9B	Villa Pancho	Benito Clay	Severe: Percs Slowly; Wet	< 0.06	60 - 120	N
		Olmito Silty Clay	Severe: Percs Slowly	0.06 - 0.20	60 - 120	N
		Cameron Silty Clay	Slight	0.20 - 0.63	60 - 120	N
		Chargo Silty Clay	Severe: Percs Slowly	0.06 - 0.20	24 - 36	N
10B	Pleasant Meadows	Benito Clay	Severe: Percs Slowly; Wet	< 0.06	60 - 120	N
		Olmito Silty Clay	Severe: Percs Slowly	0.06 - 0.20	36 - 120	N
11B	Villa Cavazos	Laredo Silty Clay Loam (0-1% Slopes)	Moderate: Percs Slowly	0.06 - 0.20	36 - 120	N
		Olmito Silty Clay	Severe: Percs Slowly	0.06 - 0.20	36 - 120	N

Soils Summary (Sub-Area B) continued

Colonia PUB Designation	Colonia	Soils Designation	Degree and Kind of Limitation for Septic Tank Absorption Fields	Permeability (ln/hr)	Depth to Seasonal High Water Table (ln)	Suitable for Absorption Trench On-Site Disposal (Y/N)
12B	Barrio Subdivision	Laredo-Urban Land Complex	-	-	60 - 120	N
		Lomaíta Clay	Severe: Percs Slowly	0.06	48 - 120	N
		Laredo Silty Clay Loam (0-1% Slopes)	Moderate: Percs Slowly	0.06 - 0.20	36 - 120	N
13B	Las Cuatas	Laredo Silty Clay Loam (0-1% Slopes)	Moderate: Percs Slowly	0.06 - 0.20	36 - 120	N
		Olmito Silty Clay	Severe: Percs Slowly	0.06 - 0.20	36 - 120	N
14B	Saldivar	Harlingen Clay	Severe: Percs Slowly	0.06	60 - 120	N
		Benito Clay	Severe: Percs Slowly; Wet	< 0.06	60 - 120	N
15B	Coronado	Olmito Silty Clay	Severe: Percs Slowly	0.06 - 0.20	36 - 120	N
		Laredo-Olmito Complex	Severe: Percs Slowly	0.06 - 0.20	60 - 120	N
16B	Unknown	Laredo Silty Clay Loam (0-1% Slopes)	Moderate: Percs Slowly	0.06 - 0.20	36 - 120	N
		Benito Clay	Severe: Percs Slowly; Wet	< 0.06	60 - 120	N
		Matamoros Silty Clay	Severe: Floods; Percs Slowly	0.06 - 0.20	> 50	N
17B	Saldivar (II)	Lomaíta Clay	Severe: Percs Slowly	0.06	48 - 120	N
		Olmito Silty Clay	Severe: Percs Slowly	0.06 - 0.20	36 - 120	N
		Laredo Silty Clay Loam (0-1% Slopes)	Moderate: Percs Slowly	0.06 - 0.20	36 - 120	N
		Harlingen Clay	Severe: Percs Slowly	0.06	60 - 120	N
18B	Valle Escondido	Benito Clay	Severe: Percs Slowly; Wet	< 0.06	60 - 120	N
19B	Unnamed C	Olmito Silty Clay	Severe: Percs Slowly	0.06 - 0.20	36 - 120	N
		Laredo Silty Clay Loam (0-1% Slopes)	Moderate: Percs Slowly	0.06 - 0.20	36 - 120	N
20B	Unnamed D (Keller's Corner)	Olmito Silty Clay	Severe: Percs Slowly	0.06 - 0.20	36 - 120	N
		Benito Clay	Severe: Percs Slowly; Wet	< 0.06	60 - 120	N
		Laredo Silty Clay Loam (0-1% Slopes)	Moderate: Percs Slowly	0.06 - 0.20	36 - 120	N
21B	Texas 4	Laredo Silty Clay Loam (0-1% Slopes)	Moderate: Percs Slowly	0.06 - 0.20	36 - 120	N
		Olmito Silty Clay	Severe: Percs Slowly	0.06 - 0.20	36 - 120	N
		Laredo-Urban Land Complex	-	-	60 - 120	N
22B	511 Crossroads	Laredo Silty Clay Loam (0-1% Slopes)	Moderate: Percs Slowly	0.06 - 0.20	36 - 120	N
		Laredo Silty Clay Loam (Saline)	Moderate: Percs Slowly	0.63 - 2.0	60 - 120	N
		Chargo Silty Clay	Severe: Percs Slowly	0.06 - 0.20	24 - 36	N
23B	Illinois Heights	Olmito Silty Clay	Severe: Percs Slowly	0.06 - 0.20	36 - 120	N
		Laredo Silty Clay Loam (Saline)	Moderate: Percs Slowly	0.63 - 2.0	60 - 120	N
		Lomaíta Clay	Severe: Percs Slowly	0.06	48 - 120	N
		Laredo Silty Clay Loam (0-1% Slopes)	Moderate: Percs Slowly	0.06 - 0.20	36 - 120	N
24B	Unknown (Brownsville Airport)	Olmito Silty Clay	Severe: Percs Slowly	0.06 - 0.20	36 - 120	N
		Laredo Silty Clay Loam (0-1% Slopes)	Moderate: Percs Slowly	0.06 - 0.20	36 - 120	N
25B	Valle Hermosa	Benito Clay	Severe: Percs Slowly; Wet	< 0.06	60 - 120	N
26B	Unknown	Laredo Silty Clay Loam (0-1% Slopes)	Moderate: Percs Slowly	0.06 - 0.20	36 - 120	N
		Laredo Silty Clay Loam ( 1-3% Slopes)	Moderate: Percs Slowly	0.06 - 0.20	36 - 120	N
		Olmito Silty Clay	Severe: Percs Slowly	0.06 - 0.20	36 - 120	N
27B	Unnamed B (Hwy 802)	Olmito Silty Clay	Severe: Percs Slowly	0.06 - 0.20	36 - 120	N
		Laredo Silty Clay Loam (0-1% Slopes)	Moderate: Percs Slowly	0.06 - 0.20	36 - 120	N
28B	21	Laredo Silty Clay Loam (0-1% Slopes)	Moderate: Percs Slowly	0.06 - 0.20	36 - 120	N
		Cameron Silty Clay	Slight	0.20 - 0.63	0 - 23	N
		Olmito Silty Clay	Severe: Percs Slowly	0.06 - 0.20	36 - 120	N

Soils Summary (Sub-Area W)

Colonia PUB Designation	Colonia	Soils Designation	Degree and Kind of Limitation for Septic Tank Absorption Fields	Permeability (in/hr)	Depth to Seasonal High Water Table (in)	Suitable for Absorption Trench On-Site Disposal (Y/N)
1W	Encantada	Laredo Silty Clay Loam (0-1% Slopes)	Moderate: Percs Slowly	0.06 - 0.20	36 - 120	N
		Laredo Silty Clay Loam ( 1-3% Slopes)	Moderate: Percs Slowly	0.06 - 0.20	36 - 120	N
		Laredo-Reynosa Complex (0-1% Slopes)	Moderate: Percs Slowly	0.63 - 2.0	60 - 120	N
		Laredo-Reynosa Complex (1-3% Slopes)	Moderate: Percs Slowly	0.63 - 2.0	60 - 120	N
		Rio Grande Silty Loam Tiocono Clay	Severe: Floods Severe: Floods; Percs Slowly	0.63 - 2.0 < 0.06	> 63 60 - 120	N N
2W	Santa Maria	Laredo Silty Clay Loam (0-1% Slopes)	Moderate: Percs Slowly	0.06 - 0.20	36 - 120	N
		Laredo-Urban Land Complex	-	-	60 - 120	N
3W	La Paloma	Olmito Silty Clay	Severe: Percs Slowly	0.06 - 0.20	60 - 120	N
		Laredo Silty Clay Loam (0-1% Slopes)	Moderate: Percs Slowly	0.06 - 0.20	36 - 120	N
		Rio Grande Silty Loam	Severe: Floods	0.63 - 2.0	> 63	N
4W	Los Indios	Laredo-Urban Land Complex	-	-	60 - 120	N
		Laredo Silty Clay Loam (0-1% Slopes)	Moderate: Percs Slowly	0.06 - 0.20	36 - 120	N
5W	Bluetown	Laredo Silty Clay Loam (0-1% Slopes)	Moderate: Percs Slowly	0.06 - 0.20	36 - 120	N
		Laredo-Reynosa Complex (0-1% Slopes)	Moderate: Percs Slowly	0.63 - 2.0	60 - 120	N
6W	T2 Unknown Subdivision	Benito Clay	Severe: Percs Slowly; Wet	< 0.06	60 - 120	N
		Raymondville Clay Loam	Severe: Percs Slowly	0.20 - 0.63	60 - 120	N
7W	El Venadito	Olmito Silty Clay	Severe: Percs Slowly	0.06 - 0.20	60 - 120	N
		Laredo Silty Clay Loam (0-1% Slopes)	Moderate: Percs Slowly	0.06 - 0.20	36 - 120	N
8W	Carricitos-Landrum	Laredo Silty Clay Loam (0-1% Slopes)	Moderate: Percs Slowly	0.06 - 0.20	36 - 120	N
		Olmito Silty Clay	Severe: Percs Slowly	0.06 - 0.20	60 - 120	N
		Rio Grande Silty Loam	Severe: Floods	0.63 - 2.0	> 63	N
9W	El Calaboz	Laredo Silty Clay Loam (0-1% Slopes)	Moderate: Percs Slowly	0.06 - 0.20	36 - 120	N
10W	Iglesia Antigua	Olmito Silty Clay	Severe: Percs Slowly	0.06 - 0.20	60 - 120	N
11W	Palmer	Laredo Silty Clay Loam (0-1% Slopes)	Moderate: Percs Slowly	0.06 - 0.20	36 - 120	N
		Benito Clay	Severe: Percs Slowly; Wet	< 0.06	60 - 120	N
12W	Unknown (Mita 2)	Laredo Silty Clay Loam (0-1% Slopes)	Moderate: Percs Slowly	0.06 - 0.20	36 - 120	N
		Tiocono Clay	Severe: Floods; Percs Slowly	< 0.06	60 - 120	N
13W	O Unknown (Santa Rosa)	Raymondville Clay Loam (Saline)	Severe: Percs Slowly	0.06 - 0.20	60 - 120	N
		Raymondville Clay Loam	Severe: Percs Slowly	0.20 - 0.63	60 - 120	N
14W	W	Raymondville Clay Loam	Severe: Percs Slowly	0.20 - 0.63	60 - 120	N
		Racombes Sandy Clay Loam	Severe: Floods	0.63 - 2.0	60 - 120	N
		Willacy Fine Sandy Loam (0-1% Slopes)	Slight	2.0 - 6.3	> 74	Y
		Hidalgo Sandy Clay Loam	Slight	0.63 - 0.20	60 - 120	N
		Hidalgo Fine Sandy Loam (0-1% Slopes)	Slight	0.63 - 2.0	> 15	N
15W	R Unknown (Santa Rosa)	Mercedes Clay (0-1% Slopes)	Severe: Percs Slowly	< 0.60	60 - 120	N
		Raymondville Clay Loam	Severe: Percs Slowly	0.20 - 0.63	60 - 120	N
16W	X Unknown (La Feria)	Raymondville Clay Loam	Severe: Percs Slowly	0.20 - 0.63	60 - 120	N
17W	El Venadito	Hidalgo Sandy Clay Loam	Slight	0.63 - 0.20	60 - 120	N
		Benito Clay	Severe: Percs Slowly; Wet	< 0.06	60 - 120	N
		Raymondville Clay Loam	Severe: Percs Slowly	0.20 - 0.63	60 - 120	N

Soils Summary (Sub-Area H)

Colonia PUB Designation	Colonia	Soils Designation	Degree and Kind of Limitation for Septic Tank Absorption Fields	Permeability (in/hr)	Depth to Seasonal High Water Table (In)	Suitable for Absorption Trench On-Site Disposal (Y/N)
1H	Las Palmas	Hidalgo-Urban Land Complex	-	-	60 - 120	N
		Hidalgo Sandy Clay Loam	Slight	0.63 - 0.20	60 - 120	N
		Raymondville Clay Loam	Severe: Percs Slowly	0.20 - 0.63	60 - 120	N
		Raymondville-Urban Land Complex	-	-	36 - 72	N
		Racombes Soils and Urban Land	-	-	60 - 120	N
		Racombes Sandy Clay Loam	Severe: Floods	0.63 - 2.0	60 - 120	N
2H	Lago Subdivision	Willacy Fine Sandy Loam (0-1% Slopes)	Slight	2.0 - 6.3	> 74	Y
		Chargo Silty Clay	Severe: Percs Slowly	0.06 - 0.20	24 - 36	N
		Laredo Silty Clay Loam (0-1% Slopes)	Moderate: Percs Slowly	0.06 - 0.20	60 - 120	N
3H	26	Tiocano Clay	Severe: Floods; Percs Slowly	< 0.06	> 74	Y
		Racombes Sandy Clay Loam	Severe: Floods	0.63 - 2.0	60 - 120	N
		Willacy Fine Sandy Loam (0-1% Slopes)	Slight	2.0 - 6.3	> 74	Y
		Hidalgo Fine Sandy Loam (0-1% Slopes)	Slight	0.63 - 2.0	60 - 120	N
4H	Lasana	Raymondville Clay Loam	Severe: Percs Slowly	0.20 - 0.63	60 - 120	N
		Racombes Sandy Clay Loam	Severe: Floods	0.63 - 2.0	60 - 120	N
		Rio Clay Loam	Severe: Floods; Percs Slowly	0.63 - 2.0	36 - 72	N
5H	Rice Tracts	Tiocano Clay	Severe: Floods; Percs Slowly	< 0.06	> 74	Y
		Laredo Silty Clay Loam (0-1% Slopes)	Moderate: Percs Slowly	0.06 - 0.20	60 - 120	N
6H	Leal Subd. (Motes & Bounds)	Harlingen Clay	Severe: Percs Slowly	0.06	60 - 120	N
7H	Laguna Escondido Heights	Olmite Silty Clay	Severe: Percs Slowly	0.06 - 0.20	60 - 120	N
		Raymondville Clay Loam	Severe: Percs Slowly	0.20 - 0.63	60 - 120	N

Soils Summary (Sub-Area E)

Colonia PUB Designation	Colonia	Soils Designation	Degree and Kind of Limitation for Septic Tank Absorption Fields	Permeability (In/hr)	Depth to Seasonal High Water Table (In)	Suitable for Absorption Trench On-Site Disposal (Y/N)
1E	La Coma Del Norte	Benito Clay	Severe: Percs Slowly; Wet	< 0.06	60 - 120	N
		Harlingen Clay	Severe: Percs Slowly	0.06	60 - 120	N
		Laredo-Olmite Complex	Severe: Percs Slowly	0.06 - 0.20	60 - 120	N
2E	Lozano	Raymondville Clay Loam	Severe: Percs Slowly	0.20 - 0.63	60 - 120	N
		Lyford Sandy Clay Loam	Moderate: Percs Slowly; Wet	0.63 - 2.0	36 - 72	N
3E	Latina Ranch	Lyford Sandy Clay Loam	Moderate: Percs Slowly; Wet	0.63 - 2.0	36 - 72	N
		Willamar Soils	Severe: Percs Slowly	0.63 - 2.0	36 - 72	N
		Defina Fine Sandy Loam	Severe: Percs Slowly	2.0 - 6.3	60 - 72	N
		Lozano Fine Sandy Loam	Severe: Percs Slowly	2.0 - 6.3	36 - 72	N
		Willacy Fine Sandy Loam	Slight	2.0 - 6.3	> 74	Y
4E	Laureles	Harlingen Clay	Severe: Percs Slowly	0.06	60 - 120	N
5E	Del Mar Heights	Lomalta Clay	Severe: Percs Slowly	0.06	48 - 120	N
		Sejita Silty Clay Loam	Severe: Floods; Wet	0.20 - 0.63	20 - 48	N
6E	Orason Ac/Chula Vista/Shoe.	Chargo Silty Clay	Severe: perc Slowly	0.06 - 0.20	24 - 36	N
		Lomalta Clay	Severe: Percs Slowly	0.06	48 - 120	N
		Harlingen Clay (Saline)	Severe: Shrink-Swell	0.06	60 - 120	N
7E	Las Yescas	Lozano Fine Sandy Loam	Severe: Percs Slowly	2.0 - 6.3	36 - 72	N
8E	Unknown	Benito Clay	Severe: Percs Slowly; Wet	0.06	60 - 120	N
		Olmite Silty Clay	Severe: Percs Slowly	0.06 - 0.20	60 - 120	N
9E	Glenwood Acres Subd.	Benito Clay	Severe: Percs Slowly; Wet	0.06	60 - 120	N
10E	Unknown (Del Mar II)	Lomalta Clay	Severe: Percs Slowly	0.06	48 - 120	N
		Sejita Silty Clay Loam	Severe: Floods; Wet	0.20 - 0.63	20 - 48	N
11E	Los Cuates	Laredo Silty Clay Loam (0-1% Slopes)	Moderate: Percs Slowly	0.06 - 0.20	60 - 120	N
		Laredo Silty Clay Loam ( 1-3% Slopes)	Moderate: Percs Slowly	0.06 - 0.20	60 - 120	N
		Tocano Clay	Severe: Floods; Percs Slowly	< 0.06	> 74	Y
		Laredo-Olmite Complex	Severe: Percs Slowly	0.06 - 0.20	60 - 120	N
12E	25	Benito Clay	Severe: Percs Slowly; Wet	0.06	60 - 120	N
13E	Claneros (Limon)	Benito Clay	Severe: Percs Slowly; Wet	0.06	60 - 120	N

The Willacy-Racombe association soils are nearly level to gently sloping, well-drained fine sandy loams and sandy clay loams. This association makes up about 7% of the county. About 10% to 15% of this association is affected by a seasonal high water table and slight to moderate salinity.

The Lyford-Raymondville-Lozano soil association can be described as nearly level, well-drained and moderately well-drained sandy clay loams, clay loams, and fine sandy loams. This association occupies about 4% of the county. A seasonal high water table is at a depth of 2 to 6 feet in about 40% to 50% of the acreage in the association. Approximately 30% of this association is affected by moderate to severe salinity.

The Hidalgo-Raymondville association can be described as nearly level to gently sloping, well-drained and moderately well-drained sandy clay loams and clay loams. This association makes up about 4% of the county. A seasonal high water table is in 15% to 20% of this association.

The Willacy-Raymondville soil association is described as nearly level to gently sloping, well-drained and moderately well-drained fine sandy loams and clay loams. This soil association comprises about 4% of the county. Approximately 10% of this association is irrigated and less than 5% is affected by a seasonal high water table.

The Raymondville association soils are described as nearly level, moderately well-drained clay loams. These soils occupy small irregularly shaped areas of nearly level plains that are broken by slight rises. The Raymondville association makes up about 4% of Cameron County. Much of this association lacks adequate surface drainage and a seasonal high water table exists at 2 to 10 feet in irrigated areas.

The Harlingen-Benito association soils can be described as level to nearly level, moderately well-drained to poorly drained. These soils make up about 8% of the county. This association occupies broad areas of slightly depressed areas that lack adequate surface drainage and are flooded for several days after heavy rains. Generally this association has a water table below 5 feet.

The Harlingen association soils are described as level and nearly level, and nearly level, moderately well-drained clays that occupy broad plains broken by slight depressing drainages. This association makes up about 7% of the county. The water table in the association is generally below 5 feet.

The Mercedes association soils occupy broad plains that are level to gently sloping. The soils are moderately well-drained clays that make up about 5% of the county. The water table generally is at a depth below 5 feet.



The Mustang-Coastal dune association is best described as nearly level to steep, poorly drained fine sands and sand dunes. These soils are found in a narrow band along the Gulf of Mexico coast. This soil association consists of active to partially stabilized windblown sands that are up to 30 feet above sea level.

### 7.3.2 Hydrological Elements

Cameron County is located in the West Gulf Coast section of the Coastal Plain Physiographic province. The major portion of the county is gently rolling to flat, gradually sloping toward the coast and the Rio Grande. The county is crossed by many sinuous resacas, abandoned former courses of the Rio Grande and its tributaries. Other major waterways in the county include the Arroyo Colorado, Resaca de Rancho Viejo and Resaca de los Cuates. All of these waterways eventually empty into the Laguna Madre or any of several lakes on bays along the Laguna Madre.

Cameron County abuts eight TWC Designated Water Quality Segments.

These segments are:

- Segment 2201: Arroyo Colorado Tidal - from the confluence with the Laguna Madre to a point 100 meters (110 yards) downstream of Cemetery Road south of Port Harlingen.
- Segment 2202: Arroyo Colorado Above Tidal - from a point 100 meters (110 yards) downstream of Cemetery Road south of Port Harlingen to FM 2062 in Hidalgo County. Segment 2202 is Water Quality Limited.
- Segment 2301: Rio Grande Tidal - from the confluence with the Gulf of Mexico to a point 10.8 kilometers (6.7 miles) downstream of the International Bridge in Cameron County.
- Segment 2302: Rio Grande Below Falcon Reservoir - from a point 10.8 kilometers (6.7 Miles) downstream of the International Bridge in Cameron County to Falcon Dam in Starr County.
- Segment 2491: Laguna Madre
- Segment 2493: South Bay
- Segment 2494: Brownsville Ship Channel
- Segment 2501: Gulf of Mexico

The designated uses and water quality criteria of each Cameron County segment are shown in Table 7-2. All segments are classified by the TWC and EPA as "effluent limited" which indicates that the water quality of the segment is not currently considered to be severely degraded, designated segment uses are not threatened, and the assimilative capacity of the segment is relatively high. With the exception of the Brownsville Ship Channel, all segments are considered

Table 7-2

**Designated Uses and Water Quality Criteria of  
Cameron County Segments**

Segment	Segment Name	Uses	Criteria
2201	Arroyo Colorado Tidal	Contact Recreation High Qual Aq. Life.	D.O. <sup>a/</sup> 40. mg/L pH 6.5-9.0 fecal coli. <sup>b/</sup> 200/100 ml Temp. 95°
2202	Arroyo Colorado Above Tidal	Contact Recreation Intermediate Aq. Habitat	Cl <sup>-c/</sup> 1,200 mg/L SO <sub>4</sub> <sup>= c/</sup> 1,000 mg/L TDS <sup>c/</sup> 4,000 mg/L D.O. <sup>a/</sup> 4.0 mg/L pH 6.5-9.0 fecal coli. <sup>b/</sup> 200/100 ml Temp. 95°
2301	Rio Grande Tidal	Contact Recreation Excep. Qual Aq. Life	D.O. <sup>a/</sup> 5.0 mg/L pH 6.5-9.0 fecal coli. <sup>b/</sup> 200/100 ml Temp. 95°
2302	Rio Grande Below Falcon R.	Contact Recreation High Qual. Aq. Life Public Water Supply	Cl <sup>-a/</sup> 270 mg/L SO <sub>4</sub> <sup>= c/</sup> 350 mg/L TDS <sup>c/</sup> 880 mg/L D.O. <sup>a/</sup> 5.0 mg/L pH 6.5-9.0 fecal coli. <sup>b/</sup> 200/100 ml Temp. 95°
2491	Laguna Madre	Contact Recreation Excep. Qual Aq. Life	D.O. <sup>a/</sup> 5.0 mg/L pH 6.5-9.0 fecal coli. <sup>b/</sup> 14/100 ml Temp. 95°
2493	South Bay	Contact Recreation Excep. Qual Aq. Life	D.O. <sup>a/</sup> 5.0 mg/L pH 6.5-9.0 fecal coli. <sup>b/</sup> 14/100 ml Temp. 95°
2491	Brownsville Ship Channel	Non-contact Recreation Excep. Qual Aq. Life	D.O. <sup>a/</sup> 5.0 mg/L pH 6.5-9.0 fecal coli. <sup>b/</sup> 2,000/100 m Temp. 95°
2501	Gulf of Mexico	Contact Recreation Excep. Qual Aq. Life	D.O. <sup>a/</sup> 5.0 mg/L pH 6.5-9.0 fecal coli. <sup>b/</sup> 14/100 ml Temp. 95°

<sup>a/</sup> Mean over 24-hour period

<sup>b/</sup> Thirty-day geometric mean not to exceed.

<sup>c/</sup> Annual average not to exceed

Source: TWC, 1990

suitable for contact recreation. The tidal portion of the Rio Grande, Laguna Madre, South Bay, Brownsville Ship Channel, and the Gulf of Mexico are all considered to possess habitats and conditions suitable for "Exceptional Quality Aquatic Life" and, as such, have an average dissolved oxygen (D.O.) criteria of 5.0 mg/L. The tidally influenced portion of the Arroyo Colorado and the Rio Grande Above Tidal are considered to be indicative of a "High Quality Aquatic Life" habitat and also have a 5.0 mg/L minimum D.O. criteria. Because the Arroyo Colorado Above Tidal receives the wastes from a large number of municipal and industrial dischargers as well as significant quantities of irrigation return flow, water quality and habitat are considered to support only "Moderate Quality Aquatic Life." As a result the D.O. criteria for the Arroyo Colorado Above Tidal is only 4.0 mg/L.

The Texas Water Commission, Texas Parks and Wildlife Department, U.S. Geological Survey, and International Boundary Water Commission routinely sample portions of the Rio Grande, Arroyo Colorado, Laguna Madre and Gulf of Mexico. In addition, several studies have been performed by State and local Universities. The Lower Rio Grande Valley Development Council (LRGVDC) commissioned a number of special studies in support of the areawide water quality management planning process conducted under Section 208 of the Federal Water Pollution Control Act of 1972 (LRGVDC 1977-78). Most of this data is contained in the Texas Natural Resource Information Service's (TNRIS) statewide monitoring data base (SMN).

In August 1976, an Intensive Survey was conducted by the TDWR for the tidal portion of the Arroyo Colorado. Results of the survey indicate that the stream has a low assimilative capacity during low-flow conditions. Nutrient and oxygen-demanding material loading from municipal dischargers were determined to be responsible for eutrophic conditions.

A draft Waste Load Evaluation (WLE) is available for the Arroyo Colorado (TDWR, 1985). Waste load projection were made for existing dischargers for the year 2000 and dissolved oxygen conditions simulated using a calibrated and verified version of the QUAL-TX water quality model. Effluent limits recommended in the WLE in order to maintain the 4.0 mg/L D.O. standard were, in general, at secondary treatment.

Waste load evaluations are not currently available for the Brownsville Ship Channel or the Rio Grande. The QUAL-TX Model will be applied to these segments as a part of this planning study. Treatment levels necessary to maintain designated uses and minimum water quality standards will be determined for each existing and proposed discharge under future conditions.

### 7.3.3 Climatic Elements

The Cameron County climate is subtropical in nature and is characterized by dry, mild winters and hot humid summers. The general weather patterns in Cameron County vary from the tropical maritime air masses during the warmer months to the continental or polar air masses during the colder months.

The prevailing winds are southeasterly to south-southeasterly for a majority of the year and north-northwesterly during December (Orton et al., 1977).

The fact that Cameron County borders the Gulf of Mexico and progresses westward, weather conditions vary somewhat from east to west. Temperature are moderated by the Gulf of Mexico; consequently, freezing temperatures are less frequent and precipitation increases as the proximity to the Gulf of Mexico decreases.

The following climatic data was recorded in Harlingen, Texas from 1931-1969 (Orton, 1977). A summary of climatic data is presented on Table 7-3. The average annual rainfall is about 26 inches, most of which occurs in September due to heavy rains attributed to tropical depressions, tropical storms or hurricanes. Another annual period of peak precipitation occurs in May and June which recorded 3.18 and 2.49 inches of rain, respectively, during the survey period (Orton, 1977). Conversely, March typically yields the least rainfall with 0.95 inches (Orton, 1977).

Infrequently, snow or sleet does fall in January; however, amounts are typically too slight to be accurately measured. Temperatures of 32°F or below do occur; however, not on an annual basis and the county enjoys a 341-day warm season (Orton, 1977). The average daily maximum temperature for Cameron County from 1931-1969 varied from 70.9 (°F) in January to 96.7 (°F) in August. Historically, severe freezes have caused considerable damage to the vegetable and citrus crops and were documented in 1949, 1951, 1962 (Orton, 1977), 1983 and 1989.

Typically the free-water evaporation exceeds precipitation by 32 to 36 inches annually, the higher value being toward the coast (Orton, 1977).

### 7.3.4 Biological Elements

#### 7.3.4.1 Vegetation

Cameron County is located within an area that is bisected by the Gulf Prairie and Marsh Vegetation Area and South Texas Plains Vegetational Area described by Gould (1975). The study area is level to gently sloping and bisected by the Arroyo Colorado, and several other small tributaries flowing into the Laguna Madre, and bordered by the Rio Grande which flows into the open Gulf of

Table 7-3  
 Summary of Climatic Data For  
 Cameron County, Texas Recorded at  
 Harlingen, Texas from 1931-1969

Month	Average Daily Maximum (°F)	Average Monthly Lowest Temperature (°F)	Precipitation (Inches)
January	70.9	31.4	1.43
February	74.5	34.8	1.22
March	79.0	39.4	0.95
April	85.9	49.4	1.47
May	90.0	58.5	3.18
June	93.7	66.2	2.49
July	96.0	69.5	1.71
August	96.7	68.9	3.04
September	92.3	62.1	4.80
October	87.1	51.4	2.56
November	78.9	39.9	1.43
December	73.0	34.0	1.57
<b>Year</b>	<b>84.8</b>	<b>-----</b>	<b>25.85</b>

7-14

\* Source USDA; Cameron County Soil Survey

Mexico. Elevations in Cameron County range from sea level to approximately 70 feet in the western portions of the county.

Gould (1975) describes distinct differences in climax plant communities throughout the area of Cameron County located within the South Texas Plains Vegetational Area. Grasses characteristic of the sandy loam soils include seacoast bluestem, species of *Setaria*, longspike silver bluestem, big sandbur, and tanglehead. Clays and clay loams are characterized by longspike silver bluestem, Arizona cottontop, buffalo grass, and curly mesquite. The lower elevation saline areas are characterized by gulf cordgrass, seashore saltgrass, and switchgrass (Gould, 1975).

The Gulf Prairie and Marsh, as described by Gould, is typically separated into two major divisions: the Coastal Prairie - a nearly-level, slowly-drained plain less than 150 feet in elevation; and Coastal Marsh - the low west marsh area located immediately adjacent to the coast.

Gulf Prairie climax vegetation is primarily comprised of tall bunch grasses, including big bluestem, seacoast bluestem, Indiangrass, eastern gamagrass, and several species of *Panicum*, among others. The marsh areas typically support salt-tolerant species such as *Carex*, *Cyperus*, *Juncus*, *Scripus*, and several species of cordgrass, including *Spartina* and marsh millet.

Biotic communities within the Rio Grande Valley have recently been further divided into 11 distinct areas within the Tamaulipan Biotic Province (as described by Blair, 1950). Five of these communities, located within the study area, are described below (per USFWS Biological Report 88(36); November, 1988):

**Mid-Valley Riparian Woodland** - This is essentially a bottomland hardwood site, with stands of cedar elm, Berlandier ash (*Fraxinus berlandieriana*), and sugar hackberry (*Celtis laevigata*) mixed with mesquite/granjeno. The result is a dense, tall, canopied forest and greater availability of water and wildlife foods. This habitat is preferred by many rare birds; orioles (*Icterus spp.*), chachalacas (*Ortalis vetula*), and green jays (*Cyanocorax yncas*) may reach their greatest density in this habitat. Resacas in this habitat provide aquatic ecosystems that protect a unique group of Tamaulipan biota.

**Sabal Palm Forest** - The 149-ha (367 acre) USFWS tract in this community is known as "Boscaje de la Palma" and is located in the southmost bend of the Rio Grande near Brownsville. Remnant stands of Mexican palmettos (*Sabal mexicana*) - locally called sabal palm - found in a 1,418-ha (3,500-acre) area represent a remnant of a former 16,200-ha (40,000-acre) community. Palms were so prevalent that early Spanish explorers called the Rio Grande "Rio de las Palmas" (Crosswhite, 1980). These stands are best described as palm-dominated, brush tracts with

Mexican palmettos, tepeguaje (*Leucaena pulverulenta*), anacua, and Texas ebony as major woody associated. Characteristic fauna include ocelot, jaguarundi, lesser yellow bat (*Lasiurus ega*), hooded oriole (*Icterus cucullatus*), speckled racer (*Drymobius margaritiferus*), and northern cat-eyed snake (*Leptoderia septentrionalis*).

Clay Loma/Wild Tidal Flats - Three different communities form a "miniature ecosystem" of wooded islands in tidal flats that are periodically inundated by water from South Bay and the Gulf of Mexico. Lomas are formed from wind-blown silt or clay particles, originally deposited in tidal flats by periodic flooding from the Rio Grande. When flats are dry and barren, prevailing winds deposit particles on dunes, which are normally covered with woody vegetation. Dunes may grow to 9m (30 ft) above surrounding tidal flats. Rains and flooding can erode outer edges of the lomas. When wind or storm tides retreat, loma building begins again. Characteristic vegetation includes fiddlewood (*Citharexylum brachyanthum*) and Texas ebony on the lomas; borrichia (*Borrichia frutescens*) and salicornia (*Salicornia spp.*) on the flats; and black mangrove (*Avicennia nitida*) on South Bay. Representative vertebrates are the Texas tortoise (*Gopherus berlandieri*), long-billed curlews (*Numenius americanus*), and a unique hypersaline-tolerant population of oysters (*Ostrea equestris*).

Mid-Delta Thom Forest - This community contains a mesquite and granjeno association mixed with Texas ebony, anacua, and brazil (*Condalia hookeri*) and was once an extensive thicket that covered most of the Rio Grande delta. There is <5% of the original acreage left, mostly in fence rows, highway rights-of-way, canals, and ditch banks. Remnant tracts are small (normally <40 ha [ $<100$  acres]) and scattered. Shrubs in this habitat form a tight interwoven canopy of 4-6m (15-20 ft). The mid-delta thom forest was used historically for nesting by white-winged doves.

Coastal Brushland Potholes - The southern edge of the Coastal Brushland Pothole biotic community extends into Cameron County. Here, the Gulf's influence creates a stable, saline microclimate which differs from that of other inland wetlands. In this area, moving sand dunes cover vegetation, subsequently uncover it and often leave depressions. When these depressions hold water, they provide excellent habitat for water fowl and the brushy perimeter may be utilized by ocelot and jagurundi.

#### 7.3.4.2 Wildlife

Cameron County, located in extreme southeastern Texas, lies within the Matamorán District of the Tamaulipan Biotic Province described by Blair (1950). The vertebrate fauna of the Tamaulipan Province is represented by a mixture of species (including a considerable element of Neotropical species) from the Texan, Kansan, Austroriparian, and Chihuahuan provinces (Blair, 1950). The

major wildlife habitats in the Tamaulipan Province are synonymous with the vegetative types discussed previously.

Approximately 700 species of vertebrates have been identified in the Matamorán District of the Lower Rio Grande Valley, a number of which are not found elsewhere in the U.S. (USFWS, 1988). The wide range of habitat types provides the study area with a diverse array of vertebrate fauna that includes subtropical, southwestern desert, prairie, coastal marshlands, eastern forest, and marine species.

#### 7.3.4.3 Aquatic, Estuarine, and Marine Ecology

The study area is characterized by a wide range of aquatic, estuarine, and marine ecosystems. Significant habitat include the hypersaline marine environment found in the Lower Laguna Madre; the Lower Arroyo Colorado and Rio Grande Estuaries; and the Riverine habitats of the Arroyo Colorado and the Rio Grande. A detailed discussion of each of these habitats was developed in a report completed in March 1989 for the Rio Grande Municipal Water Authority and the Public Utilities Board of Brownsville "Environmental Inventory and Issues Report Rio Grande Valley Water Conservation Project". The following section is a reprint from this report.

##### Lower Laguna Madre

High temperature and high evaporation, combined with a low annual rainfall, favor the production of hypersaline waters. There is an almost total lack of freshwater inflow into the lower Laguna Madre, except for drainage water from the Arroyo Colorado. As a consequence, the number of species that inhabit the area is severely limited. However, the number of individual members of each species is very high and the Laguna has a disproportionately high level of productivity, as compared with other Texas bays. The limited number of species results in a simplified food chain, in which benthic plants assume a more important role than phytoplankton. Most of the animals probably obtain primary nutrients via an abbreviated detrital food chain, which results in a more efficient transfer of carbon to higher trophic levels. This efficient recycling of detrital constituents depends upon the retention of detritus within the Laguna, associated with low tidal flushing (Pulich 1980).

The lower Laguna Madre supports five species of seagrasses. Each is adapted to specific ecological conditions, of which salinity, temperature and light are the most significant. The physical requirements and limitations of each species is shown in Table 7-4. In general, shoal grass is the most abundant of the five species. It can withstand the greatest salinity fluctuations, particularly hypersalinity. While manatee grass and turtle grass prefer the areas around inlets and passes,



shoal grass is widespread in more restricted areas where other grasses do not grow. It is considered the most desirable species of seagrass to maintain in the Laguna Madre because it provides spawning areas for fish and food for waterfowl (Espey Huston, 1981).

Seagrass ecosystems are recognized as some of the most productive in the world. While direct grazing on their leaves is not common, grazing on the epiphytic organisms they support does occur. Decaying leaves settle in the sediment and are later consumed as detritus. They also aid in the maintenance of an active sulphur cycle and the leaves slow water currents near the sediment surface. Together with the root and rhizome systems, which bind the sediment, they inhibit erosion, enabling rapid recovery of the ecosystem following severe storms. In general, there is a positive correlation between sediment stability and invertebrate diversity (Espey Huston, 1981).

The zooplankton include rotifers, cladocerans, copepods, coelentrates, ctenophores and larvae of molluscs and crustaceans. The calanoid copepod *Acartia tonsa* tends to dominate the zooplankton in inshore areas as a result of its tolerance of wide variations in temperature and salinity. In brackish water it is replaced by freshwater copepods, cladocerans and rotifers. Benthic species that are important components of the food chain include the polychaete *Nereis pelagica occidentalis*, the amphipod *Elasmapus* sp., the pistol shrimp *Crangon heterochaelis* and the blue crab *Callinectes sapidus* (Espey Huston, 1981).

Nekton species of the lower Laguna Madre resemble those found in other Texas bays. In a 1962 study, 77 species of fish were reported. Of these 5 percent were restricted to the brackish waters of the Arroyo Colorado. Numerous species, including redfish, white shrimp, bay anchovies and spotted seatrout utilize this brackish area as both a nursery and foraging ground. The distribution of juvenile shrimp is salinity dependent. Brown shrimp prefer salinities of 10-30 ppt, and are most abundant when salinities are above 20 ppt. White shrimp prefer lower salinity and are largely restricted to the brackish Arroyo Colorado and other channels. In general, nekton in the Laguna Madre exhibit three different reproductive cycles. Many species are estuarine dependent, with adults spawning in the Gulf of Mexico and young organisms being carried into the bay to mature.

The most important sport and commercial species in the inshore areas are the red drum, spotted seatrout and black drum. The Laguna Madre is the preferred habitat for the black drum, which feeds mainly on bivalves concentrated in the seagrass beds. Red drum and spotted seatrout each made up approximately 40 percent of the commercial catch in the lower Laguna Madre in the mid 1970s. Both feed on a variety of crustaceans and to some extent on small fish. Seatrout are tolerant of warm temperatures and high salinity. In one study (Shew *et al* 1981) a positive

correlation between salinity and seatrout size was found. Other commercial species of lesser importance to this area include oysters, finfish, sheepshead, flounder and Atlantic croaker.

The extensive mud flats along the Laguna Madre are the chief feeding ground for shore birds and some wading birds. Geese, pintails and other waterfowl use them as nesting areas. They are an important contributor to the food chain of many marine organisms, used by crab, shrimp and other organisms when inundated. The normal tide of 5 inches covers part of the flats and three or four times a year, winter wind tides inundate all or most of the area.

Of the approximately 650 bird species in the U.S., 380 occur along the Texas coastal zone. Many, such as the Louisiana heron and the reddish egret, depend heavily on the estuarine community, whereas the terns are also part of the beach and marine community. The Laguna Madre provides the wintering ground for 78 percent of the world's redhead ducks, which feed primarily on shoal grass (Shew *et al* 1981).

#### Lower Arroyo Colorado

The Arroyo Colorado is one of the major arteries in the Rio Grande Valley drainage system and receives much of the municipal, agricultural and industrial waste of the area. Small ox-bow lakes indicate that at one time it was an arm of the Rio Grande, branching from the river at a point below the city of Mission. The Arroyo Colorado is a deep channel cut through the Beaumont delta plain, and has a small delta at its mouth. In the late 1940s, the lower 25 miles was dredged to a depth of 14 feet to accommodate barge traffic to the Port of Harlingen. During this process some curves in the original river bed were by-passed, leaving shallow ox-bow areas. For the first 7 miles inland, the old bed was by-passed completely; a new channel runs almost due east to the Gulf Intracoastal Waterway, approximately 21 miles north of Port Isabel. It serves as a floodway, an inland waterway and as a recreational area for boating and fishing (Bryan 1971).

The lower Arroyo Colorado is one of the very few brackish water areas in the Lower Laguna Madre and provides a nursery ground for marine species of the area. Typically, the salinity pattern shows a gradation from lower to higher saline water both with increasing depth and with distance downstream. From surface to bottom it can vary by as much as 29.4 ppt. However, this pattern can be severely disrupted during major storm activity. For instance, following Hurricane Beulah salinity levels in the entire Arroyo Colorado approached that of freshwater. There is also an inverse correlation between salinity and dissolved oxygen. In general, tides are highest in fall and spring and lowest during winter and summer. In 1969 the tide level at mile 8 fluctuated 18 inches. Tides are also greatly influenced by prevailing winds (Bryan 1971).

Table 7-4  
Limits of Tolerance of Texas Seagrasses

	Optimum salinity (ppt)	Limits of salinity (ppt)	Optimum temperature
<i>Thalassia testudinum</i> (turtle grass)	37.0	to 60	18-32°C growth 29°C max prod.
<i>Syringodium filiformis</i> (manatee grass)	<36.0	to 40	23-25°C flowers 26°C fruits
<i>Halodule wrightii</i> (shoal grass)	35 to 44	to <72	
<i>Halophila Engelmannii</i> (halophila)	37.0	23 to 50	
<i>Ruppia maritima</i> (widgeon grass)	<25.0	0 to 40/60 >30.0 no flowering	15-20°C germ. 20-25°C growth

Espey, Huston and Associates, Inc. *Final Environmental Report: Proposed Deepwater Channel and Multipurpose Terminal Construction and Operation near Brownsville, Texas*, Volume 6, appendix H, I and J, 1981.

A study performed by C.E. Bryan at the University of Texas in 1971 showed that the most numerous economically important species were juvenile menhaden (*Brevoortia* sp.), redfish (*Sciaenops ocellata*) and white shrimp (*Penaeus setiferus*). Brown shrimp (*Penaeus aztecus*) and the blue crab (*Callinectes sapidus*) were found in the area to a lesser degree. The spotted sea trout (*Cynoscion nebulosus*) was the most abundant adult species taken. Less abundant fish, concentrated in the lower 12 miles, were redfish, black drum (*Pogonias cromis*), sheepshead (*Archosargus probatocephalus*) and southern flounder (*Paralichthys lethostigma*). Between October, 1965 and August, 1966 water flow into the Arroyo Colorado at Mercedes, Texas averaged 92 cubic feet per second, with a peak flow of 943 cfs and a minimum flow of 24 cfs. During the 1967 flood following Hurricane Beulah, the flow reached an estimated 55,400 cfs (Bryan 1971).

Fish kills are common in the Arroyo Colorado. During the sampling period of the Bryan study, eight kills were investigated. Most of the mortalities occurred between June and September, and were associated with high salinity and dissolved oxygen levels close to zero. DDT sampling revealed that the Arroyo Colorado had the highest level of any area sampled on the Texas coast. Dieldrin and Endrin were also found in many of the samples. This could explain the decline in numbers of spotted sea trout observed during the 1960s. By 1970 there was a tenfold increase in the number of juvenile spotted sea trout in the lower Laguna Madre as compared with the previous year, and this was attributed to reduced pesticide levels in the Arroyo Colorado. Tarpon, which were numerous in the early 1950s, have also disappeared (Bryan 1971).

## Rio Grande Estuary

In 1969 the Texas Parks and Wildlife Department conducted a study in the tidal water section of the Rio Grande. During this study period dissolved oxygen levels ranged from 0.3 to 12.2 mg/L. It was higher during winter months and generally higher at the surface than at the bottom. Salinity also showed a gradation from surface to bottom; at the mouth of the river a freshwater override was evident in surface samples. At river mile 12 some bottom water contained traces of salinity, but all surface samples reflected river flow and registered zero.

Marine species appeared to use the river as a nursery or feeding ground, but not as a spawning area. The most important commercial invertebrate found in the tidal Rio Grande was the white shrimp (*Penaeus setiferus*). Brown shrimp (*P. aztecus*) were much less frequent. A few blue crabs (*Callinectes sapidus*) were present at most stations, but did not appear to use the area as a nursery ground. The most important marine fish was the Atlantic croaker, which used the entire area as a nursery. Adult spotted sea trout, redfish, black drum and snook were important commercial and sportfish found near the mouth of the river (Breuer 1970).

## Riverine Environments

An inventory of fish caught downstream from Falcon dam in the Rio Grande in 1954 is shown in Table 7-5 (Trevino 1955). Trevino's study extended from the mouth of the river to the Pecos. The river water was generally muddy, with no significant amounts of aquatic vegetation. The distribution of species indicates that, at that time, brackish water forms are replaced by freshwater species just east of Brownsville.

In addition to fish, two species of shrimp were reported in the freshwater stretches of the river within the study area. *Macrobrachium acanthurus* and *M. ohione* were reported as far upstream as the Hidalgo/Starr County line.

### 7.3.4.4 Wetlands and Unique Areas

Wetlands are defined as those areas which are saturated or inundated by ground or surface water at a frequency sufficient to support, and under normal circumstances, do support prevalence of vegetation typically adapted to saturated conditions. Wetlands are usually a transition area between aquatic and terrestrial environments. A description of significant wetland habitat from the Environmental Inventory and Issues Report follows :

Table 7-5  
Fish Populations of the Rio Grande

Species	Distribution
<i>Lepisosteus spatula</i>	Starr County, including Falcon Lake
<i>L. osseus</i>	Locally abundant, prefer moderately moving water
<i>Dorosoma petenense</i>	Found at every station
<i>D. cepedianum</i>	Found at every station
<i>Astyanax fasciatus</i>	The most widespread and common fish collected
<i>Carpiodes carpio</i>	Numerous everywhere in moderate currents
<i>Hybopsis aestivalis</i>	Caught throughout study area
<i>Notropis jemezianus</i>	One of the most prevalent species taken
<i>N. braytoni</i>	Caught upstream of Roma
<i>N. lutrensis</i>	West of Cameron County one of the most common fish
<i>N. buchananii</i>	Upstream of western Hidalgo County in fast moving water
<i>Hybognathus placita</i>	Common throughout
<i>Ictalurus lupus</i>	Spotty distribution; found at Roma
<i>I. furcatus</i>	Found in Cameron and Starr counties
<i>Cyprinodon variegatus</i>	Common in side pools and shallow water
<i>Gambusia affinis</i>	Common throughout study area
<i>Mollienisia formosa</i>	Not numerous, but widespread
<i>M. latipinna</i>	Caught at one station below Hidalgo
<i>Mugil cephalus</i>	Abundant in Cameron County, less common upstream
<i>Menidia beryllina</i>	Common throughout close to shore
<i>Micropterus salmoides</i>	Immature samples found near Roma
<i>Lepomis macrochirus</i>	Hidalgo and Starr counties
<i>Aplodinotus grunniens</i>	Found throughout area, but not at every station
<i>Chichlasoma cyanoguttatum</i>	Most common upstream from Hidalgo
<i>G. dormitator</i>	Few specimens throughout area, most caught 9 miles east of Brownsville

Trevino, D.B. *The Ichthyofauna of the Lower Rio Grande River, from the Mouth of the Pecos to the Gulf of Mexico*. Masters thesis, University of Texas at Austin, 1955.

## Estuarine Wetlands

Cattail/bullrush marshes occur primarily in the lower reaches of the Rio Grande, between 2 and 12 miles from the mouth in water up to 2 feet deep. They also grow in the floodplain immediately upstream from Anzalduas Dam. The last 2.5 miles of the river supports a community of cordgrass. *Spartina alterniflora* is the dominant species, growing in a narrow band 2 to 8 feet from the river (Ramirez 1986).

Black mangrove (*Avicennia germinans*) thickets are found in isolated patches, at the mouth of the Rio Grande. A small distributary channel funnels river water into a thicket immediately behind the fore dunes. These mangroves are the largest in the state, attaining a height of 12 feet. Of the estimated 7400 acres of mangroves in the state, 1200 acres occur in Cameron County. These thickets are very productive, providing shelter, nesting sites and food for wildlife (Espey Huston, 1981).

Mud flats near the mouth of the Rio Grande may support algal mat growth after extensive rains or storm tide inundation. Such algal mats contribute to the lagoon system by fixing nitrogen (Shew *et al* 1981).

At the edge of lagoons and tidal bodies, and extending into salt water a few inches deep, grows a community of succulent halophytes, known as Batis-Salicornia-Suaeda. It is composed chiefly of *Batis maritima*, *Salicornia perennis*, *S. Bigelovii*, *Suaeda conferta* and *S. linearis* in varying relative abundance. *S. tampicensis* and *Cakile lanceolata geniculata* have also been found in Cameron and Willacy counties (Johnston 1955).

The Laguna Atascosa National Wildlife Refuge is an important estuarine wildlife habitat. To its north, the outflow regions of the Cayo Atascoas, the North Floodway and the Arroyo Colorado provide additional nursery areas for marine life. This area represents a logical extension of the conditions that led to the formation of the Refuge, and the Lower Rio Grande Valley Development Council designated it as one of six unique ecological areas within the region. It is considered essential habitat for large waterfowl and for fish, shrimp and crabs. It is an important source of fresh-water and nutrients for the Laguna Madre (Corps of Engineers 1980).

## Palustrine Wetlands

Resacas are often dry during summer months, but have a varied flora when filled. Spikesedge and mud plantain are often surrounded by dock and flat sedges. A succession of plant communities grows in and around the swales and ponds. In saline areas, succulent halophytes give way to the borrichia community, followed by cordgrass and finally brush. In cultivated areas only

succulent halophytes are present. At lower salinity, ponds in agricultural areas may contain bull-rushes, cattails, smart weeds, water-lilies, arrowheads, spikerushes and water hyacinth, which occasionally congests a freshwater pond, preventing the growth of other species. Aquatic vegetation, such as arrowheads, widgeon grass and burheads is common in man-made tanks and stock ponds (Corps of Engineers 1980).

The Lower Rio Grande Valley is very distinctive in terrain, vegetation, and climate; thus, it has a number of unique ecological areas. The following is a description of these unique areas (as described in the USFWS Biological Report 88(36) November 1988) in Cameron County.

### Southmost Ranch

Southmost Ranch, located southeast of Brownsville, Texas, on the Rio Grande supports part of the remaining native Mexican palmetto community in the United States. Rio Grande thorn woodland also is present on the ranch. Southmost Ranch was ranked number 42 of the Top 100 Nationally Significant Fish and Wildlife Areas (USFWS, 1983). Within the 259-ha (640-acre) ranch, 6-ha (15 acres) are dominated by Mexican palmetto, 61-ha (150 acres) have mesquite and acacia with some palmetto, and the remainder is cultivated fields and pastures (USFWS, 1979). A variety of wildlife, including many peripheral species, exists in the Mexican palmetto forest community. Rare wildlife includes; the Mexican white-lipped frog (*Leptodactylus labialis*); Texas indigo snake; speckled racer; white-tipped dove (*Leptotila verreauxi*), tropical kingbird (*Tyrannus melancholicus*); white-collared seedeater (*Sporophila torqueola*); lesser yellow bat; and Mexican spiny pocket mouse (*Liomys irroratus*). The ocelot and jaguarundi may be present. Agricultural development and recreational use are primary threats to this area (USFWS, 1979).

### Laguna Atascosa National Wildlife Refuge

Laguna Atascosa National Wildlife Refuge (NWR), the southernmost waterfowl refuge in the Central Flyway, was established in 1946. It contains 19,680-ha (48,597 acres) and is the largest refuge in the Lower Rio Grande Valley. About 65,000 ducks winter on the refuge (USFWS, 1986). Laguna Atascosa NWR contains coastal prairies, salt flats, and low vegetated ridges supporting thick, thorny shrubs (Fleetwood, 1973). Habitat types of the refuge include: 9,720-ha (24,000 acres) of wetlands; 5,670-ha (14,000 acres) of coastal prairie; 3,280-ha (8,100 acres) of brushland; 405-ha (1,000 acres) of croplands; and 607-ha (1,500 acres) of grasslands and savannah (USFWS, 1986). The refuge fauna includes 354 bird and 31 mammal species. Ocelot and jaguarundi recently have been sighted in the vicinity of Laguna Atascosa (S. Labuda, personal communication). In a 1980-81 survey of the area, 8 species of amphibians and 23 species of reptiles were collected (Scott, 1982). Because of drought conditions during this

period, 95% of the American alligators (*Alligator mississippiensis*) in the Lower Rio Grande Valley were concentrated on the refuge (Scott, 1982).

#### Texas Sabal Palm Sanctuary

The National Audubon Society's Texas Sabal Palm Sanctuary, purchased in 1971, is south of Brownsville along the Rio Grande. The sanctuary preserves part of one of the largest remaining stands of the native Mexican Palmetto. In 1940, the palm grove was >40-ha (>100 acres). By 1971, only about 13-ha (32 acres) remained. Currently, the sanctuary has a total of 70-ha (172 acres), including 49-ha (120 acres) of old fields that are being revegetated, and an 8-ha (20 acre) resaca (Miller, 1985a). Many birds use the area (Land, 1983; Miller, 1985a); for example, plain chachalaca, common ground dove (*Columbina passerina*), golden-fronted woodpecker (*Centurus aurifrons*), common pauraque (*Nyctidromus albicollis*), green jay, great kiskadee, Altamira orioles, and reseat spoonbills (*Ajaia ajaja*). Nearly 400 plant species have been identified in the palm grove.

#### 7.3.4.5 Threatened and Endangered Species

The Lower Rio Grande Valley has a wide array of habitat types and a corresponding diversity of species including subtropical species, species of the southwestern desert, and prairie, coastal marshlands, eastern forest, and estuarine and marine environments. This significant diversity in habitat, coupled with the fact that the Lower Rio Grande Valley is the northernmost limit for several subtropical species, has resulted in a significant number of species that are recognized as threatened or endangered by the Federal and State governments. Table 7-6 identifies the threatened, endangered, and rare fauna and flora which are known to occur or are highly likely to occur in the study area.

#### 7.3.4.6 Archaeological/Cultural Resources

Lying at the extreme southern tip of Texas, Cameron County contains a rich and unique selection of cultural resource sites. Numerous prehistoric and historic sites are found within the county. As of 1985, 96 prehistoric sites had been officially recorded in the county. Since then this number has increased substantially. Additionally, the official number does not reflect nearly a hundred sites recorded in the 1930s by A. E. Anderson. At least one of the Cameron County prehistoric sites, the Garcia Pasture site, is listed on the National Register of Historic Places (NRHP). Dozens of historic sites have been recorded or reported from Cameron County. These sites include 13 listed on the NRHP. Historic sites include both standing structures such as the Charles Stillman House, the Southern Pacific Railroad Passenger Depot, and the Port Isabel Lighthouse,



Table 7-6  
Rare, Threatened, and Endangered Species of Potential Occurrence and Known  
Natural Communities in Cameron County

COMMON NAME	SCIENTIFIC NAME	STATUS			
		FWS 1	TPWD 2	TNHP 3	TOES 4
<b>AMPHIBIANS</b>					
Sheep-Frog	<i>Hypopachus variolosus</i>		T	G5S2	T
White-lipped Frog	<i>Leptodactylus fragilis</i>		E	G4S1	E
Mexican Treefrog	<i>Smilisca baudini</i>		T		T
Mexican Burrowing Toad	<i>Rhinophrynus dorsalis</i>		T	G5S2	T
Giant Toad	<i>Bufo marinus</i>				WL
Black-Spotted Newt	<i>Notophthalmus meridionalis</i>	C2	E	G1S1	E
Rio Grande Lesser Siren	<i>Siren intermedia Texana</i>	C2	E	G5T2S2	E
Rio Grande chirping frog	<i>Syrnophus cystignathoides</i>			G5S3	WL
<b>REPTILES</b>					
American Alligator	<i>Alligator mississippiensis</i>	T/SA			WL
Speckled Racer	<i>Drymobius margaritiferus</i>		E	G5S1	WL
Texas Horned Lizard	<i>Phrynosoma cornutum</i>	C2	T		T
Reticulate Collared Lizard	<i>Crotaphytus reticulatus</i>	C2	T	G3S2	T
Northern Cat-eyed Snake	<i>Leptoderia septentrionalis</i>		E	G5T5S2	T
Black-Striped Snake	<i>Coniophanes imperialis</i>		T	G3S2	WL
Texas Indigo Snake	<i>Drymarchon corais erebennus</i>		T		WL
Texas Scarlet Snake	<i>Cemophora coccinea linei</i>		T	G5T2S2	WL
Mexican Milk Snake	<i>Lampropeltis triangulum</i>				WL
Texas Tortoise	<i>Gopherus berlandieri</i>		T	G4S3	T
Green Sea Turtle	<i>Chelonia mydas</i>	T	T	G3S2	T
Hawksbill Sea Turtle	<i>Eretmochelys imbricata</i>	E	E	G3S1	E
Loggerhead Sea Turtle	<i>Caretta caretta</i>	T	E	G3S2	T
Kemp's Ridley Sea Turtle	<i>Lepidochelys kempi</i>	E	E	G1S1	E
Leatherback Sea Turtle	<i>Dermodochelys coriacea</i>	E	E	G3S1	E
<b>MAMMALS</b>					
Southern Yellow Bat	<i>Lesiurus ega</i>		T	G5S1	WL
Coues' Rice Rat	<i>Oryzomys couesi</i>		T	G5S2	T
Ocelot	<i>Felis pardalis</i>	E	E	G2S1	E
Jaguarundi	<i>Felis yagouaroundi</i>	E	E	G4S1	E
Cougar	<i>Felis concolor</i>			G4S2	
Jaguar	<i>Felis onca</i>	E	E	G3S4	E
Coati	<i>Nasua nasua</i>		E	G5S2	WL
Black Bear	<i>Ursus americanus</i>		E	G5S3	T
<b>BIRDS</b>					
Brown Pelican	<i>Pelecanus occidentalis</i>	E	E	G5S1	E
Reddish Egret	<i>Egretta rufescens</i>	C2	T	G4S2	T
Whitefaced Ibis	<i>Plegadis chihi</i>	C2	T	G4S2	T
Roseate Spoonbill	<i>Ajaia ajaja</i>			G5S4	
Wood Stork	<i>Mycteria americana</i>		T		T
Fulvous Whistling Duck	<i>Dendrocygna bicolor</i>				T
Least Grebe	<i>Tachybaptus dominicus</i>			G5S3	

CAMERON COUNTY REGIONAL PLANNING STUDY  
PRELIMINARY ENVIRONMENTAL ASSESSMENT

Masked Duck	<i>Oxyura dominica</i>			G5S4	WL
Osprey	<i>Pandion haliaetus</i>			G5S3	
American Swallow-tailed Kite	<i>Elanoides forficatus</i>		T	G5S2	T
Bald Eagle	<i>Haliaeetus leucocephalus</i>	E	E	G3S2	E
Common Black-hawk	<i>Buteogallus anthracinus</i>		T	G5S2	T
Northern Gray Hawk	<i>Buteo nitidus</i>		T	G5S1	T
White-tailed Hawk	<i>Buteo albicaudatus</i>		T	G5S2	T
Zone-tailed Hawk	<i>Buteo albonotatus</i>		T	G5S3	T
Golden Eagle	<i>Aquila chrysaetos</i>				WL
Merlin	<i>Falco columbarius</i>				T
Aplomado falcon	<i>Falco femoralis</i>	E	E	G4S1	E
American Peregrine Falcon	<i>Falco peregrinus anatum</i>	E	E	G3T2S1	E
Artic Peregrine Falcon	<i>Falco peregrinus tundrius</i>	T	T	G3T1S1	T
Piping Plover	<i>Charadrius melodu</i>	T	T	G2S2	T
Northern Jacana	<i>Jacana spinosa</i>			G5S3	T
Coastal Least Tern	<i>Sterna antillarum antillarum</i>				T
Interior Least Tern	<i>Sterna antillarum athalassos</i>	E	E	G4T2S2	E
Sooty Tern	<i>Sterna fuscata</i>		T	G5S2	WL
Black Skimmer	<i>Rhyncops niger</i>				T
Red-billed Pigeon	<i>Columba flavorostis</i>			G5S4	T
Ferruginous pygmy-owl	<i>Glaucidium brasilianum</i>		T		WL
Ringed Kingfisher	<i>Ceryle torquata</i>			G5S2	WL
Northern beardless-tyrannulet	<i>Camptostoma imberbe</i>		T	G5S3	WL
Rose -throated becard	<i>Pachyrhamphus aglaiae</i>		T	G4G5S2	WL
Brown Jay	<i>Psilorhynchus morio</i>			G5S2	WL
Black-capped Vireo	<i>Vireo atricapillus</i>	E	E		T
Tropical Parula	<i>Parula pitiayumi</i>		T	G5S3	T
Golden-cheeked Warbler	<i>Dendroica chrysoparia</i>	E	E	G2S2	E
Botter's sparrow	<i>Aimophila botteri</i>	C2	T	G4S3	T
<b>FISH</b>					
Blackfin Goby	<i>Gobionellus atripinnus</i>		E	G3S1	
Phantom shiner	<i>Notropis orca</i>		E	G2	E
River Goby	<i>Awaous tajasica</i>		T		WL
Opossum Pipe Fish	<i>Oostethus brachyurus</i>		T		
<b>PLANTS</b>					
Montezuma Bald Cypress	<i>Taxodium mucronatum</i>			G4S1	E
Runyon's Water Willow	<i>Justicia runyonii</i>	C2		G2S2	
Texas Palmetto	<i>Sabal mexicana</i>			G2S1	T
Adelia Vesyi	<i>Adelia vaseyi</i>			G2S2	
Texas Stonecrop	<i>Lenophyllum texanum</i>			G3S3	
Lila de los Llanos	<i>Anthericum chandleri</i>	C1		G2S2	
Plains Gumweed	<i>Grindelia oolepis</i>			G2S2	WL
Texas Azenia	<i>Azenia limitaris</i>			G2S1	
South Texas Ragweed	<i>Ambrosia cheiranthifolia</i>	C1		G1S1	
Gregg Wild Buckwheat	<i>Eriogonum greggii</i>			G2S1	
Runyon's Huaco	<i>Polianthes runyonii</i>	C2		G2S2	
Wherry Mimosa	<i>Mimosa wherryana</i>			G3S3	
Mission Fiddleweed	<i>Citharexylum spathulatum</i>			G2S2	

CAMERON COUNTY REGIONAL PLANNING STUDY  
PRELIMINARY ENVIRONMENTAL ASSESSMENT

Rio Grande Ballon Vine	<i>Cardiospermum dissectum</i>			G2S2
Johnston's Frankenia	<i>Frankenia johnstonii</i>	E	E	G2S2
Shurbleaf Bladderpod	<i>Lesquerella thamnophila</i>	C2		G1S1
Prostrate Milkweed	<i>Asclepias prostrata</i>	C2		G1S1
Terrey's Tetramerium	<i>Tetramerium platystegium</i>			G3S3
Ashy Dogweed	<i>Dyssodia tephroleuca</i>	E	E	
<b>NATURAL COMMUNITIES</b>				
Texas Palmetto Series				G2S1
Texas Ebony - Snake-eye Series				G2S2
Texas Ebony - Anacua Series				G2S1
Sugarberry-Elm Series				G4S4
Blackbrush Series				G5S5

1

U.S. Fish and Wildlife service (1989a) E- Endangered; T-Threatened; T/SA - Threatened due to similarity of appearance. Because of the similarity of appearance of the Texas American Alligator hides and parts to the hides and parts of other protected crocodilians, it is necessary to restrict commercial activities involving alligator specimens taken in Texas to ensure the conservation of other alligator populations, as well as other crocodilians that are threatened or endangered. USFWS, 12 October 1983. Fed. Reg. 48 (198):46332-46337. C1-Candidate, category 1. USFS has substantial information on biological vulnerability threats to support proposing to list as endangered or threatened. Data are being gathered on habitat needs and for critical designations. C2-Candidate, category 2. Information indicates that proposing to list as endangered or threatened is possibly appropriate substantial data on biological vulnerability and threats are not currently known to support the immediate preparation of rules. Further biological research field study will be necessary to ascertain the status and/or taxonomic validity of the taxa in Category 2. C3-Former candidate, rejected because more common, widespread, or adequately protected.

2

Texas Parks and Wildlife Department, Endangered/Threatened Species Data File (TPWD, 1988 a,b,c). E-Endangered; T-Threatened.

3

Texas Natural Heritage Program. Special Species and Natural Community Status. G1-Critically imperiled globally, extremely rare, 5 or fewer occurrences. G2-Imperiled globally, very rare, 6 to 20 occurrences. G3-Very rare and local throughout range or found locally in restricted range, 21 to 100 occurrences. G4-Apparently secure globally. G5-Demonstrably secure globally S1-5 state ranking of the same categories as those listed globally.

4

Texas Organization for Endangered Species; Endangered, Threatened and watch lists of Plants and Vertebrates of Texas (March, 1987 - plants and January, 1988 - vertebrates). E-State endangered species - any species which is in danger of extinction in Texas or in addition to its federal status. T-State threatened species - any species which is likely to become a state endangered species within the foreseeable future. WL-TOES Watch List - any species which at present has either low population or restricted range in Texas and is not declining or being restricted in its range but requires attention to insure that the species does not become endangered or threatened. (State or Federal)

structural groups associated with archaeological deposits such as Fort Brown and the Old Brunlay Plantation, and historic archaeological sites without structures such as the Palo Alto Battlefield and the Resaca de la Palma Battlefield.

Archaeological sites in the Cameron County area fall into four general chronological periods. The earliest period, the Paleoindian, dates to the very late Pleistocene and early Holocene. Cultures of this period are often associated with now-extinct genera of Pleistocene mammals, including larger species such as mammoth, mastodon, camel, and horse. The subsequent Archaic period represents a long and diverse occupation of the region, with potential shifts in subsistence, settlement, technology, and population dynamics. The final prehistoric stage, the Late Prehistoric, is marked by the introduction of pottery and the bow and arrow. In extreme South Texas, the Mexican influence is dramatic during this period. Most of the known prehistoric sites in Cameron County date to this period. The final period, the Historic, begins with the arrival of the Europeans. Aboriginal sites from this period are marked by the presence of historic artifacts. The earliest European settlement of the area dates to the Spanish period although little remains of that era. Settlement began in earnest after Mexico won its independence from Spain.

A long list of archaeological studies have been completed in the Cameron County area, beginning with the work of A. E. Anderson in the 1920s and 1930s. An engineer and amateur archaeologist, he recorded more than 400 sites in southern Texas and northeastern Mexico. E. B. Sayles used Anderson's data to define the Brownsville archaeological complex which represents the Late Prehistoric Mexican-influenced cultures of the area. Early professional studies were conducted in the general area by T. N. Campbell of the University of Texas as well as Richard MacNeish, then of the Peabody Museum at Yale. In more recent years, major studies have been conducted by T. R. Hester, E. R. Prewitt and R. J. Mallouf. The 1977 study by Mallouf, Baskin and Killen was a predictive model survey which still stands as some of the better work in the area. Recent geomorphic/geoarchaeological studies by Michael Collins have helped to clarify the stratigraphy of archaeological sites in the area.

The density of recorded cultural resource sites in the Cameron County is unusually high and the expected density of unrecorded sites is enormous. Because of the uniqueness of both the Mexican-influenced prehistoric cultural sites and the early historic sites, many either associated with the Mexican or early Texas occupation as well as the Mexican Water itself, an unusually high proportion of sites can be expected to be significant. Some of these sites will be eligible for the NRHP or worthy of formal designation as State Archaeological Landmarks. Any projects undertaken by political subdivisions of the state or with Federal funds or permitting should involve

archaeological studies as part of the planning process since location of significant sites may act as a constraint on timing or location of projects.

#### 7.3.4.7 Land-Use and Socioeconomic Conditions

A three step approach has been used in assessing social and economic conditions in Cameron County, as they pertain to this plan. A broad overview of county-wide land use is followed by analysis of the basic socioeconomic structure of Cameron. The analysis includes summaries of recent demographic, employment and industrial data. Lastly, a focus upon the colonias will underscore the need for the Regional Plan in Cameron County.

Cameron County land use revolves around agriculture. Slightly over 50% of the land is utilized for cropland (irrigated and dryland), pasture/hayland and orchard land. Rangeland comprises another 15% of the land use base. Coastal, riverine and drainage features influence a significant portion of the county. Over 17% of the county possesses surface water and another 3% is occupied by wetlands. Table 7-7 presents a breakdown of land use by soil conservation service classifications. [Of the less significant land uses, barren land occupies 8%, urban/built-up land 4% and recreation land 1% (SCS 1980)].

Of the 259,409 residents of Cameron County approximately 52% are female (July 1987). Ethnically, the population is largely hispanic. Seventy-nine percent (79%) of the people are of spanish decent and only .3% are black. The two major cities are Brownsville and Harlingen. Brownsville, the largest in the Lower Rio Grande Valley, supports a population of over 102,000. Harlingen, the third largest in the Lower Rio Grande Valley, has a population of nearly 55,000 people (1986 U. S. Dept. of Commerce, Bureau of the Census).

In 1989 Cameron County possessed a labor force of approximately 104,095 people. Unemployment for 1989 was nearly 12% (see Table 7-8 for labor and employment figures in the study area from 1985-1989). The largest sources of employment include trade, service and local government sectors (see Table 7-9 for employment by industry in the study area from 1985-1989).

Private industry produces 75% of all non-farm income in Cameron County. Services, retail trade and manufacturing make up the bulk of this 75%. The remaining 25% of non-farm income stems from government sources (see Table 7-10 for personal income by industry source in the study area from 1982 through 1987).

The target communities for water and wastewater improvements in Cameron County are the colonias. These colonias range in size from 15 to over 700 households which have an average of

4.81 occupants. Surveys conducted for Texas Department of Commerce grants indicate annual per capita income in the households surveyed ranges from a high of greater than \$14,300.00 to a low of less than \$3,000.00. A 1987 survey of the colonias in the Lower Rio Grande Valley by the Texas Department of Human Services indicates that 98.8% of the colonias population is Hispanic, with an average household income of \$6,932. This data coupled with the 47% unemployment rate reported in this study reveal the service economic depression in the colonias.

**Table 7-7  
 Land Use By SCS Classification**

Land Use Category	Cameron Acreage	% of Total
Urban and Built up Land		
Urban	28638.31	3.86%
Other	30.66	0.00%
Agricultural Land	79337.94	10.70%
Cropland	292837.52	39.48%
Cropland (Irrigated)	5549.82	0.75%
Pasture and Hay Land	3020.20	0.41%
Pasture and Hay Land (Irrigated)	10149.12	1.37%
TOTAL AGRICULTURE	390,894.66	52.71%
Rangeland		
Open	78617.39	10.60%
Bushy	19163.75	2.58%
Water	128,182.52	17.28%
Wetlands	23655.74	3.19%
Barren Land	51726.80	6.97%
	11237.62	1.51%
Recreation Land	7573.51	1.02%
Other Land	2039.02	0.27%
<b>TOTAL</b>	<b>741759.92</b>	

Source: Soil Conservation Service 1980

In 1989 Cameron County possessed a labor force of approximately 104,095 people. Unemployment for 1989 was nearly 12% (see Table 7-8 for labor and employment figures in the study area from 1985-1989). The largest sources of employment include trade, service and local government sectors (see Table 7-9 for employment by industry in the study area from 1985-1989).

**Table 7-8**  
**Labor Force, Total Employment and**  
**Unemployment of the Study Area**  
**\*1985-1989**

	<b>Cameron County</b>	<b>% Change</b>
<b>Labor</b>		
1985	92,468	
1986	94,727	2.44%
1987	95,788	1.12%
1988	98,828	3.17%
1989	104,095	5.33%
<b>Total Employment</b>		
1985	79,092	
1986	79,759	0.84%
1987	82,050	2.87%
1988	85,725	4.48%
1989	91,866	7.16%
<b>Unemployment Rate</b>		
1985	14.5	
1986	15.8	+8.96%
1987	14.3	-9.49%
1988	13.3	-6.99%
1989	11.7	-12.03%

Source: Texas Employment Commission 1989

**Table 7-9**  
**Employment by Industry**  
**In Cameron County**  
**1985 - 1989**

<b>Sector</b>	<b>1985</b>	<b>1986</b>	<b>1987</b>	<b>1988</b>	<b>1989</b>
Agriculture	1806	1740	1757	1929	1974
Mining	81	76	44	42	14
Construction	3193	3037	9588	9610	2035
Manufacturing	9694	9209	9588	9610	10419
Transportation	3424	3236	2926	2950	2918
Communications and Utilities					
Trade	18276	17992	17466	17716	19213
Finance, Insurance, and Real Estate	3438	3350	3422	3501	3550
Service and other	11362	11787	12372	13711	16260
State Government	1875	2011	1939	2051	2014
Local Government	11254	12136	12891	13266	13975
<b>TOTAL</b>	<b>64403</b>	<b>64574</b>	<b>64735</b>	<b>66833</b>	<b>72372</b>

Source: Texas Employment Commission 1989

Private industry produces 75% of all non-farm income in Cameron County. Services, retail trade and manufacturing make up the bulk of this 75%. The remaining 25% of non-farm income stems from government sources (see Table 7-10 for personal income by industry source in the study area from 1982 through 1987).

The target communities for water and wastewater improvements in Cameron County are the colonias. These colonias range in size from 15 to over 700 households which have an average of 4.81 occupants. Surveys conducted for Texas Department of Commerce grants indicate annual per capita income in the households surveyed ranges from a high of greater than \$14,300.00 to a low of less than \$3,000.00. A 1987 survey of the colonias in the Lower Rio Grande Valley by the Texas Department of Human Services indicates that 98.8% of the colonias population is Hispanic, with an average household income of \$6,932. This data coupled with the 47% unemployment rate reported in this study reveal the service economic depression in the colonias.

### 7.3 Alternatives Analysis

The TWDB's Environmental Assessment guidelines require evaluation of alternative engineering methods and siting of facilities and subsequent evaluation of these alternatives with respect to environmental constraints. A preliminary set of alternatives was evaluated during this study. Sites and treatment methods with the most significant environmental constraints were avoided (for example, wetlands and wildlife management areas for sites; and on-site disposal in areas of poor soil conditions for treatment methods) to the highest degree possible. A detailed alternative analysis will be conducted in more specific documents (i.e. site specific Environmental Assessment or Environmental Information Documents) as necessary for specific state and federal programs.

### 7.4 Potential Environmental Impacts

Environmental constraints, if not avoided, can often become environmental impacts. During the preliminary design phase of this study environmental constraints were identified and avoided to the greatest extent possible. Potential impacts that could occur in Cameron County, if proper design does not occur, include, among others, impacts to threatened and endangered species, wetlands and cultural resources. At this preliminary level of evaluation none of the proposed water and wastewater plans were noted to have any significant environmental impacts. Again, a more detailed Environmental Assessment for any specific site will be necessary to further evaluate potential environmental impacts.



**Table 7-10**  
**Personal Income by Industry Source**  
**in the Study Area (thousands of dollars)**  
**1982-1987**

	1982	1987
<b>Nonfarm</b>	<b>1,043,681</b>	<b>1,233,031</b>
<b>Private</b>	<b>851,567</b>	<b>925,601</b>
Manufacturing	171,604	158,976
Mining	12,276	3,774
Construction	85,651	70,882
Wholesale/Trade	75,805	55,975
Retail Trade	165,561	170,338
Finance, Insurance and Real Estate	51,646	68,183
Transportation, Communication, and Utilities	75,995	79,485
Services	194,006	281,067
Ag. Services, Forestry Fisheries and other	19,023	36,921
<b>Government</b>	<b>192,114</b>	<b>307,430</b>
Federal Civilian	27,169	33,939
Federal Military	6,600	6,962
State and Local	158,345	266,529
<b>Total</b>	<b>2,087,362</b>	<b>2,466,062</b>

Source: U. S. Department of Commerce 1987

## **8.0 INSTITUTIONAL AND LEGAL ISSUES**

### **8.1 Regulatory Overview**

Federal, State and local regulations will affect the development of water supply treatment and distribution facilities, and wastewater treatment and collection facilities within Cameron County. This section reviews Federal regulations, including U.S. Fish and Wildlife Service (FWS) Section 7 consultation for threatened and endangered species; U. S. Army Corps of Engineers (USCE) 404 permits for stream crossing and/or dredge and fill operations; the Environmental Protection Agency (EPA) - National Pollutant Discharge Elimination Systems (NPDES) permit for wastewater discharges; and the National Historic Preservation Act for cultural resources. State environmental regulations expected to be of concern include the Texas Antiquities Code, which applies to all action taken by political subdivisions of the State of Texas, and the Texas Water Commission (TWC) Water Quality Permit for wastewater discharges and appropriation of surface water rights. Local environmental regulations expected to be of particular concern include Cameron County's septic tank and local permitting, etc. Table 8-1 provides a synopsis of environmental considerations which may be of concern in the development of water supply facilities.

### **8.2 Federal Regulatory Considerations**

#### **Clean Water Act**

The Clean Water Act (CWA) prohibits the discharge of pollutants from any discernible point source into the waters of the U.S., with the exceptions of those discharges that are permitted in compliance with the CWA. Permits authorized under the CWA that may be of concern in this plan include Section 404 permits for dredge and fill as issued by the USCE and the NPDES for the discharge of water as issued by the EPA.

#### **USCE Section 404 Permit**

Section 404 of the CWA, as administered by the USCE, regulates the placement of dredged (excavated) or fill material in "Waters of the U.S." Waters of the U.S. are broadly defined in Section 404 as any body of surface water (such as oceans, bays, rivers), all surface tributary streams with a defined channel (including intermittent waterways), any in-stream impoundments (i.e., lakes and ponds), many off-channel impoundments, and wetlands. "Dredged or fill material" has also been given rather broad meaning to include almost any material or object used for construction such as dirt, rocks, concrete, piles, pipes, etc. In regards to construction of a water intake structure or pipeline where a crossing or direct involvement with a surface tributary stream, impoundment, or wetland may be required, placement of the pipeline itself (regardless of construction material) and

**Table 8-1  
Synopsis of Environmental Regulatory Programs**

Program	Considerations
<p><b><u>Federal</u></b></p> <p><b>Section 7 of the Endangered Species Act of 1973, as amended</b></p>	<ol style="list-style-type: none"> <li>1) Formal Section 7 consultation with FWS and USCE and the applicant may be of USCE permit or any other Federal Permit.</li> <li>2) It will be the responsibility of the applicant to prove whether or not Federally-listed species occur in the project.</li> <li>3) If formal Section 7 consultation is required, schedule delays up to 90 days can be expected.</li> </ol>
<p><b>Corps of Engineers 404 Permit Requirement</b></p>	<ol style="list-style-type: none"> <li>1) A permit is required for pipeline crossing of surface water tributaries and waterways</li> <li>2) A "general permit" exists which significantly reduces the time and paperwork for pipeline construction authorizations.</li> <li>3) Should have information on potential impacts to cultural resources and threatened or endangered species prior to involvement of Corps.</li> </ol>
<p><b>EPA - NPDES Discharge Permit</b></p>	<ol style="list-style-type: none"> <li>1) Establishes criteria for treatment and discharge of wastewater, including pollutant limitations, prohibitions, and monitoring and reporting criteria.</li> <li>2) Administered by Texas Historic Commission and State Historic Preservation Officer.</li> <li>3) Generally requires archaeological survey of affected areas, and, occasionally, testing of more important sites; in some cases, indirect impact areas must be considered.</li> <li>4) Sites which are determined to be eligible for the National Register of historic Places may need preservation and/or mitigation.</li> </ol>

**Table 8-1  
Synopsis of Environmental Regulatory Programs  
(continued)**

<b>Program</b>	<b>Considerations</b>
<b><u>State</u></b>	
Texas Antiquities Code	<ol style="list-style-type: none"><li>1) Applies to actions taken by political subdivisions of the State of Texas.</li><li>2) Administered by Texas Antiquities Committee.</li><li>3) Generally requires archaeological survey of area of primary impact, and, occasionally, testing of potentially important sites.</li></ol>
TWC - State Water Quality Permit	<ol style="list-style-type: none"><li>1) Parallel program to NPDES permit.</li><li>2) Designed to maintain ambient stream standards.</li><li>3) Administered by Texas Water Commission.</li></ol>
TWC - State Water Rights Permit	<ol style="list-style-type: none"><li>1) Texas Water Law requires that a permit be acquired to divert, use or store State waters.</li><li>2) Typical components of water rights application include a water conservation plan, an Environmental Assessment (or, possibly, an Environmental Impact Statement) and detailed engineering information.</li></ol>

any trench backfill material within the area or jurisdiction is subject to permit requirements under 404 regulations.

The USCE Galveston District, has 404 regulatory responsibility for Cameron County, maintains a "general permit" for most pipeline construction projects. A general permit is a pre-authorized permit for a specifically identified activity which is conducted under certain specified conditions. General permits are issued on either a nationwide or regional basis. The purpose of general permits is to provide paperwork and time expenditure relief for permitting actions which are determined to be routine and resulting in little or no impacts to waters of the U.S.

With regard to water and wastewater storage and transmission facilities, crossing of surface tributaries with water lines will be necessary and, therefore, legally subject to permitting requirements under federal law. As pipeline construction activities are considered minor works with minimal impacts to waters of the U.S. by the USCE Galveston District (hence the general permit), the USCE does not spend much effort trying to enforce and specifically permit all pipeline construction projects. Even though the legal requirement for permitting exists, the USCE generally takes the position that as long as pipelines are constructed according to the conditions of the general permit (basically, return of natural contours and no permanent obstruction of water-courses); that no impacts occur to cultural resources or threatened or endangered species for which other federal regulations exist; and that no one (agency or individual) objects and complains about the activity, the activity is authorized under the general permit without formal notification and paperwork.

Under 404 regulations a general permit may be suspended for any given project and a full individual permit required if impacts to cultural resources, threatened or endangered species, or other factors of the public health and welfare are potentially to occur. An individual permit action can require from a minimum of three months to a year or longer to complete, and may also require public hearings and an Environmental Impact Statement. It should be noted that any of the service options which do or have a high probability of resulting in significant impacts to cultural resources or federally listed threatened or endangered species stand a high probability of not being authorized under a general permit.

### EPA-NPDES Permit

All point source discharges of wastewater into the waters of the U.S. are regulated under the CWA and require a NPDES permit. The NPDES permit establishes the criteria for treatment and discharge of the wastewater including pollutant limitations, prohibitions, and monitoring and reporting criteria. The treatment and discharge conditions described in the NPDES permit (in conjunction with the TWC - State Water Quality Permit) are typically designed to maintain ambient stream standards (as defined by the TWC) and require wasteload evaluation of all the cumulative impacts of all point sources discharged into receiving streams. Detailed evaluation of stream standards and existing wasteloads is required to determine the conditions of the NPDES permit.

### USFWS Section 7 Consultation for Threatened and Endangered Species

It is possible that formal Section 7 consultation between the FWS, USCE, and the County will be required before issuance of a USCE permit because of perceived direct and indirect impacts to Federally-listed Threatened and Endangered Species. Additionally, environmental groups may petition the FWS and the USCE to initiate Section 7 consultation if it is not initiated by the applicant (local project sponsor). It is the responsibility of the applicant to prove whether or not Federally-listed threatened or endangered species occur on the project area. If Section 7 consultation is required, considerable schedule delays (60-90 days minimum) will be inevitable during the period in which FWS conducts biological assessments and forms its "biological opinions".

### National Historic Preservation Act

Protection of cultural resource sites may be invoked through application for a Section 404 or Section 10 permit from the USCE should structures or lines be located in waters of the United States. Should the USCE become involved, it may request the opinion of the State Historic Preservation Officer (SHPO) concerning the effect of the project on cultural resources. Because of the high potential for cultural resources in the general area, it is certainly possible that the SHPO would, like the Texas Antiquities Committee (TAC), require an archaeological survey, site evaluation, and protection and/or mitigation measures for important sites located during the initial survey. In such cases, where both the TAC and the SHPO have jurisdiction, one agency will operate as the lead agency.

Cultural resources studies may be coordinated through the TWDB, where TWDB funds are utilized, or coordinated directly through the TAC.

### 8.3 State Regulatory Considerations

#### Texas Antiquities Code

Cameron County and all municipalities, water districts, etc. in the county are considered to be political subdivisions of the state under the provisions of the Texas Antiquities Code, and, therefore, must consider the effects of its actions upon possible archaeological sites. Under the code, all archaeological sites, either historic or prehistoric, and significant historic structures on lands belonging to or controlled by political subdivisions of the state are automatically considered to be State Archaeological Landmarks (SALs) and may be eligible for protection. Construction projects by the district will require a Texas Antiquities Permit and coordination with the TAC. In practice, this often necessitates an archaeological and historical survey or previously unsurveyed areas prior to any potentially destructive action. Sites recorded during this survey must be evaluated; those which are of significant historical or scientific value will be formally designated for SAL status and measures of protection or mitigation of adverse impact negotiated between the political subdivision and the TAC.

#### TWC-State Water Quality Permit

The TWC-State Water Quality Permit is the State of Texas' EPA-NPDES parallel program for wastewater discharges. Like the NPDES permit, the State Permit is designed to maintain stream standards. The permit is administered by the Wastewater Permits Section of the TWC. Any new discharges or change in quantity and/or quality of discharge will likely require both a NPDES and State Water Quality Discharge Permit.

#### TWC-State Water Rights Permit

The development of this plan requires a thorough analysis of the water demand and supply and use of existing water. Expected water supply shortage may require one or more of the following actions related to water rights: 1) reallocation of existing agricultural rights and/or 2) development of a surface water supply source and, thus, the need for a water (storage, diversions, and/or use) rights permit as issued by the TWC.

Anyone who desires to appropriate water must make an application in writing to the Texas Water Commission. The TWC, as a regulatory agency with broad discretionary powers, is charged with the administration of rights to the surface water resources of the State. The TWC consists of three members appointed by the Governor for six-year terms, with the consent of the Senate. The Chairman is designated by the Governor.

The Rules, Regulations, and Modes of Procedure of the Texas Water Commission prescribed the procedures for applying for a water permit. The TWC will consider an application for approval if the application is in proper form, complies with statutory provisions, contemplates and authorized use of water, does not impair existing water rights or vested riparian rights, and is not detrimental to the public welfare and environment.

After approval of an application, the TWC issues a permit giving the applicant the right to take and use water only to the extend stated. Permits may be "regular," "seasonal," "temporary," or "contract" in nature. A "regular" permit is permanent in nature and does not limit the appropriator to the taking of water during a particular season or between certain dates. A "seasonal" permit is also permanent in nature, but the taking of water is limited to certain months or days during the year. A "temporary" permit is granted for a period of time not exceeding three years and does not vest in the holder any permanent right to the use of water. A "contract" permit is granted for a stated duration and governs the use of water to be obtained from the storage facilities owned by another person or entity. A "contract" permit requires a written consent agreement or "contract" with the owner of the facility.

The TWC may also grant permits for the impoundment and storage of water with the use of the impounded water to be determined at a later date by the TWC.

Once the right to the use of water has been perfected by (1) issuance of a permit from the TWC and (2) subsequent beneficial use of the water by the permittee, the water authorized to be appropriated under the terms of the particular permit is not subject to further appropriation until the permit is cancelled. Formal cancellation of unused permits and certified filings is possible by administrative action initiated by the TWC or by judicial proceedings to adjudicate water rights between claimants (TWDB, 1977).



## **9.0 REVIEW OF FINANCING PROGRAMS**

### **9.1. Bond Market**

Construction of public works projects, like those described in Sections 4.0 and 5.0 of this report, is frequently financed by the selling of bonds. Entities such as cities, river authorities and other political subdivision can issue bonds and use the proceeds to construct capital improvement projects. The bonds are repaid, with interest, from taxes and/or fees collected in the service area. Because bonds issued by public entities are for the purpose of providing services, they are classified under federal law as "tax exempt," and the interest paid to bond holders does not have to be declared as ordinary income. Consequently, these bond holders are willing to lend their financial resources to public entities at a lower rate of interest than the going market rate.

#### **9.1.1 Texas Water Development Fund and Water Assistance Fund**

In 1985 constitutional amendments were approved by Texas voters, authorizing the issuance of \$980 million of general obligation bonds to fund water development projects. An additional \$250 million was approved to establish the Water Bond Insurance Program which guarantees bonds issued by local governments. This was in addition to \$600 million previously authorized for the Water Development Fund and \$40 million appropriated for the Water Assistance Fund, which includes the Water Loan Assistance Fund. These loan funds are administered by the Texas Water Development Board (TWDB).

The Water Development Fund is used to provide loans to political subdivisions for the construction of water supply, wastewater treatment, flood control, regional water and wastewater facilities, and other related projects. Historically, the Water Development Fund was reserved for use by "hardship" political entities, who were unable to sell bonds at reasonable rates on the open market. The passage in 1985 of House Bill 2 resulted in an expansion of this program to include the use of the funds to provide loans for the construction of regional facilities. The TWDB is also authorized to purchase an interest in local/regional water supply or wastewater treatment projects in order to provide future excess capacity. The acquisition and/or construction of any one of the following engineering projects may be eligible for consideration under the Water Loan Assistance Program, Water Development Program, Water, Wastewater and Storage Facilities Acquisition Program, Water Quality Enhancement Program or Flood Control Program, as appropriate:

- conservation and development of surface or subsurface water resources, including the acquisition, modification or construction of dams, reservoirs and underground storage, or the the acquisition or purchase of rights in underground water and the drilling of wells;
- development of saline or brackish water, including desalination facilities;

- transportation facilities used to transport water to treatment facilities, storage or wholesale purchasers (retail distribution systems are not included);
- water treatment, including filtration and water and wastewater treatment plants;
- treatment works including those used in the storage, treatment, recycling and reclamation of waste, or which are necessary to recycle or reuse water at the most economical cost;
- structural and nonstructural flood control and drainage facilities.

Cities, special purpose districts, nonprofit water supply corporations and regional entities can apply to the TWDB for loan funds. In accordance with House Bill 2, the Board will continue to encourage local political entities to implement regional water supply and wastewater treatment facilities, consistent with the Texas Water Plan and the State Water Quality Management Plan. The bonds are issued as State of Texas General Obligation Bonds and, because they are guaranteed by the state, provide funding at generally a lower rate of interest than bonds sold on the open market. The interest rate is intended to reflect the true interest cost to the state, including issuance costs. The bonds are retired by the TWDB from funds collected from each loan.

Priority for the funds is given to regional projects which, by definition, serve more than one city, district, or other political entity. Individual cities and special purpose districts must be classified as "hardship cases" in order to be eligible. Small cities that do not have a credit rating and would have difficulty obtaining loans are typical applicants. Even though these cities would have difficulty obtaining funds on the open market, they must also be able to demonstrate to the TWDB that the funds will be repaid.

#### Water, Wastewater and Storage Facilities Acquisition Program

As a result of comprehensive water legislation in 1985, the TWDB was authorized to issue up to \$400 million in State of Texas General Obligation Bonds in order to purchase an undivided interest in water, sewer and flood protection projects insuring that optimum project development can be achieved. The TWDB's share could be as high as 50 percent. However, because of the State's poor financial condition there has not been a source of revenue available to the TWDB to repay debt service on this obligation. As a result, implementation of the program has been slow.

The program allows for projects to be designed to meet the future needs of a community, even if current demand is insufficient to provide the necessary revenues to retire the debt load associated with a larger project. Through the State Participation Program, a local entity could plan a larger project than necessary, with phasing of elements to the maximum extent possible, and solicit financial assistance from the TWDB. The TWDB would pay up to 50 percent of the project

costs and hold its share until some future date, at which time the local entity would be required to buy the Board's share. The local entity must enter into a binding agreement obligating it to begin paying debt service on the Board's original share, plus interest and financing costs, within a period of 8-12 years following project completion.

#### 9.1.2 State Revolving Loan Fund

##### 9.1.2.1 Overview

The Texas State Water Pollution Control Revolving Fund (SRF) is administered by the TWDB and provides a source of low interest loan money for the construction of wastewater treatment facilities. The 1987 Clean Water Acts Amendments replaces the federal construction grants program and provides federal funds, at zero interest, which must be match by the state. State funds are provided from the sale of Texas Water Quality Enhancement bonds. By providing up to one dollar of state funds for each dollar of federal funds, the TWDB has been able to increase the availability of the funds, while making the loan money available at an interest rate of 5 to 6 percent.

Successful applicants must issue bonds, which are purchased by the TWDB. The applicant then redeems the bonds with revenues from taxes or user fees. As the loans are repaid and the bonds retired, the federal funds can be used again for subsequent loans with new bond money. In this manner, the federal government has provided a perpetual fund to sustain an ongoing program for water quality improvements.

##### 9.1.2.2 Eligibility

Any public entity having the authority to treat sewage and is designated as (or has applied for designation as) a waste treatment management agency is eligible to apply for these funds. This includes cities, towns, special purpose districts, river authorities or other public bodies. Eligible projects include:

- construction of secondary and advanced treatment works;
- alternatives to secondary and advanced treatment works;
- construction of interceptor sewers;
- repairs to existing collection systems to reduce inflow/infiltration;
- construction of reserve capacity;
- rehabilitation or replacement of collection systems necessary to overall project integrity; and
- new collection systems to complement existing or planned treatment capacity.

### 9.1.2.3 Conditions for a SRF Loan

The following conditions must be met in order to be eligible for a SRF loan:

- have the project on the TWDB's priority project list;
- develop or have in effect a water conservation plan;
- have an eligible project;
- demonstrate that a dedicated source of funds exists for loan repayment;
- use best practice treatment technology;
- have a cost effective project;
- consider alternative waste management techniques and innovative alternative waste treatment processes;
- show that I/I is not excessive or include I/I reduction as a part of the project;
- consider the project's recreational and open space potential;
- be consistent with area wide 208 and 303e water quality management plans;
- implement a user fee system and demonstrate financial and managerial capability;
- for projects over \$10 million, apply "Value Engineering;"
- obtain an environmental determination in compliance with the National Environmental Policy Act;
- comply with the Davis-Bacon Act in setting wage rates for labor used during construction; and
- consider the development of a capital financing plan.

### 9.1.2.4 Applying for a SRF Loan

It is advisable for an entity seeking to apply for a SRF loan to schedule a preplanning meeting with the TWDB staff. A representative of the entity's governing body and its engineering consultant should be present in order to obtain information about the eligibility of the project and the preparation of the application. When the facilities plans and environmental documents have been filed, a preapplication meeting with the TWDB staff should be scheduled.

The TWDB's annual schedule for processing an application is as follows:

- On or before April 1: A priority rating report is solicited by the TWDB Executive Administrator from all entities wishing to be included in the forthcoming year's intended use plan. The following information is required:
  - description and condition of existing facilities;

- description of present wastewater problems and future needs;
  - analysis of the planning area to include current and projected population, wastewater sources, influent and effluent characteristics and uses of receiving bodies of water;
  - status of the required wastewater permit for the project;
  - description of the means proposed to correct present problems and meet future demand;
  - estimated total cost; and
  - estimated project schedule.
- On or before July 1: The priority report is due at TWDB. Late applications will be added and considered with the appropriate population class list, in order of the date of submission, if all of the funds are not allocated.
  - By July 1: Project rating reports filed by applicants are used by TWDB staff to prepare a preliminary intended use plan.
  - After July 1: A public hearing is held on the intended use plan. By this date, the applicant must have filed a certified copy of a resolution of its governing body estimating total project costs and committing to file an application for an SRF loan on or before March 15 of the following year. Failure to do this will mean that the project will not be included in the intended use plan.
  - September: The intended use plan is presented to the Board for approval at a regularly scheduled meeting after federal appropriations have been made and funding levels established.
  - October: Board sets funding limits and determines which projects will be funded in each category. If projects cost less than estimated, remaining funds become available to those lower on the list. Those costing more can obtain additional funds from the water quality enhancement fund at higher interest rates.
  - March 15: Loan applications are due. This consists of an SRF engineering plan, environmental documents, water conservation plan and general, legal and fiscal data. Upon approval of the loan, contract documents are prepared and submitted to TWDB for review and approval. Following approval, the applicant then hires engineering contractors, using an open bidding system. The applicant should print the bonds and await notification of a closing date from TWDB staff. Upon closure of the loan, the cost for preparation of the required reports and contract documents used in the application can be reimbursed from the loan proceeds.

Because the rules specify that a new Intended Use Plan and priority funding list must be developed each year, an unsuccessful applicant must begin the process anew to secure funding in the following year.

### 9.1.3 State Participation Program

#### 9.1.3.1 Program Description

The Community Development Block Grant (CDBG) program was created by United States Congress in 1974 and is administered by the U.S. Department of Housing and Urban Development (HUD). Cities exceeding 50,000 population and counties larger than 200,000 are funded through the entitlement program; smaller entities are included in the non-entitlement category. Since 1981 the responsibility for administering the non-entitlement portion of the CDBG program has been transferred to the Texas to the Department of Commerce's Finance Division.

#### 9.1.3.2 Programs

The Community Development Fund contains about two-thirds of the total funding. Public works projects funded under the program include water/sewer improvement, street/drainage improvements, community centers and handicapped accessibility projects.

Texas Capital Fund is part of a program designed for the express purpose of creating new permanent jobs, primarily for low or moderate income persons. It is part of the Texas Community Development Program and encourages business development and expansion.

The Emergency/Urgent Need fund was established to respond to natural disasters and urgent situations that pose a threat to public health and safety. To qualify under the first category, the Governor must declare a state of emergency. The second category would be more applicable to water and sewer projects. The urgent need must have arisen within the last 18 months and must be based on satisfactory documentation completed or certified by the Texas Department of Health's Regional Director of Environmental and Consumer Health Protection.

The Special Impact Fund, funded under the Texas Community Development Program, provides funding to assist in infrastructure development in severely distressed unincorporated areas of counties. Water, sewer, street and drainage are the only eligible projects, which have to compete for funding in an annual statewide competition.

The Planning/Capacity Building Fund is designed to help communities to become more involved in community and economic development projects. It is also awarded as a result of a statewide

competition and focuses on planning activities that may be addressed with Texas Community Development Program funds and other similar resources.

## 9.2 Economically Distressed Areas Program (EDAP)

The Economically Distressed Areas Program (EDAP) is a recent financial assistance program designed to provide financial assistance for water and wastewater facilities in economically distressed areas. An economically distressed area is defined by the TWDB as an area in which water supply or sewer services are inadequate to meet minimal needs of residential users and in which financial resources are inadequate to meet these needs.

The general goal of the EDAP is to encourage and provide grant assistance to political subdivisions to serve economically distressed areas and further the orderly development of regional water and wastewater facilities. To ensure this goal, EDAP monies may be used to fund for the entire range of activities related to the development of such facilities, including preliminary planning to determine the feasibility of a project:

- engineering, architectural, environmental, legal, title, fiscal, or economic studies;
- surveys, designs, plans, working drawings, specifications, procedures;
- any condemnation or other legal proceedings; and
- erection, building, acquisition, alteration, remodeling, improvement, or extension of a project, or the inspection or supervision of any of the foregoing items.

### 9.2.1 Applicability and Eligibility

Counties eligible for this program must either meet income (average per capita income of 25% below state average) and unemployment rate (average rate of 25% above state average) or be adjacent to an international border. Cameron County has been identified as an affected county by the TWDB.

### 9.2.2 Funding Mechanisms, Requirements and Repayment

The amount and form of financial assistance and repayment is typically based upon need and customer ability to pay. Need is first and foremost determined by the presence of serious and unacceptable health hazard to residents. Repayment is typically a function of ability to pay and other available source of funding available to the subdivision. The TWDB has developed a model that calculates the ability to pay based on the rates, fees, and charges that the average customer to be served by the project will be able to pay based on a comparison of what other families of similar income pay for comparable services. In short, the amount and form of financial assistance

and repayment is unique for each political subdivision and facility engineering data must be evaluated by the TWDB to determine the terms associated with the financial assistance.

### Facility Engineering

Facility engineering is made up of the two phases of studies and tasks that are performed to determining the engineering feasibility of water and wastewater facilities and to obtain plans and specification for constructing the facilities for an economically distressed area. The two phase of facility engineering are described below:

Facility Engineering Phase I - The studies, tasks, and reports that are performed to determine the most cost-effective alternative to meet water and wastewater facilities needs, determine the feasibility of the proposed alternative, and prepare an application for board financial assistance to construct the alternative. The requirements of Phase I are shown in Table 9-1.

Facility Engineering Phase II - The tasks that yield design reports, construction drawings, technical specifications, instructions, and other contract conditions and forms needed to construct water or wastewater facility.

The TWDB may through funds available through the research and planning fund, provide up to 75% of the cost of facility engineering.



## 10.0 RECOMMENDATIONS

### 10.1 Recommendations for Water Supply Options - Cameron County.

- Pursue the implementation of the Rio Grande Valley Water Conservation Project.
- Implement area-wide water conservation programs.
- Initiate area/regional treated wastewater reuse/recycling programs.
- Investigate programs to eliminate/decrease irrigation water losses with water savings being used to meet future municipal , industrial and domestic water demands.
- Continue to research the use of using low cost RO membrane technology to treat ground water supplies.
- Secure (purchase) irrigation water rights to convert to municipal rights as opportunities prevail.
- Continue prudent development of the Lower Rio Grande Valley aquifer for direct use or blending with existing supply.

### 10.2 Recommendations for Water Supply Options - Colonias.

- The PUB should provide water service to Hacienda Gardens (No. 7B), including a centralized water distribution system. The estimated cost for these improvements is \$330,000.
- The PUB should provide water service to the portion of Cameron Park currently served by the Military Highway WSC. The estimated cost of these improvements is \$2,970,000.
- A centralized water distribution system, should be constructed in the following colonias, with treated water supply being furnished by Santa Rosa (Cameron County WCID):
  - 6W -T2 Unknown Subdivision,
  - 13W -Q Unknown Subdivision (Santa Rosa),
  - 14W - W,
  - 15W- R Unknown Subdivision (S. Santa Rosa),
  - 16W-X Unknown Subdivision (Santa Rosa),
  - 17W- S.
- All raw and treated water purveyors who are currently serving colonias should continued to do so in the future, except for the Military Highway WSC's service to part of Cameron Park.

### 10.3 Recommendations for Wastewater Options - Colonias.(Table 10-1)

### 10.4 Implementation Schedule

- The PUB of Brownsville should immediately prepare an application to the TWDB for Phase I Engineering funds for Cameron Park under the Economically Distressed Areas Program (EDAP). Cameron Park is on the TWDB list of identified priority colonias.
- The PUB of Brownsville should begin screening the remainder of colonias within the PUB service area and begin preparation of EDAP funding application(s) for other areas of significant need.

TABLE 10-1  
Wastewater Collection, Treatment And Disposal Options  
for The Colonias of Cameron County, Texas

CAMERON COUNTY REGIONAL PLANNING STUDY  
RECOMMENDATIONS AND IMPLEMENTATION SCHEDULE

Desig.	Colonia		Year 2020			Sewered (Y/N)	Recommended Treatment Method	Recommended Disposal Method	Total Cost
	Name	Pop.	Unit Density (1/Ac)	WW Gen. (MGD)					
1B	Cameron Park	7,327	4.15	0.73	Y	Wastewater Treatment Plant	Robindale Sewage Treatment Plant	\$3,413,000	
2B	Olmito	3,532	1.86	0.35	Y	Wastewater Treatment Plant	Robindale Sewage Treatment Plant	\$3,605,000	
3B	Stuart Subdivision	1,960	8.02	0.20	Y	Wastewater Treatment Plant	Robindale Sewage Treatment Plant	\$2,005,000	
4B	San Pedro Carmen	1,450	4.07	0.15	Y	Group Together	To Robindale Sewage Treatment Plant	\$2,700,000	
8B	Villa Nueva	798	2.55	0.08	Y				
11B	Villa Cavazos	399	2.31	0.04	Y				
5B	King Subdivision	1,265	4.16	0.13	Y	Group Together	To Robindale Sewage Treatment Plant	\$2,775,000	
12B	Barrio Subdivision	389	1.39	0.04	Y				
17B	Saldivar (II)	272	1.70	0.03	Y				
20B	Unnamed D (Keller's)	243	2.27	0.02	Y				
21B	Texas 4	243	1.52	0.02	Y				
23B	Illinois Heights	204	1.68	0.02	Y				
26B	Unknown	117	0.63	0.01	Y				
27B	Unknown B (Hwy 802)	97	1.91	0.01	Y				
6B	Alabama/Arkansas	1,022	0.86	0.10	Y	Group Together	To South Sewage Treatment Plant	\$1,860,000	
16B	Unknown	282	1.93	0.03	Y				
18B	Villa Escondido	272	1.47	0.03	Y				
25B	Villa Hermosa	126	1.37	0.01	Y				
7B	Hacienda Gardens	944	3.78	0.09	Y	Wastewater Treatment Plant	Robindale Sewage Treatment Plant	\$965,000	
9B	Villa Pancho	603	1.66	0.06	Y	Group Together	To South Sewage Treatment Plant	\$2,445,000	
10B	Pleasant Meadows	584	2.90	0.06	Y				
13B	Los Cuates	379	1.71	0.04	Y				
15B	Coronado	302	1.11	0.03	Y				
22B	511 Crossroads	243	1.72	0.02	Y				
24B	Unkn. (Braville Air.)	195	1.90	0.02	Y				
28B	21	88	2.00	0.01	Y				
14B	Saldivar	302	1.41	0.03	Y	Wastewater Treatment Plant	Robindale Sewage Treatment Plant	\$310,000	
19B	Unnamed C	263	2.25	0.03	Y	Wastewater Treatment Plant	South Sewage Treatment Plant	\$270,000	

TABLE 10 (continued)  
**Wastewater Collection, Treatment And Disposal Options  
for The Colonias of Cameron County, Texas**

CAMERON COUNTY REGIONAL PLANNING STUDY  
RECOMMENDATIONS AND IMPLEMENTATION SCHEDULE

Colonia		Year 2020			Sewered (Y/N)	Recommended Treatment Method	Recommended Disposal Method	Total Cost
Desig.	Name	Pop.	Unit Density (1/Ac)	WW Gen. (MGD)				
1W	Encantada	1,641	1.56	0.16	Y	Group Together	Own Treatment Plant	\$2,140,292
9W	El Calaboz	260	3.17	0.03	Y			
2W	Santa Maria	2,306	5.89	0.23	Y	Group Together	Own Treatment Plant	\$1,722,737
10W	Iglesia Antigua	206	4.20	0.02	Y			
3W	La Paloma	861	2.48	0.09	Y	Individual Collection /Treatment System	Own Treatment Plant	\$1,007,333
4W	Los Indios	699	1.43	0.07	Y	Individual Collection /Treatment System	Own treatment plant	\$878,695
5W	Bluetown	580	2.00	0.06	Y	Individual Collection /Treatment System	Own Treatment Plant	\$540,243
6W	T2 Unknown Subd.	431	1.96	0.04	Y	Group Together to Santa Rosa	Santa Rosa's Collection System	\$1,042,403
13W	Q Unknown Subd.	241	3.06	0.02	Y			
15W	R Unknown Subd.	196	1.60	0.02	Y			
17W	S	116	0.96	0.01	Y			
7W	El Venadito	287	1.44	0.29	N	On-Site System	Mounded Pressure -dose System	\$295,000
8W	Carricitoa-Londrum	275	0.48	0.03	N	On-Site System	Mounded Pressure -dose System	\$280,000
11W	Palmer	285	1.81	0.03	Y	Individual Collection /Treatment System	Own Treatment Plant	\$409,988
12W	Unknown (Mitia 2)	169	1.06	0.17	N	On-Site System	Mounded Pressure -dose System	\$170,000
14W	W	137	0.58	0.14	N	On-Site System	Mounded Pressure -dose System	\$140,000
16W	X Unknown Subd.	116	1.50	0.01	N	On-Site System	Mounded Pressure -dose System	\$120,000
1E	La Coma del Norte	868	1.77	0.09	Y	Group Together	Own Treatment Plant	\$2,035,280
4E	Laureles	381	1.34	0.04				
8E	Unknown	262	3.31	0.00				
12E	25	75	0.47	0.01				
13E	Cisneros	144	1.44	0.01				
2E	Lozano	680	2.78	0.01	Y	Individual Collection /Treatment System	Own Treatment Plant	\$765,488
3E	La Tina Ranch	662	2.29	0.01	Y	Individual Collection /Treatment System	Own Treatment Plant	\$779,984
5E	Del Mar Heights	483	0.48	0.05	N	On-Site System	Mounded Pressure -dose System	\$790,000
10E	Unknown (Del Mar II)	290	0.95	0.03	N			
6E	Orason/Chula Vista	464	0.45	0.05	N	On-Site System	Mounded Pressure -dose System	\$475,000
7E	Las Yescas	281	3.56	0.00	Y	Individual Collection /Treatment System	Own Treatment Plant	\$355,496
9E	Glenwood Acres Subd.	218	1.41	0.02	N	On-Site System	Mounded Pressure -dose System	\$225,000
11E	Los Cuates	261	2.41	0.03	Y	Individual Collection System	To Los Fresnos' Collection System	\$439,666
1H	Las Palmas	1,103	2.88	0.11	Y	Individual Collection System	Harlingen Collection System	\$860,267
2H	Lago Subd.	695	3.46	0.07	Y	Group Together	San Benito Collection System	\$1,042,819
5H	Rice Tracts	234	1.50	0.02	Y			
3H	26	504	2.51	0.05	Y			
4H	Lasana	217	2.00	0.02	Y	Individual Collection System	Harlingen Collection System	\$477,516
6H	Leal Subd.	217	1.83	0.02	Y	Individual Collection System	Harlingen Collection System	\$285,079
7H	Laguna Escondido	95	1.10	0.01	N	On-Site System	Mounded Pressure -dose System	\$95,000

- The CCWDB should begin preparation of a screening mechanism to rate the colonias of Cameron County on severity of need.
- The CCWDB should begin preparation of applications for Phase I Engineering funding from the TWDB for the most severely distressed colonias.

## 11.0 REFERENCES

Audrey's data on ethnicity, gender in Cameron County

Blair, W. F. 1950. The Biotic Province of Texas. Texas Journal of Science 2:93-117.

Bowles, William F. Intensive Survey of the Brownsville Ship Channel (Segment 2494), Report IS-55. Texas Department of Water Resources. Austin, Texas (August, 1983).

Bowles, William F., Jr. Bacteriological Water Quality of the Arroyo Colorado (Segment 2201), Report LP86-05. Texas Water Commission, Austin, Texas (July, 1986).

Bureau of Economic Geology, 1976, Geologic Atlas of Texas; The University of Texas at Austin.

Cameron County Program Development and Management Department. 1986 Cameron County Colonia Re-Development Study

Davis, Jack R. Intensive Survey of the Arroyo Colorado Segment 2201, Report IS-61. Texas Department of Water Resources. Austin, Texas (May, 1984).

Davis, Jack R. Intensive Survey of the Arroyo Colorado Segment 2201, Report IS-69. Texas Department of Water Resources. Austin, Texas (January, 1985).

Davis, Jack R. Intensive Survey of the Arroyo Colorado Segment 2201. Report IS-49. Texas Department of Water Resources. Austin, Texas (April, 1983).

Gould, F. W. 1975. Texas Plants: A Checklist and Ecological Summary. Texas A&M University Press. College Station, Texas.

Holz, Robert K. and Shane Davies. August 1989. Third World Texas: Colonias in the Lower Rio Grande Valley. A Report Submitted to The Policy Research Center. The LBJ School of Public Affairs. The University of Texas at Austin.

Low Energy Membrane Nanofiltration for Removal of Color, Organics, and Hardness from Drinking Water Supplies, B. M. Watson et al, Kuwait Symposium on Management and Technology of Water Resources in Arid Zones, 1987

Lower Rio Grande Development Council. 1988. Population Projections for Selected Rural Unincorporated Communities in Cameron, Hidalgo and Willacy Counties (1980-2005).

Membrane Softening - The Concept and Application to Municipal Water Supply, William J. Conlon, P.E., et al, 4th World Congress on Desalination and Water Use, 1989, Kuwait

Orton, R. B., 1977. National Weather Service, Cameron County Soil Survey, U.S.D.A. Soil Conservation Service.

R. W. Beck and Associates, Inc. 1988. Brownsville Public Utilities Board - 1988 Wastewater Master Plan.

Rauschuber, D. G. and M.P. Sullivan. March 1989. Environmental Inventory and Issues Report, Rio Grande Valley Water Conservation Project. Prepared for Rio Grande Valley Municipal Water Authority and Public Utilities Board of Brownsville.

Rauschuber, D. G. and R. J. Brandes. April 1989. Technical Report - Operations Study Rio Grande Valley Water Conservation Project. report No. 03-02. Prepared for Rio Grande Valley Municipal Water Authority and Public Utilities Board of Brownsville. 5 Vols. Austin, Texas.

SCS data on Cameron County

Sellards, E. H., Akins, W. S., Plummer, F. B., 1981. The Geology of Texas: Bureau of Economic Geology.

- Skillem, Frank F. 1988. Texas Water Law Volume I. Sterling Press Incorporated, San Antonio, Texas.
- Texas A&M University. 1987. Estimates of the Total Population of Counties in Texas By Age, Sex and Race/Ethnicity for July 1, 1987.
- \_\_\_\_\_. 1988. Projections of the Population of Texas and Counties in Texas By Age, Sex and Race/Ethnicity for 1990-2025, December 1988.
- \_\_\_\_\_. 1988. Estimates of Population for Cameron, Hidalgo and Willacy Counties.
- Texas Board of Water Engineers. May 1960. Bulletin 6008-Water Levels in Observation Wells in Cameron, Hidalgo, and Starr Counties Texas 1950-1959. Austin, Texas.
- Texas Department of Commerce. November 1988. Estimates of the Total Population of Counties in Texas by Age, Sex, and Race/Ethnicity for July 1, 1987. Prepared by the Department of Rural Sociology, Texas Agricultural Experiment Station, Texas A&M University.
- Texas Department of Health. 1988. Rules & Regulations For Public Water Systems.
- Texas Department of Health. Construction Standards For On-Site Sewerage Facilities. January 1, 1990.
- Texas Department of Health. November 1977. Construction Standards For Private Sewage Facilities.
- Texas Department of Human Services. June 1988. The Colonias Fact Book.
- Texas Department of Water Resources. July 1979. Report 236-Stratigraphic and Hydrogeologic Framework Of Part Of The Coastal Plain of Texas. Austin, Texas.
- Texas Department of Water Resources. September 1983. Report 279-Occurrence and Quality of Ground Water in the Vicinity of Brownsville, Texas.
- Texas Department of Water Resources. Waste Load Evaluation For The Arroyo Colorado In The Nueces-Rio Grande Coastal Basin. Austin, Texas (draft, May 13, 1985).
- Texas Department of Water Resources. Water For Texas. 2 Vols. Austin, Texas. November 1984.
- Texas Education Agency. 1988. Cameron County School Enrollment Data (1984-1988).
- Texas Employment Commission 1985-1989. Annual Average Labor Force Estimates for Texas Counties. Austin, Texas.
- Texas Natural Heritage Program. 1989. Sensitive Species and Natural Communities within Cameron County, Texas.
- Texas Water Commission. 1989. Rules, Regulations and Design Criteria For Sewerage Systems.
- Texas Water Commission. Methodology. Compiled by the Modeling Unit of the Water Quality Standards and Evaluation Section, Austin, Texas.
- Texas Water Commission. The State of Texas Water Quality Inventory, 9th Edition, Report LP88-04. Austin, Texas (April, 1988).
- Texas Water Development Board. A Summary Of The Preliminary Plan For Proposed Water Resources Development in the Rio Grande Basin. Austin, Texas. August 1966.
- Texas Water Development Board. Continuing Water Resources Planning and Development for Texas - Draft. 2 Vols. Austin, Texas. May 1977.
- Texas Water Development Board. The Texas Water Plan. Austin, Texas. November 1968.

Texas Water Development Board. Water For Texas: Today and Tomorrow - Draft. Austin, Texas. July 1990.

Twidwell, Steve R. Intensive Surface Water Monitoring Survey for Segment 2201, Report IMS-72. Texas Department of Water Resources. Austin, Texas (reprinted March, 1984).

U. S. Department of Commerce, Bureau of the Census. 1986. Population estimates, 1984 and per capita income, 1983. Series P-26.

U. S. Department of Commerce. 1987. Local Area Personal Income 1982-1987

U. S. Department of Interior. Bureau of Reclamation. September 1956. Availability of Ground Water In The Gulf Coast Region Of Texas - Open File Report. Austin, Texas.

U. S. Environmental Protection Agency. On-Site Wastewater Treatment and Disposal Systems. Design Manual. October 1980.

U. S. Environmental Protection Agency. Wastewater Treatment Facilities For Sewered Small Communities. EPA-625/1-77-009. Process Design Manual. October 1977.

U. S. Soil Conservation 1980. Land Use By Type For Cameron County.

U. S. Soil Conservation Service, Soil Survey for Cameron County, Texas.

Use of Membrane Technology in Florida, Glenn M. Dykes, P.E., Administrator, Water Supply Section, Florida Department of Environmental Regulation, and William J. Conlon, P.E., Vice-President, Stone and Webster Water Technology Services

Williams, D., Thompson, C.M., Jacobs, J.L., 1977. Cameron County Soil Survey: U.S.D.A., Soil Conservation Service.

August 29, 1991

Dr. Tommy Knowles, Director of Planning  
Texas Water Development Board  
P.O. Box 13231 Capitol Station  
Austin, Texas 78711-3231

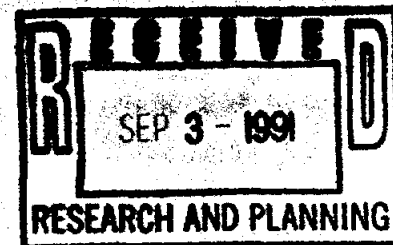

Re: Response to Letter of July 31, 1991 to  
The Honorable Antonio Garza, Jr., Cameron County Judge  
Review Comments to TWDB Contract No. 9-483-733  
Cameron County Regional Water and Wastewater Planning Study

Dear Dr. Knowles:

The following responses are presented pursuant to your supplemental comments.

**Response to Comment 5.**

We concur with staff's comment that "...certain on-site systems have been shown to operate effectively under conditions such as exist in Cameron County". As such, recommendations for the use of on-site technologies were made in the original draft of the study. Table 10-1 summarizes recommended wastewater disposal methods for the colonias evaluated. On-site technologies were recommended for nine of the colonias. At the level which this study was performed, it was not possible to make lot-by-lot determinations for the suitability of on-site technologies. Based on more intensive site analyses for specific areas, on-site technologies may be found to be appropriate and the preferred method of disposal.

**Response to Comment 8.**

The attached Figures A-1 and A-2 summarize, in chart form, data contained in the 1987 Turner Collie & Braden/Texas Water Development Board (TCB/TWDB) study entitled "A Reconnaissance Level Study of Water Supply and Wastewater Disposal Needs of the Colonias of the Lower Rio Grande Valley". Appendix A-4 of the TCB/TWDB study identified estimated capital and operating and maintenance costs for providing wastewater treatment to 39 individual colonias in Cameron County. The 39 colonias fell into Classifications 1, 2, and 3, as defined in the TCB/TWDB study. The wastewater treatment methods evaluated included a generic oxidation pond system and a generic activated sludge treatment system. Figure A-1 summarizes estimated total capital costs based on projected average daily wastewater flows for each of the 39 colonias. Figure A-2 summarizes estimated annual operating and maintenance costs for the treatment systems evaluated. Data contained in the TCB/TWDB study was utilized to form the basis of our recommendations. The TCB/TWDB data presented the most comprehensive database from which to develop our recommendations. In all flow categories, oxidation pond systems were found to be the most cost-effective method of providing the levels of treatment anticipated for the projected wastewater flows for the colonias which these systems were recommended.

Subsequent to submittal of the the Draft Cameron County study, we have been involved in attempting to summarize unit cost estimates for various other treatment technologies, including constructed wetlands. At the time the Draft Cameron County study was submitted, the Texas Water Commission had not adopted final rules concerning design of constructed wetlands. Data on construction costs and operations and maintenance costs for constructed wetlands in Texas is limited due to the minimal number of systems in operation. In an effort to develop a basic understanding of the costs associated with constructed wetlands, we contacted Mr. Andrew Cueto, P.E. (a) of the Texas Water Commission. Mr. Cueto was very helpful in providing us with cost information which he had collected during his work on developing design criteria for constructed wetlands. A summary of the information which was made available to us is presented in the attached Tables A-1 through A-8.



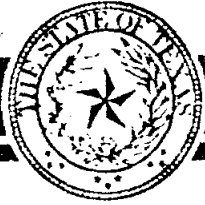

# TEXAS WATER DEVELOPMENT BOARD

Charles W. Jenness, *Chairman*  
Thomas M. Dunning, *Member*  
Nue Fernandez, *Member*

Craig Pedersen,  
*Executive Administrator*

Wesley F. Pittman, *Executive Director*  
William B. Madden, *Member*

July 31, 1991

The Honorable Antonio Garza, Jr.  
Cameron County Judge  
904 E. Harrison  
Brownsville, Texas 78540

Dear Judge Garza:

Re: TWDB Contract No. 9-433-733: Cameron County Regional Water and Wastewater Planning Study

The Texas Water Development Board has received Michael P. Sullivan's letter of July 26, 1991, responding to comments on subject study contained in our letter of November 7, 1990. We have reviewed Mr. Sullivan's responses, and find that all review comments have been adequately addressed except for comments 5, 8, and 11. These numbers refer to Water Development Board comments, which are consistently numbered in both our original letter and Mr. Sullivan's July 26, 1991 letter.

We would appreciate your reconsidering the responses to these three items, and making some adjustments which should allow the local perspective to be maintained, while adequately addressing contract requirements. Bold type shows our original comment, with additional comments/responses in regular type below.

5. Page 5-1 contains the statement that **"The consensus among Cameron county governmental and regulatory officials is that all septic systems will eventually fail and that, from a public health viewpoint, they should be avoided."** The Board's staff believes that the statement lacks accuracy and that the logic that septic systems should be avoided because they eventually fail is defective. According to Texas Department of Health estimates, as many as 4,000,000 Texans rely on on-site systems for sewage treatment and disposal, and most of these individuals are being adequately serviced by on-site systems. Septic systems and other on-site systems which meet the present day standards are viable alternatives and, in many cases, offer the most cost-effective means of handling the wastewater. Accordingly, the Board's staff recommends that the applicability of the sentence be reconsidered and modified appropriately.



There certainly was no intention on the part of the Board's staff to minimize or trivialize the viewpoint of local officials who are very close to the situation. We concur that most conventional on-site septic systems are not appropriate for the Cameron County area. However, as numerous studies have shown, mound systems, pressure-dosed systems, and other nonconventional on-site systems operate very effectively with a high ground water table, such as exists in Cameron County. We note that in Mr. Sullivan's analysis of alternative systems, a pressure-dosed mound system was included as an alternative. Accordingly, while certainly acknowledging the preference of local officials for centralized wastewater treatment, and concurring that conventional on-site systems are not generally applicable in Cameron County, we believe this section should at least note that certain on-site systems have been shown to operate effectively under conditions such as exist in Cameron County.

8. The draft report does not appear to provide an actual cost effectiveness analysis of alternatives. Instead, tables 5-10, 5-12, 5-15, and 5-18 only present initial capital costs of two alternatives for each colonia. An acceptable cost comparison would need to include operation and maintenance costs, salvage values, and other costs factors presented in terms of present worth values (or equivalent annual costs) and to detail any overriding social and environmental costs. It also appears that the costs for conventional sewers in the tables do not include the costs of house laterals. The cost for on-site systems needs to be revised because it appears to assume that every single system would have to be replaced. This assumption is probably not valid considering that only about 15 percent of the systems are having problems according to the estimate given on page 5-1 of the report. Without a complete cost-effectiveness analysis of alternatives, the recommendations in table 10-1 can only be considered unsubstantiated.

A cost effective analysis, which is required by our contract with Cameron County, requires the comparison of both construction, operating, and maintenance costs to determine a recommended system, rather than assuming a recommended system, and then calculating the cost. While we certainly do not expect individual alternatives to be prepared for each possibility within Cameron County, it seems appropriate to compare at least two different treatment technologies, for example, facultative lagoons and an alternative treatment system such as artificial wetlands, or rock reed filters. Please review this particular section, and see if it can be revised so as to actually show comparative costs between at least two different treatment systems. Use of a standard per lot cost for the on-site alternative seems reasonable.

11. Several water supply alternatives are proposed, but a recommendation is not given, and the names of users who might need additional supplies were not provided.

Although we concur that a detailed analysis of the adequacy of water supplies in Cameron County is beyond the scope of the study, a planning recommendation that a particular unincorporated area receive water from a water supplier which may not have capacity to supply this water seems inconsistent, even in a study of limited specificity, such as this one. We suggest that you simply check with the proposed suppliers, and include a statement as to the ability of that supplier to meet the demands of the recommended option.

July 31, 1991

Page Three

We appreciate the response to our comments, and those of the Texas Water Commission. While we certainly do not wish to burden you with details that are unnecessary and redundant, we believe that these three remaining items should be addressed prior to acceptance of the planning report for Cameron County if it is to be consistent with the body of engineering knowledge that is available today, our contract with Cameron County, and if it is to be useful to the County for future planning purposes.

If you have questions, or wish to discuss it further, please let us know.

Sincerely,

A handwritten signature in black ink, appearing to read "Tommy Knowles". The signature is written in a cursive, flowing style.

Tommy Knowles  
Director of Planning

cc: Mr. Michael P. Sullivan, P.E.

July 31, 1991

Brittin GBB 7-31-91  
Bond (S)  
Knowles JR 7/31/91

The Honorable Antonio Garza, Jr.  
Cameron County Judge  
904 E. Harrison  
Brownsville, Texas 78540

Dear Judge Garza:

Re: TWDB Contract No. 9-483-733: Cameron County Regional Water and Wastewater  
Planning Study

The Texas Water Development Board has received Michael P. Sullivan's letter of July 26, 1991, responding to comments on subject study contained in our letter of November 7, 1990. We have reviewed Mr. Sullivan's responses, and find that all review comments have been adequately addressed except for comments 5., 8., and 11. These numbers refer to Water Development Board comments, which are consistently numbered in both our original letter and Mr. Sullivan's July 26, 1991 letter.

We would appreciate your reconsidering the responses to these three items, and making some adjustments which should allow the local perspective to be maintained, while adequately addressing contract requirements. Bold type shows our original comment, with additional comments/responses in regular type below.

5. Page 5-1 contains the statement that "The consensus among Cameron county governmental and regulatory officials is that all septic systems will eventually fail and that, from a public health viewpoint, they should be avoided." The Board's staff believes that the statement lacks accuracy and that the logic that septic systems should be avoided because they eventually fail is defective. According to Texas Department of Health estimates, as many as 4,000,000 Texans rely on on-site systems for sewage treatment and disposal, and most of these individuals are being adequately serviced by on-site systems. Septic systems and other on-site systems which meet the present day standards are viable alternatives and, in many cases, offer the most cost-effective means of handling the wastewater. Accordingly, the Board's staff recommends that the applicability of the sentence be reconsidered and modified appropriately.

There certainly was no intention on the part of the Board's staff to minimize or trivialize the viewpoint of local officials who are very close to the situation. We concur that most conventional on-site septic systems are not appropriate for the Cameron County area. However, as numerous studies have shown, mound systems, pressure-dosed systems, and other nonconventional on-site systems operate very effectively with a high ground water table, such as exists in Cameron County. We note that in Mr. Sullivan's analysis of alternative systems, a pressure-dosed mound system was included as an alternative. Accordingly, while certainly acknowledging the preference of local officials for centralized wastewater treatment, and concurring that conventional on-site systems are not generally applicable in Cameron County, we believe this section should at least note that certain on-site systems have been shown to operate effectively under conditions such as exist in Cameron County.

8. **The draft report does not appear to provide an actual cost effectiveness analysis of alternatives. Instead, tables 5-10, 5-12, 5-15, and 5-18 only present initial capital costs of two alternatives for each colonia. An acceptable cost comparison would need to include operation and maintenance costs, salvage values, and other costs factors presented in terms of present worth values (or equivalent annual costs) and to detail any overriding social and environmental costs. It also appears that the costs for conventional sewers in the tables do not include the costs of house laterals. The cost for on-site systems needs to be revised because it appears to assume that every single system would have to be replaced. This assumption is probably not valid considering that only about 15 percent of the systems are having problems according to the estimate given on page 5-1 of the report. Without a complete cost-effectiveness analysis of alternatives, the recommendations in table 10-1 can only be considered unsubstantiated.**

A cost effective analysis, which is required by our contract with Cameron County, requires the comparison of both construction, operating, and maintenance costs to determine a recommended system, rather than assuming a recommended system, and then calculating the cost. While we certainly do not expect individual alternatives to be prepared for each possibility within Cameron County, it seems appropriate to compare at least two different treatment technologies, for example, facultative lagoons and an alternative treatment system such as artificial wetlands, or rock reed filters. Please review this particular section, and see if it can be revised so as to actually show comparative costs between at least two different treatment systems. Use of a standard per lot cost for the on-site alternative seems reasonable.

11. **Several water supply alternatives are proposed, but a recommendation is not given, and the names of users who might need additional supplies were not provided.**

Although we concur that a detailed analysis of the adequacy of water supplies in Cameron County is beyond the scope of the study, a planning recommendation that a particular unincorporated area receive water from a water supplier which may not have capacity to supply this water seems inconsistent, even in a study of limited specificity, such as this one. We suggest that you simply check with the proposed suppliers, and include a statement as to the ability of that supplier to meet the demands of the recommended option.

July 31, 1991  
Page Three

We appreciate the response to our comments, and those of the Texas Water Commission. While we certainly do not wish to burden you with details that are unnecessary and redundant, we believe that these three remaining items should be addressed prior to acceptance of the planning report for Cameron County if it is to be consistent with the body of engineering knowledge that is available today, our contract with Cameron County, and if it is to be useful to the County for future planning purposes.

If you have questions, or wish to discuss it further, please let us know.

Sincerely,

Tommy Knowles  
Director of Planning

cc: Mr. Michael P. Sullivan, P.E.



July, 26, 1991

Dr. Tommy Knowles, Director of Planning  
Texas Water Development Board  
P.O. Box 13231 Capitol Station  
Austin, Texas 78711-3231

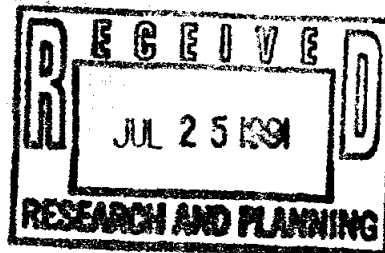

Re: Response to Letter of November 7, 1990  
Review Comments to TWDB Contract No. 9-483-733  
Cameron County Regional Water and Wastewater Planning Study

Dear Mr. Knowles:

This letter shall serve as a formal response to the comments contained in your November 7, 1990 letter regarding the Review of Draft Final Report for TWDB Contract No. 9-483-733, Cameron County Regional Water and Wastewater Planning Study (the Study). In order to insure a continuity between the original staff comments and our responses, the comments are presented in *bold italics* with the response following. The comments are presented in the order in which they occur in your letter.

#### Texas Water Development Board Comments

1. *The final report needs to be amended to fully satisfy the scope of work detailed in TWDB Contract No. 9-483-733.*

With the incorporation of these responses to comments we hope that the scope of work will be satisfactorily addressed. Where we concurred with staff comments, changes have been incorporated into the report text. Where we do not concur, explanation is supplied in this letter.

2. *Population and water demand projections utilized in the report are adequate for planning purposes.*

No response required.

3. *The wastewater flow projections of chapter 3 are based on 100 gallons per capita per day. This rate is significantly higher than what is expected for a bedroom type community such as a colonia. EPA studies into domestic water uses indicate that middle income residents typically generate 60 to 80 gpcd of sewage. This historical range does not account for reductions available through a good water conservation program. Data available to the TWDB's Water Uses and Projections section indicate that total water consumption in the rural areas of Cameron County are in the range on 90 gallons per capita per day. The sewage would be expected to be 90% or less of that. Since alternative identification is so dependant on flow rates, the report should reconsider the appropriateness of the 100 gpcd in light of existing rates and water conservation options. A 10% to 20% change in the flows may change the alternatives, and economic rankings.*

The use of 100 gpcd for wastewater design flows is consistent with accepted engineering practice and State design criteria for wastewater collection and treatment systems. The recently constructed 390,000 gpd wastewater treatment facility in Santa Rosa (funded through the Texas Department of Commerce) was designed based on a design flow of 100 gpcd. Information which we have obtained through the review of sanitary surveys of water purveyors in the Lower Rio Grande area (performed by the

Texas Department of Health) indicate a wide range of water use patterns. Current sanitary survey results are summarized below:

**Summary of Sanitary Surveys for Typical Rural Areas of  
the Lower Rio Grande Valley**

System Name	Population Served	Average Daily Usage (gpd)	Average Daily Per Capita Usage (gpcd)
City of Lyford	1,900	225,000	118
Port Mansfield PUD	734	75,000	102
Sunny Dew WSC	306	36,000	118
City of Raymondville	9,348	1,545,000	165
Santa Rosa WCID	238,000	1,889	126
Sebastian WSC	1,565	116,000	74

Using these figures, the average daily per capita water usage is estimated to be approximately 117 gallons. Table 3-1 of the Study lists TWDB population projections (low series and high series) for municipalities in Cameron County through 2020. Table 3-8 lists projected municipal water demands for the high per capita TWDB water use series with and without water conservation. Development of projected populations and water use for the Study was based on TWDB high series population projections and TWDB high water use series with water conservation. Combining the population and projected water use figures found in Tables 3-2 and 3-9, average daily water use projections for 'unincorporated' areas are estimated to be 143 gpcd for planning year 1990 and 125 gpcd for planning year 2020. Thus, for the purposes of the Study, we feel that the use of 100 gpcd is appropriate.

- 4. Page 5-10 of the report states that 'per capita (water) use rates are expected to increase dramatically and eventually approach statewide averages,' and according to John Bruclak of Brownsville's' PUB, 'water use rates have shown a marked increase in areas where city services have been improved.' First, the Board staff expects water use to approach the county or regional average rather than the statewide average, and further, the report should also recognize that the 10-year regional trend for South Texas is a decreasing consumption rate. Secondly, because the Board lacks data on the long-term water use changes in colonias after adequate water and wastewater services are provided, the contractor should quantify in the report the increases that John Bruclak reports as having occurred after the PUB has provided city services to a colonia.*

Prior to commencement of the study, discussions were held with Mr. James T. Fries (then Contract Administrator for TWDB). The wide disparity of water use rates in the Lower Rio Grande Valley were discussed and all agreed that a water use rate of 125 gpcd and a wastewater generation rate of 100 gpcd were appropriate for the county-wide planning level study.

The anecdotal reference to water use rates attributed to Mr. Bruclak is an opinion based on his personal and professional experience in the area and will remain as it was originally stated without further clarification. The water use projections used throughout the Study are based on TWDB high population series/high water use series estimates with water conservation.

- 5. Page 5-1 contains the statement that 'The consensus among Cameron County governmental and regulatory officials is that all septic systems will eventually fail and that, from a public health viewpoint, they should be avoided.' The Board's*



**staff believes that the statement lacks accuracy and that the logic that septic systems should be avoided because they eventually fail is defective. According to Texas Department of Health estimates, as many as 4,000,000 Texans rely on on-site systems for sewage treatment and disposal, and most of these individuals are being adequately serviced by on-site systems. Septic systems and other on-site systems which meet the present day standards are viable alternatives and, in many cases, offer the most cost-effective means of handling the wastewater. Accordingly, the Board's staff recommends that the applicability of the sentence be reconsidered and modified appropriately.**

Although the comment summarizes the feelings of numerous individuals in County and local government, the comment may be more directly attributed to Mr. Ray Rodriguez, R.S, Chief Sanitarian for the Cameron County Environmental Health Department. The comment is based on Mr. Rodriguez' extensive personal and professional experience in the County and should not be minimized or trivialized by Board's staff. County health officials rarely have problems with systems which are properly designed and constructed. The problem is that most of the on-site systems in Cameron County are improperly constructed and if not failing now, are destined to fail prematurely, when compared to properly constructed and maintained systems. The reasons for this include: less than adequate lot size; improper use and maintenance of the systems; dwelling densities typically far in excess of 2 units per acre; and inadequate drainage. Environmental Assessments and Wastewater Assessments, performed by the Texas Department of Health in Cameron County and Willacy County, support the observation that on-site wastewater disposal systems are inappropriate under conditions common to colonias in the Lower Rio Grande Valley.

- 6. Table 5-4 Incorrectly lists the City of Harlingen's wastewater treatment capacity at 3.6 mgd because the capacity of plant number 1 was excluded. The table identifies five (5) mgd capacity for the Brownsville PUB as existing even though construction has not yet started. Therefore, the table should be corrected.**

We concur with the comment. A corrected version of the table has been included in the final report.

- 7. The study does not appear to consider innovative and non-conventional alternatives for the colonias, which is a prerequisite for the Board to fund the construction of wastewater treatment facilities. If the regional report is to be used in conjunction with requests for financial assistance for colonia facilities, innovative and non-conventional alternatives need to be presented and assessed in the report.**

The Study is not intended as an Economically Distressed Areas Program Phase I Facility Engineering Plan. The Study is intended to serve as a long-term regional planning tool. Funds for construction of wastewater treatment facilities are not being sought as part of the Study. Specific studies meeting the requirements of the various State and Federal grant/loan assistance programs will be developed if and when funds are requested under those programs.

- 8. The draft report does not appear to provide an actual cost effectiveness analysis of alternatives. Instead, tables 5-10, 5-12, 5-15, and 5-18 only present initial capital costs of two alternatives for each colonia. An acceptable cost comparison would need to include operation and maintenance costs, salvage values, and other costs factors presented in terms of present worth values (or equivalent annual costs) and to detail any overriding social and environmental costs. It also appears that the costs for conventional sewers in the tables do not include the costs of house laterals. The cost for on-site systems needs to be revised because it appears to assume that every single system would have to be replaced. This assumption is probably not valid considering that only about 15 percent of the systems are having problems according to the estimate given on page 5-1 of the report. Without a complete cost-effectiveness analysis of**

***alternatives, the recommendations in table 10-1 can only be considered unsubstantiated.***

Based on consultations with local engineers, past engineering experience within the Water Resources Planning Group, and review of existing planning reports for the Lower Rio Grande Valley, it was determined that proposed wastewater treatment plant facilities would consist solely of facultative lagoons (where new facilities were required and projected wastewater flows were less than 300,000 gallons per day). Many systems of this variety exist in the vicinity. Under normal conditions, these plants are the least expensive to design, construct, operate, and maintain. Evaluation of more energy consumptive, high operations and maintenance cost systems, was considered unnecessary and redundant based on available information for the area.

The costs for house laterals have previously been included in the cost estimates for sanitary sewers under the item for 6-inch house connection.

It is difficult to provide an exact percentage for the number of on-site systems that are having problems in the colonias of Cameron County. Based on site visits to the colonias performed as part of this project, it was determined that a 'worst case' scenario would be appropriate for estimating projected costs for providing on-site systems. Conditions within the majority of colonias are unsuitable for proper construction, operation, and maintenance of on-site systems. Typical lot sizes for colonias which are located in platted subdivisions are typically less than 1/5-acre. The on-site disposal systems are typically overloaded. Grey water is discharged to the ground surface in order to reduce overall wastewater flows to the subsurface disposal system. Colonias which do not lie within a platted subdivision typically display similar housing densities. In order to insure that an artificially low value for providing adequate on-site systems was not presented in the Study, an average cost for providing a generic on-site system was applied to all dwellings. In approaching the issue in this manner, the costs associated with various on-site treatment technologies have been normalized, since it would be impossible at the level of this study to determine how many and which lots would be possible candidates of evapotranspiration systems, mound systems, absorption systems, pressure-dose systems, etc.

9. ***Although the water conservation recommendations made in Section 10 of the report are satisfactory, the specific comments for the water conservation portions of the study for individual tasks are as follows:***

**Task I.C.**

1. ***On page 3-16, the discussion at the top of the page implies that per capita water use figures for larger cities include industrial use, but TWDB per capita water use figures do not include industrial use. The inclusion of industrial use figures should be clarified, and if industrial use figures were included, they should be presented separately.***

The statement presented in the Study is accurate since large cities typically calculate per capita water usage based on total plant output, which includes sale to industrial customers. Texas Water Development Board per capita water use estimates do not include an industrial component. No connection was made in the referenced section of the report to the inclusion of industrial flows in TWDB water use projections.

2. ***Many of the tables in this section do not include units of water. For example, Table 3-7 on page 3-18 reports per capita water use but does not give the units. The correct units should be added to the tables.***

We concur with this comment and have provided revised tables which include all appropriate units.

3. *The statement that 'The TWDB estimates that about one-half of the water used for landscape irrigations during hot weather periods is wasted' in the third paragraph on page 4-11 should be modified to read that 'as much as on-half' rather than 'about one-half'.*

Page 4-11 has been revised to reflect this comment.

**Task II, B.&E.**

1. *The method used to incorporate water conservation into the wastewater projections is unclear. On page 3-22, Section 3.3 implies that a S/W ratio method was used, but when the S/W ratio was calculated based on water use from Table 3-11 and wastewater from Table 3-15, the resulting S/W ratio was 79. This is higher than the range quoted in Section 3.3. The figures should be checked, and the correct figure should be listed, and if necessary, the basis for the calculations should be explained.*

The range given for typical S/W ratios on page 3-22 of the report is one generally accepted by the engineering community and was intended to serve merely as a background for further discussions. Water use projections for unincorporated areas developed in the Study range from 143 gpcd in 1990 to 125 gpcd in 2020 and include water conservation practices. Wastewater generation projections are based on State design criteria (100 gpcd). The S/W ratio based on these values ranges from 0.70 to 0.80. The corresponding numbers in the final report have been corrected.

2. *As previously stated under Task I.C., several of the tables do not state units of water use.*

The referenced tables have been revised to indicate appropriate units.

**Task IV**

1. *The water conservation plan is excellent. The drought contingency portion of the plan is satisfactory, but individual utility plans would need to be activated if the drought contingency portions were to be implemented. The Board's staff understands that implementation is beyond the scope of the study.*

No response required.

2. *On page 6-6, the Water Rate Structure Section states that the PUB uses a "flat rate." According to American Water Works Association definitions, this rate should be called a "uniform rate."*

Your comment is noted and the term has been revised.

3. *The annual reporting requirement described on page 6-8 is not a requirement of the Regional Planning grant program, but such a report would be very useful to the TWDB staff and would be much appreciated.*

The referenced section does not state that the report is required. Submittal of the report is intended to be voluntary and for informational purposes only.

10. *The water supply portion of the study should be strengthened by an evaluation of the supply adequacy of the various water suppliers in the county.*

Numerous municipalities and water supply corporations supply water in the Lower Rio Grande Valley through an intricate and convoluted system of supply agreements, contracts, and other instruments. Tracking the adequacy of existing supplies, future options, and agreements is virtually impossible and beyond the scope of this study. The overall supplies in the Lower Rio Grande Valley are agreed to be generally inadequate to meet future demands; however, identification of specific sources with specific suppliers is beyond the scope of this study.

11. *Several water supply alternatives are proposed, but a recommendation is not given, and the names of users who might need additional supplies were not provided.*

The scope of the Study focused on the needs of the unincorporated areas of Cameron County. No effort was made to assess the future supply adequacy of incorporated municipalities and water supply corporations.

12. *A detailed analysis was done for the colonias in terms of who would supply which colonia. However, no analysis was presented as to whether the proposed suppliers have adequate water supplies to meet the additional needs or what additional supplies would need to be developed.*

Again, this is beyond the scope of the Study.

#### Texas Water Commission Comments

1. *Regarding population projections, the draft plan utilizes the TWDB High Series population projections to develop water and wastewater needs. The Lower Rio Grande Valley Development Council (LRGVDC) has developed population projections for the Texas Water Commission (report dated August 1989) which have recently been certified as updates to the State Water Quality Management Plan. The TWDB's and LRGVDC's population figures differ quite substantially for the Brownsville area in the year 2010. The Board's population is 197,616 in the year 2010, and the LRGVDC's projections for the year 2010 are 178,504 (median) or 179,787 (mean). This difference in population projections should be resolved, particularly if Brownsville applies for funding that requires consistency with the Water Quality Management Plan. The Board's and LRGVDC's total population figures for the rural (or unincorporated areas) are very similar.*

Use of TWDB population and water use projections is consistent with the scope of work and contract requirements of this project.

2. *LRGVDC's population figures in Table 3-1 on page 3-6 should be updated to reflect the LRGVDC's most recent August 1989 population report.*

This section of the Study has been revised to reflect staff's comment.

3. *Page 5-36, Second Paragraph*

*The seven-day two-year low flow (7Q2) for Segment 2202 is 6.0 ft/s.*

This section of the Study has been revised to reflect staff's comment.

4. **Page 5-36, Table 5-6**

**Dissolved oxygen criteria should read not less than 4.0 mg/l 24-hour average, 3.0 mg/l minimum.**

This section of the Study has been revised to reflect staff's comment.

5. **Page 5-37, Table 5-7**

**Dissolved oxygen criteria should read not less than 5.0 mg/l 24-hour average, 4.0 mg/l minimum.**

This section of the Study has been revised to reflect staff's comment.

6. **Page 5-37, Second Paragraph**

**The last statement is very poorly worded. It gives the impression that the normal standards do not apply when the flow equals or is greater than the 7Q2 flow. It should more clearly state that exceptions to numerical criteria apply when the flow is less than 7Q2.**

This section of the Study has been revised to reflect staff's comment.

7. **Page 5-38, Second Paragraph**

**There is no formal ranking of segments at this time by TWC in the 305(b) report. All references to segment ranking should be deleted on page 5-38. In addition, the report should clarify that advance treatment is not required for discharges to Segment 2201.**

This section of the Study has been revised to reflect staff's comment.

8. **Page 5-38, Third Paragraph**

**The statement..."no standard effluent limits apply to the entire segment and that new and renewal permit applications are reviewed on an individual and cumulative impact basis" applies to effluent-limited segments as well. Specific dissolved oxygen criteria have not been assigned to each individual tributary within segments based on observed uses. The criterion for these streams will be evaluated as a result of a Texas Water Commission Receiving Water Assessment, which is conducted in response to individual permit actions in unclassified waters. The report should state that, at such time, advanced treatment may be required of dischargers.**

This section of the Study has been revised to reflect staff's comment.

9. **Page 5-40, First Paragraph**

**The 5.0 mg/l criterion is 24-hour average.**

This section of the Study has been revised to reflect staff's comment.

10. **Page 5-41, Second Paragraph**

**The average DO criterion of the channel is 5.0 mg/l.**

This section of the Study has been revised to reflect staff's comment.

**11. Page 5-41, Second Paragraph**

**Tributary Impacts were not addressed. Refer to Comment 8 above from page 5-38 on tributary impacts. Higher treatment requirements are probable for the PUB plant.**

This section of the Study has been revised to reflect staff's comment.

**12. Page 5-41, Third Paragraph**

**The 10/15 permit should read 10/15/3 or 10/3, because the Harlingen plant permit has a nitrification requirement. The report should also state that the 4.0 mg/l DO criteria is a 24-hour average.**

This section of the Study has been revised to reflect staff's comment.

**13. Page 5-45**

**The 20/90 effluent quality should read 30/90.**

This section of the Study has been revised to reflect staff's comment.

**14. Page 7-10, Last Paragraph**

**Segment 2022 should be listed as Water Quality Limited.**

This section of the Study has been revised to reflect staff's comment.

**15. Page 7-11, Table 7-2**

**The table should state that uses for Segment 2202 include Intermediate Aquatic Habitat, and the DO criterion should include the a/ superscript. Further, the table shows that the uses for Segment 2302 include Public Water Supply.**

This section of the Study has been revised to reflect staff's comment.

**16. Page 7-12, First Paragraph**

**The reference to minimum dissolved oxygen criteria should be changed to average D.O. criteria.**

This section of the Study has been revised to reflect staff's comment.

The Water Resources Planning Group wishes to thank the Board and Commission staff members for their thoughtful comments and observations regarding the draft study. Please contact our office if you or your staff have questions regarding our responses to their comments.

Sincerely,

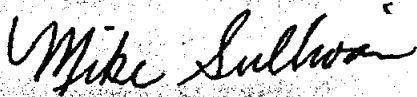

Michael P. Sullivan, Ph.D., P.E.  
President  
Michael Sullivan and Associates, Inc.

Cameron County Regional  
Water And Wastewater  
Planning Study  
Contract No. 9-483-733

The following maps are not attached to this report. They are located in the official file and may be copied upon request.

Map No. 1 – Facilities Map of Sub-Area E  
Figure 5-84

Map No. 2 Facilities Map of Sub-Area H  
Figure 5-50

Please contact Research and Planning  
Fund Grants Management Division at (512)  
463-7926 for copies.

Table 2-4  
Crystal Clear Water Supply Corporation Historical Use

Year	January			February			March			April			May			June		
	Self. a/	Purch. b/	Total	Self. a/	Purch. b/	Total	Self. a/	Purch. b/	Total	Self. a/	Purch. b/	Total	Self. a/	Purch. b/	Total	Self. a/	Purch. b/	Total
1967	17.7	0.0	17.7	7.3	0.0	7.3	14.4	0.0	14.4	9.1	0.0	9.1	10.5	0.0	10.5	13.4	0.0	13.4
1968	10.9	0.0	10.9	8.7	0.0	8.7	8.7	0.0	8.7	8.7	0.0	8.7	10.3	0.0	10.3	10.7	0.0	10.7
1969	10.0	0.0	10.0	9.0	0.0	9.0	9.1	0.0	9.1	9.1	0.0	9.1	9.5	0.0	9.5	10.9	0.0	10.9
1970	10.6	0.0	10.6	9.1	0.0	9.1	9.5	0.0	9.5	9.2	0.0	9.2	9.5	0.0	9.5	10.8	0.0	10.8
1971	11.3	0.0	11.3	10.3	0.0	10.3	12.1	0.0	12.1	12.3	0.0	12.3	13.3	0.0	13.3	13.7	0.0	13.7
1972	13.8	0.0	13.8	13.2	0.0	13.2	14.2	0.0	14.2	13.8	0.0	13.8	14.4	0.0	14.4	13.8	0.0	13.8
1973	14.4	0.0	14.4	12.9	0.0	12.9	14.4	0.0	14.4	14.0	0.0	14.0	14.6	0.0	14.6	14.2	0.0	14.2
1974	14.5	0.0	14.5	13.1	0.0	13.1	14.9	0.1	15.0	14.7	2.4	17.1	16.2	2.2	18.4	29.5	2.7	32.2
1975	14.2	0.2	14.4	15.6	0.2	15.8	17.5	0.2	17.7	16.8	0.2	17.0	18.2	0.5	18.7	19.5	1.1	20.6
1976	17.1	1.1	18.2	18.8	1.0	19.8	21.0	0.2	21.2	20.8	0.4	21.2	22.3	0.5	22.8	23.5	0.5	24.0
1977	18.9	1.0	19.9	23.7	2.2	25.9	24.5	1.7	26.2	21.2	0.7	21.9	25.1	0.3	25.4	23.5	0.6	24.1
1978	21.6	0.0	21.6	24.4	0.0	24.4	24.8	0.0	24.8	25.0	0.0	25.0	28.4	0.0	28.4	29.9	0.0	29.9
1979	24.2	0.0	24.2	25.1	0.0	25.1	25.1	0.0	25.1	28.7	0.0	28.7	31.8	0.0	31.8	36.3	0.0	36.3
1980	26.9	0.0	26.9	25.8	0.0	25.8	25.4	0.0	25.4	32.5	0.0	32.5	35.1	0.0	35.1	42.7	0.0	42.7
1981	28.4	0.0	28.4	28.0	0.0	28.0	34.5	0.0	34.5	19.1	0.0	19.1	35.2	0.0	35.2	37.6	0.0	37.6
1982	49.1	0.0	49.1	55.2	0.0	55.2	39.9	0.0	39.9	43.0	0.0	43.0	52.2	0.0	52.2	49.1	0.0	49.1
1983	51.9	0.0	51.9	66.0	0.0	66.0	77.0	0.0	77.0	49.1	0.0	49.1	58.3	0.0	58.3	54.7	0.0	54.7
1984	55.3	0.0	55.3	62.2	0.0	62.2	74.7	0.0	74.7	58.7	0.0	58.7	61.5	0.0	61.5	62.3	0.0	62.3
1985	58.7	0.0	58.7	58.5	0.0	58.5	72.5	0.0	72.5	68.2	0.0	68.2	64.7	0.0	64.7	69.9	0.0	69.9
1986	62.1	0.0	62.1	54.7	0.0	54.7	70.2	0.0	70.2	77.8	0.0	77.8	67.8	0.0	67.8	77.4	0.0	77.4
1987	65.5	0.0	65.5	50.9	0.0	50.9	67.9	0.0	67.9	87.3	0.0	87.3	71.0	0.0	71.0	85.0	0.0	85.0

Year	July			August			September			October			November			December		
	Self. a/	Purch. b/	Total	Self. a/	Purch. b/	Total	Self. a/	Purch. b/	Total	Self. a/	Purch. b/	Total	Self. a/	Purch. b/	Total	Self. a/	Purch. b/	Total
1967	17.7	0.0	17.7	20.9	0.0	20.9	13.3	0.0	13.3	10.2	0.0	10.2	9.1	0.0	9.1	9.6	0.0	9.6
1968	18.3	0.0	18.3	23.9	0.0	23.9	17.3	0.0	17.3	11.6	0.0	11.6	10.0	0.0	10.0	9.8	0.0	9.8
1969	15.2	0.0	15.2	20.5	0.0	20.5	17.6	0.0	17.6	11.8	0.0	11.8	10.5	0.0	10.5	9.8	0.0	9.8
1970	14.7	0.0	14.7	15.3	0.0	15.3	15.9	0.0	15.9	13.0	0.0	13.0	11.4	0.0	11.4	10.6	0.0	10.6
1971	15.4	0.0	15.4	14.7	0.0	14.7	14.3	0.0	14.3	14.6	0.0	14.6	13.9	0.0	13.9	14.3	0.0	14.3
1972	14.4	0.0	14.4	14.5	0.0	14.5	14.0	0.0	14.0	14.4	0.0	14.4	13.9	0.0	13.9	14.3	0.0	14.3
1973	14.7	0.0	14.7	14.7	0.0	14.7	14.1	0.0	14.1	14.5	0.0	14.5	13.9	0.0	13.9	14.2	0.0	14.2
1974	52.9	2.2	55.1	24.1	2.6	26.7	23.7	1.9	25.6	21.6	1.9	23.5	16.3	1.5	17.8	15.3	1.2	16.5
1975	23.6	1.2	24.8	28.4	1.5	29.9	25.3	0.8	26.1	25.9	0.8	26.7	22.0	0.8	22.8	19.9	0.7	20.6
1976	28.8	0.7	29.5	34.0	2.3	36.3	30.6	1.3	31.9	29.7	0.5	30.2	26.7	0.5	27.2	24.1	0.5	24.6
1977	30.1	1.9	32.0	35.8	0.9	36.7	49.1	0.4	49.5	37.7	0.1	37.8	28.2	0.0	28.2	27.2	0.5	27.7
1978	32.8	0.0	32.8	36.5	0.0	36.5	49.4	0.0	49.4	41.5	0.0	41.5	31.5	0.0	31.5	33.6	0.0	33.6
1979	35.4	0.0	35.4	37.2	0.0	37.2	49.7	0.0	49.7	45.2	0.0	45.2	34.9	0.0	34.9	40.0	0.0	40.0
1980	67.2	0.0	67.2	71.6	0.0	71.6	47.1	0.0	47.1	38.1	0.0	38.1	34.0	0.0	34.0	33.0	0.0	33.0
1981	43.5	0.0	43.5	31.5	0.0	31.5	46.4	0.0	46.4	44.6	0.0	44.6	37.8	0.0	37.8	31.5	0.0	31.5
1982	61.4	0.0	61.4	79.8	0.0	79.8	107.4	0.0	107.4	95.1	0.0	95.1	73.7	0.0	73.7	64.4	0.0	64.4
1983	54.6	0.0	54.6	96.4	0.0	96.4	73.4	0.0	73.4	87.3	0.0	87.3	65.5	0.0	65.5	57.1	0.0	57.1
1984	58.0	0.0	58.0	92.6	0.0	92.6	71.1	0.0	71.1	96.9	0.0	96.9	68.7	0.0	68.7	64.7	0.0	64.7
1985	61.4	0.0	61.4	88.9	0.0	88.9	68.9	0.0	68.9	106.4	0.0	106.4	71.9	0.0	71.9	72.3	0.0	72.3
1986	64.8	0.0	64.8	85.1	0.0	85.1	66.6	0.0	66.6	116.0	0.0	116.0	75.0	0.0	75.0	79.8	0.0	79.8
1987	133.8	0.0	133.8	129.0	0.0	129.0	96.6	0.0	96.6	92.8	0.0	92.8	76.6	0.0	76.6	86.3	0.0	86.3

a/ Self-Supplied Ground & Surface  
b/ Purchased from City of San Antonio



Table 2-4 (Continued)  
Crystal Clear Water Supply Corporation Historical Use

	Self-Supplied					Purchased					Total Used					No. Taps	Annual Use	
	Total AF	Max. AF	Min. AF	AF	Max/Avg.	Total AF	Max. AF	Min. AF	Avg. AF	Max/Avg.	Total AF	Max. AF	Min. AF	Avg. AF	Max/Avg.		AF/Tap	gal./Tap
1967	153.2	20.9	7.3	12.8	1.6	0.0	0.0	0.0	0.0	#DIV/0!	153.2	20.9	7.3	12.8	1.6	588	0.261	84.9
1968	148.9	23.9	8.7	12.4	1.9	0.0	0.0	0.0	0.0	#DIV/0!	148.9	23.9	8.7	12.4	1.9	600	0.248	80.9
1969	143.0	20.5	9.0	11.9	1.7	0.0	0.0	0.0	0.0	#DIV/0!	143.0	20.5	9.0	11.9	1.7	630	0.227	74.0
1970	139.6	15.9	9.1	11.6	1.4	0.0	0.0	0.0	0.0	#DIV/0!	139.6	15.9	9.1	11.6	1.4	670	0.208	67.9
1971	160.2	15.4	10.3	13.4	1.2	0.0	0.0	0.0	0.0	#DIV/0!	160.2	15.4	10.3	13.4	1.2	720	0.223	72.5
1972	168.7	14.5	13.2	14.1	1.0	0.0	0.0	0.0	0.0	#DIV/0!	168.7	14.5	13.2	14.1	1.0	796	0.212	69.1
1973	170.6	14.7	12.9	14.2	1.0	0.0	0.0	0.0	0.0	#DIV/0!	170.6	14.7	12.9	14.2	1.0	859	0.199	64.7
1974	256.8	52.9	13.1	21.4	2.5	18.7	2.7	0.0	1.6	1.7	275.5	55.1	13.1	23.0	2.4	941	0.293	95.4
1975	246.9	28.4	14.2	20.6	1.4	8.2	1.5	0.2	0.7	2.2	255.1	29.9	14.4	21.3	1.4	1025	0.249	81.1
1976	297.4	34.0	17.1	24.8	1.4	9.5	2.3	0.2	0.8	2.9	306.9	36.3	18.2	25.6	1.4	1138	0.270	87.9
1977	345.0	49.1	18.9	28.8	1.7	10.3	2.2	0.0	0.9	2.6	355.3	49.5	19.9	29.6	1.7	1175	0.302	98.5
1978	379.3	49.4	21.6	31.6	1.6	0.0	0.0	0.0	0.0	#DIV/0!	379.3	49.4	21.6	31.6	1.6	1305	0.291	94.7
1979	413.7	49.7	24.2	34.5	1.4	0.0	0.0	0.0	0.0	#DIV/0!	413.7	49.7	24.2	34.5	1.4	1383	0.299	97.5
1980	479.4	71.6	25.4	40.0	1.8	0.0	0.0	0.0	0.0	#DIV/0!	479.4	71.6	25.4	40.0	1.8	1479	0.324	105.6
1981	418.1	46.4	19.1	34.8	1.3	0.0	0.0	0.0	0.0	#DIV/0!	418.1	46.4	19.1	34.8	1.3	1541	0.271	88.4
1982	770.3	107.4	39.9	64.2	1.7	0.0	0.0	0.0	0.0	#DIV/0!	770.3	107.4	39.9	64.2	1.7	1700	0.453	147.7
1983	791.3	96.4	49.1	65.9	1.5	0.0	0.0	0.0	0.0	#DIV/0!	791.3	96.4	49.1	65.9	1.5	1958	0.404	131.7
1984	826.6	96.9	55.3	68.9	1.4	0.0	0.0	0.0	0.0	#DIV/0!	826.6	96.9	55.3	68.9	1.4	2300	0.359	117.1
1985	861.9	106.4	58.5	71.8	1.5	0.0	0.0	0.0	0.0	#DIV/0!	861.9	106.4	58.5	71.8	1.5	2600	0.332	108.0
1986	897.2	116.0	54.7	74.8	1.6	0.0	0.0	0.0	0.0	#DIV/0!	897.2	116.0	54.7	74.8	1.6	2685	0.334	108.9
1987	1042.7	133.8	50.9	86.9	1.5	0.0	0.0	0.0	0.0	#DIV/0!	1042.7	133.8	50.9	86.9	1.5	2778	0.375	122.3

Figure 2-4  
Crystal Clear WSC Historical Water Use and Source

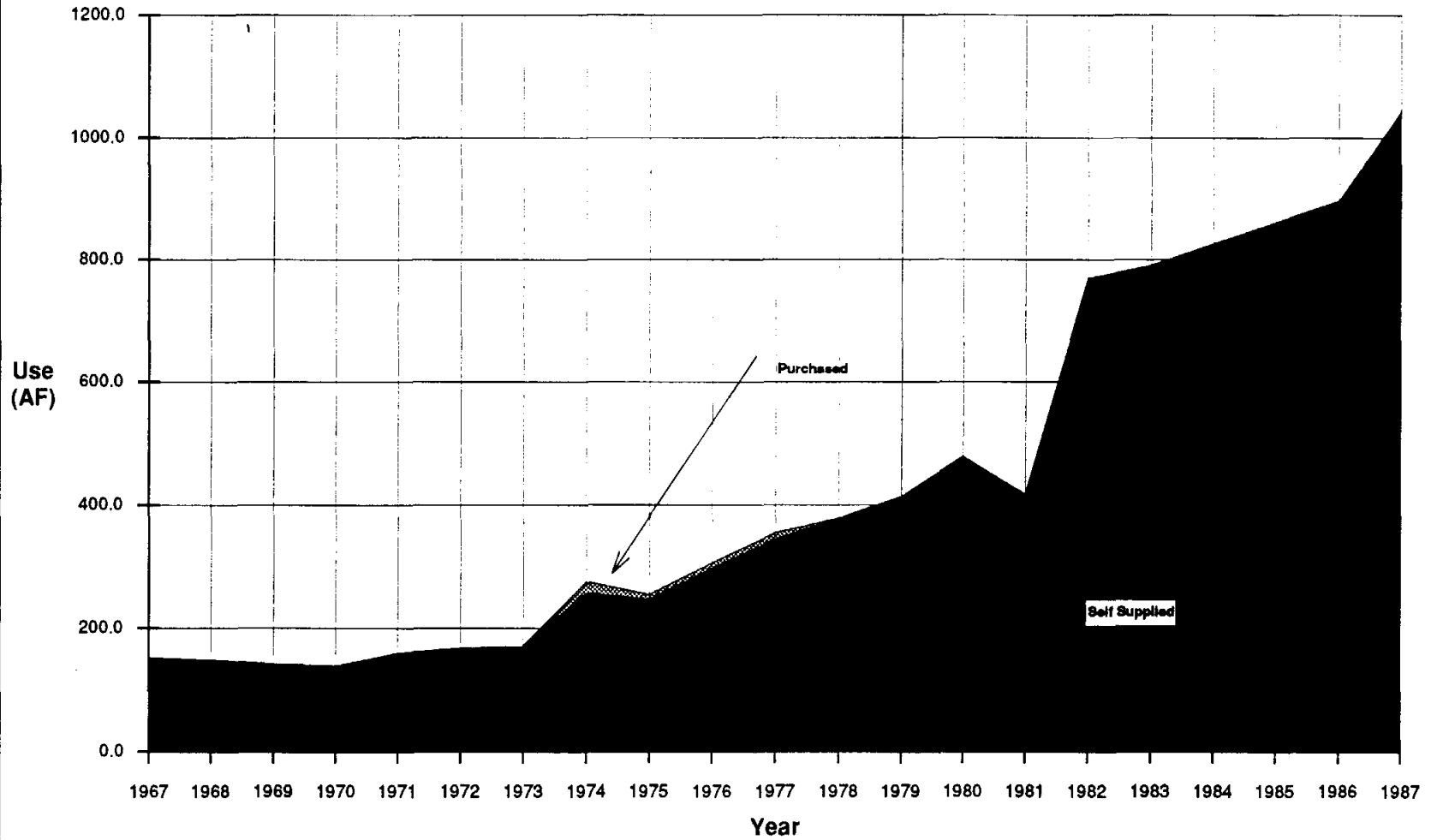

Table 2-5  
East Central Water Supply Corporation Historical Use

Year	January			February			March			April			May			June		
	Self. a/	Purch. b/	Total	Self. a/	Purch. b/	Total	Self. a/	Purch. b/	Total	Self. a/	Purch. b/	Total	Self. a/	Purch. b/	Total	Self. a/	Purch. b/	Total
1977	0.0	32.7	32.7	0.0	31.4	31.4	0.0	27.6	27.6	0.0	35.3	35.3	0.0	33.6	33.6	0.0	36.6	36.6
1978	0.0	24.3	24.3	0.0	23.2	23.2	0.0	24.6	24.6	0.0	26.1	26.1	0.0	29.6	29.6	0.0	33.1	33.1
1979	0.0	35.4	35.4	0.0	40.4	40.4	0.0	28.0	28.0	0.0	30.8	30.8	0.0	30.8	30.8	0.0	43.9	43.9
1980	0.0	44.5	44.5	0.0	46.1	46.1	0.0	41.1	41.1	0.0	51.0	51.0	0.0	49.2	49.2	0.0	55.7	55.7
1981	0.0	42.6	42.6	0.0	42.8	42.8	0.0	50.4	50.4	0.0	51.5	51.5	0.0	49.3	49.3	0.0	53.4	53.4
1982	0.0	59.9	59.9	0.0	58.0	58.0	0.0	45.1	45.1	0.0	54.2	54.2	0.0	66.3	66.3	0.0	58.0	58.0
1983	0.0	47.5	47.5	0.0	44.6	44.6	0.0	52.8	52.8	0.0	66.6	66.6	0.0	82.2	82.2	0.0	67.8	67.8
1983	0.0	77.2	77.2	0.0	52.1	52.1	0.0	64.5	64.5	0.0	84.3	84.3	0.0	119.1	119.1	0.0	60.0	60.0
1985	0.0	62.2	62.2	0.0	77.5	77.5	0.0	79.2	79.2	0.0	64.8	64.8	0.0	74.5	74.5	0.0	92.2	92.2
1986	0.0	69.1	69.1	0.0	65.8	65.8	0.0	58.8	58.8	0.0	91.3	91.3	0.0	108.4	108.4	0.0	82.8	82.8
1987	0.0	97.1	97.1	0.0	63.5	63.5	0.0	73.0	73.0	0.0	84.5	84.5	0.0	93.7	93.7	0.0	91.7	91.7
1988	0.0	72.6	72.6	0.0	74.9	74.9	0.0	79.2	79.2	0.0	76.8	76.8	0.0	112.0	112.0	0.0	134.8	134.8

Year	July			August			September			October			November			December		
	Self. a/	Purch. b/	Total	Self. a/	Purch. b/	Total	Self. a/	Purch. b/	Total	Self. a/	Purch. b/	Total	Self. a/	Purch. b/	Total	Self. a/	Purch. b/	Total
1977	0.0	40.5	40.5	0.0	42.0	42.0	0.0	33.7	33.7	0.0	28.5	28.5	0.0	30.5	30.5	0.0	28.5	28.5
1978	0.0	23.8	23.8	0.0	34.5	34.5	0.0	21.4	21.4	0.0	40.2	40.2	0.0	41.0	41.0	0.0	40.9	40.9
1979	0.0	46.7	46.7	0.0	55.1	55.1	0.0	63.9	63.9	0.0	81.5	81.5	0.0	83.3	83.3	0.0	58.0	58.0
1980	0.0	75.3	75.3	0.0	123.7	123.7	0.0	73.3	73.3	0.0	54.1	54.1	0.0	55.0	55.0	0.0	60.2	60.2
1981	0.0	63.6	63.6	0.0	81.0	81.0	0.0	60.3	60.3	0.0	63.2	63.2	0.0	59.9	59.9	0.0	46.5	46.5
1982	0.0	104.7	104.7	0.0	120.1	120.1	0.0	97.2	97.2	0.0	116.8	116.8	0.0	70.6	70.6	0.0	68.0	68.0
1983	0.0	88.5	88.5	0.0	97.8	97.8	0.0	107.0	107.0	0.0	63.4	63.4	0.0	71.9	71.9	0.0	67.6	67.6
1983	0.0	87.7	87.7	0.0	133.3	133.3	0.0	109.0	109.0	0.0	79.1	79.1	0.0	74.9	74.9	0.0	62.2	62.2
1985	0.0	84.8	84.8	0.0	107.0	107.0	0.0	98.3	98.3	0.0	146.6	146.6	0.0	73.3	73.3	0.0	61.0	61.0
1986	0.0	96.9	96.9	0.0	181.5	181.5	0.0	118.1	118.1	0.0	91.0	91.0	0.0	78.7	78.7	0.0	77.5	77.5
1987	0.0	109.1	109.1	0.0	135.8	135.8	0.0	147.4	147.4	0.0	103.9	103.9	0.0	97.9	97.9	0.0	85.6	85.6
1988	0.0	154.4	154.4	0.0	157.5	157.5	0.0	146.1	146.1	0.0	115.6	115.6	0.0	114.7	114.7	0.0	96.1	96.1

a/ Self-Supplied Ground & Surface  
b/ Purchased from City of San Antonio

	Self-Supplied					Purchased					Total Used					No. Taps	Annual Use	
	Total AF	Max. AF	Min. AF	AF	Max/Avg.	Total AF	Max. AF	Min. AF	Avg. AF	Max/Avg.	Total AF	Max. AF	Min. AF	Avg. AF	Max/Avg.		AF/Tap	gal./Tap
1977	0.0	0.0	0.0	0.0	-	400.9	42.0	27.6	33.4	1.3	400.9	42.0	27.6	33.4	1.3	1399	0.287	93.4
1978	0.0	0.0	0.0	0.0	-	362.7	41.0	21.4	30.2	1.4	362.7	41.0	21.4	30.2	1.4	1600	0.227	73.9
1979	0.0	0.0	0.0	0.0	-	597.8	83.3	28.0	49.8	1.7	597.8	83.3	28.0	49.8	1.7	1702	0.351	114.5
1980	0.0	0.0	0.0	0.0	-	729.2	123.7	41.1	60.8	2.0	729.2	123.7	41.1	60.8	2.0	1812	0.402	131.1
1981	0.0	0.0	0.0	0.0	-	664.5	81.0	42.6	55.4	1.5	664.5	81.0	42.6	55.4	1.5	2020	0.329	107.2
1982	0.0	0.0	0.0	0.0	-	918.9	120.1	45.1	76.6	1.6	918.9	120.1	45.1	76.6	1.6	2111	0.435	141.9
1983	0.0	0.0	0.0	0.0	-	857.7	107.0	44.6	71.5	1.5	857.7	107.0	44.6	71.5	1.5	2189	0.392	127.7
1983	0.0	0.0	0.0	0.0	-	1003.4	133.3	52.1	83.6	1.6	1003.4	133.3	52.1	83.6	1.6	2305	0.435	141.9
1985	0.0	0.0	0.0	0.0	-	1021.4	146.6	61.0	85.1	1.7	1021.4	146.6	61.0	85.1	1.7	2417	0.423	137.7
1986	0.0	0.0	0.0	0.0	-	1119.9	181.5	58.8	93.3	1.9	1119.9	181.5	58.8	93.3	1.9	2500	0.448	146.0
1987	0.0	0.0	0.0	0.0	-	1183.2	157.5	72.6	98.6	1.6	1183.2	157.5	72.6	98.6	1.6	2612	0.453	147.6
1988	0.0	0.0	0.0	0.0	-	1334.7	157.5	157.5	111.2	1.4	1334.7	0.0	0.0	111.2	0.0	2672	0.500	162.8

Figure 2-5  
East Central Water Supply Corporation  
Historical Water Use

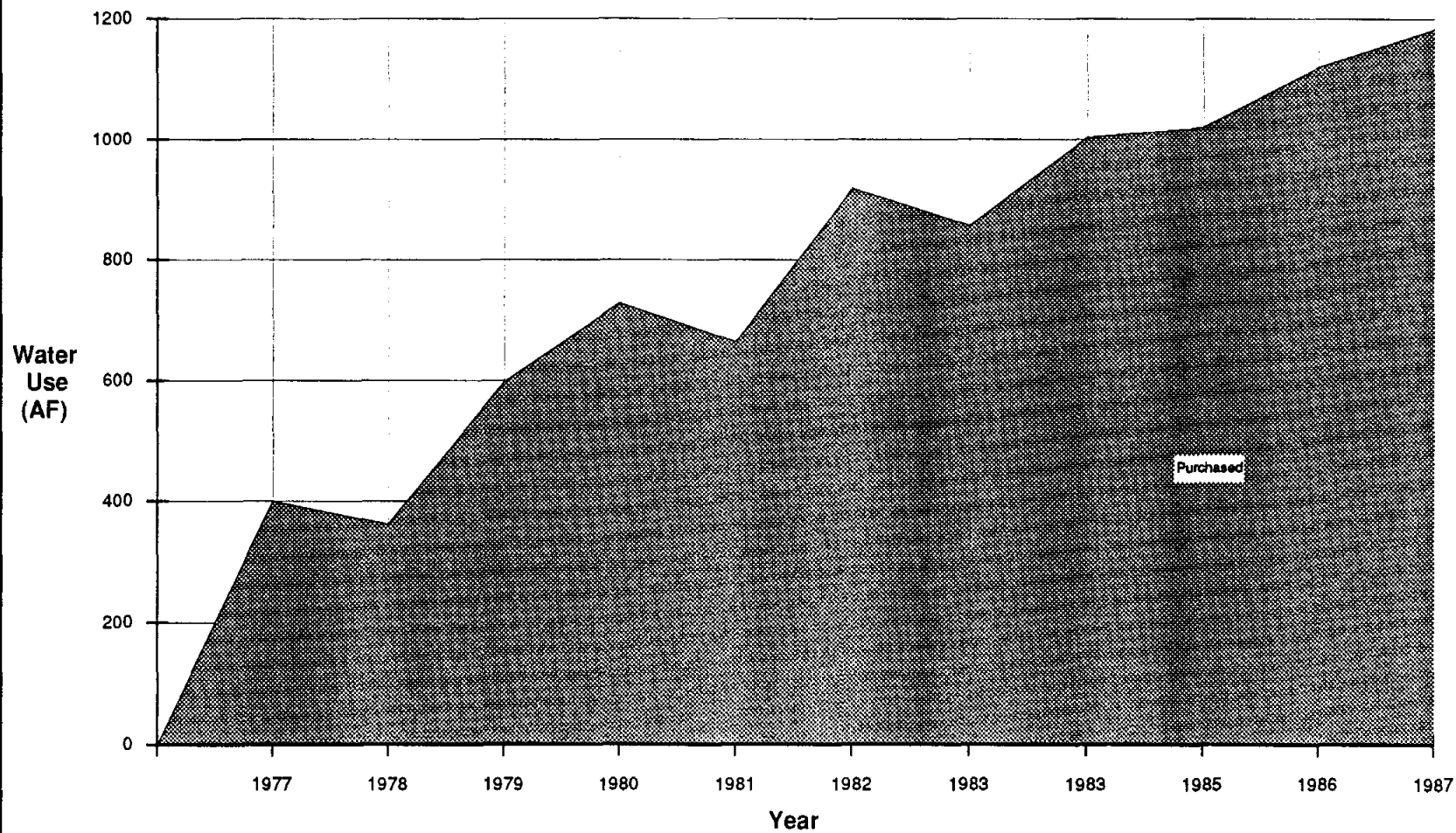



**LEGEND**

- ▨ CRYSTAL CLEAR W S C
- ▩ GREEN VALLEY W S C
- ▧ SPRINGS HILL W S C
- ▦ EAST CENTRAL W S C
- PLANT
- BOOSTER STATION
- △ WELL
- ELEVATED TANK
- STAND PIPE
- ⊕ MASTER METER
- ⊠ WATER TREATMENT PLANT
- 6" WATERLINE (UNLESS NOTED OTHERWISE)
- AREAS WITH WATERLINES LESS THAN 6" DIAMETER

CANYON REGIONAL WATER AUTHORITY

**Figure 2-6**  
**Generalized CRWA Infrastructure**

MICHAEL SULLIVAN AND ASSOCIATES, INC.  
 ABBE / GARRETT ENGINEERING, INC.  
 GEBHARD ENGINEERS, INC.

CANYON REGIONAL WATER SUPPLY STUDY  
EXISTING CONDITIONS

The information used in establishing the service area boundaries for the individual water supply corporations was obtained from the Texas Water Commission (TWC). The inventory of existing production, treatment, and storage capacities was compiled from the most recent sanitary surveys of the water systems, as conducted by the Texas Department of Health (TDH). The locations of major facilities and distribution and transmission lines were provided by the corporations directly or through their district engineers.

### 2.3.2 Green Valley Water Supply Corporation

#### General Description

Green Valley Water Supply Corporation encompasses an area of approximately 160 square miles south and southeast of the City of New Braunfels (Figure 2-7). Green Valley provides service to approximately 11,000 persons through 4,189 connections. The majority of the service area is within Guadalupe County; although, service is provided to portions of Bexar and Comal Counties. Green Valley obtains its water from two groundwater sources and through an interconnect to the City of New Braunfels. Green Valley also provides wholesale water service to the City of Cibolo through an interconnect.

#### Facilities Description

Green Valley WSC owns and operates two well sites located on FM 2252 in Comal County approximately six miles southwest of the City of New Braunfels. The two wells have a combined rated capacity of 3,400 gpm. In addition to the two well sites, Green Valley operates six high service booster stations, with a total rated capacity of 11,500 gpm. Ground storage facilities are located at each of the high service booster stations. Total system ground storage capacity is 1.598 MG. Pressure maintenance is provided through the use of pressure tanks and elevated storage. Total elevated storage in the system is 600,000 gallons with 26,000 gallons of pressure tank capacity provided. A summary of the Green Valley system components is presented in Table 2-6.

The temporary interconnect with the City of New Braunfels is capable of providing a maximum capacity of contractual or physical limit of 1,100 gpm. The interconnect is to provide service to the northeast portion of the Green Valley service area. In addition to receiving water from the City of New Braunfels, Green Valley provides service to the City of Cibolo through an interconnect agreement. Green Valley WSC is committed to providing a total maximum flow rate of 1,320 gpm to Cibolo; however, average daily use to date amounts to only 174 gpm with a recorded peak day consumption of 721 gpm.

According to TDH records, the average daily usage within the system is approximately 1.781 million gallons (gpm). Maximum daily usage is reported to be 1.900 million gallons (gpm). System pressures range from 60 psi to 100 psi.

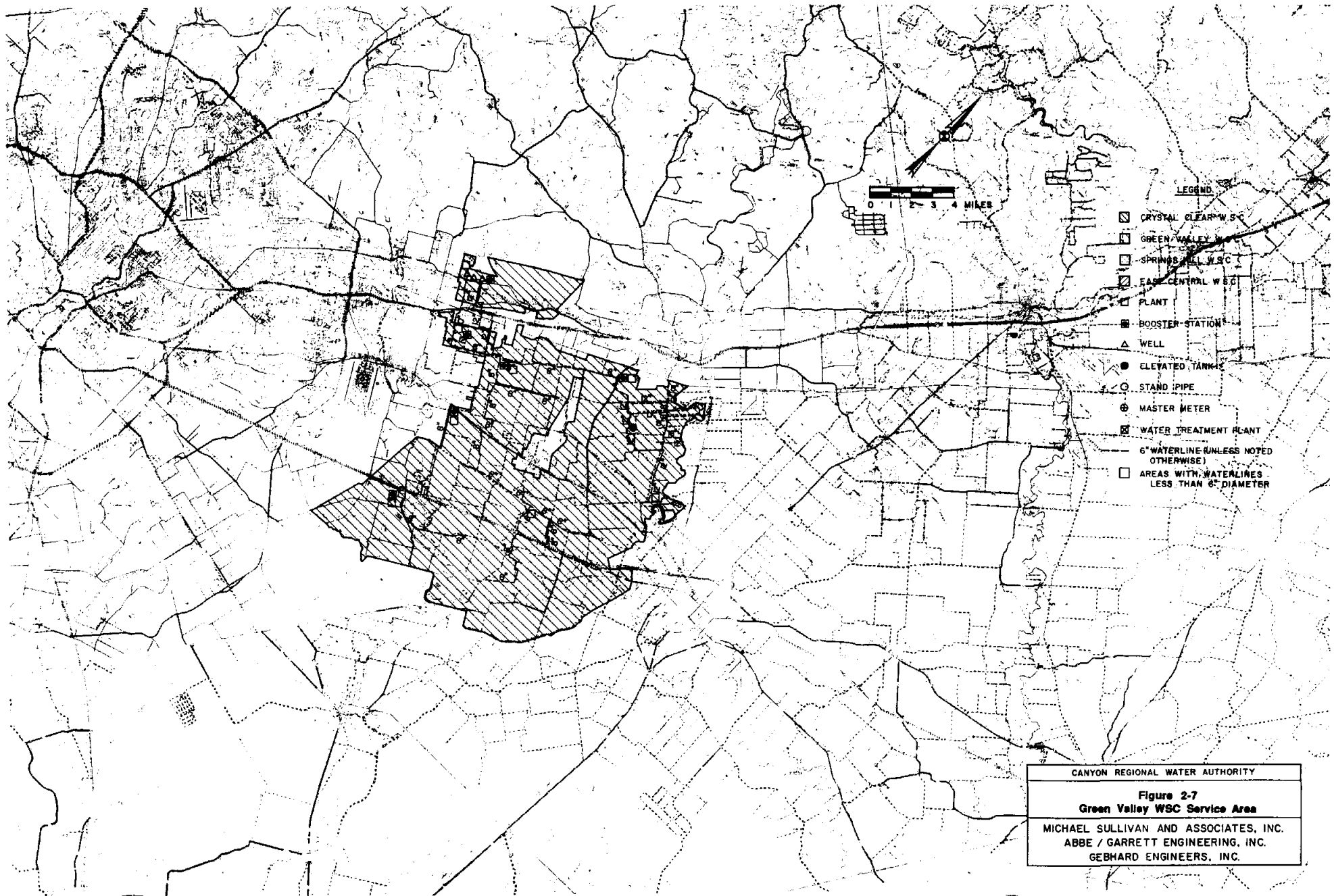

CANYON REGIONAL WATER AUTHORITY

**Figure 2-7**  
**Green Valley WSC Service Area**

MICHAEL SULLIVAN AND ASSOCIATES, INC.  
 ABBE / GARRETT ENGINEERING, INC.  
 GEBHARD ENGINEERS, INC.

**TABLE 2-6  
GREEN VALLEY WATER SUPPLY CORPORATION  
SYSTEM COMPONENT SUMMARY (1)**

**WELL PUMP CAPACITY**

NO.	LOCATION	TYPE	RATED CAPACITY (GPM)	TESTED CAPACITY (GPM)	DEPTH (FT)
WELL #1	FM 2252	VT	1,800	1,600	230
WELL #2	FM 2252	VT	1,600	800	230
TOTAL			3,400	2,400	

**HIGH SERVICE PUMP CAPACITY**

LOCATION	PUMP NUMBER	RATED CAPACITY (GPM)
WELL SITE #1	1	800
	2	800
	3	200
WELL SITE #2	1	800
	2	800
	3	450
	4	450
PUMP STATION #1	1	450
	2	450
	3	450
PUMP STATION #2	1	450
	2	450
	3	450
	4	450
PUMP STATION #3	1	450
	2	450
	3	450
	4	450
PUMP STATION #5	1	250
	2	250
PUMP STATION #6	1	350
	2	350
PUMP STATION #9	1	500
	2	250
	3	250
	4	500
TOTAL		11,900

**STORAGE FACILITIES**

LOCATION	TYPE	CAPACITY (GALLONS)
WELL SITE #1	GROUND	210,000
	PRESSURE TANK	5,000
WELL SITE #2	GROUND	210,000
	PRESSURE TANK	5,000
	GROUND	200,000
	PRESSURE TANK	3,000
	GROUND	127,000
	GROUND	80,000
	GROUND	127,000
	GROUND	80,000
	ELEVATED	100,000
	GROUND	60,000
	GROUND	20,000
	PRESSURE TANK	3,000
	GROUND	200,000
	GROUND	84,000
	PRESSURE TANK	5,000
	GROUND	200,000
ELEVATED	300,000	
PRESSURE TANK	5,000	
ELEVATED	100,000	
ELEVATED	100,000	
TOTAL GROUND STORAGE (GAL.)		1,598,000
TOTAL ELEVATED STORAGE (GAL.)		600,000
TOTAL STORAGE (GAL.)		2,198,000



**TABLE 2-6**  
**GREEN VALLEY WATER SUPPLY CORPORATION**  
**SYSTEM COMPONENT SUMMARY**  
 (continued)

**EVALUATION OF SYSTEM CAPACITIES (MINIMUM REQUIREMENTS)**

ITEM	AMOUNT REQUIRED	AMOUNT PROVIDED	EXCESS	DEFICIT
WELL PUMP CAPACITY (GPM) (2)	2,517	3,400	883	-
PRESSURE TANK (GAL)	4,600	26,000	21,400	-
ELEVATED STORAGE (GAL)	419,000	600,000	181,000	-
TOTAL STORAGE (GAL)	839,000	2,198,000	1,359,000	-
SERVICE PUMPS (GPM)	8,390	11,900	3,510	-

**MISCELLANEOUS DATA**

CONNECTIONS SERVED	4,195
ESTIMATED POPULATION SERVED	11,000
MAXIMUM DAILY USAGE (GALLONS)	1,900,000
AVERAGE DAILY USAGE (GALLONS)	1,781,000
SYSTEM PRESSURE (PSI)	60-100
INTERCONNECTS	CITY OF NEW BRAUNFELS CITY OF CIBOLO
DATE OF LAST SANITARY SURVEY	16-Aug-89

- 
- (1) BASED ON TEXAS DEPARTMENT OF HEALTH SANITARY SURVEY OF SYSTEM  
 (2) WELL PUMP CAPACITY BASED ON RATED PUMP CAPACITY.

### System Evaluation

Based upon the results of the most recent sanitary survey conducted by TDH, dated August 16, 1989, Green Valley meets or exceeds State minimum requirements, for well capacity, pressure storage, elevated storage, total storage, and high service pump capacity. It should be noted, however, that TDH evaluates well pump capacity based on the rated capacity of the pumps and not on the tested capacity. If the values contained in the sanitary survey for tested pump capacity are used to evaluate well pump capacity, Green Valley would be found to be deficient in well pump capacity by 117 gpm. Garcia and Wright Consulting Engineers, Inc. in their report entitled Green Valley Water Supply Corporation, 1989 Facility Evaluation, performed an evaluation of well pumping capabilities and determined that Green Valley WSC is deficient by approximately 393 gpm in well pumping capacity. Although there is some discrepancy in the amount, it is clear that, Green Valley WSC is deficient in well pumping capacity. According to the Garcia and Wright's report, the supply deficits are compensated for by the interconnects with the City of New Braunfels.

### 2.3.3 Springs Hill Water Supply Corporation

#### General Description

Springs Hill Water Supply Corporation serves an area of approximately 177 square miles in rural Guadalupe and Wilson Counties (Figure 2-8). The City of Seguin is virtually surrounded by the Springs Hill WSC service boundary. Springs Hill WSC provides service to an estimated 9,250 persons through 3,088 connections. Springs Hill WSC is the only CRWA member which utilizes a surface water source: the Guadalupe River. The Guadalupe River treatment plant serves the southern, southeast, and southwest portions of the service area. An interconnect with the City of New Braunfels serves the northern portion of the service area. Springs Hill WSC also maintains an interlocal agreement with the City of Seguin whereby both parties provide emergency service to each other's system, as needed.

#### Facilities Description

The Springs Hill WSC water treatment plant (1.51 MGD treatment capacity) is located on the Guadalupe River approximately 0.4 miles west of the intersection of FM 725 and State Highway 46. Water is drawn from the river through three raw water intake pumps with a total rated capacity of 3,000 gpm. The raw water intake pumps discharge to the treatment facility which consists of two up-flow clarifiers, two gravity flow filters, three pressure flow filters, two clearwell reservoirs, and post chlorination facilities. Six high service pumps distribute water from the plant to the water system. The total clearwell capacity at the plant is 793,000 gallons. Springs Hill WSC operates four remote high service booster stations with a total rated pumping capacity of 4,910 gpm. The remote high service pumps take suction from ground storage facilities located at each booster station. Total ground storage capacity available from the booster station is

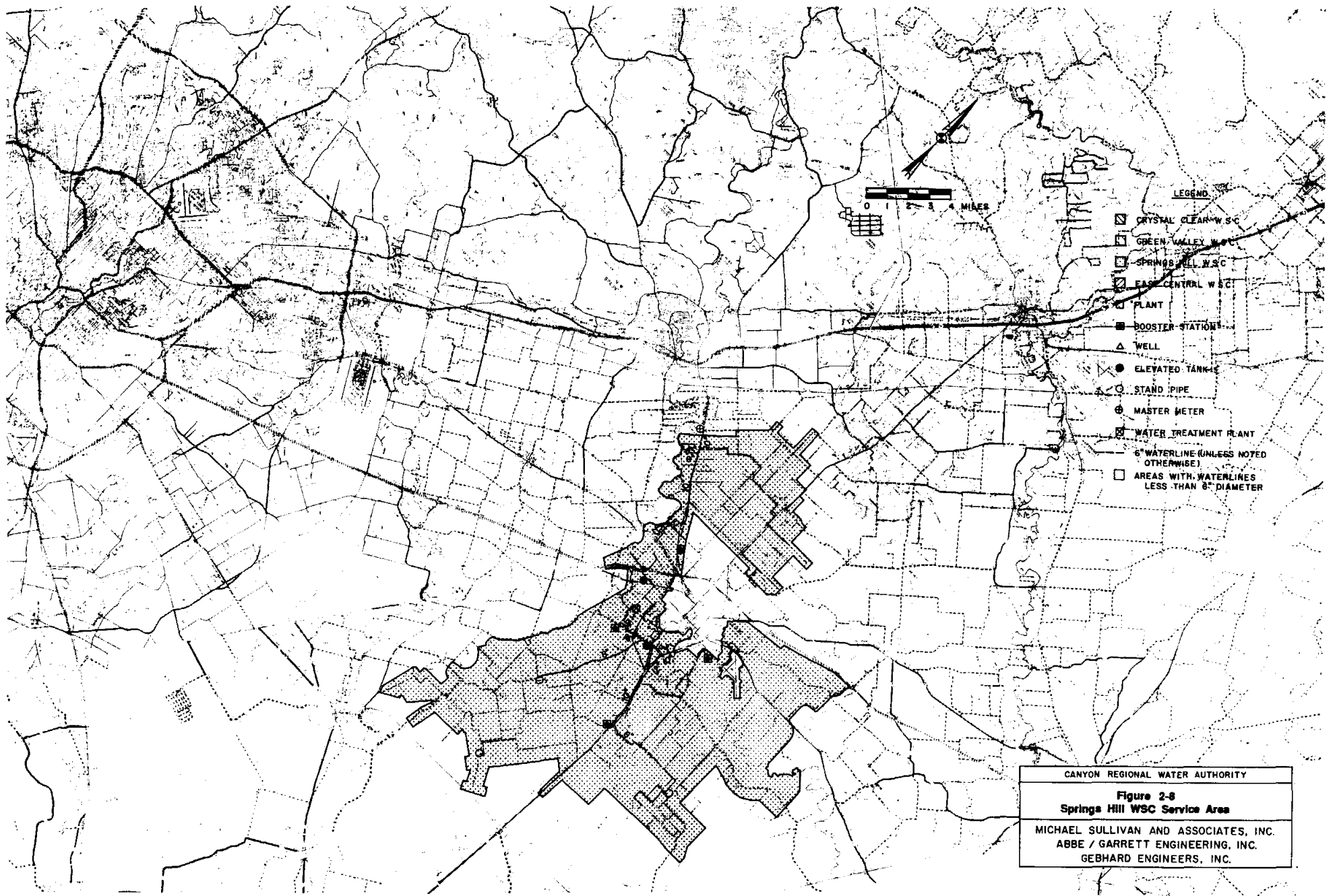

CANYON REGIONAL WATER AUTHORITY

**Figure 2-8**  
**Springs Hill WSC Service Area**

MICHAEL SULLIVAN AND ASSOCIATES, INC.  
 ABBE / GARRETT ENGINEERING, INC.  
 GEBHARD ENGINEERS, INC.

CANYON REGIONAL WATER SUPPLY STUDY  
EXISTING CONDITIONS

241,000 gallons. Elevated tanks, standpipes, and pressure tank facilities are utilized to enhance pressure maintenance within the distribution system. The standpipes provide both elevated and ground storage capacity. The four standpipes provide a total storage capacity of 561,000 gallons of which 200,000 is considered to be elevated. Elevated tank capacity in the system is 275,000 gallons. Total elevated storage capacity (elevated tank volume plus elevated standpipe volume) is 475,000 gallons. Total ground storage volume, including standpipe ground storage capacity is 602,000 gallons. Pressure tank capacity within the system is 26,000 gallons. A summary of the Springs Hill WSC system components is presented in Table 2-7.

Average daily usage within the system, according to TDH records, is approximately 776,000 gallons. The maximum daily usage is reported to be approximately 1,669,000 gallons. System pressures range between 45 psi and 90 psi.

#### System Evaluation

The most recent sanitary survey conducted by TDH, dated September 14, 1988, concludes that Springs Hill meets or exceeds State minimum requirements for pressure storage, elevated storage, total storage, and high service pump capacity. Based upon maximum daily usage, however, the system fails to meet required treatment capacity with a deficit of approximately 158,000 gallons per day.

#### 2.3.4 Crystal Clear Water Supply Corporation

##### General Description

Crystal Clear Water Supply Corporation serves the rural areas of Guadalupe, Comal, and Hays Counties generally bounded by the City's of Seguin, New Braunfels, San Marcos, and Luling (Figure 2-9). Crystal Clear WSC services 8,349 persons through 2,783 connections within its approximately 171 square mile service area. Although a majority of its water is obtained through self-maintained groundwater sources, Crystal Clear also maintains an emergency interconnects with the Springs Hill WSC.

##### Facilities Description

Crystal Clear WSC owns and operates four well sites with a total of seven wells. The total rated well pump capacity of the seven wells is 3,350 gpm. Ground storage is provided at each of the well sites and seven remote high service booster stations. Fifteen ground tanks and one standpipe provide approximately 2,761,800 gallons of ground storage for the system. A portion of the standpipe volume (20%) contributes to the total elevated storage capacity of the system. Crystal Clear WSC utilizes two elevated ground tanks to provide the remainder of its gravity pressure maintenance for the system. Total elevated storage is 504,200 gallons. Nine pressure tanks supplement pressure maintenance in the system and

**TABLE 2-7  
SPRINGS HILL WATER SUPPLY CORPORATION  
SYSTEM COMPONENT SUMMARY (1)**

**RAW WATER PUMP CAPACITY**

NO.	LOCATION	TYPE	RATED CAPACITY (GPM)	TESTED CAPACITY (GPM)
PUMP #1	UADALUPE RIVER PLAN	RAW	800	N/A
PUMP #2	UADALUPE RIVER PLAN	RAW	800	N/A
PUMP #3	UADALUPE RIVER PLAN	RAW	1,400	1,100
<b>TOTAL</b>			<b>2,200</b>	<b>1,100</b>

**HIGH SERVICE PUMP CAPACITY**

LOCATION	PUMP NUMBER	RATED CAPACITY (GPM)
TREATMENT PLANT	1	500
	2	500
	3	500
	1 (STANDBY)	400
	2 (STANDBY)	400
	3 (STANDBY)	400
PLACID HEIGHTS STATION	1	150
	2	150
HIGHWAY 123 STATION	1 (STANDBY)	80
	2 (STANDBY)	80
	3	150
	1 (STANDBY)	75
	2 (STANDBY)	75
HIGHWAY 46 STATION	1	400
	2	400
SAGEBIEL ROAD STATION	1	250
	2	250
<b>TOTAL</b>		<b>4,910</b>
<b>TOTAL TRANSFER PUMP CAPACITY AT TREATMENT PLANT (GPM)</b>		<b>1,925</b>

**STORAGE FACILITIES**

LOCATION	TYPE	CAPACITY (GAL.)
TREATMENT PLANT	CLEARWELL	285,000
	CLEARWELL	508,000
PLACID HEIGHTS STATION	GROUND	10,000
	PRESSURE TANK	2,000
HIGHWAY 46 STATION	GROUND	33,000
	GROUND	33,000
	PRESSURE TANK	2,500
SAGEBIEL ROAD STATION	GROUND	100,000
	PRESSURE TANK	5,000
HICKORY FOREST STATION	STANDPIPE	50,000
	STANDPIPE	350,000
JAKES COLONY	STANDPIPE	133,000
HWY 123 (SPRINGS HILL TANK)	ELEVATED	75,000
HWY 725 (NOB HILL)	ELEVATED	100,000
IH-10 (5 MI.)	ELEVATED	100,000
HIGHWAY 123 STATION	GROUND	65,000
ELM CREEK	STANDPIPE	28,000
TREATMENT PLANT	CLARIFIER	500,000
	CLARIFIER	225,000
<b>TOTAL CLEARWELLS (GAL.)</b>		<b>793,000</b>
<b>TOTAL GROUND STORAGE (GAL.)</b>		<b>475,000</b>
<b>TOTAL ELEVATED STORAGE (GAL.)</b>		<b>602,000 (361,000 IN STANDPIPES)</b>
<b>TOTAL PRESSURE TANK (GAL.)</b>		<b>9,500 (200,000 IN STANDPIPES)</b>
<b>TOTAL CLARIFIERS (GAL.)</b>		<b>725,000</b>
<b>TOTAL STORAGE WITH CLARIFIERS (GAL.)</b>		<b>2,595,000</b>
<b>TOTAL STORAGE WITHOUT CLARIFIERS (GAL.)</b>		<b>1,870,000</b>

**TABLE 2-7**  
**SPRINGS HILL WATER SUPPLY CORPORATION**  
**SYSTEM COMPONENT SUMMARY**  
 (continued)

**EVALUATION OF SYSTEM CAPACITIES (MINIMUM REQUIREMENTS)**

ITEM	AMOUNT		EXCESS	DEFICIT
	REQUIRED	PROVIDED		
RAW WATER PUMPS (GPM)	1,853	3,000	1,147	-
CLEARWELL (GAL.)	750,000	793,000	43,000	-
ELEVATED STORAGE (GAL.)	309,000	475,000	166,000	-
TOTAL STORAGE (GAL.)	618,000	1,870,000	1,252,000	-
SERVICE PUMPS (GPM) (3)	6,178	4,910	-	1,268

**MISCELLANEOUS DATA**

CONNECTIONS SERVED	3,088
ESTIMATED POPULATION SERVED	9,265
EXISTING TREATMENT CAPACITY (GPM)	1,510,000
MAXIMUM DAILY USAGE (GAL.) (2)	1,668,000
AVERAGE DAILY USAGE (GAL.)	776,000
SYSTEM PRESSURE (PSI)	45-90
INTERCONNECTS	CITY OF NEW BRAUNFELS CITY OF SEGUIN
DATE OF LAST SANITARY SURVEY	14-Sep-88

(1) BASED ON TEXAS DEPARTMENT OF HEALTH SANITARY SURVEY OF SYSTEM.

(2) SYSTEM ABLE TO MEET MAXIMUM DAILY USE DEMAND.

(3) MAXIMUM DAILY USAGE EXCEEDS EXISTING TREATMENT CAPACITY.

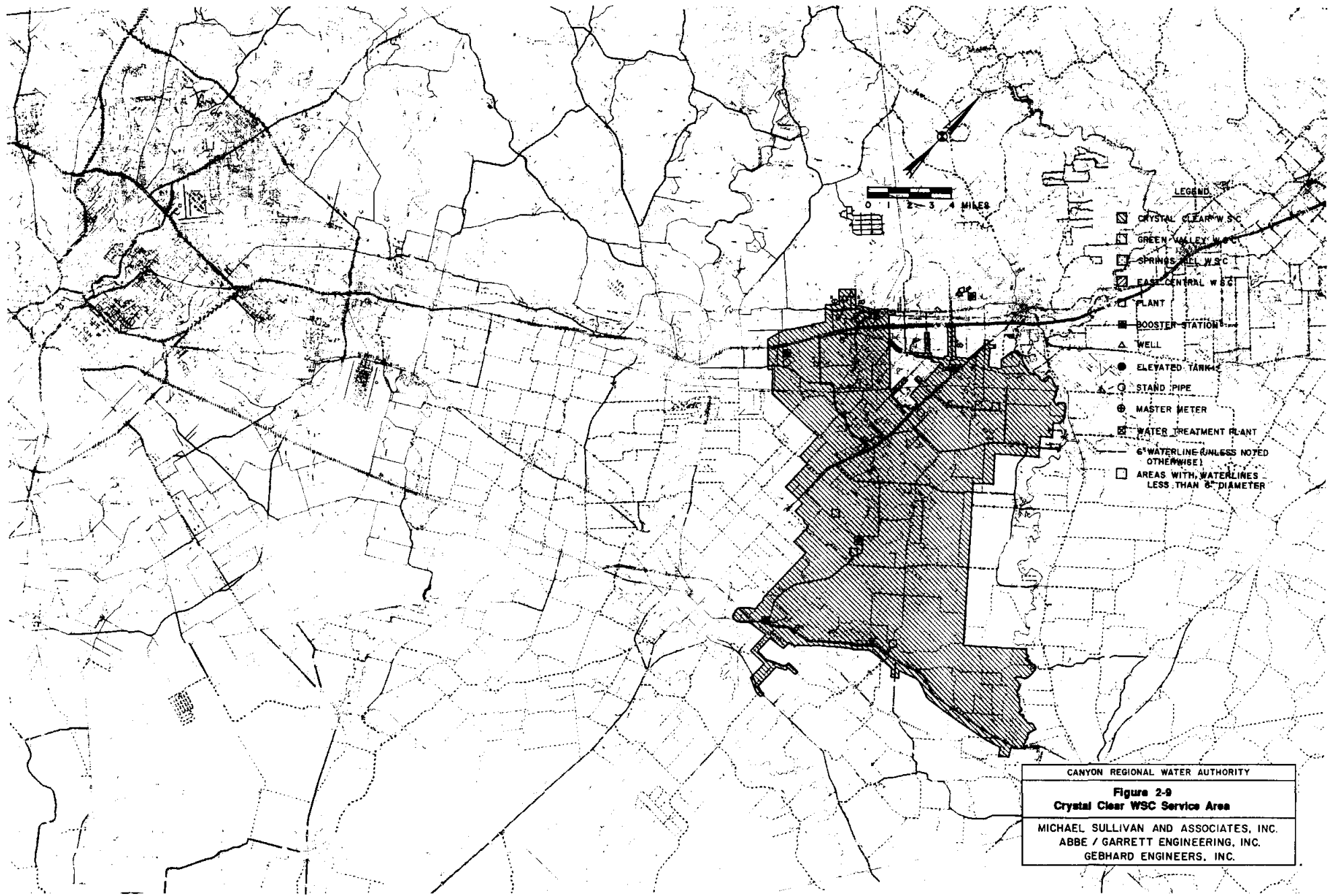

CANYON REGIONAL WATER SUPPLY STUDY  
EXISTING CONDITIONS

provide 44,000 gallons of capacity. A summary of the Crystal Clear WSC system components is presented in Table 2-8.

The average daily water usage is 1,003,000 gallons. Maximum daily use values were not available in the most recent sanitary survey of the system. System pressures range from 50 psi to 110 psi.

System Evaluation

The most recent sanitary survey conducted by TDH for the system, dated March 29, 1989, concludes that the Crystal Clear system meets or exceeds State minimum requirements for well pump capacity, pressure storage, elevated storage, total storage, and high service pump capacity.

2.3.5 East Central Water Supply Corporation

General Description

East Central Water Supply Corporation provides service to approximately 110 square miles in portions of rural Bexar, Guadalupe, and Wilson Counties (Figure 2-10). Service is provided to 7,998 persons through 2,666 connections. East Central WSC obtains its total water supply from the San Antonio City Water Board via an interconnect agreement. East Central is the only member of the CRWA which does not have water production facilities of its own.

Facilities Description

Water is supplied to East Central WSC from the San Antonio City Water Board through 12-inch connections at the Foster Road Plant and the Old Highway 87 South Plant. Ground storage is provided at the interconnects locations and at two remote high service booster stations. Total ground storage in the system amounts to 561,000 gallons. This amount includes a 46,000 gallon tank located at the Foster Road Plant which is not currently in use. The total high service pump capacity for the system is 2,820 gpm. The high service pumps are the only means by which East Central can maintain pressure in its distribution system, since no pressure tank or elevated tank facilities are in place. The high service pumps run continuously in order to maintain system pressure. A summary of East Central system components is presented in Table 2-9.

The Texas Department of Health reports that the average daily use for the East Central system is approximately 1,187,000 gallons. Maximum daily use figures are not available. System pressures range between 35 psi and 80 psi.



**TABLE 2-8  
CRYSTAL CLEAR WATER SUPPLY CORPORATION  
SYSTEM COMPONENT SUMMARY (1)**

**WELL PUMP CAPACITY**

NO.	LOCATION	TYPE	RATED CAPACITY (GPM)	TESTED CAPACITY (GPM)
WELL #1	UREL ESTATES (STANDE	SUB	200	N/A
WELL #2	MCCARTLE LANE	VT	600	505
WELL #3	MCCARTLE LANE	VT	450	400
WELL #4	HUNTER PLANT	SUB	650	610
WELL #5	NELSON PLANT	SUB	600	350
WELL #6	WILLOW CREEK	SUB	800	N/A
WELL #7	KINGSBURY (STANDBY)	SUB	50	50
<b>TOTAL</b>			<b>3,350</b>	<b>1,915</b>

**HIGH SERVICE PUMP CAPACITY**

LOCATION	PUMP NUMBER	RATED CAPACITY (GPM)
REDWOOD PLANT	1	100
	2	100
	3	500
	4	500
WILLOW CREEK PLANT	1	330
	2	330
NELSON PLANT	1	250
	2	250
ILKA PLANT	1	100
	2	100
	3	690
	4	690
KINGSBURY PLANT	1	150
	2	150
EL CAMINO PLANT	1	350
	2	350
LAUREL ESTATES PLANT	1	200
	2	100
PAPE PLANT	1	160
	2	160
MILL CREEK PLANT	1	150
	2	150
HUNTER PLANT	1	200
	2	350
	3	400
KENSLEER PLANT	1	400
	2	400
<b>TOTAL</b>		<b>7,610</b>

**TABLE 2-8**  
**CRYSTAL CLEAR WATER SUPPLY CORPORATION**  
**SYSTEM COMPONENT SUMMARY**  
(continued)

**STORAGE FACILITIES**

LOCATION	TYPE	CAPACITY (GAL.)
REDWOOD PLANT	GROUND	200,000
	GROUND	20,000
	PRESSURE TANK	5,000
	PRESSURE TANK	1,000
LAUREL ESTATES PLANT	GROUND	20,000
WILLOW CREEK PLANT	GROUND	200,000
	PRESSURE TANK	10,000
HUNTER PLANT	GROUND	30,000
NELSON PLANT	GROUND	200,000
	PRESSURE TANK	10,000
KENSLEER PLANT	GROUND	40,000
	GROUND	200,000
PAPE PLANT	PRESSURE TANK	2,500
	GROUND	300,000
ILKA PLANT	GROUND	200,000
	GROUND	500,000
KINGSBURY PLANT	GROUND	30,000
	PRESSURE TANK	10,000
	PRESSURE TANK	1,500
BOEDER PLANT	GROUND	20,000
	PRESSURE TANK	2,000
MILL CREEK PLANT	ELEVATED GROUND	100,000
	ELEVATED GROUND	340,000
ZORN	GROUND	45,000
	PRESSURE TANK	2,000
EL CAMINO PLANT	STANDPIPE	321,000
TOTAL GROUND STORAGE (GAL.)	2,761,800	
TOTAL PRESSURE TANK (GAL.)	44,000	
TOTAL ELEVATED STORAGE (GAL.)	504,000	
TOTAL STANDPIPE STORAGE (GAL.)	321,000	
TOTAL STORAGE (GAL.)	3,266,000	

**EVALUATION OF SYSTEM CAPACITIES (MINIMUM REQUIREMENTS)**

ITEM	AMOUNT REQUIRED	AMOUNT PROVIDED	EXCESS	DEFICIT
WELL PUMP CAPACITY (GPM)	1,669	3,350	1,681	-
ELEVATED STORAGE (GAL.)	280,000	504,000	224,000	-
TOTAL STORAGE (GAL.)	567,000	3,266,000	2,699,000	-
SERVICE PUMPS (GPM)	5,566	7,610	2,044	-

**MISCELLANEOUS DATA**

CONNECTIONS SERVED	2,783
ESTIMATED POPULATION SERVED	8,350
MAXIMUM DAILY USAGE (GAL.)	N/A
AVERAGE DAILY USAGE (GAL.)	1,003,000
SYSTEM PRESSURE (PSI)	50-110
INTERCONNECTS	SPRINGS HILL WSC
DATE OF MOST RECENT SANITARY SURVEY	29-Mar-89

(1) BASED ON TEXAS DEPARTMENT OF HEALTH SANITARY SURVEY OF SYSTEM.

(2) 20% OF STANDPIPE VOLUME COUNTED AS ELEVATED STORAGE.  
80% OF STANDPIPE VOLUME COUNTED AS GROUND STORAGE.

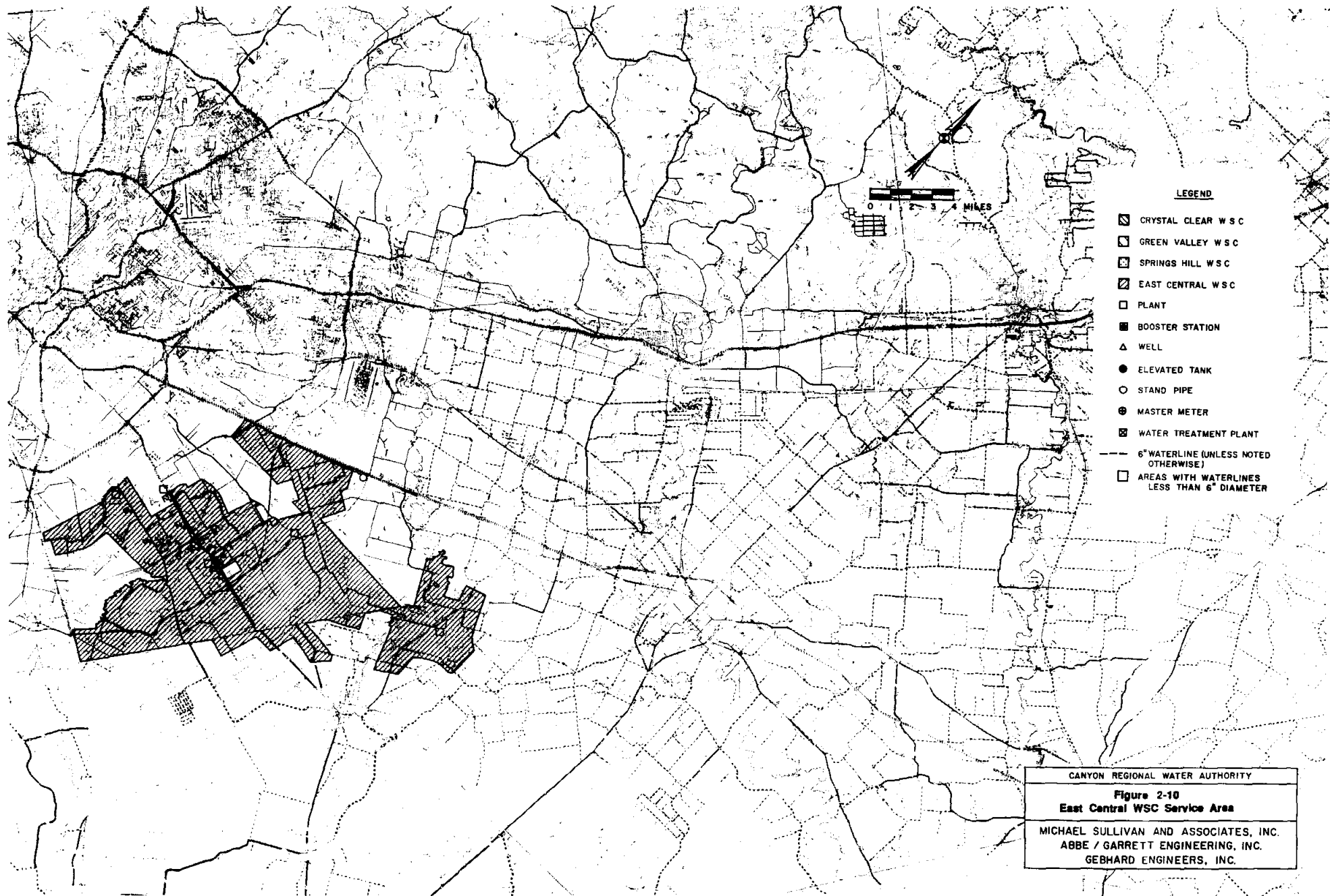

**LEGEND**

- ☐ CRYSTAL CLEAR W S C
- ☐ GREEN VALLEY W S C
- ☐ SPRINGS HILL W S C
- ☐ EAST CENTRAL W S C
- ☐ PLANT
- BOOSTER STATION
- ▲ WELL
- ELEVATED TANK
- STAND PIPE
- ⊙ MASTER METER
- ☒ WATER TREATMENT PLANT
- 6" WATERLINE (UNLESS NOTED OTHERWISE)
- - - AREAS WITH WATERLINES LESS THAN 6" DIAMETER

CANYON REGIONAL WATER AUTHORITY  
**Figure 2-10**  
**East Central WSC Service Area**  
 MICHAEL SULLIVAN AND ASSOCIATES, INC.  
 ABBE / GARRETT ENGINEERING, INC.  
 GEBHARD ENGINEERS, INC.

**TABLE 2-9  
EAST CENTRAL WATER SUPPLY CORPORATION  
SYSTEM COMPONENT SUMMARY (1)**

**WELL/RAW WATER PUMP CAPACITY**

EAST CENTRAL WATER SUPPLY CORPORATION DOES NOT MAINTAIN GROUNDWATER OR SURFACE WATER FACILITIES.

**HIGH SERVICE PUMP CAPACITY**

LOCATION	PUMP NUMBER	RATED CAPACITY (GPM)
PLANT #2	1	400
	2	400
	3	400
PLANT #3	1	250
	2	250
	3	350
	4	350
PLANT #4	1	60
	2	60
	3	150
	4	150
<b>TOTAL</b>		<b>2,820</b>

**STORAGE FACILITIES**

LOCATION	TYPE	CAPACITY (GAL.)
PLANT #1 (NOT IN USE)/ FOSTER RD.	GROUND	46,000
PLANT #2 /OLD HWY. 87 SO.	GROUND	100,000
PLANT #2	GROUND	100,000
PLANT #3 /FM1518@FM 1346	GROUND	120,000
PLANT #3	GROUND	120,000
PLANT #4/HWY 87@KIRKNER RD.	GROUND	75,000
<b>TOTAL</b>		<b>561,000</b>
TOTAL GROUND STORAGE (GAL.)	561,000	
TOTAL STORAGE (GAL.)	561,000	

**EVALUATION OF SYSTEM CAPACITIES (MINIMUM REQUIREMENTS)**

ITEM	AMOUNT REQUIRED	AMOUNT PROVIDED	EXCESS	DEFICIT
WELL OUMP CAPACITY (GPM)	N/A	N/A	-	-
ELEVATED STORAGE (GAL.)	27,000	0	-	27,000
TOTAL STORAGE (GAL.)	530,000	561,000	31,000	-
SERVICE PUMPS (GPM) (2)	5,332	2,820	-	2,512

**MISCELLANEOUS DATA**

CONNECTIONS SERVED	2,666
ESTIMATED POPULATION SERVED	8,000
MAXIMUM DAILY USAGE (GAL.)	N/A
AVERAGE DAILY USAGE (GAL.)	1,187,000
SYSTEM PRESSURE (PSI)	35-80
INTERCONNECTS	SAN ANTONIO CITY WATER BOARD
DATE OF MOST RECENT SANITARY SURVEY	22-Dec-88

(1) BASED ON TEXAS DEPARTMENT OF HEALTH SANITARY SURVEY OF SYSTEM.  
(2) ABLE TO MEET SYSTEM PUMPING DEMANDS, BASED ON AVERAGE DAILY USAGE.

System Evaluation

The most recent sanitary survey of the system was performed on December 22, 1988. Due to its lack of water production facilities, only East Central is required to meet minimum requirements for elevated storage, total storage, and high service pump capacity. Of these three items, East Central meets only the total storage requirement. East Central is deficient in elevated storage by 27,000 gallons and based upon the number of connections served, it is deficient in high service pumping capacity by 2,512 gpm; however, existing pumping capacity exceeds the daily pump requirement by approximately 1,996 gpm.

### **3.0 POPULATION AND WATER DEMAND PROJECTIONS**

#### **3.1 Population Projections**

The TWDB produces future population estimates for all portions of the State of Texas to be use in water supply and wastewater disposal planning projects. Under the terms of the TWDB/CRWA Planning Grant Contract, the CRWA is to utilize TWDB population estimates in their planning process unless compelling reasons for using alternative estimates are presented. In this study, TWDB future population estimation methodologies are employed. However, it was necessary to modify TWDB estimates to fit the irregular service area boundaries of the CRWA Planning Area. TWDB future population estimates are computed and presented within the context of political boundaries, i.e., counties, cities, and rural areas (including municipalities with populations less than 1,000). The CRWA Service Area encompasses most of Guadalupe County, the northeast corner of Bexar County and smaller portions of Hays, Comal and Wilson Counties. Therefore, ready-made population estimates for the CRWA member WSC service areas were not available.

##### **3.1.1 Projection Methodology**

Most of the CRWA member WSCs have experienced similar rapid population growth rates in the last decade. In addition, all four WSCs share the communality of the same rural settings, population distributions and land use patterns. While there are some basic differences between WSCs, with the exception of persons per connection (in the case of the GVWSC) and per capita use rates (varying from 120 to 160 gcd), the differences are minor. Therefore the following methodology was used to predict future populations, at five-year intervals, for each of the CRWA member WSCs.

The TWDB uses a Cohort Component Method with a Net Migration Component to predict future populations. Simply put, the TWDB uses U.S. Census Bureau derived local rates of fertility and mortality to determine a rate for the naturally expanding population base. In addition, estimates of immigration into the area and emigration from the area are use to estimate a net migration. The TWDB then constructs two models from these data. One model is calibrated to the 1950-70 statistical period which exhibited a much slower rate of Texas population growth than was observed in the late 1970s and early 1980s. Future population estimates using this model represent a conservative or "Low Population Series." A second model is constructed using growth rates developed for the 1970-80 statistical period. Future population estimates using this model represent an optimistic or "High Population Series." For this study, a similar methodology was used to predict future populations for each CRWA member WSC.

The annual rates of population increase for rural Guadalupe County estimated by the TWDB were computed for their High and Low Population Series. TDWR Historical Use Data and TDH Sanitary Surveys yielded the number of connections and the number of persons per connection for each WSC. TWDB

rural Guadalupe County growth rates were applied to the historical water connection data to obtain future High and Low Series numbers of water taps for each WSC. Then using the persons per tap data, future High and Low Series population Estimates were developed for each WSC.

#### Low Series Population Estimates

Low Series population estimates for each of the CRWA member WSCs through the year 2020 are shown in Table 3-1 and Figure 3-1. The GVWSC population is predicted to increase to more than 17,000 people (an 83% increase over the current population); the SHWSC population is predicted to increase to nearly 17,000 people; the CCWSC population is predicted to increase to more than 16,000 people; and the ECWSC population is predicted to increase to more than 15,000 people. The aggregate population of the CRWA Service Area through 2030 is shown in Figure 3-2.

#### High Series Population Estimates

High Series population estimates for each of the CRWA member WSC through the year 2020 are shown in Table 3-1 and Figure 3-3. The GVWSC population is predicted to increase to more than 20,000 people; the SHWSC population is predicted to increase to more than 19,000 people; the CCWSC population is predicted to increase to more than 19,000 people; and the ECWSC population is predicted to increase to nearly 18,000 people. The aggregate population of the CRWA Service Area through 2030 is shown in Figure 3-4.

### 3.1.2 Population Projection Results

All of the CRWA member WSCs continue to demonstrate the rapid rate of future population growth started in the late 1970s and continuing into the 80s. While other areas of Texas have shown a severe growth rate reduction, this trend is not demonstrated in the historical water use data of these four WSCs. Therefore, High Series population estimates most adequately reflect the vigorous growth of the CRWA Planning Area.

## 3.2 Water Demand Projections

### 3.2.1 Water Demand Projection Methodology

The TWDB applies historical per capita water use factors to its High and Low Series future population estimates to determine future water demands. In addition, the TWDB applies water conservation reduction factors to each historical use rate to obtain future demands with and without implementation of water conservation measures. Thus, there are eight possible combinations of future water demand estimates from which to choose.

**Table 3-1**  
**Estimated Populations of CRWA Members WSC Service Area**  
**(1980-2020)**

Year	Green Valley		Springs Hill		Crystal Clear		East Central	
	Low Series	High Series	Low Series	High Series	Low Series	High Series	Low Series	High Series
1980	5,549	5,549	5,032	5,032	4,437	4,437	5,436	5,436
1985	8,258	8,258	8,073	8,073	7,800	7,800	7,251	7,251
1990	9,471	9,803	9,259	9,583	8,946	9,259	8,316	8,608
1995	10,985	11,874	10,738	11,607	10,375	11,215	9,645	10,426
2000	12,497	13,943	12,217	13,631	11,804	13,170	10,973	12,243
2005	13,942	15,975	13,629	15,617	13,169	15,089	12,242	14,027
2010	15,387	18,005	15,042	17,602	14,533	17,006	13,510	15,809
2015	16,368	19,170	16,001	18,740	15,460	18,107	14,372	16,832
2020	17,350	20,336	16,961	19,880	16,388	19,208	15,234	17,856



Figure 3-1  
Projected CRWA Member Future Populations  
Low Series

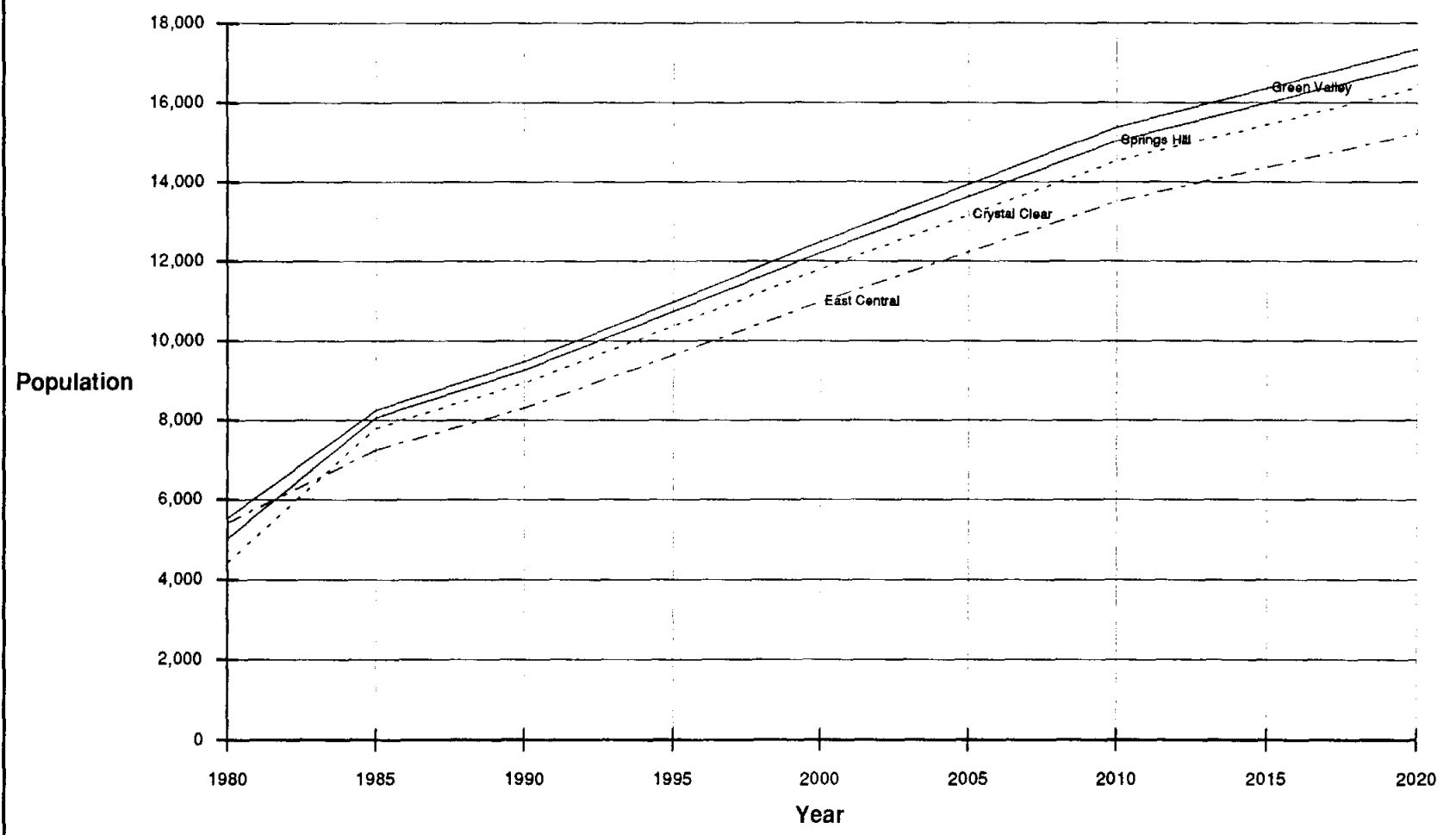

Figure 3-2  
Projected CRWA Member Future Populations  
Low Series

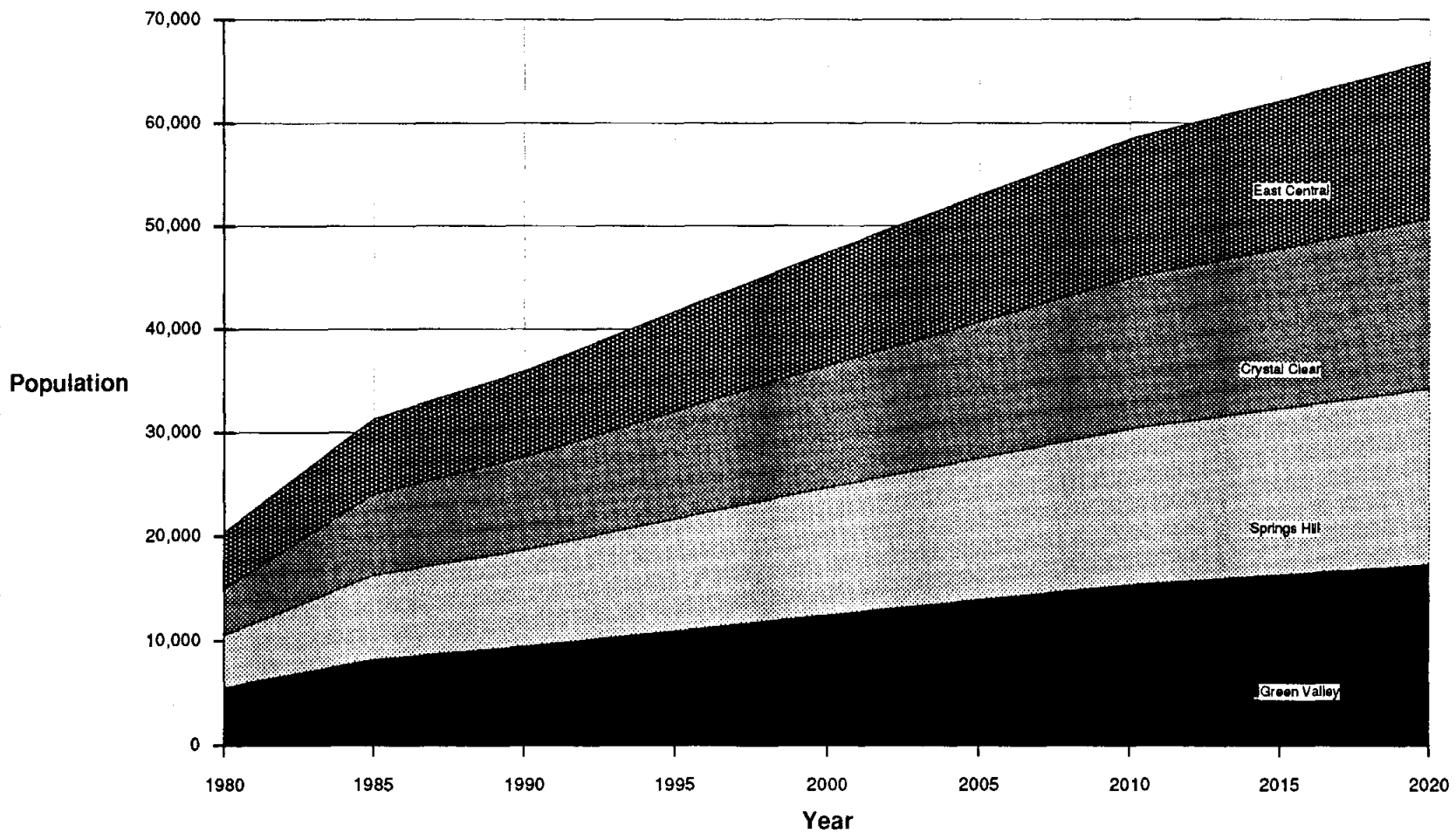

Figure 3-3  
Projected CRWA Member Future Populations  
High Series

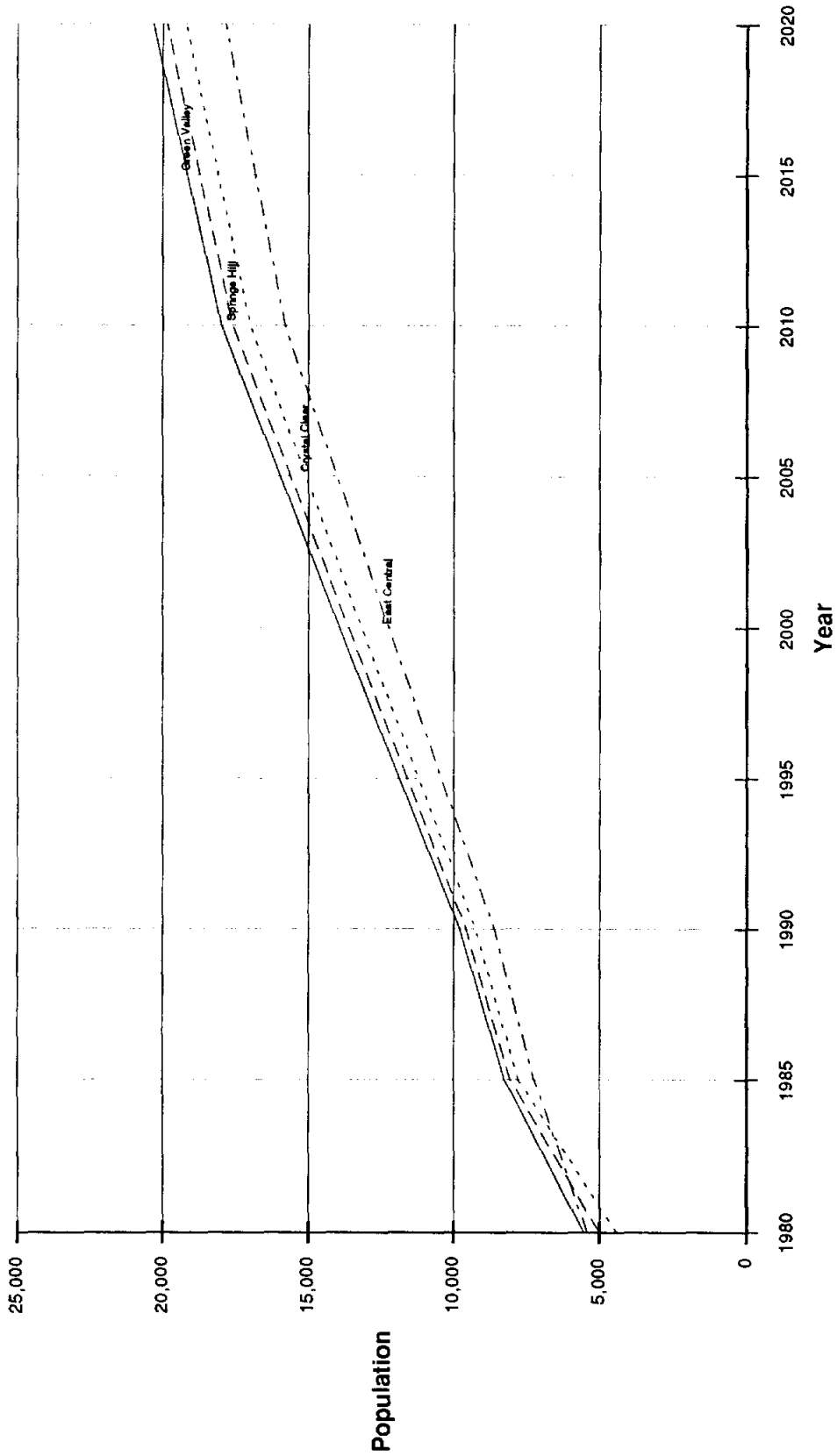
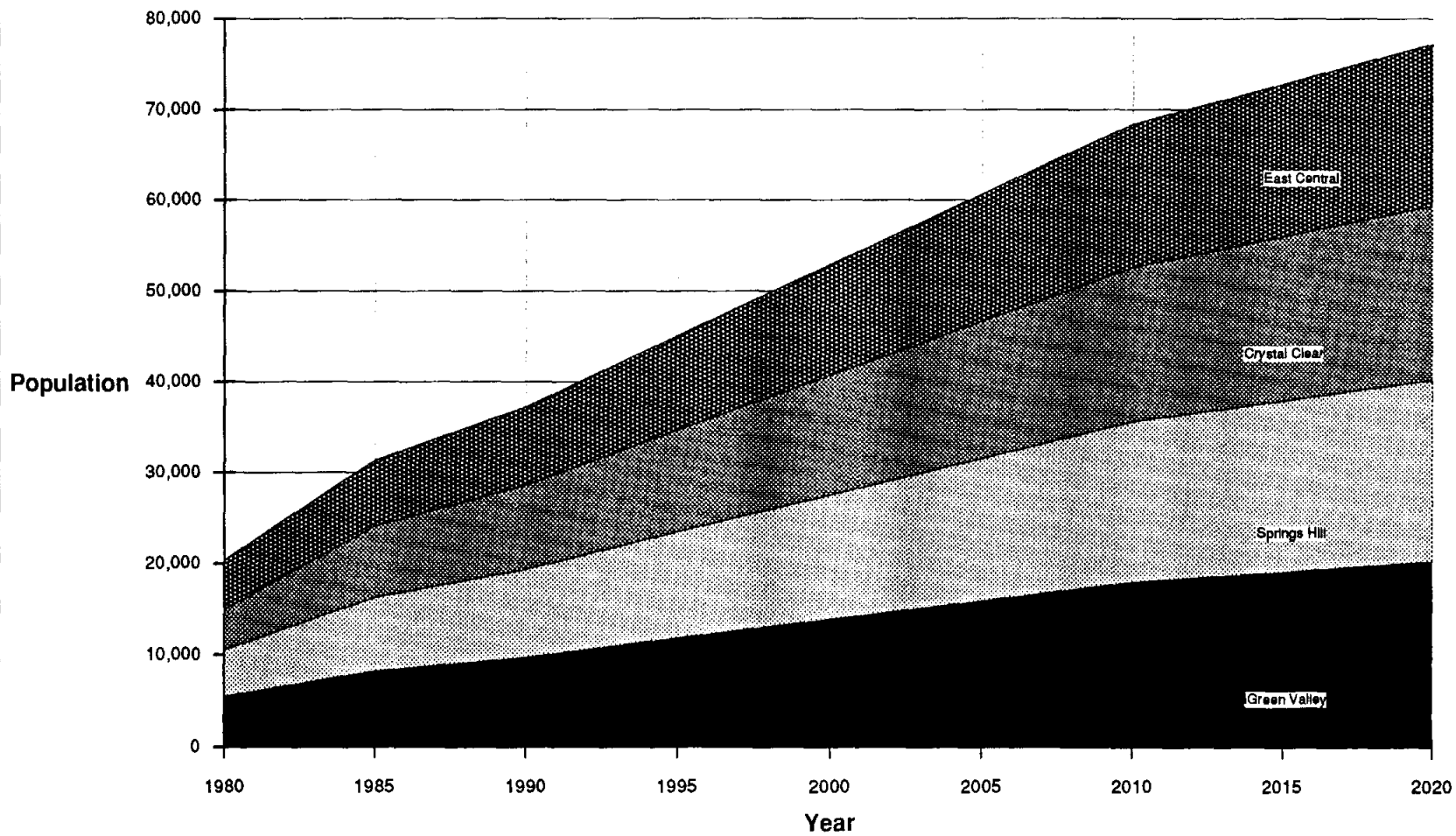

Figure 3-4  
Projected CRWA Member Future Populations  
High Series



CANYON REGIONAL WATER SUPPLY STUDY  
POPULATION AND WATER DEMAND PROJECTIONS

**Low Population Series**

**Average Per Capita Water Use**

**With Water Conservation  
Without Water Conservation**

**High Per Capita Water Use**

**With Water Conservation  
Without Water Conservation**

**High Population Series**

**Average Per Capita Water Use**

**With Water Conservation  
Without Water Conservation**

**High Per Capita Water Use**

**With Water Conservation  
Without Water Conservation**

Average and High Per Capita Water Use Rates are both predicated on the previous ten years of TWDB water use data specific to the county or city. The Average Per Capita Use Rate is simply the average water use rate exhibited over the last decade while the High Per Capita Use Rate is the highest single annual use rate recorded during the last decade.

Savings in water use resulting from implementation of rigorous water conservation programs are also computed by the TWDB. Conservation savings are computed differently for urban and rural settings; however, both are non-linear functions which assume an increasing rate of savings until some ultimate reduction limit is achieved. From that point, annual water conservation savings are assumed constant. For rural areas, the TWDB water conservation savings begin at 2% for the first year and increases to a maximum of 15% in 2020. Thence, conservation savings remain constant at 15%.

**3.2.2 Water Demand Projection Results**

Future water demand projections for each of the WSCs are shown in Table 3-2 and Figures 3-5 through 3-12. These numbers will be valuable in the future treatment capacity and distribution infrastructure design phase of this study. Aggregate CRWA future water demand projections are shown in Figures 3-13 through 3-20 and summarized in Figure 3-21. Depending on the population series, per capita use rate and water conservation scenario chosen, the total CRWA 2020 water demand ranges from 8,000 to 13,500 acre-feet.

**Table 3-2**  
**Estimated Total CRWA Water Demand**  
**(1980-2020)**

Year	Demand (AF)							
	Average Per Capita Water Use				High Per Capita Water Use			
	Low Population Series		High Population Series		Low Population Series		High Population Series	
	Without Conservation	With Conservation	Without Conservation	With Conservation	Without Conservation	With Conservation	Without Conservation	With Conservation
1980	3,000	3,000	3,000	3,000	3,000	3,000	3,000	3,000
1985	4,576	4,576	4,576	4,576	4,576	4,576	4,576	4,576
1990	5,248	5,117	5,432	5,296	6,249	6,093	6,468	6,307
1995	6,087	5,783	6,579	6,250	7,248	6,886	7,835	7,443
2000	6,925	6,406	7,726	7,147	8,246	7,628	9,200	8,510
2005	7,726	6,953	8,852	7,967	9,199	8,279	10,541	9,487
2010	8,526	7,460	9,977	8,730	10,152	8,883	11,880	10,395
2015	9,070	7,827	10,623	9,167	10,800	9,321	12,649	10,916
2020	9,614	8,172	11,268	9,578	11,448	9,731	13,418	11,405

Figure 3-5  
Green Valley WSC Future Demands  
Low Population Series

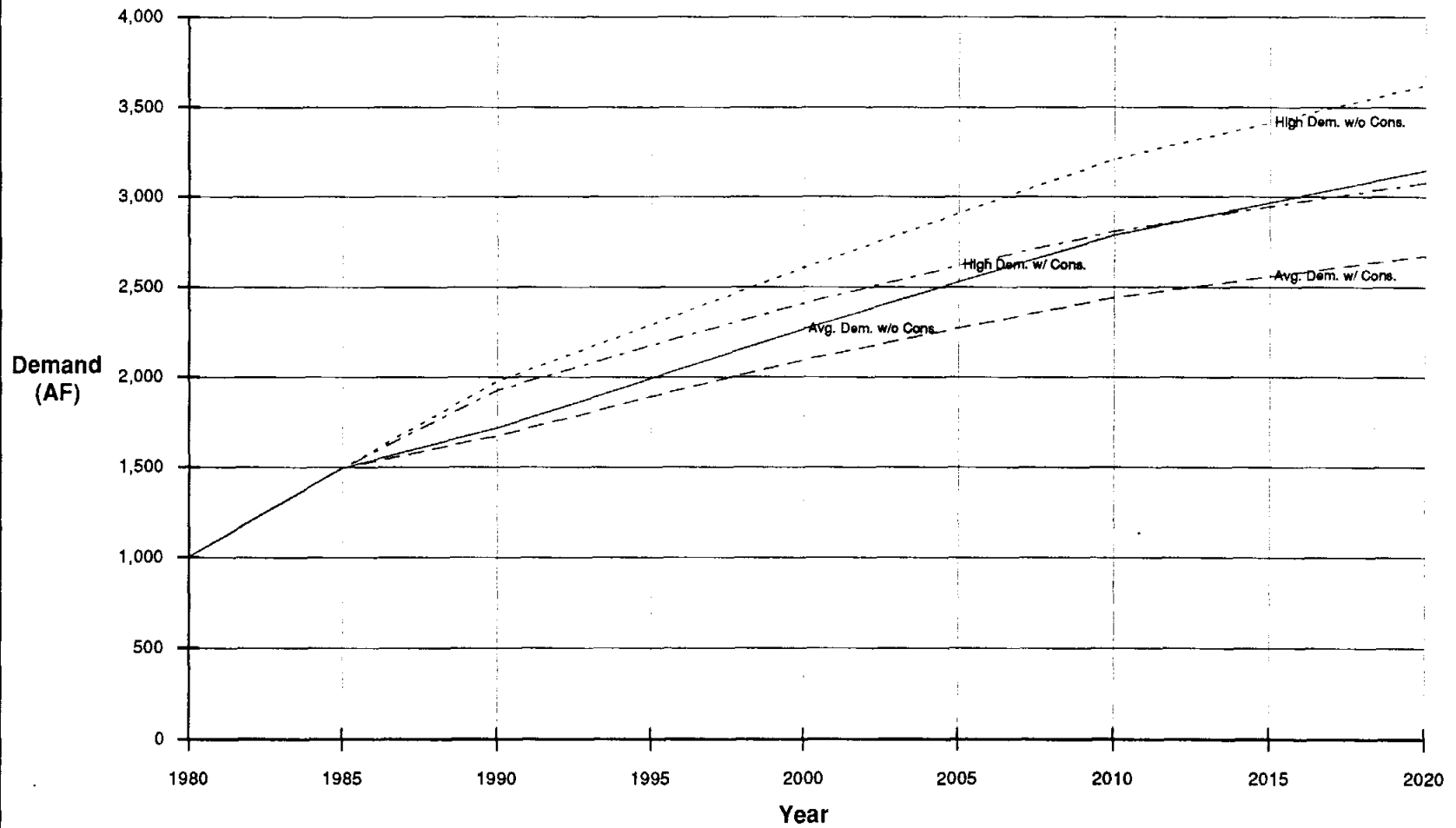

Figure 3-6  
Green Valley WSC Future Demands  
High Population Series

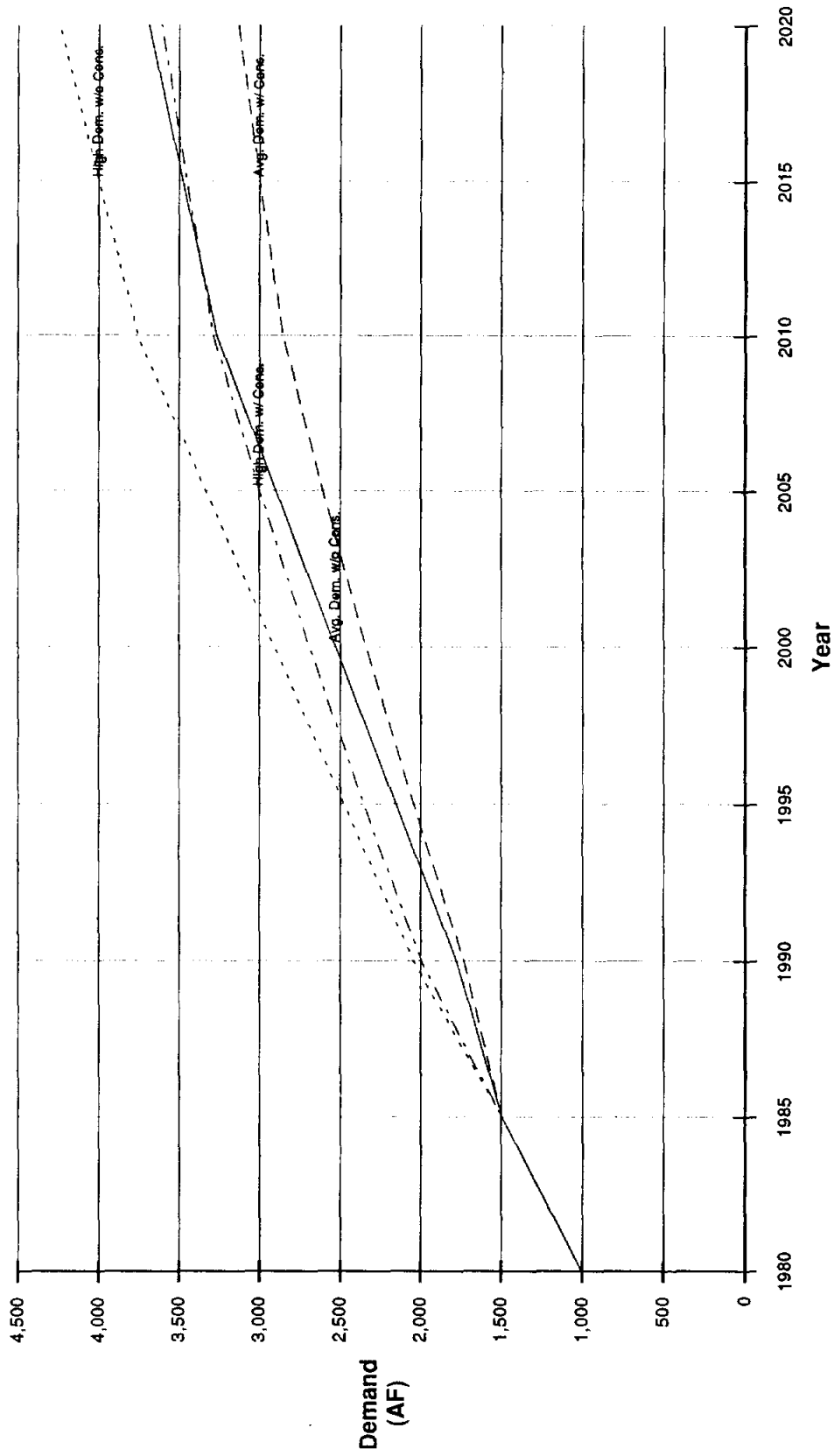



Figure 3-7  
Springs Hill WSC Future Demands  
High Population Series

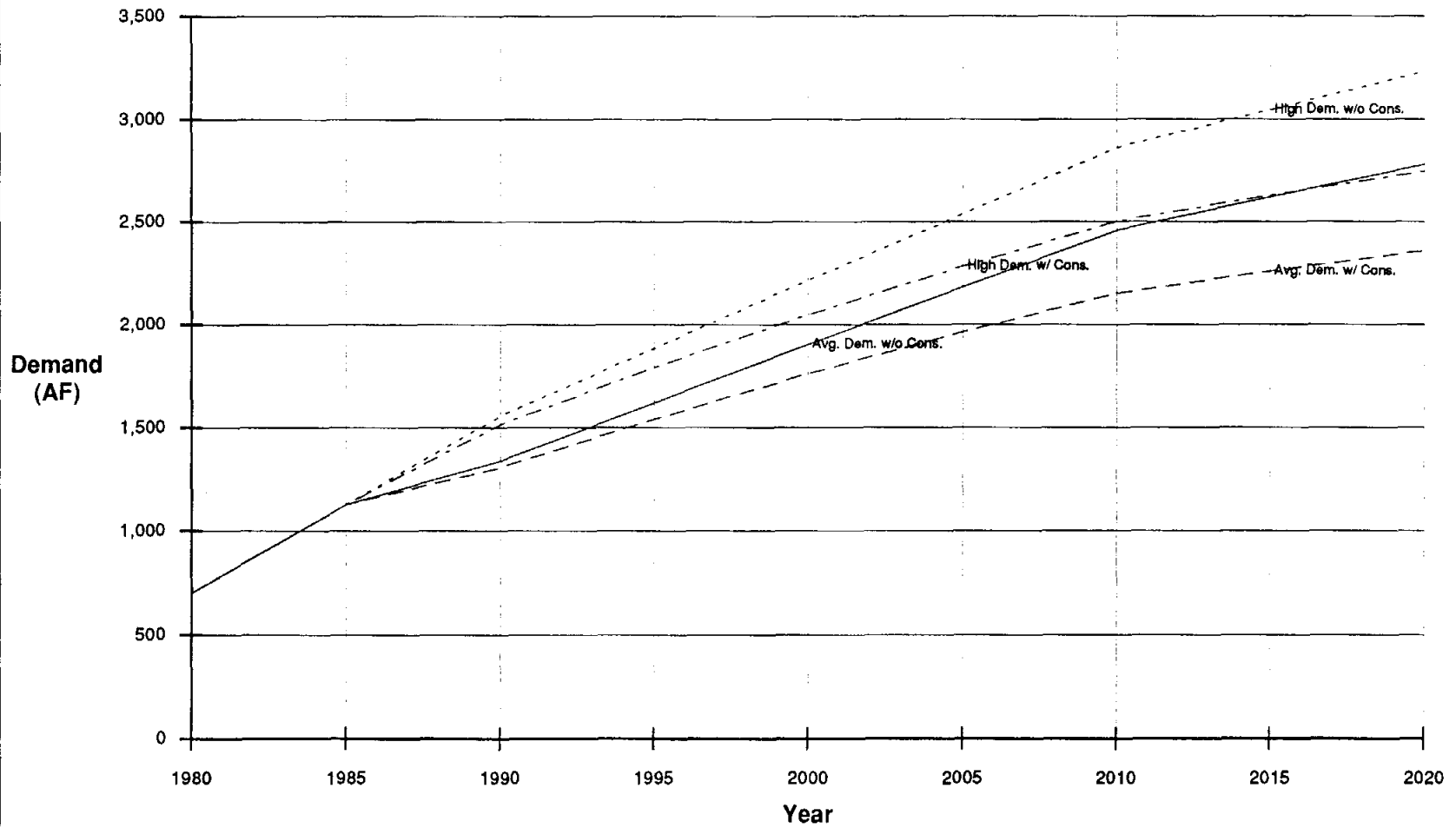

Figure 3-8  
Springs Hill WSC Future Demands  
Low Population Series

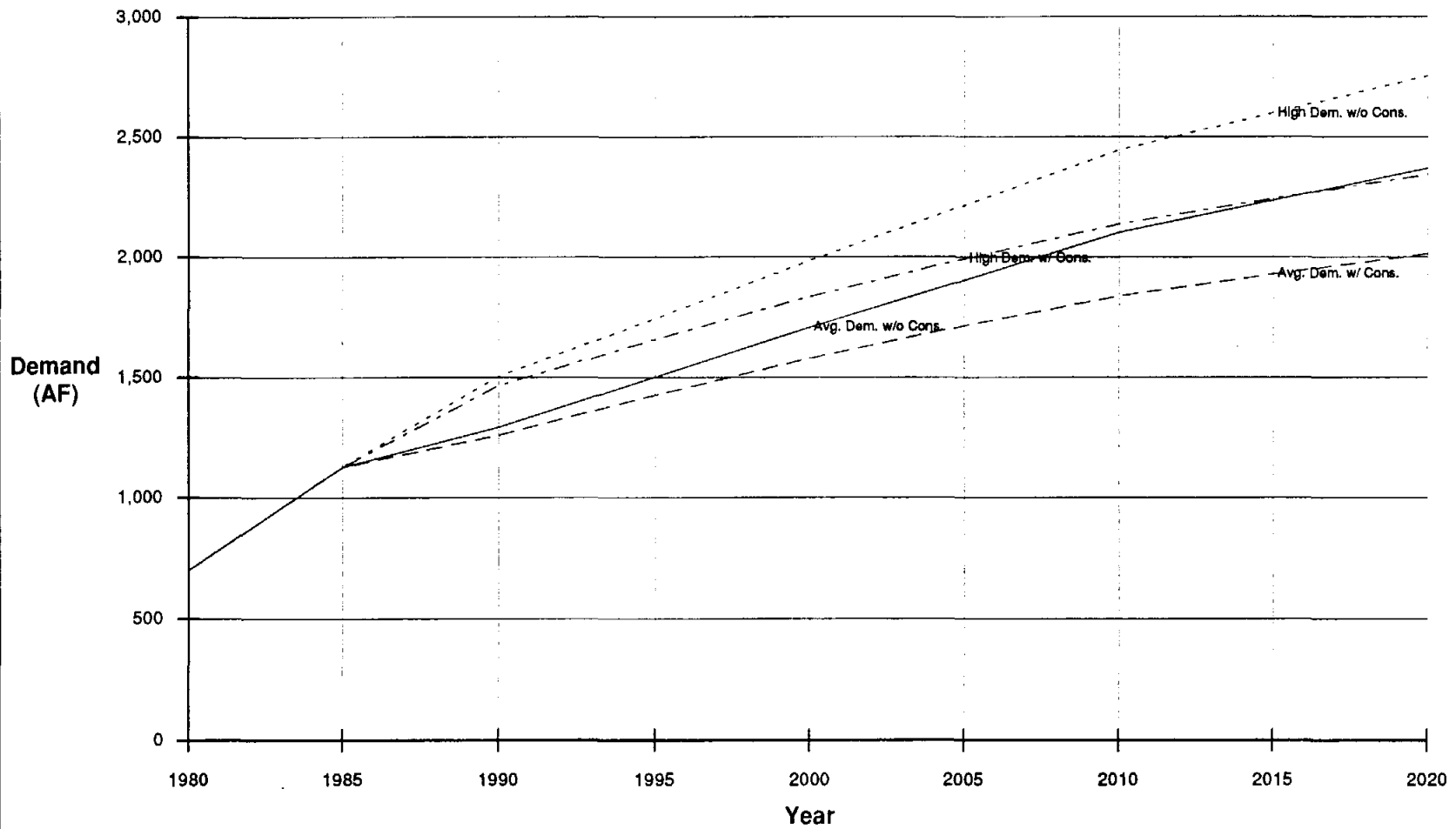

Figure 3-9  
Crystal Clear WSC Future Demands  
Low Population Series

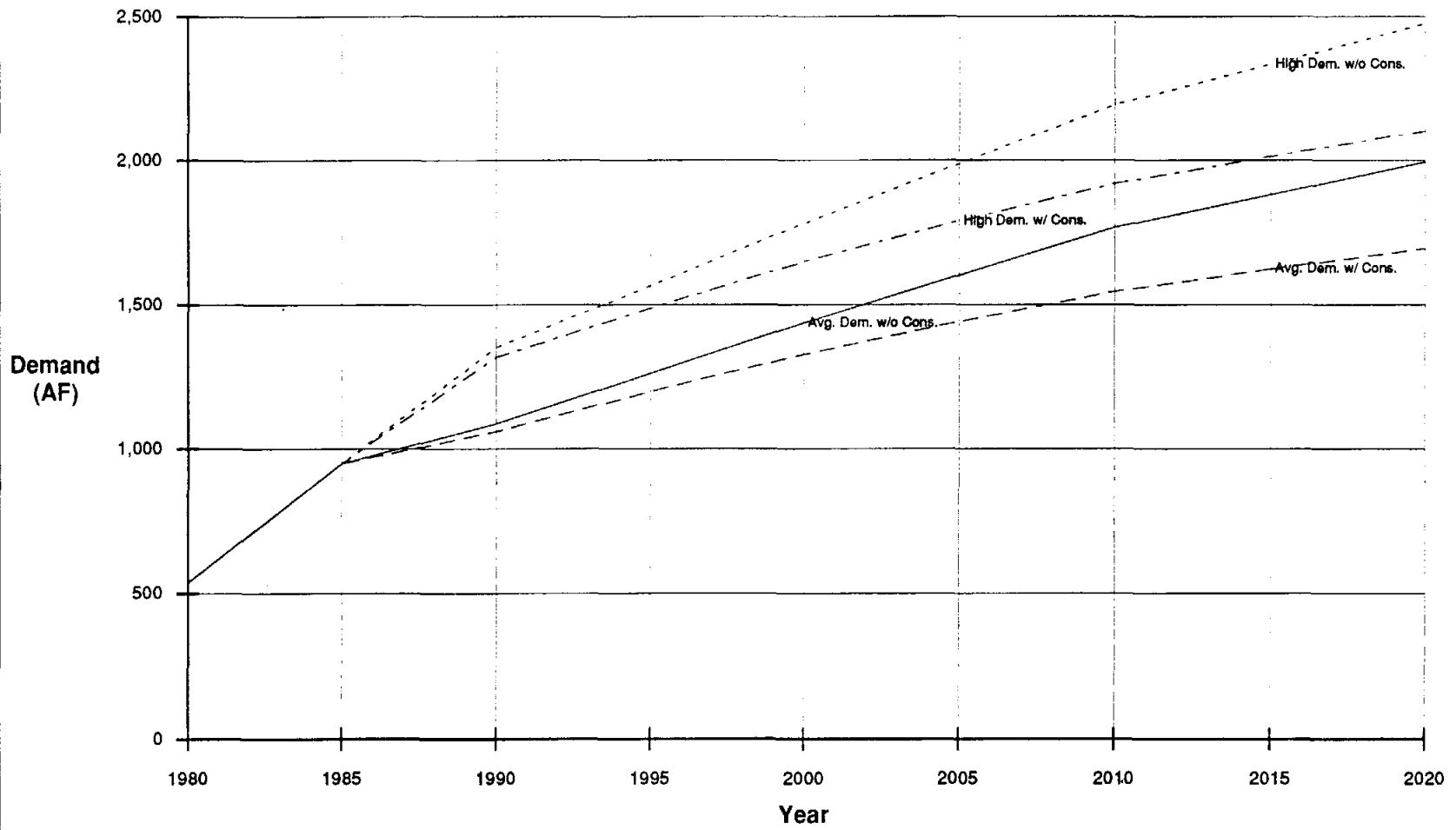

Figure 3-10  
Crystal Clear WSC Future Demands  
High Population Series

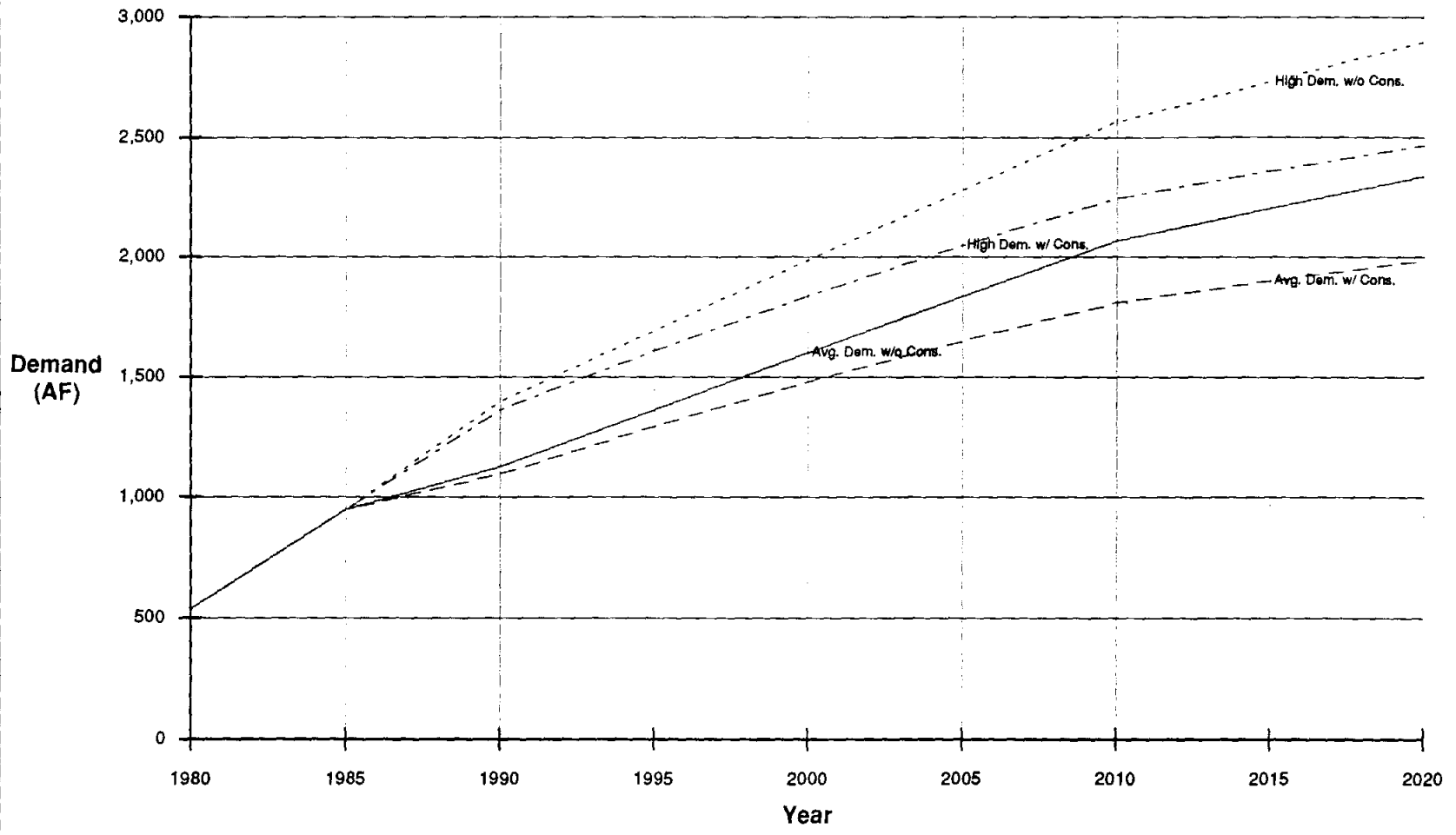

Figure 3-11  
East Central WSC Future Demands  
Low Population Series

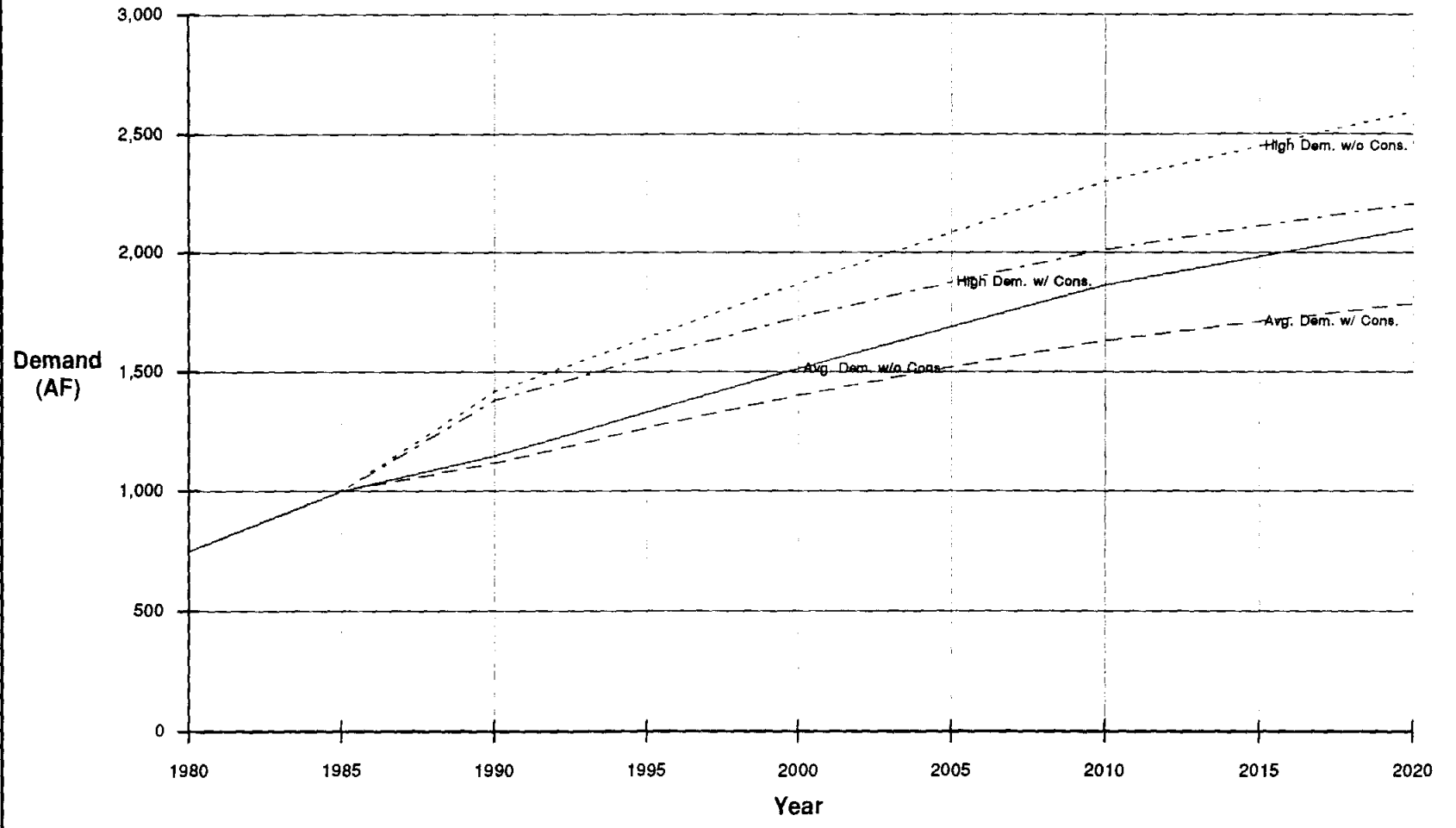

Figure 3-12  
East Central WSC Future Demands  
High Population Series

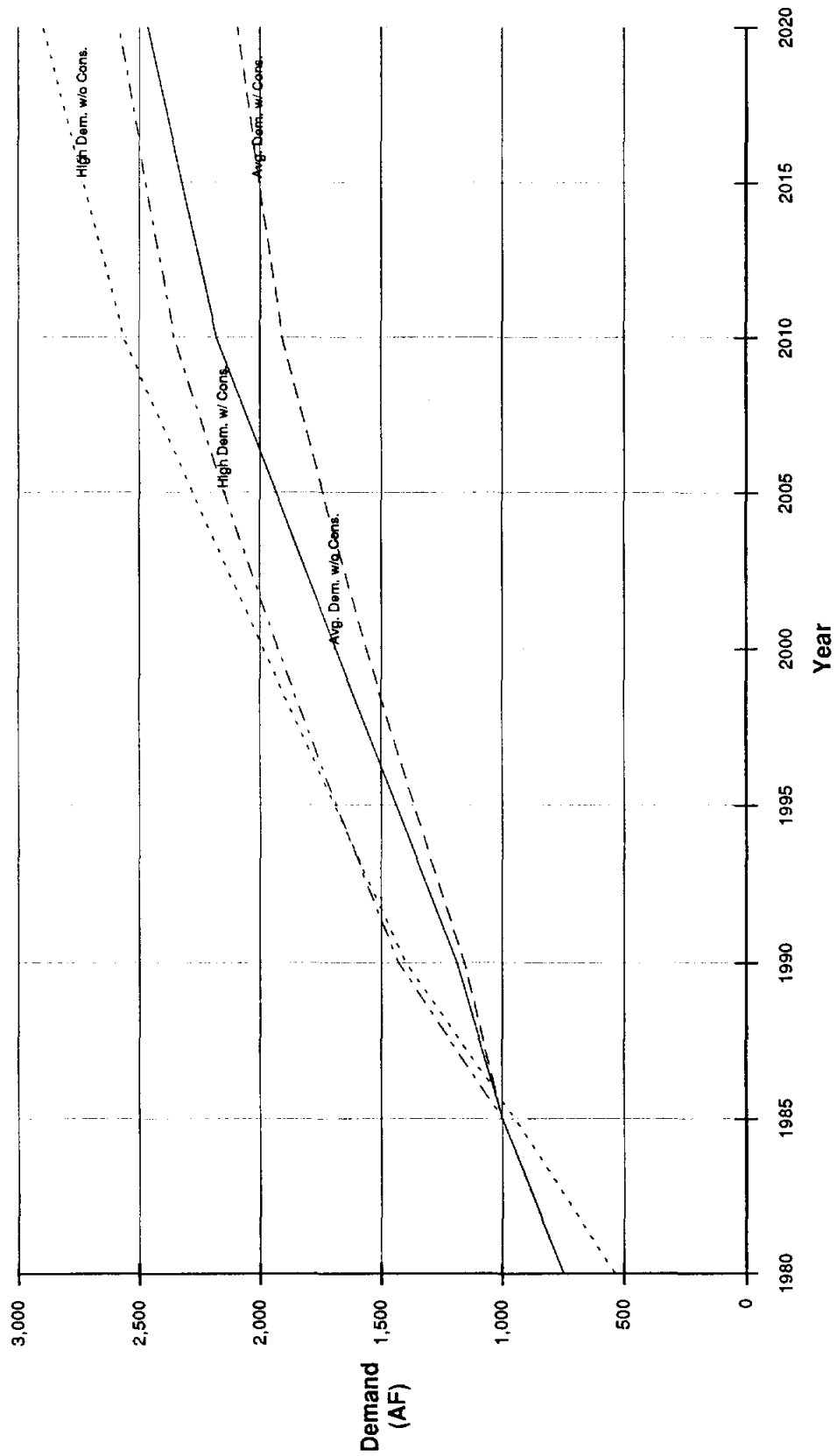

Figure 3-13  
Projected CRWA Member Future Water Demand  
Low Population Series - Average Per Capita Use  
Without Conservation

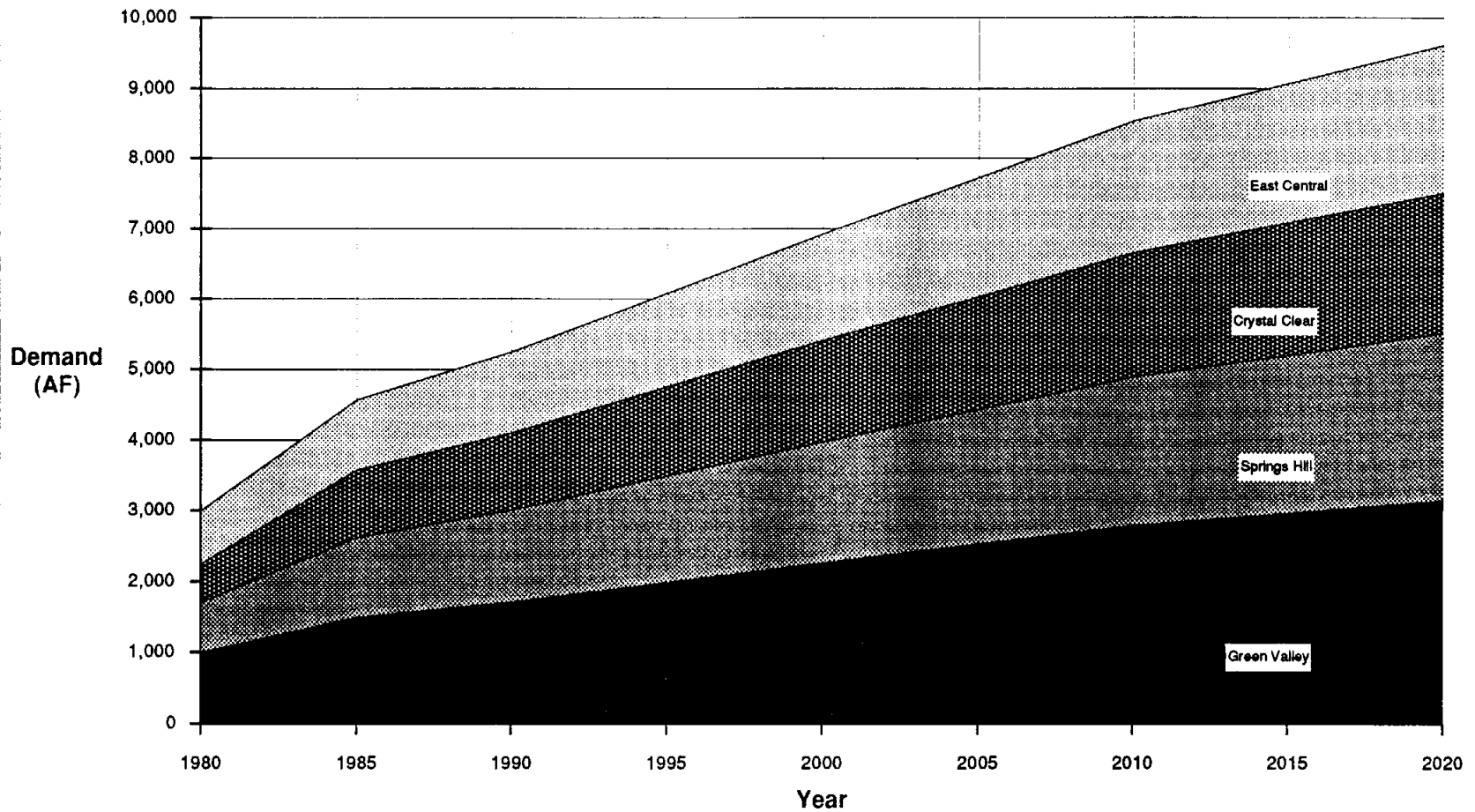

Figure 3-14  
Projected CRWA Member Future Water Demand  
Low Population Series - Average Per Capita Use  
With Conservation

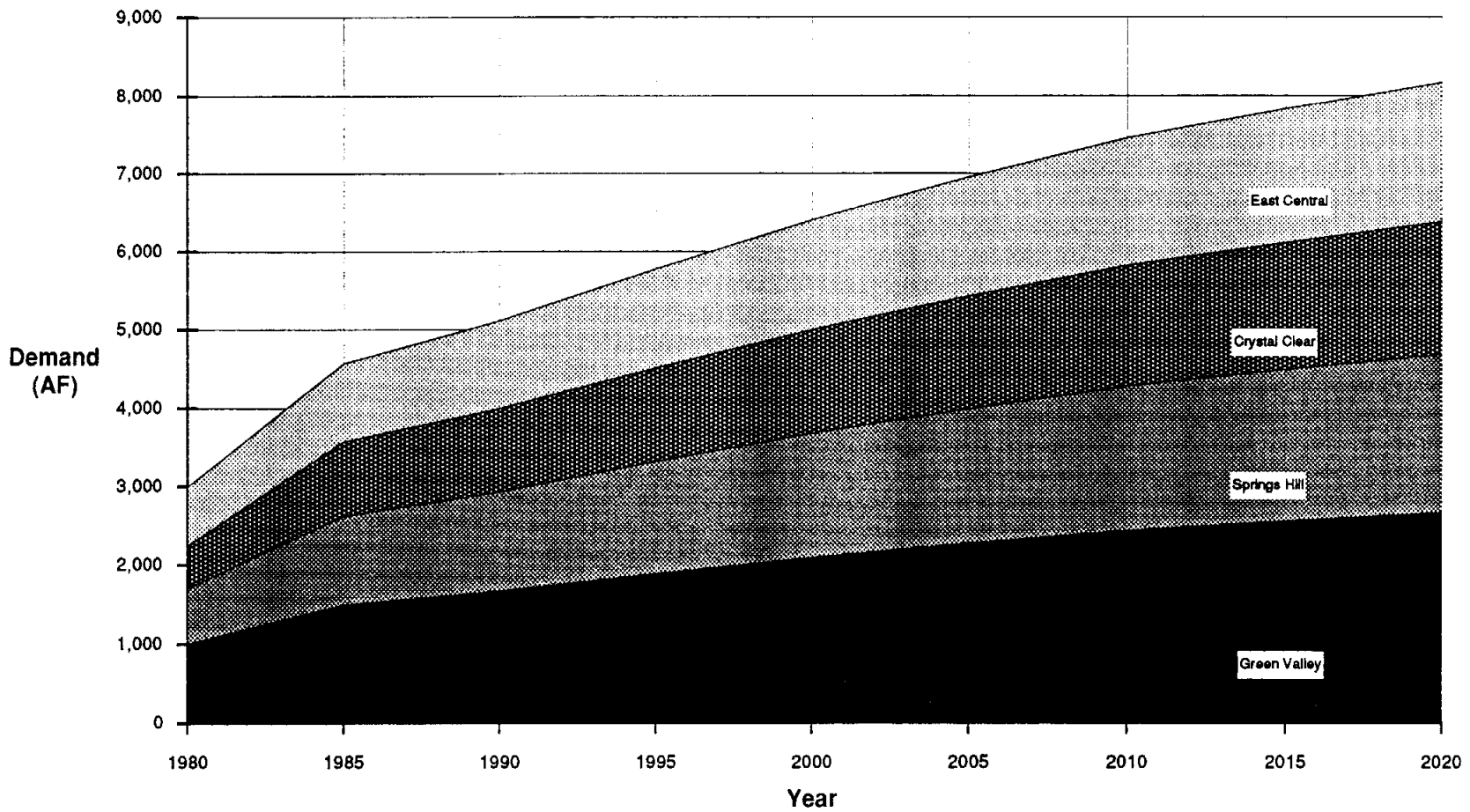



Figure 3-15  
Projected CRWA Member Future Water Demand  
Low Population Series - High Per Capita Use  
Without Conservation

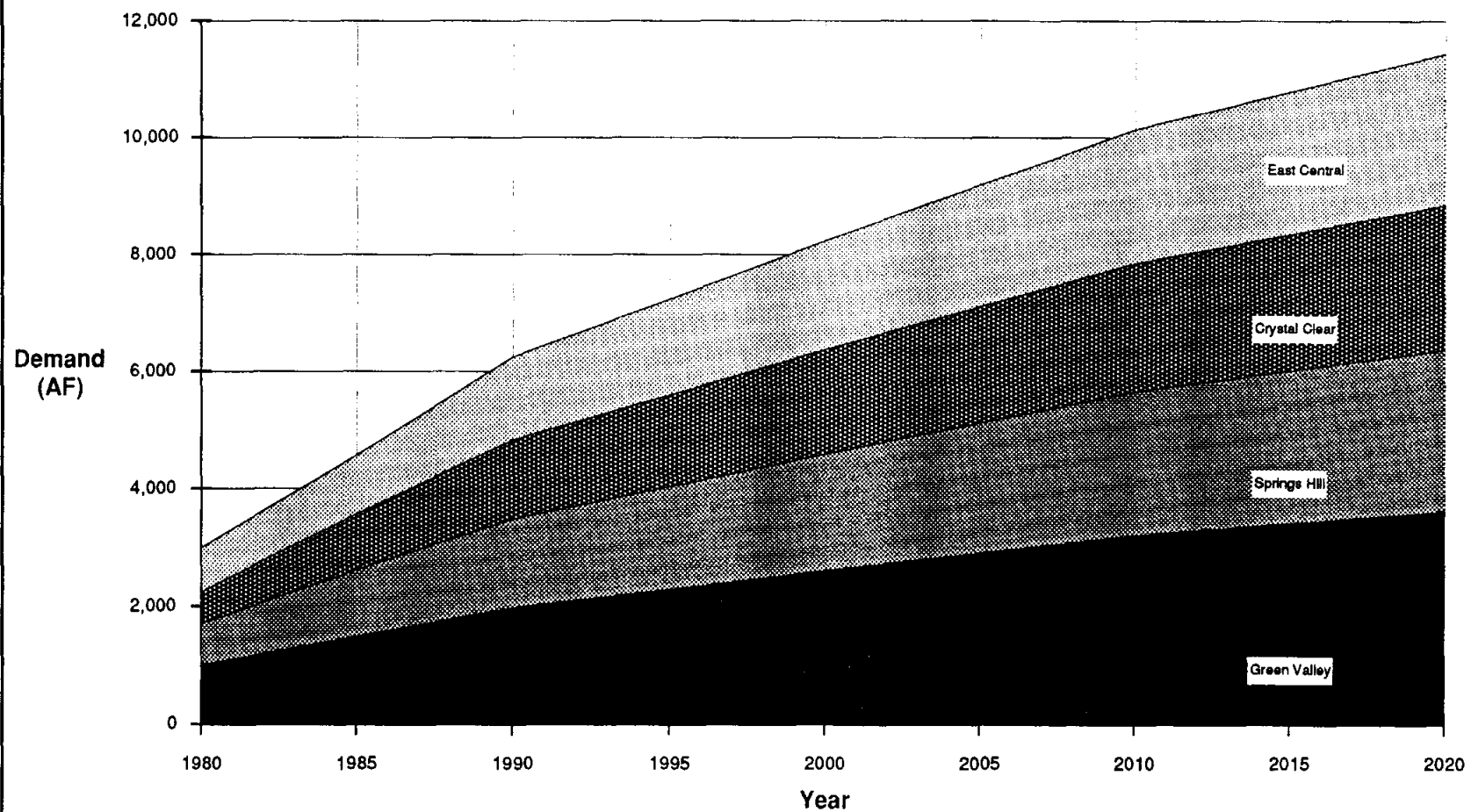

Figure 3-16  
Projected CRWA Member Future Water Demand  
Low Population Series - High Per Capita Use  
With Conservation

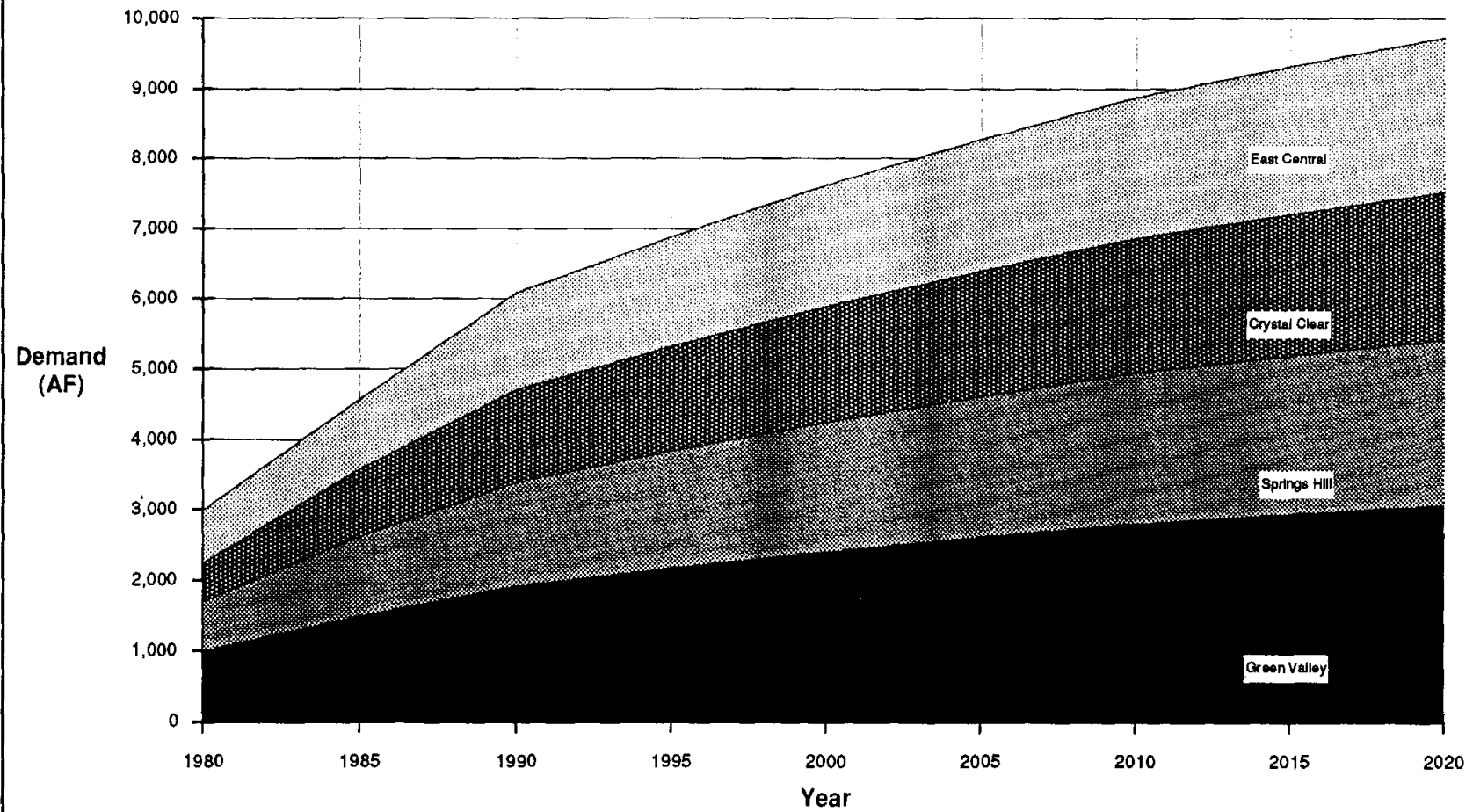

Figure 3-17  
Projected CRWA Member Future Water Demand  
High Population Series - Average Per Capita Use  
Without Conservation

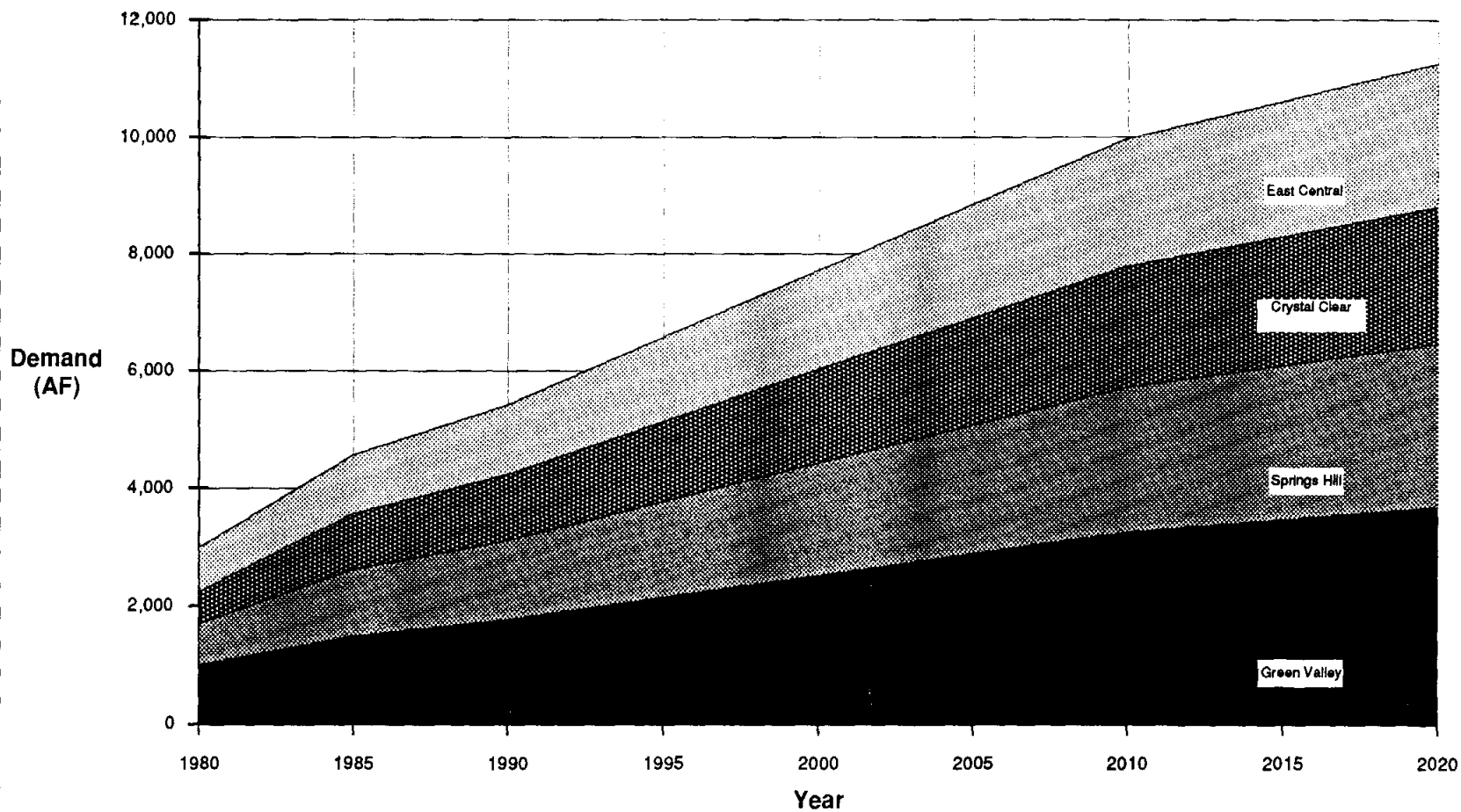

Figure 3-18  
Projected CRWA Member Future Water Demand  
High Population Series - Average Per Capita Use  
With Conservation

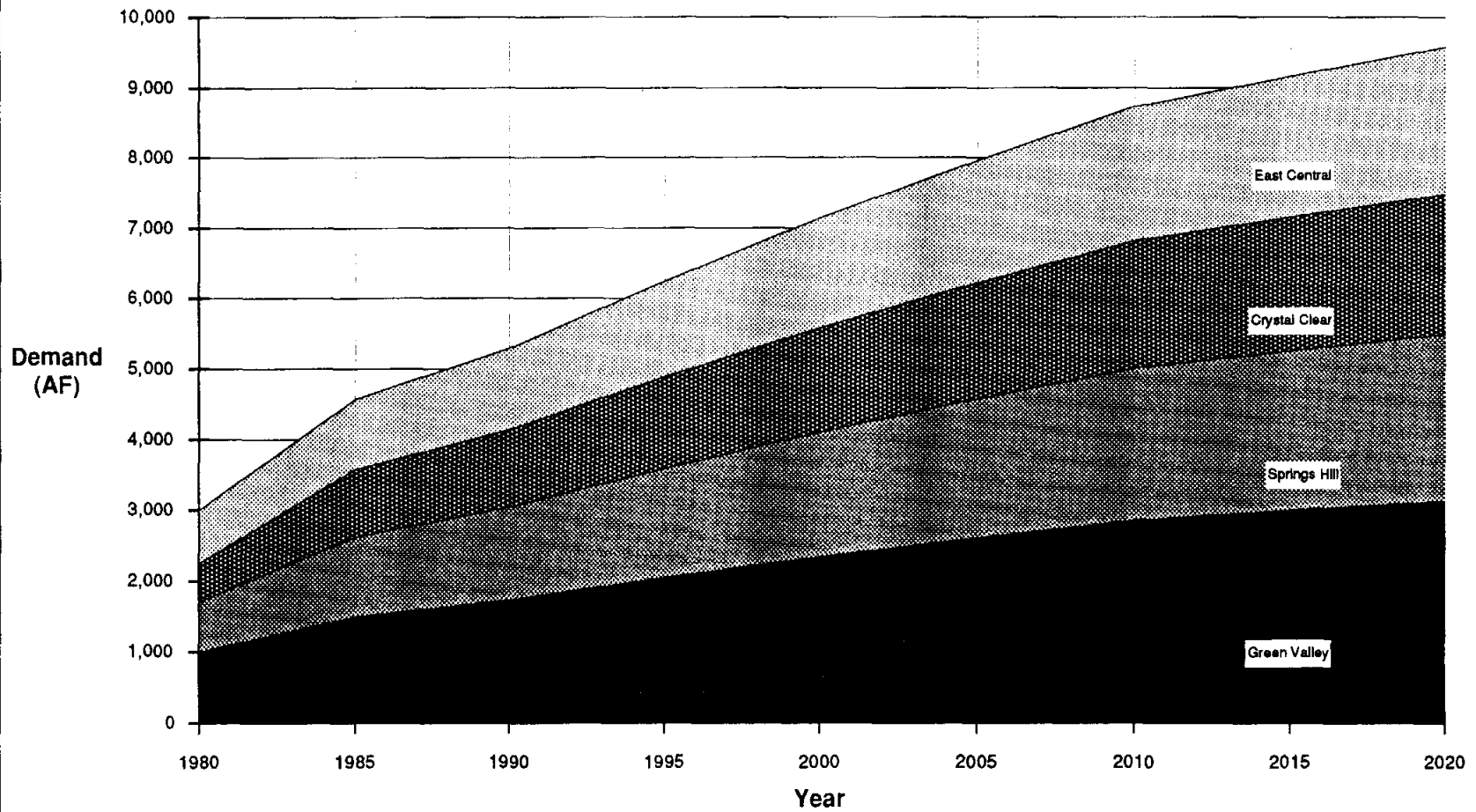

Figure 3-19  
Projected CRWA Member Future Water Demand  
High Population Series - High Per Capita Use  
Without Conservation

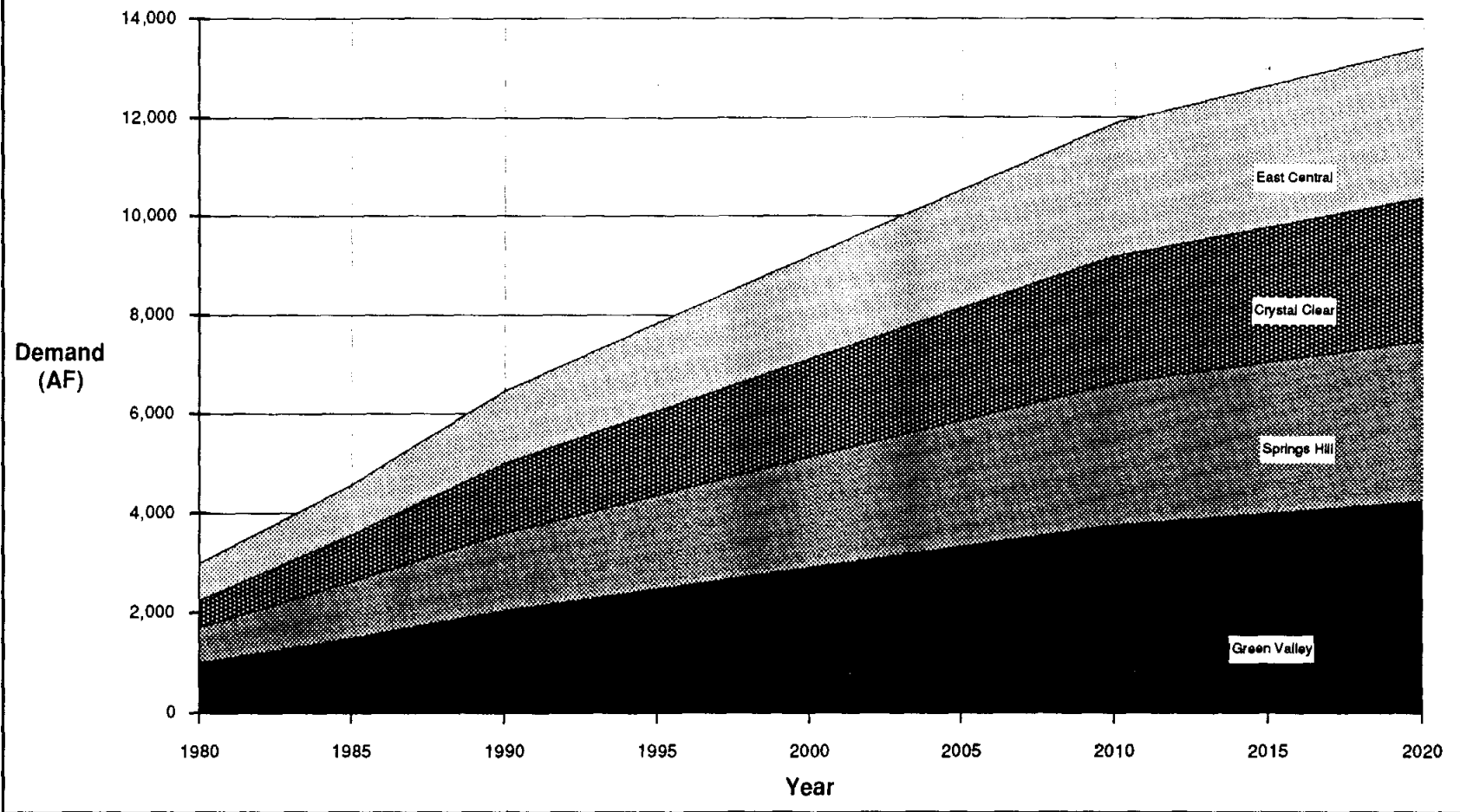
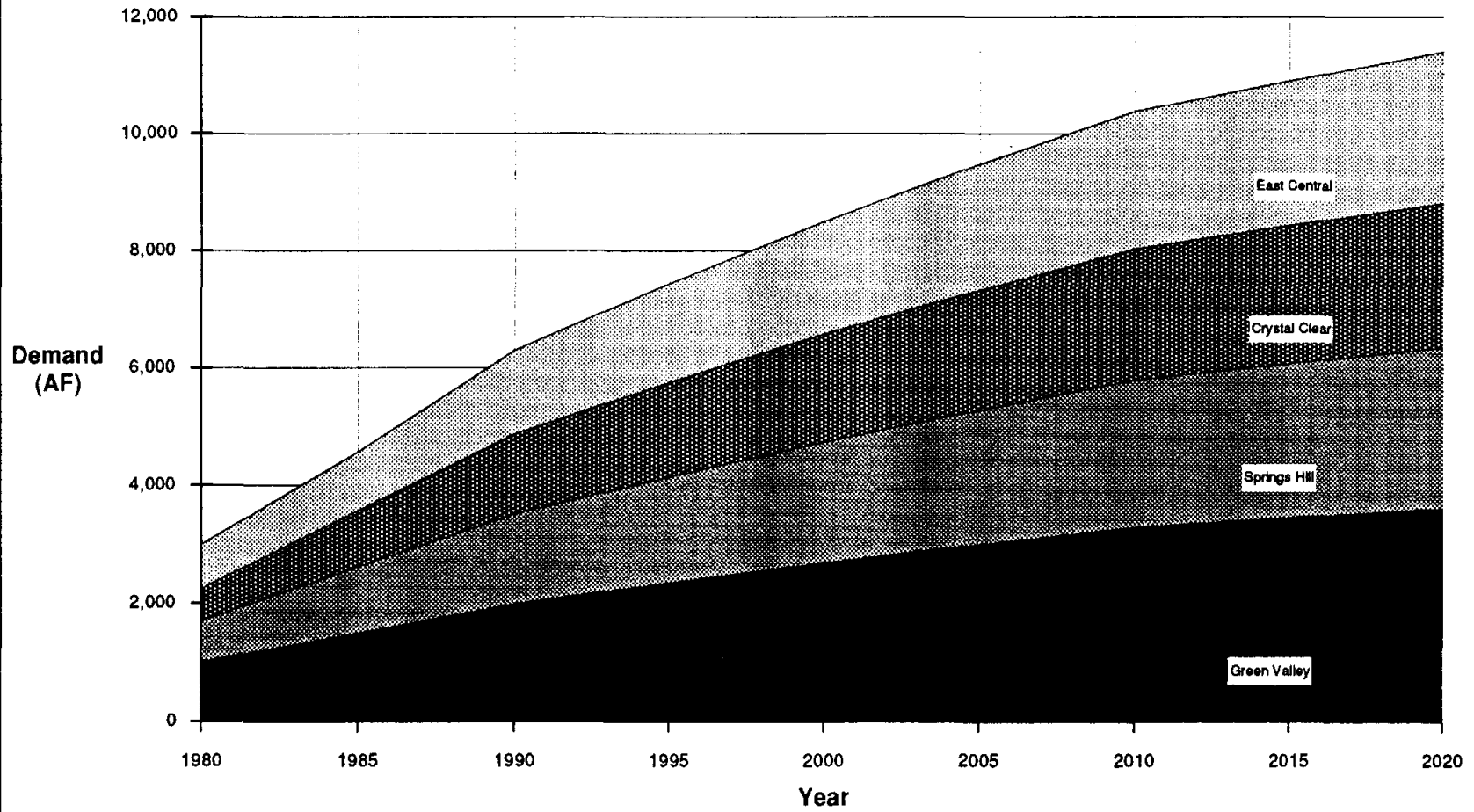

Figure 3-20  
Projected CRWA Member Future Water Demand  
High Population Series - High Per Capita Use  
With Conservation



### **3.3 Selection of Future Development Planning Scenarios**

Planning for future water supply acquisition and future treatment plant and distribution infrastructure designs require different uses of the same information. If in planning for the acquisition of firm future water supplies, future demands are over or underestimated, adjustment can usually be made to either liquidate excess capacity or obtain additional supplies from alternative sources (though this luxury may not be affordable in the tight Central Texas surface water market). However, if future water treatment or distribution capacities are underestimated the results can be costly. Additional capacity, at some future date, may be considerably more expensive than the initial cost of oversizing distribution system lines. Maintaining excess or unused treatment and distribution capacity can be equally expensive. Therefore the High Population Series/High Per Capita Use Rate/With Water Conservation future water demand estimates will be used in the remainder of this study. To minimize the possible economic impacts of over or underestimation of future populations and water demands, all water supply and infrastructure development scenarios examined will be phased.

## 4.0 WATER CONSERVATION

### 4.1 Introduction

#### 4.1.1 Planning Area and Project

The service area of the CRWA is generally described as the majority of rural Guadalupe County with smaller portions of service area in Hays, Bexar, Wilson, and Comal Counties. The total service area measures approximately 618 square miles. The vast majority of the watershed area is in the Lower Guadalupe Basin; however, a small portion lies in the San Antonio River Basin.

The overall objective of the study is to determine the availability and adequacy of surface water supplies available to CRWA member WSCs and to develop options for future supply acquisition and distribution infrastructure development consistent with the TWDB goal of reducing Edwards Aquifer groundwater use by entities not directly over the formation. Given that additional treatment capacity will be needed, cost estimates will be determined for various alternative development scenarios. These include the phasing in of different-sized treatment plants at a variety of locations. This section we describes water conservation measures that could have an impact on projected water supply demands and phasing of projects.

#### 4.1.2 Utility Evaluation Data

Green Valley Water Supply Corporation encompasses an area of approximately 160 square miles south and southeast of the City of New Braunfels. Green Valley provides service to approximately 11,000 persons through 4,189 connections. The majority of the service area is within Guadalupe County; although, service is provided to portions of Bexar and Comal Counties. Green Valley obtains its water from two groundwater sources and through an interconnect to the City of New Braunfels. Green Valley also provides water to the City of Cibolo through an interconnect.

Based upon the results of the most recent sanitary survey conducted by TDH, dated August 16, 1989, Green Valley meets or exceeds State minimum requirements, for well capacity, pressure storage, elevated storage, total storage, and high service pump capacity. It should be noted, however, that TDH evaluates well pump capacity based on the rated capacity of the pumps and not on the tested capacity. If the values contained in the sanitary survey for tested pump capacity are used to evaluate well pump capacity, Green Valley would be found to be deficient in well pump capacity by 117 gpm. Garcia and Wright Consulting Engineers, Inc. in their report entitled Green Valley Water Supply Corporation - 1989 Facility Evaluation, performed an evaluation of well pumping capabilities and determined that Green Valley is deficient by approximately 393 gpm in well pumping capacity. Although there is some discrepancy in the amount, it is clear that, Green Valley is deficient in well pumping capacity. According to the Garcia and Wright's report, the supply deficits are compensated for by the interconnect with the City of New Braunfels.



CANYON REGIONAL WATER SUPPLY STUDY  
WATER CONSERVATION

Springs Hill Water Supply Corporation serves an area of approximately 177 square miles in rural Guadalupe and Wilson Counties. The City of Seguin lies within the Springs Hill service boundary. Springs Hill provides service to 9,250 persons through 3,088 connections. Springs Hill is the only CRWA member which utilizes a surface water source: the Guadalupe River. The Guadalupe River treatment plant serves the southern, southeast, and southwest portions of the service area. An interconnect with the City of New Braunfels serves the northern portion of the service area. Springs Hill also maintains an interlocal agreement with the City of Seguin whereby both parties provide service to each other's system, as needed.

The most recent sanitary survey conducted by TDH, dated September 14, 1988, concludes that Springs Hill meets or exceeds State minimum requirements for pressure storage, elevated storage, total storage, and high service pump capacity. Based upon maximum daily usage, however, the system fails to meet required treatment capacity with a deficit of approximately 158,000 gallons per day.

Crystal Clear Water Supply Corporation serves the rural areas of Guadalupe, Comal, and Hays Counties generally bounded by the City's of Seguin, New Braunfels, San Marcos, and Luling. Crystal Clear WSC services 8,349 persons through 2,783 connections within its approximately 171 square mile service area. Although a majority of its water is obtained through self-maintained groundwater sources, Crystal Clear also maintains an interconnect with the Springs Hill Water Supply Corporation.

The most recent sanitary survey conducted by TDH for the system, dated March 29, 1989, concludes that the Crystal Clear system meets or exceeds State minimum requirements for well pump capacity, pressure storage, elevated storage, total storage, and high service pump capacity.

East Central Water Supply Corporation provides service to approximately 110 square miles in portions of rural Bexar, Guadalupe, and Wilson Counties. Service is provided to 7,998 persons through 2,666 connections. East Central obtains its total water supply from the San Antonio City Water Board via an interconnect agreement. East Central is the only member of the CRWA which does not have water production facilities of its own.

The most recent sanitary survey of the system was performed on December 22, 1988. Due to its lack of water production facilities, only East Central is required to meet minimum requirements for elevated storage, total storage, and high service pump capacity. Of these three items, East Central meets only the total storage requirement. East Central is deficient in elevated storage by 27,000 gallons and based upon the number of connections served, it is deficient in high service pumping capacity by 2,512 gpm; however, existing pumping capacity exceeds the daily pumping requirement by approximately 1,996 gpm.

#### 4.1.3 Need for and Goals of Program

The Texas Water Development Board has promulgated Financial Assistance Rules which require water conservation planning for any entity receiving financial assistance from the Board. The origin of these requirements is HB 2 and HJR 6 passed by the 65th Texas Legislature in 1985 in order to encourage cost-effective regional water supply and wastewater treatment facility development. On November 5th, 1985 Texas voters approved an amendment to the Texas Constitution that provided for the implementation of HB 2. Previous to this study, the CRWA has not developed a comprehensive plan for water conservation or drought contingency management of available supplies. This document provides specific guidelines for developing a water conservation and drought management program that will meet the regulatory requirements of the TWDB for the CRWA Planning Area.

Since the early 1960s, per capita water use in the state has increased approximately four gallons per capita per decade. More important, per capita water use during droughts is typically about one third greater than during periods of average precipitation. Thus, the goals of the program are to reduce overall water usage through water conservation practices and to provide for a reduction in water usage during times of shortage.

Water use in the residential and commercial sectors involves day-to-day activities of all citizens of the state, and includes drinking, bathing, cooking, toilet flushing, fire protection, lawn watering, swimming pools, laundry, dishwashing, car washing and sanitation. In addition, rural areas, served by the CRWA member WSCs, carry the additional demands of supporting small-scale private livestock production and the, often not-so-small, family garden. The objective of a conservation program is to reduce the quantity of water required for each of these activities, where practical, through implementation of efficient water use practices. The drought contingency program provides procedures for both voluntary and mandatory actions placed in effect to temporarily reduce usage demand during a water shortage crisis. Drought contingency procedures include water conservation and prohibition of certain uses. Both are tools that CRWA member WSC managers and officials will have available to them in order to effectively operate in all situations.

The water conservation plan outlined below will have the overall objective of reducing water consumption in the CRWA Service Area. It will have the added advantage of reducing the amount of wastewater needing treatment and disposal. Although the impetus for this report is regional planning for water supply needs, it focuses on measures that specifically reduce the amount of water used and, ultimately, on the amount of wastewater produced. Such measures will have the effect of extending the time until additional water and wastewater treatment capacity must be provided.

CANYON REGIONAL WATER SUPPLY STUDY  
WATER CONSERVATION

Various cities throughout the country have adopted water conservation techniques and technologies depending upon the severity of their water supply situation. In particular, California has taken significant steps to reduce water consumption, and here in Texas, Austin has an aggressive water conservation program. Drawing on the experiences of some of these cities, we can make some assumptions about the feasibility, cost and effectiveness of specific measures. For the purpose of reducing the quantities of water required, two of the measures outlined below deserve particular attention: adopting vigorous plumbing codes for new construction and retrofitting.

According to figures developed in Section 3.0, between 1990 and 2020, the population of the CRWA Planning Area is expected to at least double. Under drought conditions, when consumption is typically at its highest, and without implementation of water conservation measures, a doubling of the population would increase demand from its current 5,200 AF/yr to over 13,500 AF/yr. With such high rates of growth, it is evident that the greatest savings in water usage can be realized by adopting stringent plumbing codes for new construction. Nationwide it is being realized that the marginal cost of supplying new water sources and water and wastewater treatment facilities is so high, that new plumbing codes that reduce water usage by 25-30 percent are the most economical solution. However, because water use in rural areas are less weighted toward domestic functions, lesser reductions on the order of 10-15% can be expected.

Existing facilities can also be retrofitted in order to reduce water consumption. Although this may involve some capital outlay, all of the measures are cost-effective, and various schemes have been devised to recover the costs. For instance, a plan for San Antonio assumes that a 2 percent increase in water and wastewater rates for 5 years would raise enough money to cover a \$100 rebate for each customer retrofitting a toilet to flush on 1.5 gallons (resulting in an overall savings on the customer's water and wastewater bill). An aggressive retrofit program can result in water savings of 15-25 percent per residence. With market penetration typically running at 20-50 percent, this would result in an overall water consumption savings of around 5 percent. In its water conservation program, the City of Austin estimates a 6.7 percent savings within 5 years. This program consists of substituting low-flow shower heads, installing toilet dams and checking for leaks. The benefit/cost ratio is estimated at more than ten, with an average savings to the customer of \$52/year from reductions in water, wastewater and electricity.

In Figure 4-1, drought condition water demands through the year 2020 for the entire CRWA service area is shown without implementation of water conservation measures. Also shown are the flows that would result from the adoption of the two measures outlined above. Overall savings in wastewater flows by 2020 are approximately 15% or approximately 2,000 AF/yr. The assumptions made are:

**Figure 4-1**  
**Projected CRWA Total Water Demands With and**  
**Without Conservation**  
**High Per Capita Use/High Population Series**

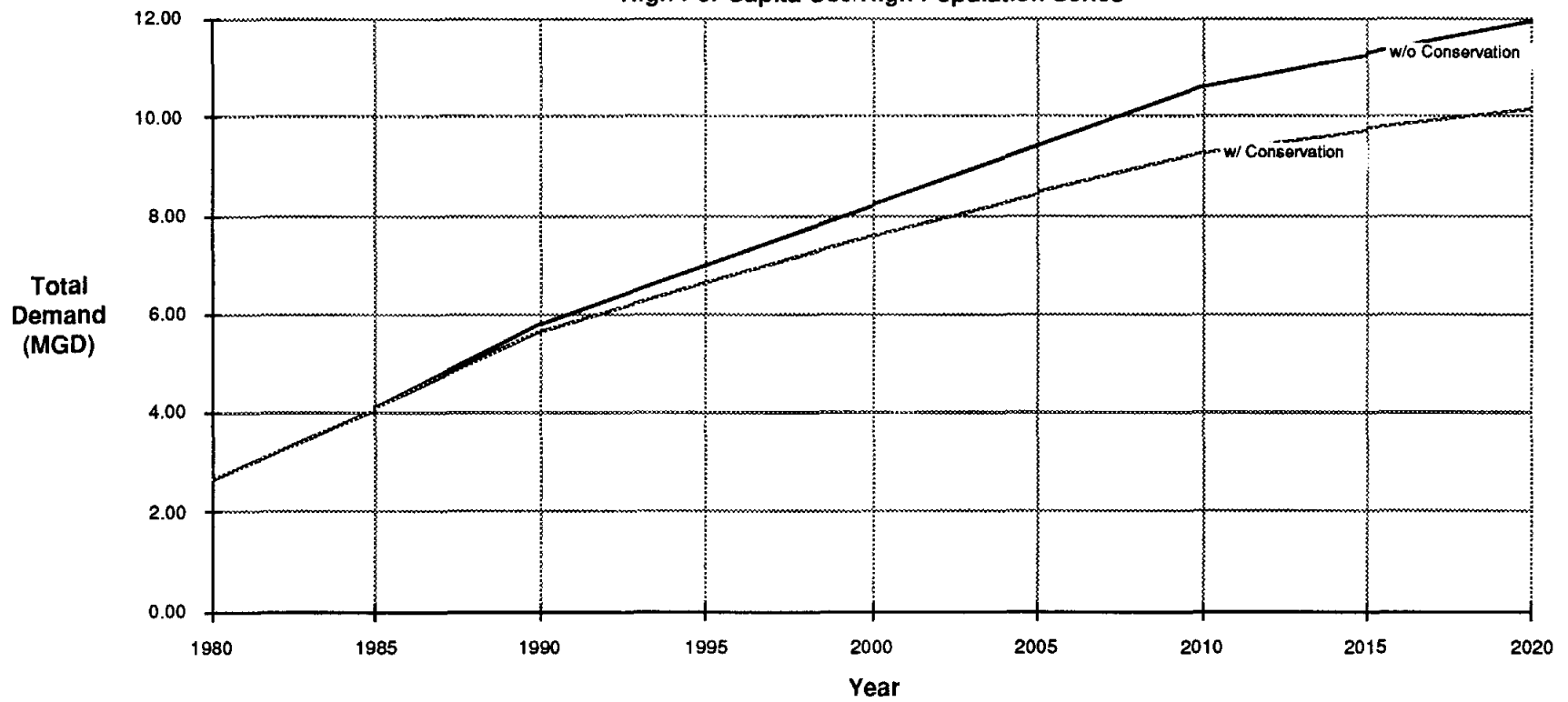

CANYON REGIONAL WATER SUPPLY STUDY  
WATER CONSERVATION

- adoption of a code that would reduce water consumption in all new construction from the current average of 140-160 gcd to 120 gcd;
- this code would be phased in during the 1990s and early 2000s ( a net water savings of 2% by 1995; 5% by 2000; 7-1/2% by 2005; 10% by 2010 12-1/2% by 2015 and 15% by 2020);
- existing uses could be reduced by 5 percent through retrofitting and other conservation measures.

These savings in water demand can be related directly to savings in water supply procurement, treatment and distributions costs as well as wastewater disposal costs. By reducing average daily demand and peak 2 hour demands by as much as 15% percent, water treatment and distribution system requirements will be commensurably reduced by 15% percent. New water treatment facilities cost roughly \$1,000,000/per million gallons of capacity. Therefore, a water savings of 2,000 AF/yr (1.79 MGD) will result in an unamortized savings of at least \$1,800, 000 plus reduced raw water and operation and maintenance. Operation and maintenance costs to the water system infrastructure will be reduced because of lower chemical requirements, reduced pumping requirements, and appropriate pump station and line sizing.

Design of urban water treatment and distribution systems are influenced more by fire protection requirements than average daily per capita water usage. Rural fire protection demands are less stringent; the Fire Protection Bureau requires a basic flow rate of 500 gpm. Thus, the impacts of water conservation are not diminished by fire protection requirements.

The drought contingency program (to be filed under a separate cover) includes those measures that can cause the CRWA to significantly reduce water use on a temporary basis. These measures involve voluntary reductions, restrictions and/or elimination of certain types of water use and water rationing. Because the onset of an emergency condition is often rapid, it is important that the CRWA be prepared in advance. Further, the citizen or customer must know that certain measures not used in the water conservation program may be necessary if a drought or other emergency condition occurs.

## **4.2 Long-term Water Conservation**

### **4.2.1 Plan Elements**

Nine principal water conservation methods are delineated as part of the proposed water conservation plan.

Education and Information

The CRWA will promote water conservation by informing water users about ways to save water inside of homes and other buildings, in landscaping and lawn maintenance, and in recreational uses. Information will be distributed to water users as follows:

**Initial Year:**

- The initial year shall include the distribution of educational materials outlined in the Maintenance Program section.
- Distribution of a fact sheet explaining the newly-adopted Water Conservation Program and the elements of the Drought Contingency Plan. The initial fact sheet shall be included with the first distribution of educational material.
- In addition to activities scheduled in the Maintenance Program, an outline of the program and its benefits shall be distributed either through the mail or as a door-to-door hand-out.

**Maintenance Program:**

- Distribution of educational materials will be made semi-annually, timed to correspond with peak summer demand periods. Such material will incorporate information available from the American Water Works Association (AWWA), Texas Water Development Board (TWDB) and other similar associations in order to expand the scope of this project. A wide range of materials may be obtained from:

Texas Water Development Board  
P.O. Box 13231, Capitol Station  
Austin, Texas 78711-3231

- New customers will be provided with a similar package of information as that developed for the initial year, namely, educational material, a fact sheet explaining both the Water Conservation Program and the elements of the Drought Contingency Plan, and a copy of "Water Saving Methods that can be Practiced by the Individual Water User."

Plumbing Codes

Each of the CRWA member WSCs currently adhere to and enforce independent plumbing code for their respective service areas. These Codes have been in effect for several years. During the 1990s a more stringent unified CRWA Plumbing Code, modeled after the Massachusetts Code, will be adopted for all new construction and remodelled structures. The most significant components under consideration are:

CANYON REGIONAL WATER SUPPLY STUDY  
WATER CONSERVATION

- showers used for other than safety reasons shall be equipped with approved flow control devices to limit total flow to a maximum of 3 gallons per minute (gpm);
- toilets shall use a maximum of 1.6 gallons per flush;
- urinals shall use a maximum of 1.5 gallons per flush.

**Retrofit Program**

The CRWA will make available, through its education and information programs, pertinent information for the purchase and installation of plumbing fixtures, lawn watering equipment and appliances. The advertising program will inform existing users of the advantages of installing water saving devices. The CRWA will contact local plumbing and hardware stores and encourage them to stock water conserving fixtures, including retrofit devices.

In addition, the CRWA will embark upon an aggressive retrofit program. Several alternatives are summarized in Table 4-1. Market penetration is based on the experience of other cities offering such programs. Savings are calculated on the basis of 2.9 persons per household for year 2020, a total of 26,651 residences in the CRWA Service Area.

**Table 4-1  
Expected Savings to the CRWA Member WSCs Through  
Implementation of a Water Use Retrofit Program**

Action	Cost Per House <sup>a/</sup>	Savings Per House <sup>b/</sup>	Penetration <sup>c/</sup>	Total Savings <sup>d/</sup>	Total Cost <sup>e/</sup>	Cost Per gpd <sup>f/</sup>
Distribution of Water Savings Kits <sup>g/</sup>	\$1.00	17.8 gpd	50%	113,261 gpd	\$6363	\$0.056
Vouchers for Shower Heads and Toilet Dams <sup>h/</sup>	\$8.00	36.9 gpd	20%	93,918 gpd	\$20,362	\$0.217
Installation of Shower Heads and Toilet Dams <sup>i/</sup>	\$20.00	37.6 gpd	50%	239,249 gpd	\$127,260	\$0.532
Refund for Replacing Toilets <sup>j/</sup>	\$200.00	44.2 gpd	10%	56,249 gpd	\$254,520	\$4.525

- <sup>a/</sup> Assumes two bathrooms per single-family residence.
- <sup>b/</sup> Based on 140 gpd and 2.9 persons per residence.
- <sup>c/</sup> Percentage of residences participating fully in the program.
- <sup>d/</sup> Based on current 12,726 residences in CRWA Service Area.
- <sup>e/</sup> Total Program Implementation cost.
- <sup>f/</sup> Cost per gpd saved.
- <sup>g/</sup> Assumes free distribution to all services area residences @ two kits per residence.
- <sup>h/</sup> Assumes participant retrieval of kits @ two kits per residence.
- <sup>i/</sup> Assumes installation by CRWA member WSC personnel or private contractors.
- <sup>j/</sup> Assumes \$200 per toilet.

The least cost alternative is to deliver two packages/house containing two flow restrictors, a plastic restrictor for a shower head, a toilet bag and two dye tablets. Based on past experience, the toilet bags are the most acceptable to customers and could be expected to realize savings of 4.8 gpd in participating households. A more acceptable and more permanent option is to provide customers with low-flow shower heads and toilet dams. Because of the greater costs associated with providing these items, vouchers would be included in the water bill to be exchanged at convenient locations for each WSC. It is assumed that most of the equipment claimed through this mechanism would be installed. Another more fool-proof system, used extensively in the City of Austin, involves the installation of low-flow shower heads and toilet dams at no charge to the customer. In Austin, market penetration has exceeded 50 percent and in participating households has resulted in water savings of around 15 percent. A fourth option is to provide rebates of \$100 to customers who replace their toilets with those that flush on 1.5 gallons.

#### Water Rate Structure

The structure of rates is as important as the rate itself in sending appropriate signals to consumers. There are about 20 different types of rate structures, some of which can be used in combination. Some rate structures encourage conservation; others discourage it.

Water systems which do not use water meters generally are a fixed charge. This rate structure uses rates which are the same for all users categories or are based on building types, sizes, values, frontages, or other measure. Rates may be collected as a separate bill, or may be merely included in property taxes. Fixed charges do not promote water conservation or economic efficiency, and they result in small users subsidizing large users. All CRWA customers are metered. No fixed rate structures are employed by CRWA member WSCs.

Another typical rate structure is a declining block rate design. With this structure, unit charges decrease as usage increases. Justification of declining block rates is based on economies of scale - as water use increases, it may cost less per unit to provide the water. However, perceived economies of scale may be fallacy for large users if their water demand results in a need for expanded supply or facilities. Declining block rates enhance revenue stability since the more variable components of demand are located in the tail blocks. But the declining block structure often results in prices which exceed cost of service in the initial blocks and which are less than the cost of service in the tail blocks. Declining block rates encourage wasteful water use and result in small users subsidizing large users.

A uniform commodity rate charges the same unit rate for all units consumed. Water bills go up and down proportionately with water use. The rate design provides some incentive to conserve average water use and is simple and equitable. This is the rate structure currently used by all four CRWA member WSCs.



CANYON REGIONAL WATER SUPPLY STUDY  
WATER CONSERVATION

There are two major forms of peak load pricing: seasonal pricing and peak demand pricing. Peak load pricing is used to reduce summer or peak demand. This structure is useful if there is a high peak or summer seasonal demand and if capacity investment or resource adequacy is determined by the peak demand. Peak load pricing helps to reduce the most "elastic" demands, such as watering outdoor plants. Peak load pricing help to reduce demand during critical water supply periods.

Seasonal rates are set higher every summer. They serve as an annual reminder to customers that rates will increase every year before the water short season. They also make it less likely that a customer will become accustomed to a permanently higher rate.

Peak demand pricing, sometimes called excess use pricing, is the charging of a significantly higher price for all water used above an average use. The average use may be an average for an entire user sector, or may be based on an individual user's average winter use.

Peak demand pricing may be structured differently for different user sectors in order to maintain equity.

Peak load pricing depends on frequent meter reading and prompt billing. Customers may not perceive the indirect message to conserve in their outdoor use if their summer water bill arrives in December. New remote meter reading technologies can be particularly useful if using peak load pricing.

Inverted block rates are designed so that as consumption increases, unit prices increase. This structure usually reduces average as well as peak demand, with residential use reductions of up to 10%. This structure sends consumers price signals to decrease incremental demands. It is particularly useful for utilities that expect a system expansion to drive up unit costs. There is a potential problem with cross-sectional equity, however, especially if large water users do not influence demand peaks. There are also concerns about large users potentially subsidizing small users. A utility contemplating inverted block rates might wish to set different block structures or different minimum fees for different water-using sectors.

Mixed or combined rate structures are frequently used. The most common mixed rate structure combines a flat or minimum charge with some sort of block rate structure. This type of rate structure is justified on grounds that a portion of the cost of service is fixed; once the capital structure are in place, the supplier has a fixed expense regardless of water consumption. The block rate portion would be set to cover the more variable cost components. Incentive to conserve with this mix of rate structures depends on how much of typical water demand is reflected in the variable portion of the water bill and what type of variable structure is used. When all or most of consumption lies within the minimum charge block, the rate essentially becomes a flat rate, with no incentive to conserve.

Another common mixed rate structure combines some form of peak demand rate with the regular rate structure. This can be done as a seasonal rate or as an excess consumption surcharge.

Other rate structures may apply to specific conditions:

- Lifeline pricing is sometimes used to maintain low rates for low-income residents or very low-volume water users to maintain affordable water for those least able to pay higher costs.
- Scarcity pricing is a form of an increasing block rate which adds the price for a depleting supply to the existing price. This may be effective if increased demand endangers a sole source of water supply or requires potential construction of an expensive additional supply.
- Sliding scale pricing is a modified form of increasing block rates in which, rather than charging higher rates for discrete blocks of use, the unit price for all water consumed increases with consumption.
- In developing areas, a spatial pricing system might be used to recoup the cost of expanding the system to serve a remote location or the higher expense of serving higher elevations.
- Hoop-up fees or added service charges are other ways to recoup the cost of additional services.

As supply expansion becomes more and more expensive, interest is growing about an economic concept known as "marginal cost pricing." The marginal price equals either the reduction in the total water bill resulting from saving one unit of water, or the increase in the total bill resulting from the last unit of water consumed. The marginal cost of supply equals the cost of providing the last unit of water. Average water rates are determined by the total costs of supplying all system users. Generally, the marginal water rate will not equal the marginal cost of supply.

To the supplier, the least expensive available water supply is the first used, and the actual cost of providing the last unit of supply may exceed the average cost. Because the actual cost of supplying the last unit is likely to be greater than the rate charged for that unit, economic signals lead to over-consumption. To the consumer, however, the most valuable units consumed are the first ones, and the last units consumed are the least valuable. Therefore, if the prices for the last units increase with the cost of supply, consumption will decrease.

Use of marginal cost pricing is particularly useful for water systems near demand capacity. The cost of expanding the system or the supply to meet additional demand should be reflected in the price as capacity is approached. Where expansion is actually needed, marginal cost pricing would result in a smaller capacity expansion than if average pricing is used.

For a system with excess capacity, the marginal cost of supply may actually be lower than the average cost due to economies of scale. The use of marginal cost pricing, then, will vary depending on how close system demand is to capacity. The varied nature of marginal cost pricing may make it impractical as an

CANYON REGIONAL WATER SUPPLY STUDY  
WATER CONSERVATION

exact pricing method. However, the actual cost of various units of supply should be considered as a part of rate-setting decisions, especially where demand approaches capacity.

Prices should be set to reflect the actual cost of service, including all costs associated with property, hardware, operations, maintenance and personnel. These costs should include depreciation of capital assets and needed planning expenses. Prices should not be hidden in property taxes, as this eliminates direct incentive for conservation.

There is little consensus regarding what pricing structures are most effective in encouraging conservation, however the following are known about consumer behavior. If a new pricing structure results in an unchanged total bill, there will be no response by the users. When prices do go up, response is delayed until bills are received. The initial response to higher rates may exceed the long term response if the perceived price impact is greater than the ultimate reality. If prices are too low in the first place, a price increase may have little impact on demand.

Equity among water use segments is an issue to consider when weighting pricing alternatives. Careful analysis should be made of the allocation of the total cost of supplying water to a community. Public participation in rate changing decisions is necessary to achieve political acceptability of the resulting rate.

A final point about rate hikes and revenues: Higher rates will result in increased net revenues, because elasticities are generally between zero and -1, and percent water use reductions will be less than percent price increases.

CRWA members are currently studying the myriad of conservation encouraging rate structure and will select a system that will most effectively serve the particular needs of their regional system.

Universal Metering

All water users, including utility and public facilities are currently metered. Also, master meters are installed and periodically calibrated at all existing water sources. All new construction, including multi-family dwellings, is separately metered. The program of universal metering will continue, and is made part of the Water Conservation Plan.

The CRWA member WSCs, through their computer billing system, currently monitors water consumption and inspects meters that vary from previously established norms. In addition, the CRWA will establish the following meter maintenance and replacement programs:

CANYON REGIONAL WATER SUPPLY STUDY  
WATER CONSERVATION

<u>Meter Type</u>	<u>Test and Replacement Period</u>
Master meter	Annually
Larger than 1 inch	Annually
1-inch and less	Every 5 years

Through a successful meter maintenance program, coupled with computerized billing and leak detection programs, the CRWA will be able to maintain water delivery rates, from production to consumer, in the 85 percentile range.

Water Conservation Landscaping

In order to reduce the demands placed on the water system by landscape, livestock and garden watering, the CRWA, through its information and education program, will encourage customers and local landscaping companies to utilize water saving practices during installation of landscaping, gardens and stock watering facilities for residential and commercial institutions. The following methods will be promoted by the education and information program:

- Encourage subdivisions to require drought-resistant grasses and plants that require less water.
- Initiate a program to encourage the adoption of xeriscaping.
- Encourage landscape architects to use drought-resistant plants and grasses; and efficient irrigation systems.
- Encourage licensed irrigation contractors to use drip irrigation systems, when possible, and to design all irrigation systems with conservation features such as sprinklers that emit large drops rather than a fine mist and a sprinkler layout that accommodates prevailing wind patterns.
- Encourage commercial establishments to use drip irrigation for landscape watering, when practical, and to install only ornamental fountains that use minimal quantities of water, including recycling features.
- Encourage local nurseries to offer adapted, drought-resistant plants and grasses and efficient watering devices.

Leak Detection and Repair

The CRWA and its member WSCs will utilize modern leak detection techniques, including listening devices, in locating and reducing leaks. Through their respective billing program, each WSC will identify excessive usage and take steps to determine whether it is a result of leakage. Once located, all leaks will

CANYON REGIONAL WATER SUPPLY STUDY  
WATER CONSERVATION

be immediately repaired. A continuous leak detection and repair program is vital to the WSC's profitability. The CRWA is confident that the program more than pays for itself.

Recycle and Reuse

The CRWA does not own or operate any conventional wastewater treatment facilities. Nearly all CRWA customers utilize some sort of on-site wastewater treatment and disposal method. However, the CRWA will make available to its customers, information on on-site reuse of non-sewage wastewater.

4.2.2 Implementation/Enforcement

The staff of the CRWA will administer the Water Conservation Program. They will oversee the execution and implementation of all elements of the program and supervise the keeping of adequate records for program verification.

The plan will be enforced through the adoption of the Water Conservation Plan by each of the CRWA member WSCs in the following manner:

- Water service taps will not be provided to customers unless they have met the plan requirements;
- The proposed block rate structure should encourage retrofitting of old plumbing fixtures that use large quantities of water; and
- The building inspector will not certify new construction that fails to meet plan requirements.

The CRWA member WSCs will adopt the final approved plan and commit to maintain the program for the duration of the CRWA's financial obligation to the State of Texas.

Annual Reporting

In addition to the above outlined responsibilities, the CRWA staff will submit an annual report to the Texas Water Development Board on the Water Conservation Plan. The report will include the following:

- Information that has been issued to the public.
- Public response to the plan.
- The effectiveness of the water conservation plan in reducing water consumption, as demonstrated by production and sales records.
- Implementation progress and status of the plan.

CANYON REGIONAL WATER SUPPLY STUDY  
WATER CONSERVATION

Contracts with Other Political Subdivisions

The CRWA will, as part of a contract for sale of water to any other political subdivision, require that entity to adopt applicable provisions of the CRWA's water conservation and drought contingency plan or already have a TWDB-approved plan in effect. These provisions will be through contractual agreement prior to the sale of water to the political subdivision.

## **5.0 FUTURE DEVELOPMENT PLANNING SCENARIOS**

### **5.1 Supply Conditions**

Potential water supply options have been developed for four possible future conditions. The supply conditions are categorized as best case, probable case, worst case, and drought condition. The "best case" scenario assumes the following:

- All existing groundwater permits will be renewed at current withdrawal levels through 2020.
- All grandfathered groundwater withdrawal rates will continue in perpetuity.
- The interconnect between Green Valley Water Supply Corporation (GVWSC) and New Braunfels Utilities (NBU) will continue through 1994 but terminate prior to 1995.
- The interconnect between Springs Hill Water Supply Corporation (SHWSC) and NBU will continue through 2019.
- The interconnect between East Central Water Supply Corporation (ECWSC) and the San Antonio City Water Board (SACWB) will extend through 2017.

The "probable case" scenario assumes the following:

- All existing groundwater permits will be renewed for one 10-year period and will expire prior to the beginning of 2005.
- All grandfathered groundwater withdrawal rates will continue in perpetuity.
- The interconnect between GVWSC and NBU will continue through 1994 but terminate prior to 1995.
- The interconnect between SHWSC and NBU will continue through 2019.
- The interconnect agreement between ECWSC and the SACWB will extend through 2017.

The "worst" case scenario assumes the following:

- All existing groundwater permits will expire prior to the beginning of 1995.
- All grandfathered groundwater withdrawal rates will continue in perpetuity.
- The interconnect between GVWSC and NBU will continue through 1994 but terminate prior to 1995.
- The interconnect between SHWSC and NBU will continue through 2019.

- The interconnect agreement between ECWSC and the SACWB will extend through 2017.

The "drought condition" scenario assumes the following conditions:

- All existing groundwater permits will expire prior to the beginning of 1995.
- All grandfathered groundwater withdrawal rates will continue in perpetuity.
- The interconnect between GVWSC and NBU will continue through 1994 but terminate prior to 1995.
- The interconnect between SHWSC and NBU will continue through 2019.
- The interconnect agreement between ECWSC and the SACWB will extend through 2017.
- Allowable groundwater pumpage from the Edwards Underground Water District (EUWD), for self-supplied groundwater users, will be restricted to 70 percent of the annual pumping rate recorded for 1984.

The drought condition supply scenario is an extension of the worst case scenario and is intended to reflect a potential absolute worst case condition. The EUWD, as authorized by House Bill 1942, has developed a Drought Management Plan that must be implemented by all water purveyors, with more than 35 connections, who obtain water from the Edwards Aquifer and associated limestone formations within the EUWD. The EUWD has developed reduction goals and minimum demand restriction measures for five stages of drought severity. Table 5-1 is from the Draft Edwards Underground Water District Proposed Rules for Drought Management, dated September 1, 1989, and presents a summary of "trigger conditions" and "response goals" for the five stages of drought severity. The drought condition supply scenario assumes a Stage IV- Aquifer Risk condition. The Stage IV-Aquifer Risk drought condition requires a target pumpage volume reduction goal of 30 percent for municipal users. The following is taken from the Draft Edwards Underground Water District Rules for Drought Management:

"The reduction goal percentage will be applied to the volume pumped by each user in 1984 to determine a target pumpage volume for that user. The target pumpage volume is the total amount which can be used during any successive 12-month period unless either a more restrictive or a less restrictive drought management stage is declared. The target pumpage volume may be prorated over the coming year by the user in accordance with the user's requirements."

The drought condition scenario applies only to GVWSC and Crystal Clear Water Supply Corporation (CCWSC), since neither SHWSC nor ECWSC maintain groundwater production facilities.



**Table 5-1  
Drought Management Plan  
Trigger Conditions and Response Goals**

TRIGGER CONDITIONS					RESPONSE (1)							
Water Levels (3) (ft mgl)			Springflow (cfs) (6)		EAST				WEST			
Rainfall (in) (2)	Uvalde (4)	Bexar (5)	San Marcos	Comal	Stage	Reduction Goal			Stage	Reduction Goal		
						Mun	Ind/Misc	Irrig		Mun	Ind/Misc	Irrig
<80% of historic average	>870	<644	110	160	I-Awareness	10%	(7)	(8)	I-Awareness	None	None	None
		<628	80	70	II-Watch	15%	(7)	(8)	II-Watch	None	None	None
		<612	50	0(9)	III-Alert	25%	(7)	(8)	III-Alert	None	None	None
	>870	<644	110	160	I-Awareness	10%	(7)	(8)	I-Awareness	10%	(7)	(8)
		<628	80	70	II-Watch	15%	(7)	(8)	II-Watch	10%	(7)	(8)
		<612	50	0(9)	III-Alert	25%	(7)	(8)	III-Alert	10%	(7)	(8)
	>840	<644	110	160	II-Watch	15%	(7)	(8)	II-Watch	15%	(7)	(8)
	>829	<628	80	70	III-Alert	25%	(7)	(8)	III-Alert	25%	(7)	(8)
	>811	<612	50	0(9)	IV-Risk	30%	(7)	Reduce pumpage to 2 ac-ft/acre/yr	IV-Risk	30%	(7)	Reduce pumpage to 2 ac-ft/acre/yr
	(10)	(10)			V-Emergency	(11)	(11)	(11)	V-Emergency	(11)	(11)	(11)

- (1) Stages are defined for areas east and west of the Bexar/Medina county line.
- (2) The sum of the Uvalde and San Antonio rainfall for the last 12 months. Uvalde rainfall is measured at the National Weather Service gage (41-9268-6) located at the Texas A&M Research Experiment Station in Uvalde. San Antonio rainfall is measured at the National Weather Service gage (41-945-7) located at the San Antonio International Airport.
- (3) Water levels are calculated as 10-day moving averages.
- (4) Well YP-69-50-302.
- (5) Well AY 68-37-203 (J-17).
- (6) San Marcos and Comal springflows are correlated to Well AY 68-37-203 (J-17).
- (7) Industrial, commercial and military users will be encouraged to meet the reduction goals in Table 2-2 and to consider reuse, recycling and alternative or supplemental water supply sources. They will be required to comply with the landscape irrigation, golf course, swimming pool, aesthetics and other outdoor use restrictions.
- (8) The District anticipates that irrigation pumpage will be reduced because of lowered pump efficiencies, and voluntary cessation or reduction in volume pumped energy costs. The District has chosen, therefore, not to quantify the reduction until Stage IV-Aquifer Risk is declared. The District will monitor reported irrigation pumpage to evaluate whether reductions actually occur before Aquifer Risk limits are imposed.
- (9) Comal Springs ceases to flow when the water level in Bexar County (J-17) is approximately 620 feet.
- (10) Unacceptable deterioration of water quality.
- (11) Specific reduction goals will be established by the District based on measures needed to protect human health and safety and livestock watering.
- NOTE: The District will exercise discretion in determining stages when conditions are not as described.
- Source: Draft Edwards Underground Water District Proposed Rules for Drought Management, September 1, 1989

Individual Canyon Regional Water Authority WSC member demands have been developed through the year 2020 based on the High Population Series/High Per Capita Use Rate/With Water Conservation (H/H/W) future water demand estimates as presented in Chapter 3, of this study. Combined Canyon Regional Water Authority (CRWA) demands are the aggregate of individual member WSC demands. A comparison of the combined CRWA demand values with each of the four supply conditions present in projected intervals when additional capacity must be on-line to meet projected increased demand.

## 5.2 CRWA Future Development Assumptions

### Supplies

The CRWA member WSCs currently obtain water by one or more of the following methods:

- self-supplied groundwater,
- purchased groundwater; and/or,
- purchased surface water.

Self-supplied groundwater refers water obtained from wells owned and maintained by an individual WSC. Purchased groundwater refers to water obtained through an interconnect to a neighboring groundwater supplier. Purchased surface water refers to water obtained through an interconnect to treated surface water from a neighboring utility or the utility's ability to obtain untreated surface water from a wholesale supplier (i.e., Guadalupe-Blanco River Authority). Green Valley WSC obtains its water supply through self-supplied and purchased groundwater. Springs Hill WSC obtains its water supply through purchased surface and groundwater. Crystal Clear WSC obtains its water supply solely through self-supplied groundwater; while, East Central WSC obtains its total water supply through purchased groundwater from the of SACWB.

### 5.2.1 Green Valley Water Supply Corporation

Green Valley WSC obtains its water supply through self-supplied and purchased groundwater. Green Valley WSC owns and operates two wells in eastern Comal County. These wells are drilled into the Edwards Aquifer and are approximately 250 feet deep. The amount of water which GVWSC may remove from the Edwards Aquifer is controlled by the EUWD through a "Permit to Transport Water From The Edwards Underground Water District". Green Valley WSC currently holds a permit from the EUWD to transport 2,103 AF/yr (1.87 MGD) from the Edwards Aquifer to serve GVWSC customers. Green Valley WSC is grandfathered for an additional 1,105 AF/yr (0.98 MGD). The current EUWD diversion permit expires in February, 1995. Combining permitted and grandfathered withdrawal rates, GVWSC's current

total self-supplied groundwater withdrawal capacity is approximately 3,208 AF/yr (2.86 MGD). Green Valley WSC self-supplied groundwater usage for 1988 was approximately 1,495 AF (487 MG).

Purchased groundwater is made available through an interconnect agreement with NBU. The maximum capacity of the interconnect is 1,776 AF/yr (1.58 MGD). This connection is intended to serve GVWSC'S Plant No. 2 and the areas adjacent to the Guadalupe River. The agreement is renewable on an annual basis subject to mutual consent of both parties. Green Valley WSC purchased groundwater usage for 1988 amounted to approximately 488 AF (159 MG).

#### 5.2.2 Springs Hill Water Supply Corporation

Springs Hill WSC provides service to its customers through purchased surface and groundwater. Springs Hill WSC owns and maintains a 1,770 AF/yr (1.5 MGD) surface water treatment plant located near Seguin. Raw water is diverted from the Guadalupe River, treated at the SHWSC plant, and distributed through the SHWSC system. Springs Hill WSC, by agreement with the GBRA, may divert up to 1,500 AF/yr from the Guadalupe River. This agreement with the Guadalupe-Blanco River Authority (GBRA) apparently extends in perpetuity. In addition, SHWSC maintains an emergency interconnect with the City of Seguin. In 1988, SHWSC purchased approximately 913 AF (297.5 MG) from GBRA and approximately 2.74 AF (892.8 MG) from the City of Seguin.

In addition to the surface water supply, Springs Hill obtains service from NBU through an interconnect agreement. New Braunfels Utilities provides service to approximately 1,030 connections in the northern portion of the SHWSC service area, along State Hwy 46. Based on an average daily demand of 0.6 gpm/connection, this interconnect is capable of supplying up to 998 AF/yr (0.89 MGD) to Springs Hill. The interconnect agreement between NBU and SHWSC is renewable, with the consent of both parties. Total groundwater purchased by SHWSC in 1988 amounted to approximately 569 AF (185.4 MG).

#### 5.2.3 Crystal Clear Water Supply Corporation

Crystal Clear WSC obtains its water solely through self-supplied groundwater sources. Crystal Clear WSC owns and operates six wells, two in Comal County and four in Hays County. As with GVWSC, the EUWD controls the amount of water which CCWSC may pump from the Edwards Aquifer. In May 1985, CCWSC requested that its 1965 permitted withdrawal rate of 552 AF/yr (0.49 MGD) be increased to 1,202 AF/yr (1.07 MGD). In 1988, CCWSC pumped approximately 1,123 AF (366 MG) from the Edwards Aquifer. Crystal Clear WSC's permit with the EUWD expires in May of 1995.

#### 5.2.4 East Central Water Supply Corporation

East Central WSC procures all of its water from the SACWB. The purchase agreement states that the SACWB will provide ECWSC with a maximum of 2,245 AF/yr (2.00 MGD) of water through 2007; however,

each party has the option to extend the agreement to January, 2018. The original agreement provides that the SACWB shall be the sole source of water supply to ECWSC. An amendment to the agreement modified the sole source requirement to allow for an alternate supply source. That supply source must, however, be a surface water source. Furthermore, the alternate source may only serve that portion of ECWSC which lies outside of Bexar County (the northeastern portion of ECWSC). In 1988, ECWSC purchased approximately 1,335 AF (435 MG) of groundwater from SACWB.

### **5.3 Projected Demands**

Projected water demands for the CRWA study area have been developed from Texas Water Development Board (TWDB) data and are presented in full in Chapter 3 of this study. The High Population Series/High Per Capita Use Rate/With Water Conservation future water demand estimates were used to project future demands. A summary of these projected demands is presented in Table 5-2 for the individual CRWA members and the CRWA as a whole.

The most significant future increase demand occurs within the first five-year planning period (1990 to 1995). Demand for the total CRWA study area is projected to increase by approximately 18 percent over this period. The demand projection for the second five-year planning period (1995 to 2000) shows a growth of 14 percent above the previous period. Although demand continues to increase for the duration of the overall planning period, the rate of increase continues to diminish until when in the final five-year study period, demand has increased by only 4-1/2 percent over the prior five-year period. Annual water demand for 1990 is projected to be approximately 6,300 AF. Annual water demand for 2020 is projected to be approximately 11,400 AF. Over the duration of the planning period, the system is projected to require an increase in supply capacity of approximately 5,100 AF/yr or 4.55 MGD.

Best case, probable case, worst case and drought supply/demand comparisons were conducted for each of the CRWA member utilities. The results are presented in the following sections.

#### **5.3.1 Green Valley Water Supply Corporation**

The best case supply scenario assumes that both permitted and grandfathered withdrawal rates from the EUWD would continue through the duration of the planning period. The interconnect with NBU is assumed to continue through 1994 but would be discontinued prior to 1995. The results of this comparison indicate that supply will exceed demand through 2005. However, between 2005 and 2010, GVWSC will develop a supply deficit of approximately 82 AF/yr (0.07 MGD). Table 5-3 summarizes the data used for the GVWSC best case supply scenario.

The probable case supply scenario assumes that the existing permitted withdrawal rate from the EUWD would continue through 2004, but would be discontinued after a one-time, ten-year extension of the

Table 5-2  
 Projected Supply Demand Summary  
 Canyon Regional Water Authority

Year	Green Valley WSC		Springs Hill WSC		Crystal Clear WSC		East Central WSC		Canyon Regional Water Authority		% Increase From Previous 5 Yr. Planning Period
	Demand (AF/yr)	Demand (MGD)	Demand (AF/yr)	Demand (MGD)	Demand (AF/yr)	Demand (MGD)	Demand (AF/yr)	Demand (MGD)	Demand (AF/yr)	Demand (MGD)	
1990	1,995	1.78	1,519	1.36	1,363	1.22	1,430	1.28	6,307	5.63	N/A
1995	2,355	2.10	1,792	1.60	1,609	1.44	1,687	1.51	7,443	6.64	18.01%
2000	2,692	2.40	2,049	1.83	1,839	1.64	1,929	1.72	8,509	7.60	14.32%
2005	3,001	2.68	2,285	2.04	2,051	1.83	2,150	1.92	9,487	8.47	11.49%
2010	3,289	2.94	2,503	2.23	2,247	2.01	2,356	2.10	10,395	9.28	9.57%
2015	3,453	3.08	2,629	2.35	2,360	2.11	2,474	2.21	10,916	9.74	5.01%
2020	3,608	3.22	2,747	2.45	2,465	2.20	2,585	2.31	11,405	10.18	4.48%

Table 5-3  
Best Case Supply Option Projection  
Green Valley Water Supply Corporation

Year	Demand (AF/yr)	Demand (GPM)	Permitted Withdrawal EUWD (GPM) a/	Grandfathered Withdrawal From EUWD (GPM) b/	Interconnect With NBU (GPM) c/	Supply Deficit/Surplus (GPM)	Supply Deficit/Surplus (MGD)	Supply Deficit/Surplus (AF/yr)
1990	1,995	1,237	1,303	685	1,100	1,851	2.67	2,986
1995	2,355	1,460	1,303	685	0	528	0.76	852
2000	2,692	1,669	1,303	685	0	319	0.46	515
2005	3,001	1,860	1,303	685	0	128	0.18	206
2010	3,289	2,039	1,303	685	0	-51	-0.07	-82
2015	3,453	2,141	1,303	685	0	-153	-0.22	-246
2020	3,608	2,237	1,303	685	0	-249	-0.36	-401

- a/ Assumes that existing permit with EUWD will be extended through 2020, at current permitted pumping rate.  
b/ Assumes grandfathered water from EUWD is supplied in perpetuity.  
c/ Assumes 1,100 GPM Interconnect with New Braunfels Utilities is terminated prior to beginning of 1995.

Table 5-4  
Probable Case Supply Option Projection  
Green Valley Water Supply Corporation

Year	Demand (AF/yr)	Demand (GPM)	Permitted Withdrawal EUWD (GPM) a/	Grandfathered Withdrawal From EUWD (GPM) b/	Interconnect With NBU (GPM) c/	Supply Deficit/Surplus (GPM)	Supply Deficit/Surplus (MGD)	Supply Deficit/Surplus (AF/yr)
1990	1,995	1,237	1,303	685	1,100	1,851	2.67	2,986
1995	2,355	1,460	1,303	685	0	528	0.76	852
2000	2,692	1,669	1,303	685	0	319	0.46	515
2005	3,001	1,860	0	685	0	-1,175	-1.69	-1,896
2010	3,289	2,039	0	685	0	-1,354	-1.95	-2,184
2015	3,453	2,141	0	685	0	-1,456	-2.10	-2,348
2020	3,608	2,237	0	685	0	-1,552	-2.23	-2,503

- a/ Assumes a one-time extension of 10 years for existing EUWD permit, at current permitted withdrawal rate.  
b/ Assumes grandfathered water from EUWD is supplied in perpetuity.  
c/ Assumes 1,100 GPM Interconnect with New Braunfels Utilities is terminated prior to beginning of 1995.

Table 5-5  
Worst Case Supply Option Projection  
Green Valley Water Supply Corporation

Year	Demand (AF/yr)	Demand (GPM)	Permitted Withdrawal EUWD (GPM) a/	Grandfathered Withdrawal From EUWD (GPM) b/	Interconnect With NBU (GPM) c/	Supply Deficit/Surplus (GPM)	Supply Deficit/Surplus (MGD)	Supply Deficit/Surplus (AF/yr)
1990	1,995	1,237	1,303	685	1,100	1,851	2.67	2,986
1995	2,355	1,460	0	685	0	-775	-1.12	-1,250
2000	2,692	1,669	0	685	0	-984	-1.42	-1,587
2005	3,001	1,860	0	685	0	-1,175	-1.69	-1,896
2010	3,289	2,039	0	685	0	-1,354	-1.95	-2,184
2015	3,453	2,141	0	685	0	-1,456	-2.10	-2,348
2020	3,608	2,237	0	685	0	-1,552	-2.23	-2,503

- a/ Assumes existing permit with EUWD expires in 1995 and is not renewed.  
b/ Assume grandfathered water from Edwards District is supplied in perpetuity.  
c/ Assumes 1,100 GPM Interconnect with New Braunfels Utilities is terminated prior to beginning of 1995.

Table 5-6  
Drought Condition Supply Option Projection  
Green Valley Water Supply Corporation

Year	Demand (AF/yr)	Demand (GPM)	Permitted Withdrawal EUWD (GPM) a/ b/ c/	Grandfathered Withdrawal From EUWD (GPM) d/	Interconnect With NBU (GPM) e/	Supply Deficit/Surplus (GPM)	Supply Deficit/Surplus (MGD)	Supply Deficit/Surplus (AF/yr)
1990	1,995	1,237	583	480	72	-102	-0.15	-164
1995	2,355	1,460	0	480	0	-980	-1.41	-1,581
2000	2,692	1,669	0	480	0	-1,189	-1.71	-1,918
2005	3,001	1,860	0	480	0	-1,380	-1.99	-2,227
2010	3,289	2,039	0	480	0	-1,559	-2.24	-2,515
2015	3,453	2,141	0	480	0	-1,661	-2.39	-2,679
2020	3,608	2,237	0	480	0	-1,757	-2.53	-2,834

- a/ Assumes drought management plan in effect. Drought management plan restricts allowable withdrawals from EUWD to 70% of 1984 pumpage.  
b/ Total 1984 pumpage from EUWD was 1,343.3 AF. Allowable drought condition pumpage is 940 AF/yr (583 GPM).  
c/ Assumes existing permit with EUWD expires in 1995 and is not renewed.  
d/ Assume grandfathered water from Edwards District (685 GPM) is supplied in perpetuity but is reduced by 30 percent due to drought management restrictions.  
e/ Assumes that under the EUWD Drought Management Plan, the amount of water available for purchase will be equal to 70% of the amount purchased in 1984. Green Valley WSC purchased 166.3 AF (103 GPM) of water from NBU in 1984. Seventy percent of that value is 72 GPM.

current permit. Grandfathered withdrawal rates were assumed to continue through the duration of the planning period. The interconnect with NBU was assumed to terminate prior to the beginning of 1995. This scenario predicts that a supply deficit will occur between 2000 and 2005. The projected deficit would result from the discontinuation of the current 2,103 AF/yr (1.88 MGD) permitted withdrawal from the EUWD. The demand projection for 2000 shows a surplus in supply of approximately 515 AF/yr (0.46 MGD), while the demand projection for 2005 shows a deficit in supply of approximately 1,896 AF/yr (1.69 MGD). Table 5-4 summarizes the data used for the GVWSC probable case supply scenario.

The worst case supply scenario assumed that permitted withdrawals from the EUWD would be discontinued at the end of their current permit period. Grandfathered withdrawals from the EUWD would continue for the duration of the planning period. The interconnect with NBU was assumed to terminate prior to the beginning of 1995. The results of this comparison indicate an immediate deficit in supply beginning in 1995. Using this scenario, GVWSC would experience a 2,986 AF/yr (2.66 MGD) surplus in 1990 while having a 1,250 AF/yr (1.12 MGD) deficit by 1995. Table 5-5 summarizes the data used for the GVWSC worst case supply scenario.

The drought condition supply scenario assumes worst case supply conditions with self-supplied groundwater availability equal to 70 percent of GVWSC's annual pumpage for 1984. Texas Water Development Board records show a total pumpage of 1,343.3 AF for 1984. Application of a 30 percent reduction factor to the 1984 total pumpage results in an allowable annual pumpage of 940 AF/yr (0.84 MGD), under Stage IV conditions. In addition to the reduction in allowable pumpage, the drought condition supply scenario assumes that the existing permit to pump from the EUWD expires prior to 1995 and that the interconnect agreement with NBU expires prior to 1995. Under this condition, a supply surplus of 1,825 AF/yr (1.63 MGD) is projected for 1990 with a deficit of 1,250 AF/yr (1.12 MGD) projected to occur in 1995. Table 5-6 summarizes the data used for the GVWSC drought case supply scenario.

### 5.3.2 Springs Hill Water Supply Corporation

Springs Hill WSC is unaffected by any of the "case" comparisons; thus results are the same for all four case comparisons. Springs Hill WSC currently is allowed to divert surface water from the Guadalupe Blanco River Authority (GBRA) in the amount of 1,500 AF/yr (1.34 MGD). Each of the four case comparisons assumed that 1,500 AF/yr would be available from the GBRA for the duration of the planning period. In addition to the GBRA supply, SHWSC buys water from NBU through an interconnect agreement, servicing approximately 1,030 connections in the SHWSC service area. Assuming an average daily supply of 0.6 gpm/connection to this area, NBU could provide as much as 997 AF/yr (0.89 MGD) of water a year to Springs Hill. The terms of this contract allow for an initial ten-year duration with provision for three consecutive ten-year extensions. Thus, it is assumed that New Braunfels Utilities will provide approximately 997 AF/yr (0.89 MGD) to SHWSC above the 1,500 AF/yr (1.34 MGD) that SHWSC obtains

from the GBRA. Based on these assumptions, supply and demand relationships remain the same for each of the four case scenarios. Demand is projected to exceed supply by the year 2010, when SHWSC will experience a supply deficit of approximately 6 AF/yr (0.005 MGD). Table 5-7, through Table 5-10 summarize the data used for the SHWSC supply scenarios. Springs Hill WSC is unaffected by the drought condition supply scenario since SHWSC is not a self-producing groundwater purveyor.

### 5.3.3 Crystal Clear Water Supply Corporation

Crystal Clear Water Supply Corporation obtains its entire water supply from six wells drilled into the Edwards Aquifer. CCWSC is permitted by the EUWD to withdraw approximately 1,202 AF/yr (1.07 MGD) from the Edwards Aquifer. The case scenarios for CCWSC are dependent solely on whether and when the EUWD discontinues permitting withdrawal from the Edwards Aquifer. Under the best case scenario, CCWSC would continue withdrawals from the EUWD for the duration of the planning period. Best case is a misnomer in this instance since, based on projected water demands, and TWDB groundwater use data, CCWSC will experience a deficit in supply in 1990. The deficit in 1990 is projected to be approximately 161 AF/yr (0.14 MGD). The best case scenario minimize the incremental increase of the deficit for the duration of the planning period, when compared to the probable case scenarios. Table 5-11 summarizes the data used for the CCWSC best case supply scenario.

The probable case scenario assumed that, after the existing permit with the EUWD expires in 1995, the EUWD would allow a one-time, ten-year permit extension, at current permitted withdrawal rates. Based on the probable case scenario, CCWSC still experiences a deficit beginning in 1990. However, when the EUWD groundwater source is discontinued in 2005, CCWSC experiences a dramatic increase in their supply deficit. In 2000, the deficit is projected to be approximately 637-AF/yr (0.57 MGD), while in 2005, the deficit is projected to be approximately 2,050 AF/yr (1.83 MGD). Table 5-12 summarizes the data used for the CCWSC probable case supply scenario.

The worst case scenario assumed that groundwater supplies would be discontinued prior to the beginning of 1995. Thus, the supply deficit increases from 161 AF/yr (0.14 MGD) in 1990, to approximately 1,609 AF/yr (1.45 MGD) in 1995. However, as in the best case scenario, the worst case scenario minimizes the incremental deficit for the duration of the planning period, after the initial increase between 1990 and 1995. Table 5-13 summarizes the data used for the Crystal Clear worst case supply scenario.

The drought condition supply scenario assumes worst case supply conditions with self-supplied groundwater availability equal to 70 percent of CCWSC's annual pumpage for 1984. Texas Water Development Board records show a total pumpage of 790.1 AF for 1984. Application of a 30 percent reduction factor to the 1984 total pumpage results in an allowable annual pumpage of 553 AF/yr (0.49



Table 5-7  
Best Case Supply Option Projection  
Springs Hill Water Supply Corporation

Year	Demand (AF/yr)	Demand (GPM)	Permitted Diversion Rate From GBRA (GPM) a/	Interconnect With NBU (GPM) b/	Supply Deficit/Surplus (GPM)	Supply Deficit/Surplus (MGD)	Supply Deficit/Surplus (AF/yr)
1990	1,519	942	930	618	606	0.87	978
1995	1,792	1,111	930	618	437	0.63	705
2000	2,049	1,270	930	618	278	0.40	448
2005	2,285	1,417	930	618	131	0.19	212
2010	2,503	1,552	930	618	-4	-0.01	-6
2015	2,629	1,630	930	618	-82	-0.12	-132
2020	2,747	1,703	930	0	-773	-1.11	-1,247

a/ Assumes firm diversion rate of 1,500 AF/yr (1.34 MGD) is available through 2020.

b/ Assumes that existing interconnect with New Braunfels is extended through 2019 but expires prior to beginning of 2020.

Table 5-8  
Probable Case Supply Option Projection  
Springs Hill Water Supply Corporation

Year	Demand (AF/yr)	Demand (GPM)	Permitted Diversion Rate From GBRA (GPM) a/	Interconnect With NBU (GPM) b/	Supply Deficit/Surplus (GPM)	Supply Deficit/Surplus (MGD)	Supply Deficit/Surplus (AF/yr)
1990	1,519	942	930	618	606	0.87	978
1995	1,792	1,111	930	618	437	0.63	705
2000	2,049	1,270	930	618	278	0.40	448
2005	2,285	1,417	930	618	131	0.19	212
2010	2,503	1,552	930	618	-4	-0.01	-6
2015	2,629	1,630	930	618	-82	-0.12	-132
2020	2,747	1,703	930	0	-773	-1.11	-1,247

a/ Assumes firm diversion rate of 1,500 AF/yr (1.34 MGD) is available through 2020.

b/ Assumes that existing interconnect with New Braunfels is extended through 2019 but expires prior to beginning of 2020.

Table 5-9  
Worst Case Supply Option Projection  
Springs Hill Water Supply Corporation

Year	Demand (AF/yr)	Demand (GPM)	Permitted Diversion Rate From GBRA (GPM) a/	Interconnect With NBU (GPM) b/	Supply Deficit/Surplus (GPM)	Supply Deficit/Surplus (MGD)	Supply Deficit/Surplus (AF/yr)
1990	1,519	942	930	618	606	0.87	978
1995	1,792	1,111	930	618	437	0.63	705
2000	2,049	1,270	930	618	278	0.40	448
2005	2,285	1,417	930	618	131	0.19	212
2010	2,503	1,552	930	618	-4	-0.01	-6
2015	2,629	1,630	930	618	-82	-0.12	-132
2020	2,747	1,703	930	0	-773	-1.11	-1,247

a/ Assumes firm diversion rate of 1,500 AF/yr (1.34 MGD) is available through 2020.

b/ Assumes that existing interconnect with New Braunfels is extended through 2019 but expires prior to beginning of 2020.

Table 5-10  
Drought Condition Supply Option Projection  
Springs Hill Water Supply Corporation

Year	Demand (AF/yr)	Demand (GPM)	Permitted Diversion Rate From GBRA (GPM) a/	Interconnect With NBU (GPM) b/ c/	Supply Deficit/Surplus (GPM)	Supply Deficit/Surplus (MGD)	Supply Deficit/Surplus (AF/yr)
1990	1,519	942	930	178	166	0.24	268
1995	1,792	1,111	930	178	-3	0.00	-5
2000	2,049	1,270	930	178	-162	-0.23	-262
2005	2,285	1,417	930	178	-309	-0.44	-498
2010	2,503	1,552	930	178	-444	-0.64	-716
2015	2,629	1,630	930	178	-522	-0.75	-842
2020	2,747	1,703	930	0	-773	-1.11	-1,247

a/ Assumes firm diversion rate of 1,500 AF/yr (1.34 MGD) is available through 2020.

b/ Assumes that existing interconnect with New Braunfels is extended through 2019 but expires prior to beginning of 2020.

c/ Assumes that under the EUWD Drought Management Plan, the amount of water available for purchase will be equal to 70% of the amount purchased in 1984. Springs Hill WSC purchased 411.9 AF (255 GPM) of water from NBU in 1984. Seventy percent of that value is 178 GPM.

**Table 5-11**  
Best Case Supply Option Projection  
Crystal Clear Water Supply Corporation

Year	Demand (AF/yr)	Demand (GPM)	Permitted Withdrawal From EUWD (GPM) a/	Supply Deficit/Surplus (GPM)	Supply Deficit/Surplus (MGD)	Supply Deficit/Surplus (AF/yr)
1990	1,363	845	745	-100	-0.14	-161
1995	1,609	997	745	-252	-0.36	-407
2000	1,839	1,140	745	-395	-0.57	-637
2005	2,051	1,271	745	-526	-0.76	-849
2010	2,247	1,393	745	-648	-0.93	-1,045
2015	2,360	1,463	745	-718	-1.03	-1,158
2020	2,465	1,528	745	-783	-1.13	-1,263

a/ Assumes that existing permit with the EUWD will be extended at current pumping rate through 2020.

**Table 5-12**  
Probable Case Supply Option Projection  
Crystal Clear Water Supply Corporation

Year	Demand (AF/yr)	Demand (GPM)	Permitted Withdrawal From EUWD (GPM) a/	Supply Deficit/Surplus (GPM)	Supply Deficit/Surplus (MGD)	Supply Deficit/Surplus (AF/yr)
1990	1,363	845	745	-100	-0.14	-161
1995	1,609	997	745	-252	-0.36	-407
2000	1,839	1,140	745	-395	-0.57	-637
2005	2,051	1,271	0	-1,271	-1.83	-2,051
2010	2,247	1,393	0	-1,393	-2.01	-2,247
2015	2,360	1,463	0	-1,463	-2.11	-2,360
2020	2,465	1,528	0	-1,528	-2.20	-2,465

a/ Assumes a one-time, 10-year extension of existing permit with EUWD through 2004 for existing permitted withdrawal rate.

**Table 5-13**  
Worst Case Supply Options Projection  
Crystal Clear Water Supply Corporation

Year	Demand (AF/yr)	Demand (GPM)	Permitted Withdrawal From EUWD (GPM) a/	Supply Deficit/Surplus (GPM)	Supply Deficit/Surplus (MGD)	Supply Deficit/Surplus (AF/yr)
1990	1,363	845	745	-100	-0.14	-161
1995	1,609	997	0	-997	-1.44	-1,609
2000	1,839	1,140	0	-1,140	-1.64	-1,839
2005	2,051	1,271	0	-1,271	-1.83	-2,051
2010	2,247	1,393	0	-1,393	-2.01	-2,247
2015	2,360	1,463	0	-1,463	-2.11	-2,360
2020	2,465	1,528	0	-1,528	-2.20	-2,465

a/ Assumes existing permit with EUWD expires in 1995 and is not renewed.

**Table 5-14**  
Drought Condition Supply Option Projection  
Crystal Clear Water Supply Corporation

Year	Demand (AF/yr)	Demand (GPM)	Permitted Withdrawal From EUWD (GPM) a/ b/ c/	Supply Deficit/Surplus (GPM)	Supply Deficit/Surplus (MGD)	Supply Deficit/Surplus (AF/yr)
1990	1,363	845	343	-502	-0.72	-810
1995	1,609	997	0	-997	-1.44	-1,609
2000	1,839	1,140	0	-1,140	-1.64	-1,839
2005	2,051	1,271	0	-1,271	-1.83	-2,051
2010	2,247	1,393	0	-1,393	-2.01	-2,247
2015	2,360	1,463	0	-1,463	-2.11	-2,360
2020	2,465	1,528	0	-1,528	-2.20	-2,465

a/ Assumes drought management plan in effect. Drought management plan restricts allowable withdrawals from EUWD to 70% of 1984 pumpage.

b/ Total 1984 pumpage from EUWD was 790.1 AF. Allowable drought condition pumpage is 553.07 AF/yr (343 GPM).

c/ Assumes existing permit with EUWD expires in 1995 and is not renewed.

MGD), under Stage IV conditions. In addition to the reduction in allowable pumpage, the drought condition supply scenario assumes that the existing permit to pump from the EUWD expires prior to 1995. Under this condition, a supply deficit of 810 AF/yr (0.72 MGD) is projected to occur in 1990. Table 5-14 summarizes the data used for the Crystal Clear drought case supply scenario.

#### 5.3.4 East Central Water Supply Corporation

East Central Water Supply Corporation obtains its entire water source from the SACWB. Their interconnect agreement extends to February 2017. The SACWB interconnect agreement with ECWSC provides for a maximum transfer rate of 2,245 AF/yr (2.00 MGD). Under all three case scenarios, ECWSC is projected to experience its first supply deficit between 2005 and 2010. The most drastic supply deficit will occur between 2015 and 2020 when the interconnect agreement with the SACWB expires. The projected deficit for 2020 is 2,585 AF/yr (2.301 MGD). This is the largest incremental increase in supply deficit projected to be experienced by any of the individual CRWA members. Tables 5-15 through 5-18 summarize the data used for the ECWSC supply scenarios. East Central WSC is unaffected by the drought condition supply scenario since SHWSC is not a self-producing groundwater purveyor.

#### 5.3.5 Canyon Regional Water Authority

Combining the results of the best case scenario, the CRWA, as a whole, is projected to experience a supply deficit of 336 AF/yr (0.30 MGD) by 2005. Under the probable case scenario, a supply deficit of 3,629 AF/yr (3.24 MGD) is projected to occur by 2005. The worst case scenario projects that a supply deficit of 1,602 AF/Y (1.43 MGD) will occur by 1995. The drought condition supply scenario projects that a supply deficit of 1,602 AF/yr (1.43 MGD) will occur by 1995. The maximum deficit projected under the best case scenario is 5,500 AF/yr (4 .91 MGD) by 2020. The probable case and worst case scenarios project a maximum supply deficit of 8,792 AF/yr (7.85 MGD) by 2020. The maximum deficit projected for the drought condition supply scenario is 8,792 AF/yr (7.85 MGD) and occurs in 2020. Tables 5-19, through 5-22 and Figures 5-1 through 5-9 summarize the data used for the CRWA supply scenarios.

Table 5-15  
Best Case Supply Option Projection  
East Central Water Supply Corporation

Year	Demand (AF/yr)	Demand (GPM)	Interconnect With SACWB (GPM) a/	Supply Deficit/Surplus (GPM)	Supply Deficit/Surplus (MGD)	Supply Deficit/Surplus (AF/yr)
1990	1,430	886	1,392	506	0.73	815
1995	1,687	1,046	1,392	346	0.50	558
2000	1,929	1,196	1,392	196	0.28	316
2005	2,150	1,333	1,392	59	0.09	95
2010	2,356	1,461	1,392	-69	-0.10	-111
2015	2,474	1,534	1,392	-142	-0.20	-229
2020	2,585	1,602	0	-1,602	-2.31	-2,585

a/ Assumes that East Central will continue receiving water from SACWB through 2017.

Table 5-16  
Probable Case Supply Option Projection  
East Central Water Supply Corporation

Year	Demand (AF/yr)	Demand (GPM)	Interconnect With SACWB (GPM) a/	Supply Deficit/Surplus (GPM)	Supply Deficit/Surplus (MGD)	Supply Deficit/Surplus (AF/yr)
1990	1,430	886	1,392	506	0.73	815
1995	1,687	1,046	1,392	346	0.50	558
2000	1,929	1,196	1,392	196	0.28	316
2005	2,150	1,333	1,392	59	0.09	95
2010	2,356	1,461	1,392	-69	-0.10	-111
2015	2,474	1,534	1,392	-142	-0.20	-229
2020	2,585	1,602	0	-1,602	-2.31	-2,585

a/ Assumes that East central will continue to receive water from SACWB through 2017.

Table 5-17  
Worst Case Supply Option Projection  
East Central Water Supply Corporation

Year	Demand (AF/yr)	Demand (GPM)	Interconnect With SACWB (GPM) a/	Supply Deficit/Surplus (GPM)	Supply Deficit/Surplus (MGD)	Supply Deficit/Surplus (AF/yr)
1990	1,430	886	1,392	506	0.73	815
1995	1,687	1,046	1,392	346	0.50	558
2000	1,929	1,196	1,392	196	0.28	316
2005	2,150	1,333	1,392	59	0.09	95
2010	2,356	1,461	1,392	-69	-0.10	-111
2015	2,474	1,534	1,392	-142	-0.20	-229
2020	2,585	1,602	0	-1,602	-2.31	-2,585

(a) Assumes that East Central will continue receiving water from SACWB through 2017.

Table 5-18  
Drought Condition Supply Option Projection  
East Central Water Supply Corporation

Year	Demand (AF/yr)	Demand (GPM)	Interconnect With SACWB (GPM) a/ b/	Supply Deficit/Surplus (GPM)	Supply Deficit/Surplus (MGD)	Supply Deficit/Surplus (AF/yr)
1990	1,430	886	491	-395	-0.57	-638
1995	1,687	1,046	491	-555	-0.80	-895
2000	1,929	1,196	491	-705	-1.01	-1,137
2005	2,150	1,333	491	-842	-1.21	-1,358
2010	2,356	1,461	491	-970	-1.40	-1,564
2015	2,474	1,534	491	-1,043	-1.50	-1,682
2020	2,585	1,602	0	-1,602	-2.31	-2,585

a/ Assumes that East Central will continue receiving water from SACWB through 2017.

b/ Assumes that under the EUWD Drought Management Plan, the amount of water available for purchase will be equal to 70% of the amount purchased in 1984. East Central WSC purchased 1,003.5 AF (622 GPM) of water from SACWB in 1984. Seventy percent of that value is 491 GPM.

Table 5-19  
Best Case Supply Option Projection  
Canyon Regional Water Authority

Year	System Supply Deficit/Surplus				
	Green Valley WSC (MGD) a/	Springs Hill WSC (MGD) b/	Crystal Clear WSC (MGD) c/	East Central WSC (MGD) d/	CRWA Total (MGD)
1990	2.67	0.87	-0.14	0.73	4.13
1995	0.76	0.63	-0.36	0.50	1.53
2000	0.46	0.40	-0.57	0.28	0.57
2005	0.18	0.19	-0.76	0.09	-0.30
2010	-0.07	-0.01	-0.93	-0.10	-1.11
2015	-0.22	-0.12	-1.03	-0.20	-1.57
2020	-0.36	-1.11	-1.13	-2.31	-4.91

- a/ Taken from Table 5-3.  
b/ Taken from Table 5-7.  
c/ Taken from Table 5-11.  
d/ Taken from Table 5-15.

Table 5-20  
Probable Case Supply Option Projection  
Canyon Regional Water Authority

Year	System Supply Deficit/Surplus				
	Green Valley WSC (MGD) a/	Springs Hill WSC (MGD) b/	Crystal Clear WSC (MGD) c/	East Central WSC (MGD) d/	CRWA Total (MGD)
1990	2.67	0.87	-0.14	0.73	4.13
1995	0.76	0.63	-0.36	0.50	1.53
2000	0.46	0.40	-0.57	0.28	0.57
2005	-1.89	0.19	-1.83	0.09	-3.24
2010	-1.95	-0.01	-2.01	-0.10	-4.07
2015	-2.10	-0.12	-2.11	-0.20	-4.53
2020	-2.23	-1.11	-2.20	-2.31	-7.85

- a/ Taken from Table 5-4.  
b/ Taken from Table 5-8.  
c/ Taken from Table 5-12.  
d/ Taken from Table 5-16.

Table 5-21  
Worst Case Supply Option Projection  
Canyon Regional Water Authority

Year	System Supply Deficit/Surplus				
	Green Valley WSC (MGD) a/	Springs Hill WSC (MGD) b/	Crystal Clear WSC (MGD) c/	East Central WSC (MGD) d/	CRWA Total (MGD)
1990	2.67	0.87	-0.14	0.73	4.13
1995	-1.12	0.63	-1.44	0.50	-1.43
2000	-1.42	0.40	-1.64	0.28	-2.38
2005	-1.69	0.19	-1.83	0.09	-3.24
2010	-1.95	-0.01	-2.01	-0.10	-4.07
2015	-2.10	-0.12	-2.11	-0.20	-4.53
2020	-2.23	-1.11	-2.20	-2.31	-7.85

- a/ Taken from Table 5-5.  
b/ Taken from Table 5-9.  
c/ Taken from Table 5-13.  
d/ Taken from Table 5-17.

Table 5-22  
Drought Condition Supply Option Projection  
Canyon Regional Water Authority

Year	System Supply Deficit/Surplus				
	Green Valley WSC (MGD) a/	Springs Hill WSC (MGD) b/	Crystal Clear WSC (MGD) c/	East Central WSC (MGD) d/	CRWA Total (MGD)
1990	-0.15	0.24	-0.72	-0.57	-1.20
1995	-1.41	0.00	-1.44	-0.80	-3.65
2000	-1.70	-0.23	-1.64	-1.01	-4.58
2005	-1.99	-0.44	-1.83	-1.21	-5.47
2010	-2.24	-0.64	-2.01	-1.40	-6.29
2015	-2.39	-0.75	-2.11	-1.50	-6.75
2020	-2.53	-1.11	-2.20	-2.31	-8.15

- a/ Taken from Table 5-6.  
b/ Taken from Table 5-10.  
c/ Taken from Table 5-14.  
d/ Taken from Table 5-18.

**Figure 5-1**  
**Best Case Projected CRWA Member**  
**Future Water Demand and Supplies**

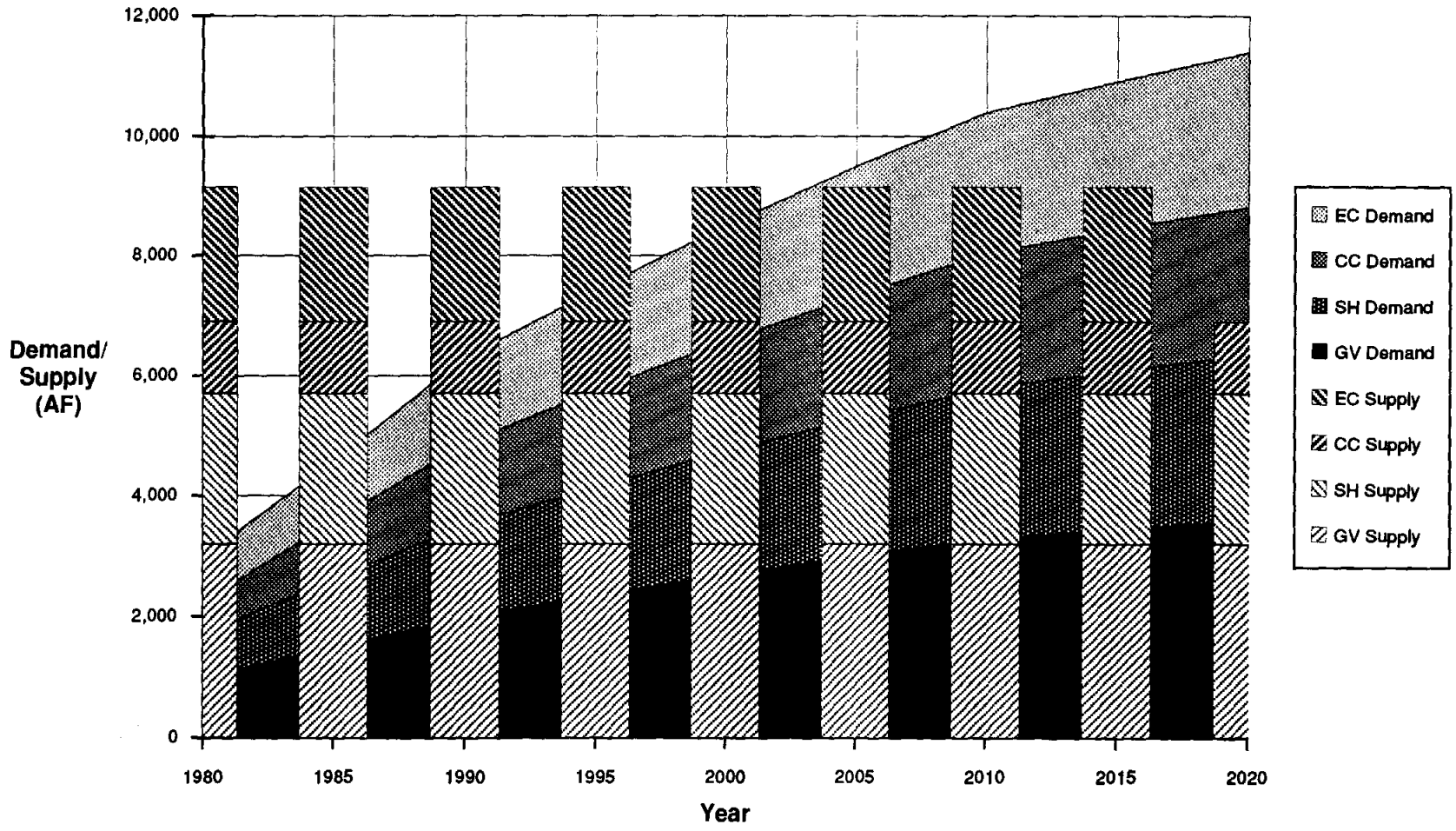

Figure 5-2  
Best Case Projected CRWA Member Future Water  
Demand and Required Supplemental Supplies

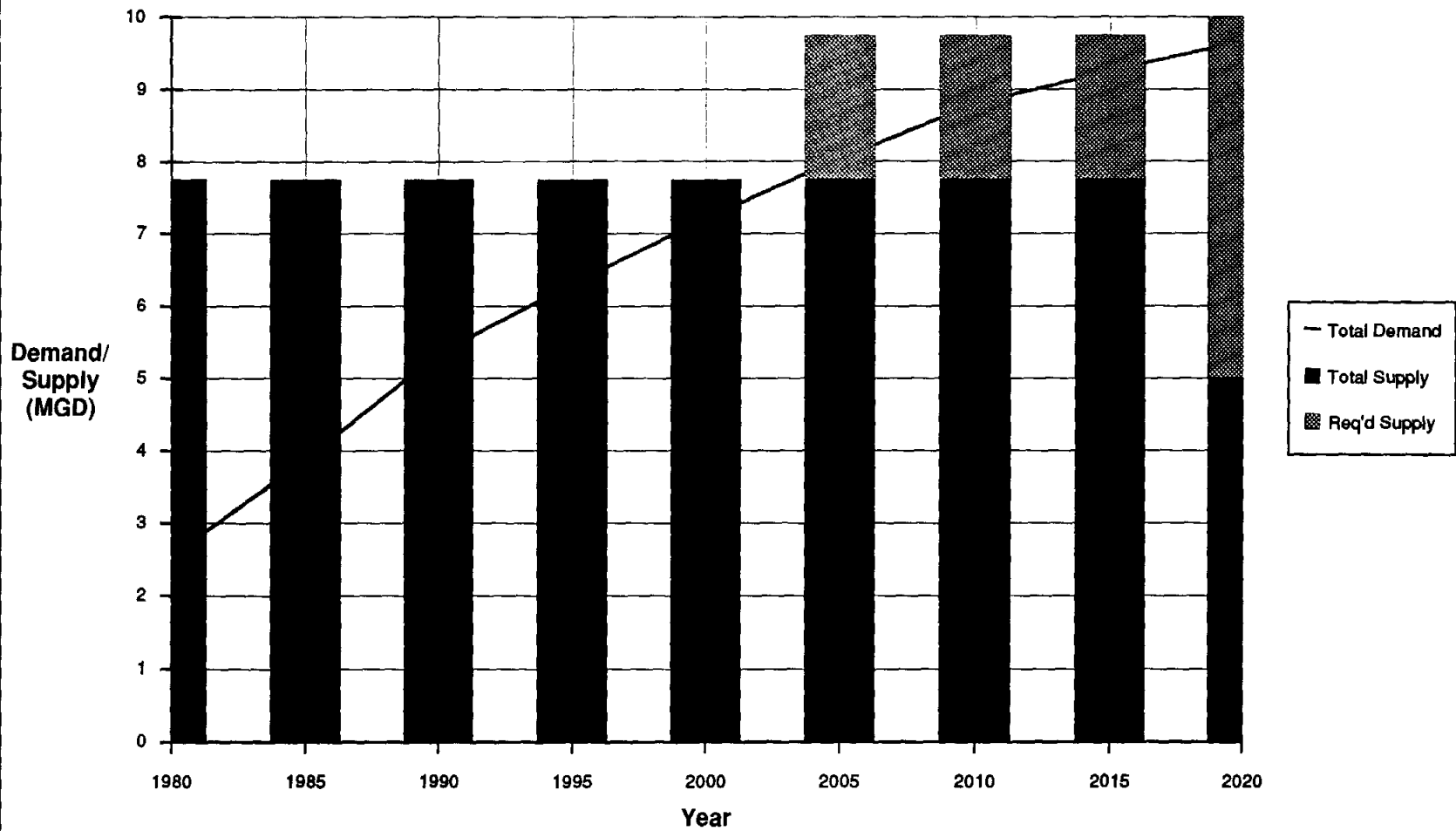

Figure 5-3  
 Probable Case Projected CRWA Member  
 Future Water Demand and Supplies

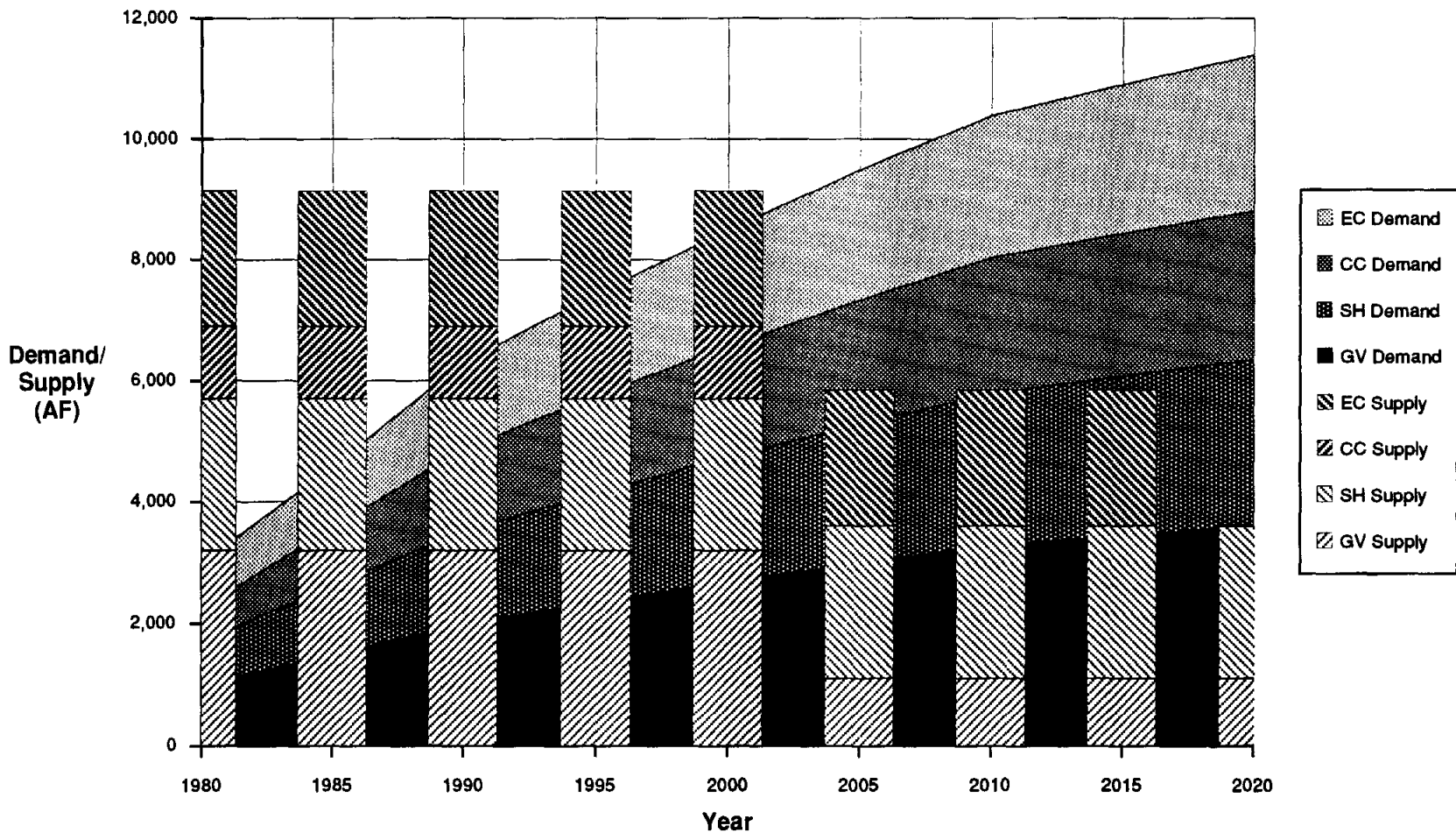
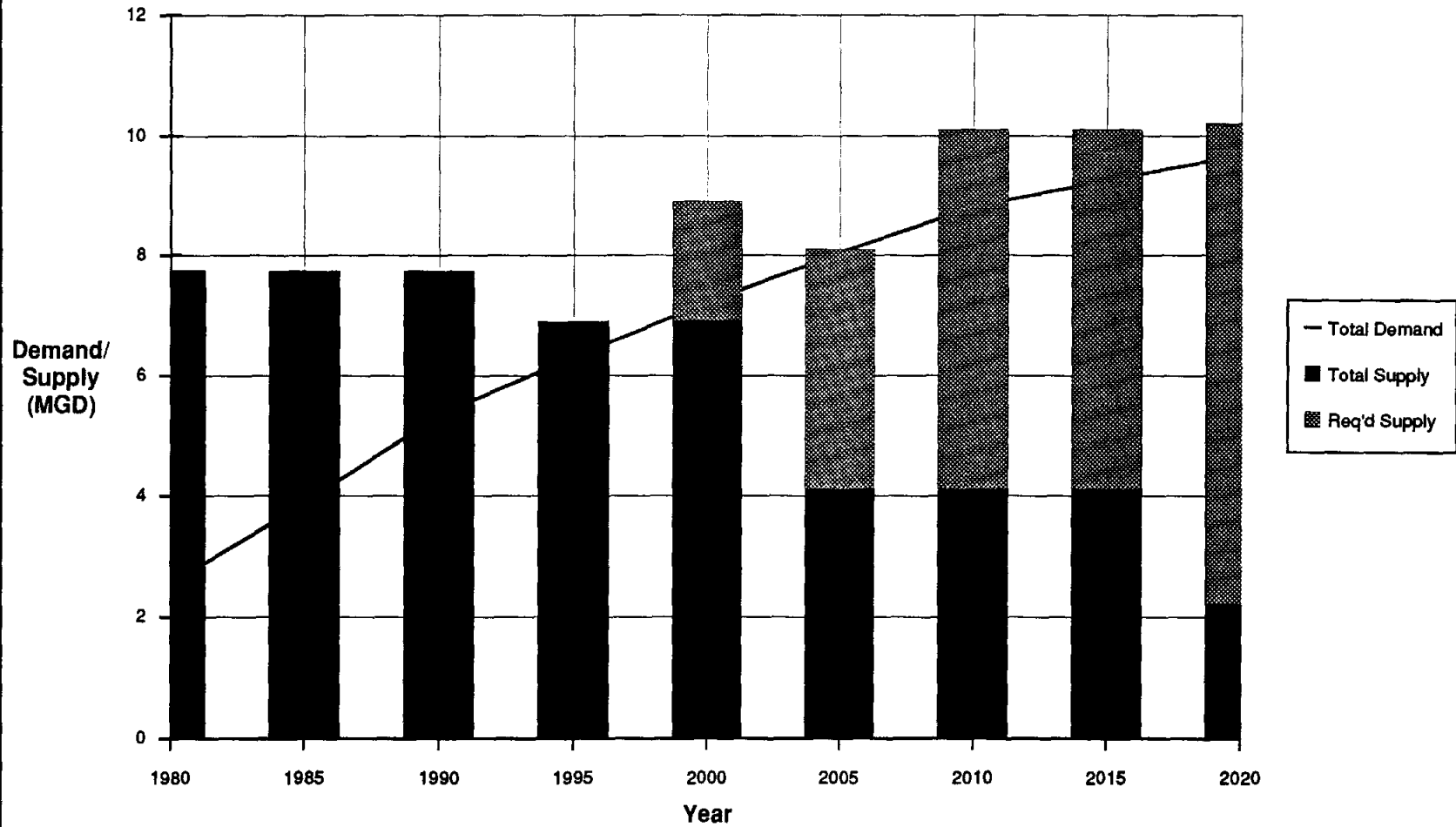

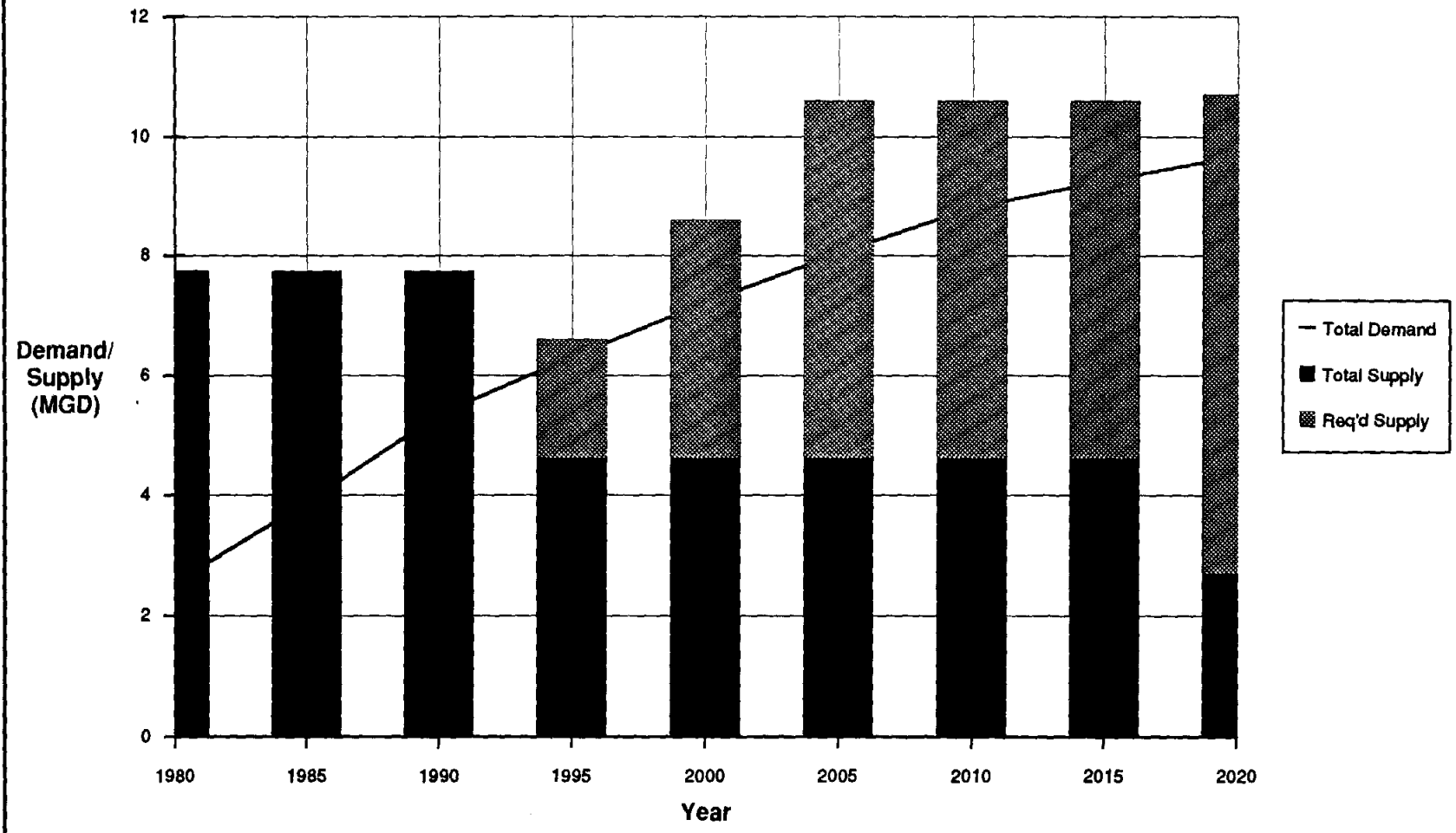

Figure 5-4  
Probable Case Projected CRWA Member Future Water  
Demand and Required Supplemental Supplies





**Figure 5-6  
Worst Case Projected CRWA Member Future Water  
Demand and Required Supplemental Supplies**



**Figure 5-7  
Drought Case Projected CRWA Member Future Water  
Demand and Supplies**

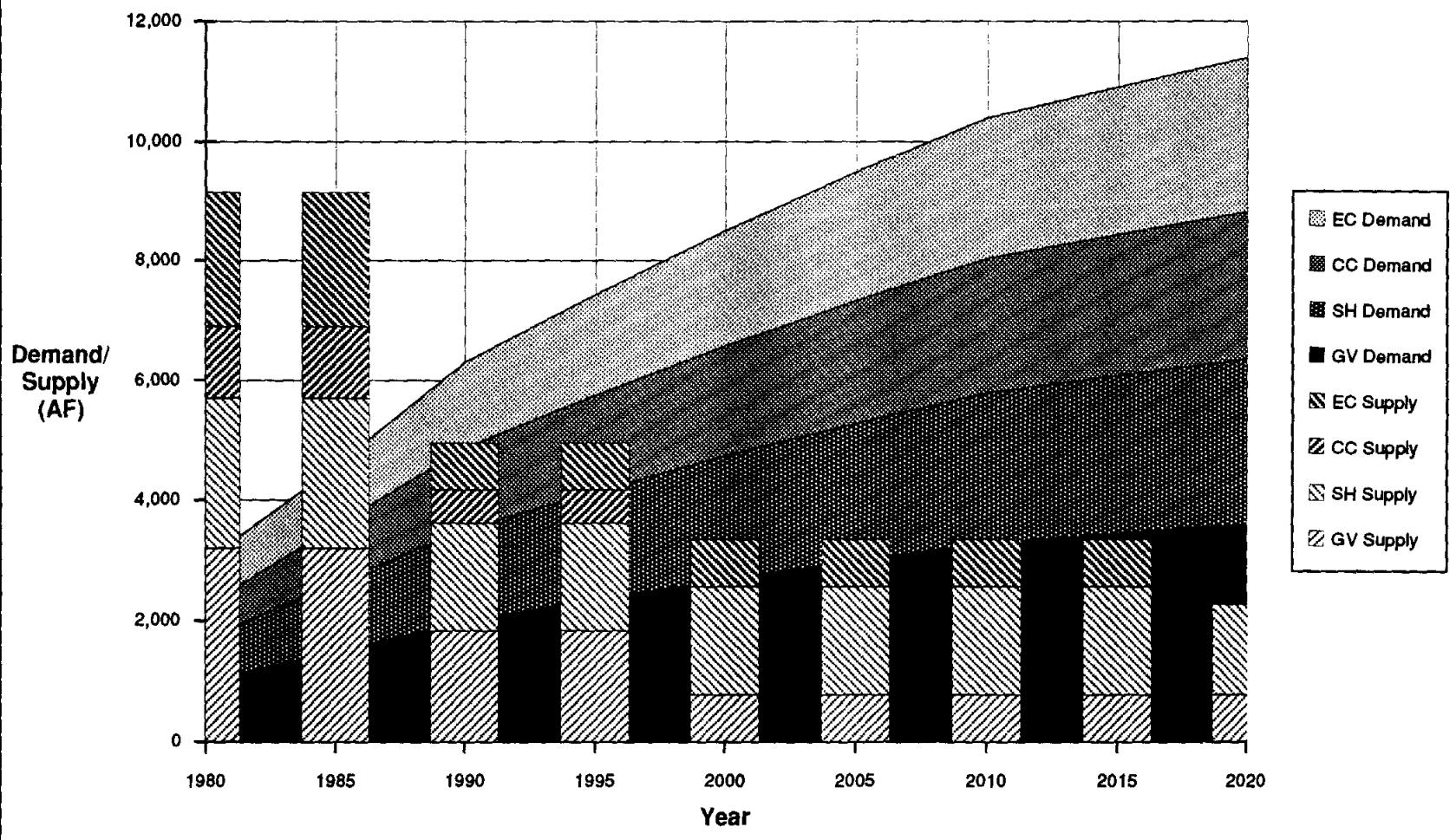

Figure 5-8  
Drought Case Projected CRWA Member Future Water  
Demand and Required Supplemental Supplies

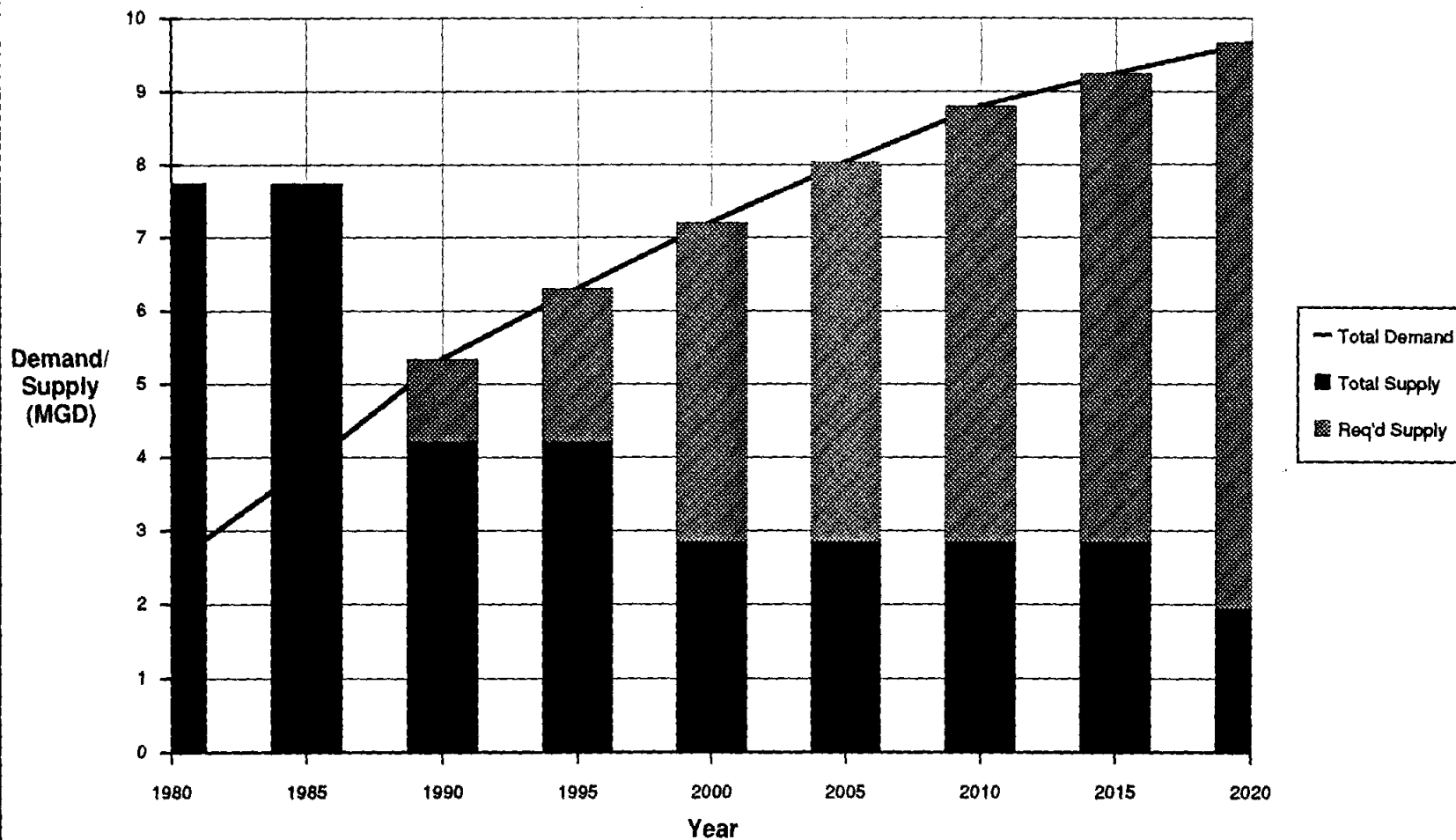
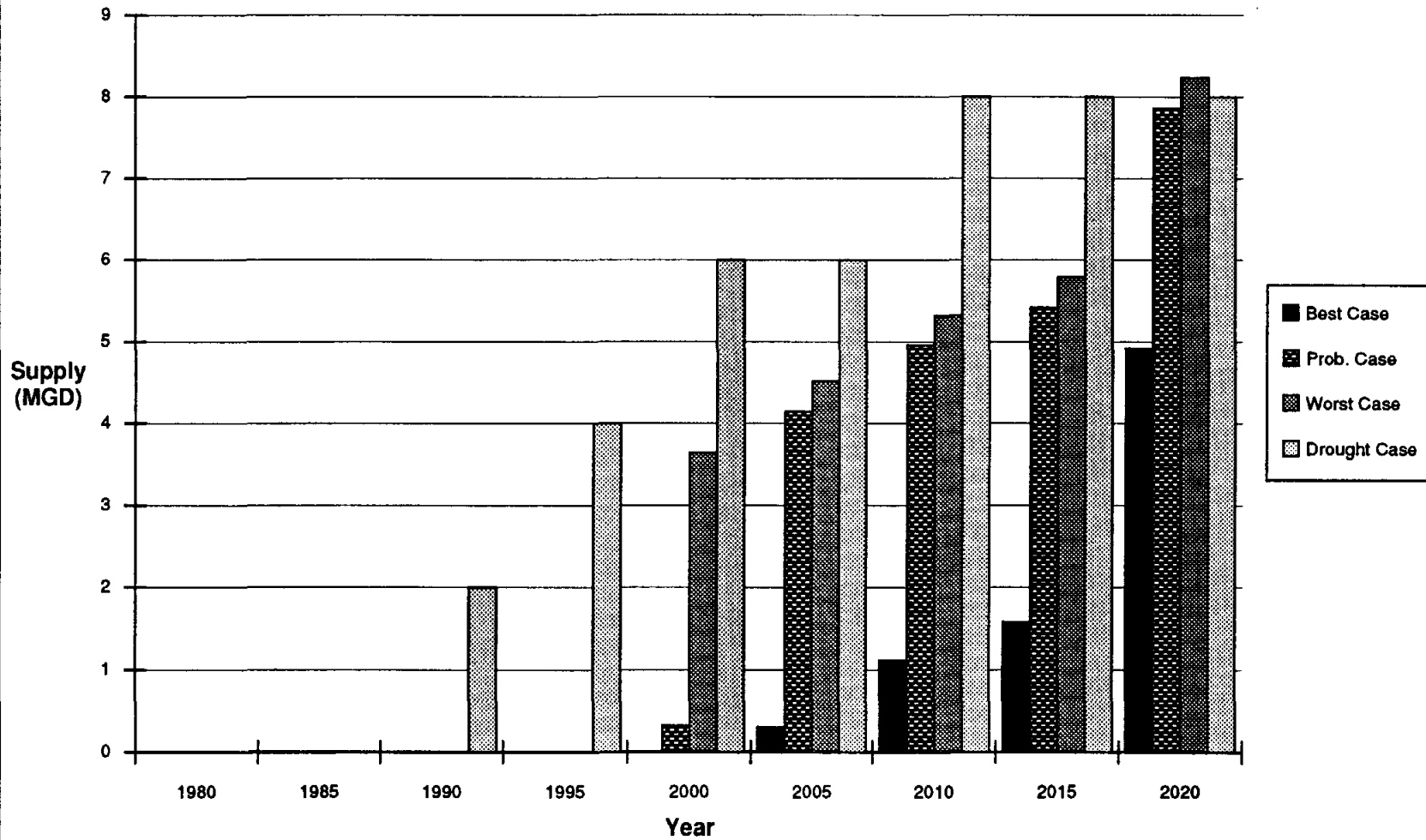

Figure 5-9  
Projected CRWA Member Future Required Supplemental Supplies



## **6.0 PRELIMINARY WATER SUPPLY OPTION EVALUATION**

### **6.1 Scope of Supply Option Search**

The goal of the supply option search was to identify all of the remotely feasible water sources that could serve as a future supply to CRWA member WSCs. Unless constrained, such a search can cost time and effort pursuing infeasible options. For this study, the supply option search was limited to the Lower Guadalupe Basin (Canyon Reservoir to San Antonio Bay) and the Lavaca-Guadalupe and San Antonio-Guadalupe Coastal Basins (Figure 6-1). The San Antonio Basin was explicitly excluded from consideration to avoid confrontation with the TWDB interbasin transfer policies.

### **6.2 Supply Option Selection Criteria**

All Supply options for evaluation as candidates for CRWA must:

- be physically possible,
- be capable of producing significant quantities of water,
- not result in unreasonable negative environmental impacts,
- be legal and not violate regulatory or jurisdictional controls or boundaries.

### **6.3 Supply Option Evaluation Criteria**

A water supply option evaluation matrix was developed which would allow supply options to be evaluated numerically. The evaluation criteria were divided into two broad categories: Engineering Considerations and Institutional and legal Considerations. The Engineering Considerations category included: Engineering Feasibility; Firmness of Supply; Flexibility; and, Environmental Impacts. Institutional and Legal Considerations included: Legal Considerations; Institutional Considerations; and, Public Acceptance. Each evaluation criteria was given a numerical value which ranged from a negative value to a positive value of equal amount. Certain criteria were weighted more heavily than others due to their perceived relative impact on the total option. Options which scored low on the matrix were considered to be less attractive than options which scored high. The evaluation matrix categories, and their numerical ranges, are summarized below:

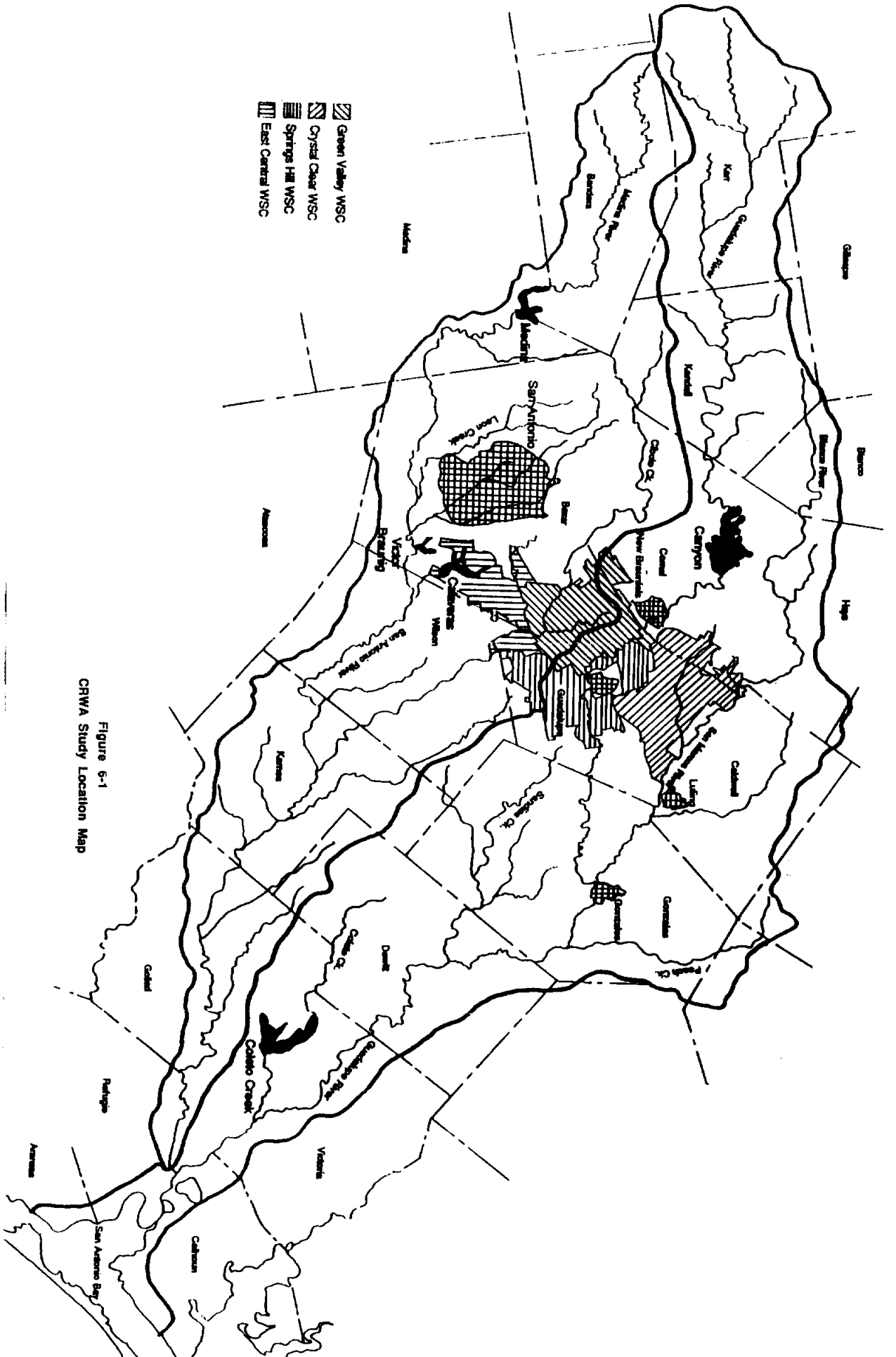

Figure 6-1  
CRWA Study Location Map



**CANYON REGIONAL WATER SUPPLY STUDY  
PRELIMINARY WATER SUPPLY OPTION EVALUATION**

<b>Evaluation Category</b>	<b>Numerical Range</b>
Engineering Feasibility	-10 to +10
Firm Supply	-10 to +10
Legal Considerations	-8 to +8
Institutional Considerations	-6 to +6
Public Acceptance	-6 to +6
Flexibility	-2 to +2
Environmental	-2 to +2

In order to compare supply options on an equal basis, a baseline option was developed. Numerically, the baseline option scores a zero, when evaluated using the matrix criteria.

**6.3.1 Baseline Description**

The baseline supply option was developed based upon the following assumptions:

- Construct a centrally located surface water treatment plant which uses conventional chemical treatment processes.
- Obtain water supply from a river source without benefit of impoundment structure(s).
- River flow rates are inadequate, in themselves, to provide necessary supply year-round.
- Sufficient supply is available approximately fifty percent of the time.
- Pumping facilities will be required to deliver treated water to the CRWA service area.
- Pumping facilities will be located within the general boundary of the CRWA service area.
- Transmission mains will be required to deliver treated water to the individual service areas.
- Transmission mains will be located within the general boundary of the CRWA service area.

Supply options which, when compared to the baseline option, would require relatively more intensive methods of providing supply were ranked lower. Supply options which, when compared to the baseline option, would require relatively less intensive methods of providing supply, were ranked higher. Additionally, each supply option was evaluated for its anticipated short-term and long-term impact on the overall CRWA system.

**CANYON REGIONAL WATER SUPPLY STUDY  
PRELIMINARY WATER SUPPLY OPTION EVALUATION**

Use of the short-term/long-term terminology is subjective and context sensitive. Options which are affected in the short-term are assumed generally to be those options which exhibit a noticeable benefit or detriment during the first ten-year planning period (1990 to 2000). Options which are affected in the long-term are assumed generally to be those options which exhibit a noticeable benefit or detriment during the final ten-year planning period (2010 to 2020). The period between 2000 and 2010 may generally be considered as a transition period, during which, implementation of a specific option may or may not produce an obvious benefit or detriment to the overall CRWA system.

For each of the evaluation criteria, short-term and long-term, the following general rules were used to assign numerical values:

- Options which exceeded the requirements or capabilities of the baseline option, were assigned positive values.
- Options which met the requirements or capabilities of the baseline option, were assigned a value of zero.
- Options which failed to meet the requirements or capabilities of the baseline option, were assigned negative values.

### **6.3.2 Short-Term Option Evaluation Criteria**

In general terms, the options which scored high for short-term Engineering Considerations were those options which would minimize engineering design requirements; provide adequate supply for a brief period of time; integrate easily with the existing system; and, cause minimal damage to the environment. Options which scored low for short-term Engineering Considerations were generally those options which would require an intensive engineering design and implementation effort for a limited period of relief; could not guarantee a firm supply; were not easily integrated with the existing system; and, posed unwarranted danger to the environment.

Options which scored high for short-term Institutional and Legal Considerations were generally those options which were not fraught with legal obstacles or impediments; would fit in easily with existing institutional programs; and, be accepted by the public. Options which scored low for short-term Institutional and Legal Considerations were those options which were in apparent violation of current water law or would require extensive legal consultation to accomplish; would be totally unacceptable to the institution which controlled the water needed to implement the option; and, would be unacceptable to the public.

### 6.3.3 Long-Term Option Evaluation Criteria

The options which scored high for long-term Engineering Considerations were those options which would require fewer incremental modifications to the system to keep pace with growth; provide firm supply for an extended period; meet the demands of an expanding system in terms of system flexibility; and, minimize damage to the environment. Options which scored low for long-term Engineering Considerations were those options which would require extensive engineering and implementation strategies to obtain supply, regardless of the duration of the planning period; offer limited integration possibilities with the existing system; and, cause damage to the environment.

Options which scored high for long-term Institutional and Legal Considerations were those options which would not present obvious legal complications; would be easily integrated into long range planning goals of affected water rights holders; and, would gain public acceptance. Options which scored low for long-term Institutional and Legal Considerations were those options which presented complicated legal obstacles or impediments; did not fit easily into the future planning goals of affected water rights holders; and, would be viewed unfavorably by the public.

## 6.4 Supply Option Description

### 6.4.1 Limited/No Action Alternative

The benchmark against which all possible CRWA future development alternatives must be measured is the "No Action" Alternative. The questions that must inevitably be asked as part of this or any, planning effort are:

- Is a "No Action" Alternative a feasible option? and
- What are the consequences of selection of "No Action" as the preferred alternative?

A corollary to the "No Action" Alternative is the "Limited Action" Alternative. The "Limited Action" Alternative is determined as that minimum effort necessary to avoid the major consequences of the "No Action" Alternative.

The long and short term No/Limited Action Alternatives selected for the CRWA members are:

#### Short-term Options (No Action)

- Green Valley WSC Continue to pump from the Edwards Aquifer to the maximum extent and duration allowed under conditions of existing permits and grandfathered water rights.

CANYON REGIONAL WATER SUPPLY STUDY  
PRELIMINARY WATER SUPPLY OPTION EVALUATION

East Central WSC Continue to purchase water from the City of San Antonio to the maximum extent and duration allowed under the conditions of existing contracts.

Crystal Clear WSC Continue to pump from the Edwards Aquifer and to purchase additional supplies from the Springs Hill WSC to the maximum extent and duration allowed under conditions of existing permits, supply agreements and contracts.

Springs Hill WSC Continue to purchase surface water from the Guadalupe-Blanco River Authority and the City of New Braunfels to the maximum extent and duration allowed under conditions of existing agreements and contracts.

Long-term Options (Limited Action)

Green Valley WSC Apply to the Edwards Underground Water District for renewal of existing permits and new permits to drill additional wells into the Edwards Aquifer sufficient to supply the future needs of CRWA members and municipalities within the CRWA services area.

East Central WSC Exercise existing options to renew supply agreements with the City of San Antonio and supplement supplies with purchases of water from the Green Valley WSC.

Crystal Clear WSC Apply to the Edwards Underground Water District for renewal of existing permits and new permits to drill additional wells into the Edwards Aquifer sufficient to supply the future needs of CRWA members and municipalities within the CRWA services area.

Springs Hill WSC Renew or extend existing contracts with the GBRA and City of New Braunfels for surface water and supplement supplies with purchases of water from Green Valley and Crystal Clear WSCs.

6.4.2 Purchase Supplies from Others

Guadalupe Blanco River Authority

The GBRA currently holds a Texas Water Rights Permit to impound Guadalupe River flood flows in Canyon Reservoir and to sell approximately 50,000 AF/yr of water to users in the Guadalupe River Basin. The GBRA and GVWSC have discussed the purchase of water from Canyon Reservoir. And, apparently two supply/treatment development scenarios have evolved from those discussions.

CANYON REGIONAL WATER SUPPLY STUDY  
PRELIMINARY WATER SUPPLY OPTION EVALUATION

- **GVWSC can purchase water from the GBRA under a take-or-pay contract arrangement at a rate of approximately \$45/AF and construct and operate their own surface water treatment plant or**
- **GBRA will build and operate a surface water treatment plant within or in close proximity to the CRWA service area and sell treated water to the CRWA member WSCs for distribution in their systems.**

**Presumably these options would also be available to all CRWA members. The second surface water treatment facility would augment the treatment capacity of the existing SHWSC facility near Seguin.**

**There is a third possible option involving the purchase of water from the GBRA. The City of Seguin owns and operates a surface water treatment facility on the Guadalupe River with a maximum treatment capacity of 13 MGD. Seguin has a 7,000 AF/yr ( $\approx$ 6 MGD) run-of-the-river type diversion with a supplemental supply of 2,500 AF/yr ( $\approx$ 2 MGD) recently purchased from the GBRA. Therefore, at full permitted production, the City of Seguin can treat approximately 9,500 AF/yr ( $\approx$ 8 MGD) at their facility. Currently the City of Seguin treats an annual average of 4.3 MGD with a peak diversion rate of 7 MGD (Peak  $\approx$  1.63 x Average). Using similar future water demand projections for the City of Seguin as were developed in Sections 3.2.2 for the CRWA member WSCs, it can be demonstrated through the following arguments that there is currently excess capacity available in the Seguin Plant.**

**Assuming a conservative Peak: Average ratio (much higher than observed historically for the City of Seguin) the High Population Series - High Per Capita Use - Without Conservation peak flows are projected to be from approximately 8.3 MGD in 1990 to approximately 12.8 MGD in 2020 (Figure 6-2). In 1995 there will be approximately 4 MGD of excess available capacity in the Seguin Plant. In 2020 that number will have been reduced to 3 MGD; in 2005 to 2.5 MGD; and in 2000 to 2.0 MGD. Thus for the next twenty years there will be at least 2 MGD of excess capacity in the existing Seguin treatment facility. Therefore, the following short-term development scenarios are offered.**

- **CRWA purchase surface water supplies (under an assumed take-or-pay contractual arrangement) from the GBRA. Defer construction of a CRWA surface water treatment facility and instead lease treatment capacity in the Seguin Plant.**

**This option offers deferred construction of a CRWA plant until such time as, if and when, the City of Seguin needs the capacity for their own needs or the CRWA customer base is sufficient to necessitate construction of its own treatment facilities.**

**The short and long- term Purchased GBRA Water Options for the CRWA members are:**

Figure 6-2  
City of Seguin Projections of Municipal Water Demands and  
Available Capacity High Per Capita Water Use Scenario

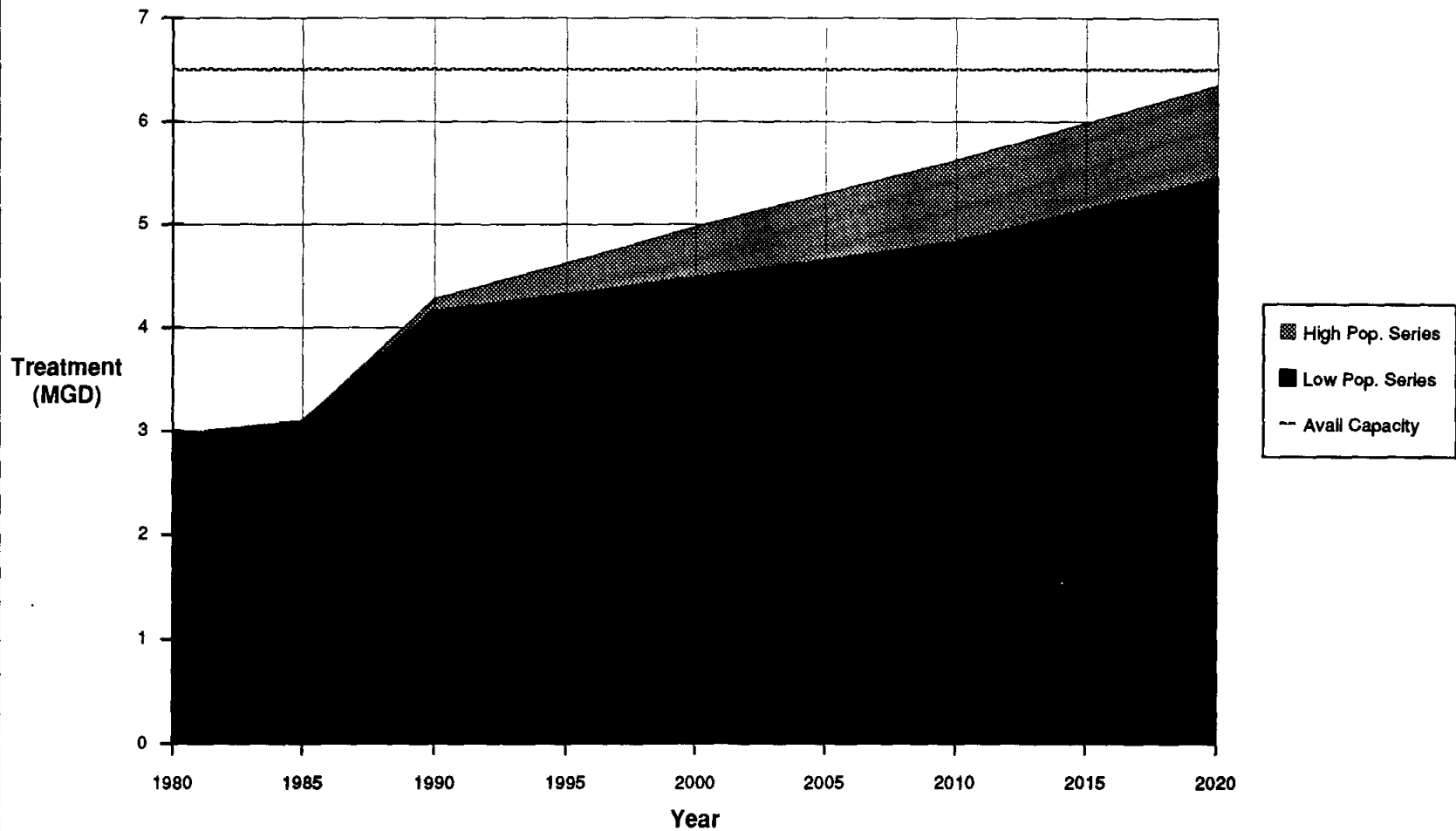

- **Short-term Options**

Continue to supply existing demands from existing long term contract supplies (including withdrawals from the Edwards Aquifer) to the maximum extent and duration allowed required under existing permits, agreements and supply contracts. Supplement supplies with additional short-term contractual purchases from the GBRA. Approach the City of Seguin about short-term contractual reservation of excess capacity in the existing City owned water treatment plant.

- **Long-term Options**

- a. Continue to supply existing demands from existing long-term contract supplies (including withdrawals from the Edwards Aquifer) to the maximum extent and duration allowed required under existing permits, agreements and supply contracts. Purchase additional long-term supplies from the GBRA or build additional surface water treatment capacity. Surface water treatment capacity could be constructed at the proposed Green Valley WSC site, expand the treatment capacity of the existing Springs Hill WSC treatment plant, construct a treatment plant at another site or implement a combination of treatment alternatives.
- b. Reduce or eliminate pumpage from the Edwards Aquifer and supply all demands with surface water supplies purchased from the GBRA. Surface water treatment capacity could be constructed at the proposed Green Valley WSC site, expand the treatment capacity of the existing Springs Hill WSC treatment plant, construct a treatment plant at another site or implement a combination of treatment alternatives.

#### **New Braunfels/San Marcos**

The Cities of New Braunfels and San Marcos are both in the process of firming their respective future water supplies through development, as in the case of New Braunfels, surface water sources or, as in the case of San Marcos, development of additional well capacity. The City of New Braunfels has recently signed a contract with the GBRA for 7,150 AF/yr (6.4 MGD) from Canyon Reservoir and is in the process of constructing a 10 MGD water treatment plant. The City of San Marcos is in the process of adding two new wells to its existing well field. However, it appears that purchase of water from the Cities of New Braunfels and San Marcos is only viable as a short-term option (Figure 6-3). Both entities intend to grow into their procured supplies and treatment capacities. As a short-term option CRWA could:

Figure 6-3  
City of New Braunfels Projections of Municipal Water Demands  
High Per Capita Water Use Series

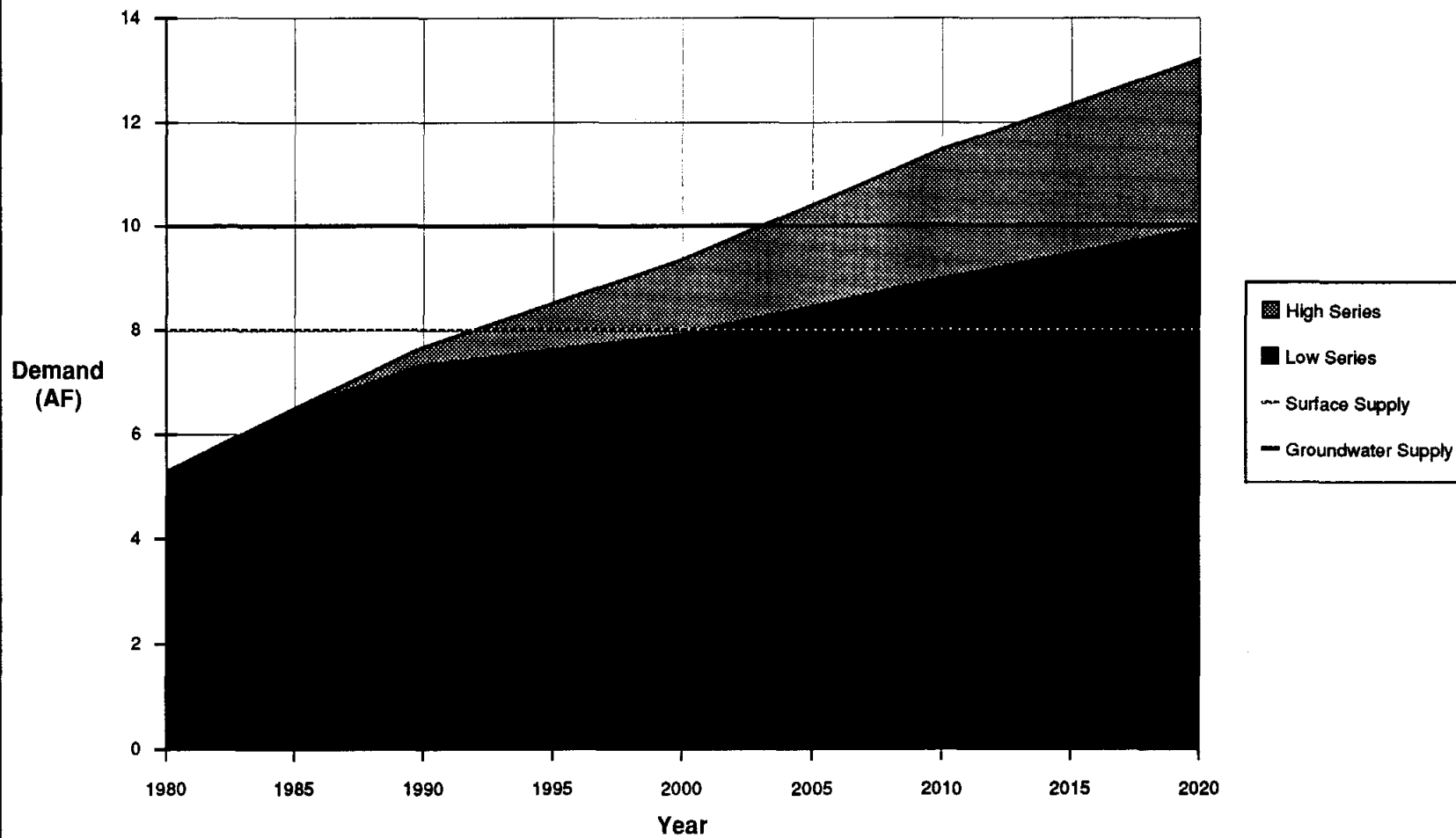



CANYON REGIONAL WATER SUPPLY STUDY  
PRELIMINARY WATER SUPPLY OPTION EVALUATION

- Purchase treated water from either or both Cities, or
- Purchase raw water from the City of New Braunfels and treat the water at either the City of Seguin Plant or a new CRWA facility.

**Edwards Underground Water District**

The Edwards Underground Water District (EUWD) has and continues to support management of the aquifer through controlled pumpage and maximization of aquifer recharge. The EUWD is currently involved in several projects aimed at promotion of aquifer recharge including the Lake Medina Projects. The CRWA could participate in one or more of EUWDs recharge enhancement projects in return for a gradual increase in permitted pumping capacity sufficient to satisfy growth and demand within the service area.

This option should only be viewed as a short-term option, however, as it is unlikely that firm long-term commitments sufficient to satisfy CRWA would be granted to a user/pumper not directly located over the aquifer.

**Irrigation Rights**

The TWC provides a mechanism for the purchase and conversion of agricultural and industrial water rights to municipal rights. In order to effect such a transfer, however, there must be both a buyer and an available right. In addition, transfers are subordinate to all senior and superior rights within the system.

There are a total of 1,330 AF/yr of agricultural rights from the Guadalupe River in or near the CRWA service area. Therefore, conversion of irrigation rights is not a viable long-term supply option. The short-term option available to CRWA is:

- Short-term Option

Continue to supply existing demands from existing supplies (including withdrawals from the Edwards Aquifer) to the maximum extent and duration allowed under existing permits, agreements and supply contracts. Supplement supplies with purchase and conversion of irrigation water rights.

### 6.4.3 Wells

There are three potential groundwater sources available to the CRWA, exclusive of the Edwards Aquifer. Those options are: (1) shallow wells drilled to local perched groundwater formations, (2) wells drilled to the Leona Aquifer and (3) wells drilled to the Carrizo-Wilcox Aquifer.

#### Shallow Wells

As a short-term supply option, numerous shallow wells could be drilled into local perched groundwater supplies. These wells could be manifolded into the CRWA distribution system and used to supplement other ground and surface water supplies. The drawbacks to such a system, however, are numerous and this option should only be considered as a short-term supplement to existing supplies.

#### Leona Formation

Gravels of the Leona Formation underlie most of the CRWA service area. Thickness of the gravel ranges from 0 - 25 ft; the average thickness is approximately 10 ft. It appears from previous studies that the gravels of the Leona contain relatively small amounts of water and that the formation is principally recharged from the Guadalupe River. Therefore, pumping from the Leona Aquifer can only be considered as a relatively short-term adjunct to other supplies.

#### Carrizo-Wilcox

The Carrizo and Wilcox formations are considered by the State to be one major aquifer. Both formations underlie the southern portions of Guadalupe County and most of Wilson County (Figure 6-4). Wells to the Carrizo-Wilcox would be deep ( $\geq 1,200$  ft); however, the formation is relatively drought resistant and could supply sufficient quantities of good quality fresh water to satisfy future CRWA demands. Therefore, the long and short term options available using the Carrizo-Wilcox Aquifer are:

- Short-term Options

- Continue to supply existing demands from existing supplies (including withdrawals from the Edwards Aquifer) to the maximum extent and duration allowed under existing permits, agreements and supply contracts. Supplement supplies with numerous shallow wells to minor near-surface water bearing strata.

- Long-term Options

- a. Continue to supply existing demands from existing supplies (including withdrawals from the Edwards Aquifer) to the maximum extent and duration allowed under existing permits,

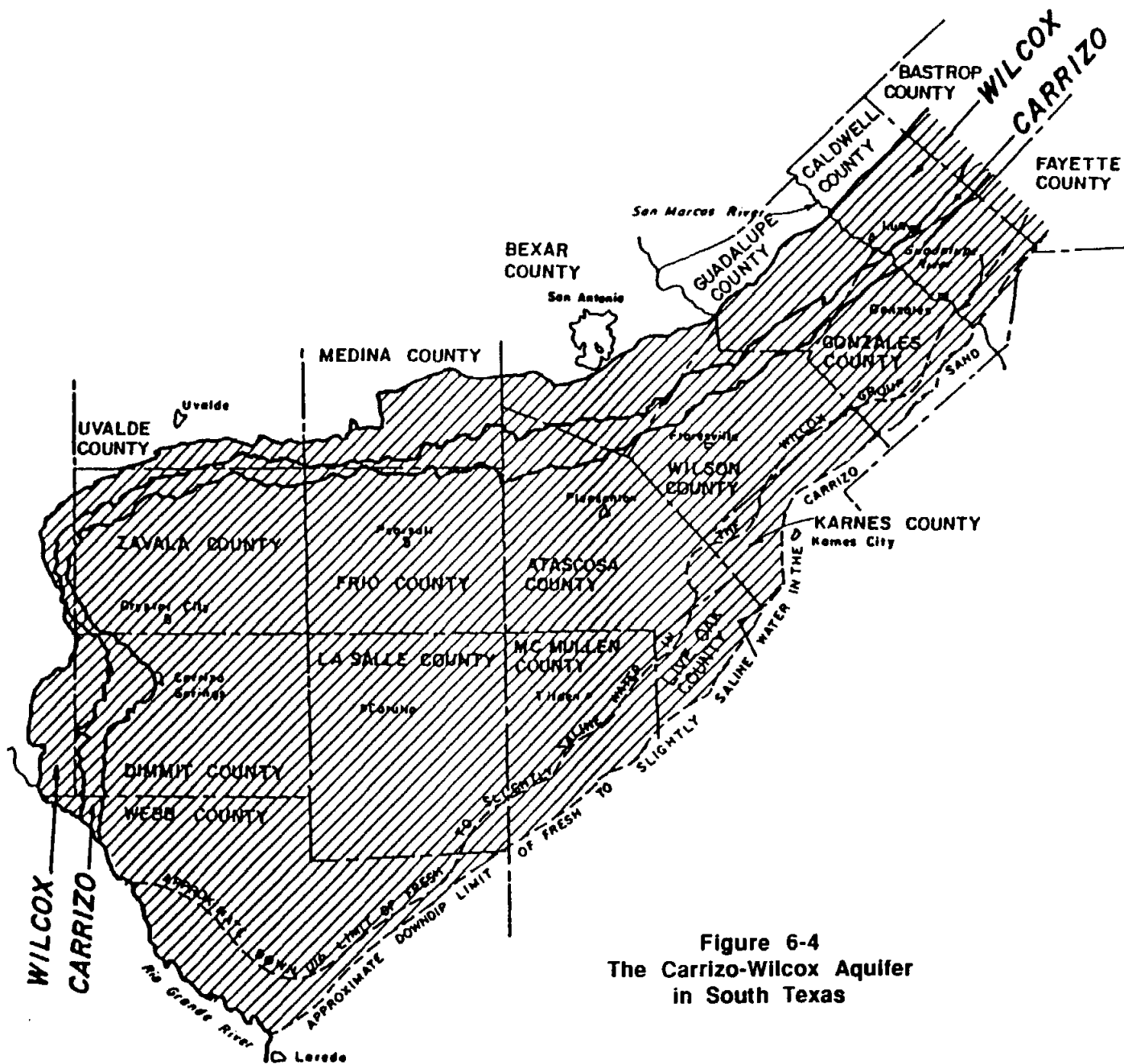

Figure 6-4  
 The Carrizo-Wilcox Aquifer  
 in South Texas

**CANYON REGIONAL WATER SUPPLY STUDY  
PRELIMINARY WATER SUPPLY OPTION EVALUATION**

agreements and supply contracts. Supplement supplies with wells drilled into the Leona and Carrizo-Wilcox Aquifers.

- b. Reduce or eliminate pumpage from the Edwards Aquifer and supply all demands with groundwater obtained from other aquifers.

**6.4.4 Conjunctive Use/Subordination of GBRA Hydropower Rights**

The GBRA owns seven (7) hydropower generation structures on the Guadalupe River between Canyon Reservoir and Gonzales (Tables 6-1 through 6-3 and Figures 6-5 through 6-7). Six (6) of these GBRA hydropower structures have non-consumptive water rights dating back to the early 1900s.

<b>Permit Number</b>	<b>Facility Designator</b>	<b>Authorized Amount (AF/yr)</b>	<b>Priority Date</b>
0021	GBRA TP-1	663,145	04/01/14
0021	GBRA TP-3	659,995	04/01/14
0021	GBRA TP-4	665,323	04/01/14
0021	GBRA TP-5	605,884	04/01/14
1096	GBRA H-4	579,180	09/16/26
1096	GBRA H-5	572,010	09/16/26

In addition to the totalized quantitative non-consumptive use authorization of over 650,000 AF/yr, the Guadalupe River Adjudication prescribes a 1,300 cfs minimum flow restriction within the reach of the river between Canyon Reservoir and Gonzales.

The Guadalupe Valley Electric Coop (GVEC) is the exclusive purchaser of electric power generated by the six GBRA hydropower facilities. The GVEC tells the GBRA when and how much electricity it needs and identifies which generating station will be needed to generate the power. The GBRA then releases stored water from Canyon Reservoir at a rate that when added to the flows of the Comal River and Comal Springs at New Braunfels will be sufficient for electric power generation (not necessarily 1,300 cfs). When GVEC is not requesting Canyon releases for power generation, GBRA maintains a riverflow of approximately 350 cfs, required by the City of Seguin to run its hydropower plant located on the Guadalupe River near the City. When the City of Seguin is not generating power, GBRA is required to pass Canyon Reservoir inflows plus sufficient water, when summed with Comal River and Comal Springs flows, to satisfy contractual downstream obligations.

**Table 6-1**  
**TP-1 Dam and Lake Dunlap**

**OWNER**

Guadalupe-Blanco River Authority.

**ENGINEER**

Fargo Engineering Company.

**LOCATION**

On the Guadalupe River in Guadalupe County, 9 miles northwest of Seguin.

**DRAINAGE AREA**

1,667 square miles, River flow partly regulated by Canyon Reservoir.

**DAM**

Type	Earthfill with concrete spillway
Length	2,000 ft
Height	41 ft
Elevation top of dam	588 ft above msl

**SPILLWAY**

Type	Floating crest
Length	255 ft
Crest elevation	563.2 ft above msl
Control	3 roof-weir gates, each 85 by 12 ft

**OUTLET WORKS**

None. Water is released through turbines while generating power. Lake is maintained at opening level by regulating power output.

**POWER GENERATING FEATURES**

Two generating units with a total capacity of 3,600 kw.

**STATE AUTHORIZATION**

TP-1 Dam and Lake Dunlap were authorized under Permit No. 21 (Application No. 21) dated July 25, 1914, which allows the appropriation and use of an amount of the public waters of the State at a rate not to exceed 1,300 cubic feet per second of time continuously for the purpose of hydroelectric power generation.

**RESERVOIR DATA**

Capacity	5,900 acre-feet at elevation 575.0 ft above msl
Area	410 acres at elevation 575.0 ft above msl
Usable storage capacity	3,550 acre-feet

Water is diverted by a 2-mile long canal to the powerplant.

**GENERAL**

Construction started	1927
Dam completed	1928
Impoundment of water began	1928
Generation of power began	1928
General contractor	Sumner and Sollet

This is one of six projects owned and operated by Guadalupe-Blanco River Authority which were purchased from the original owners.

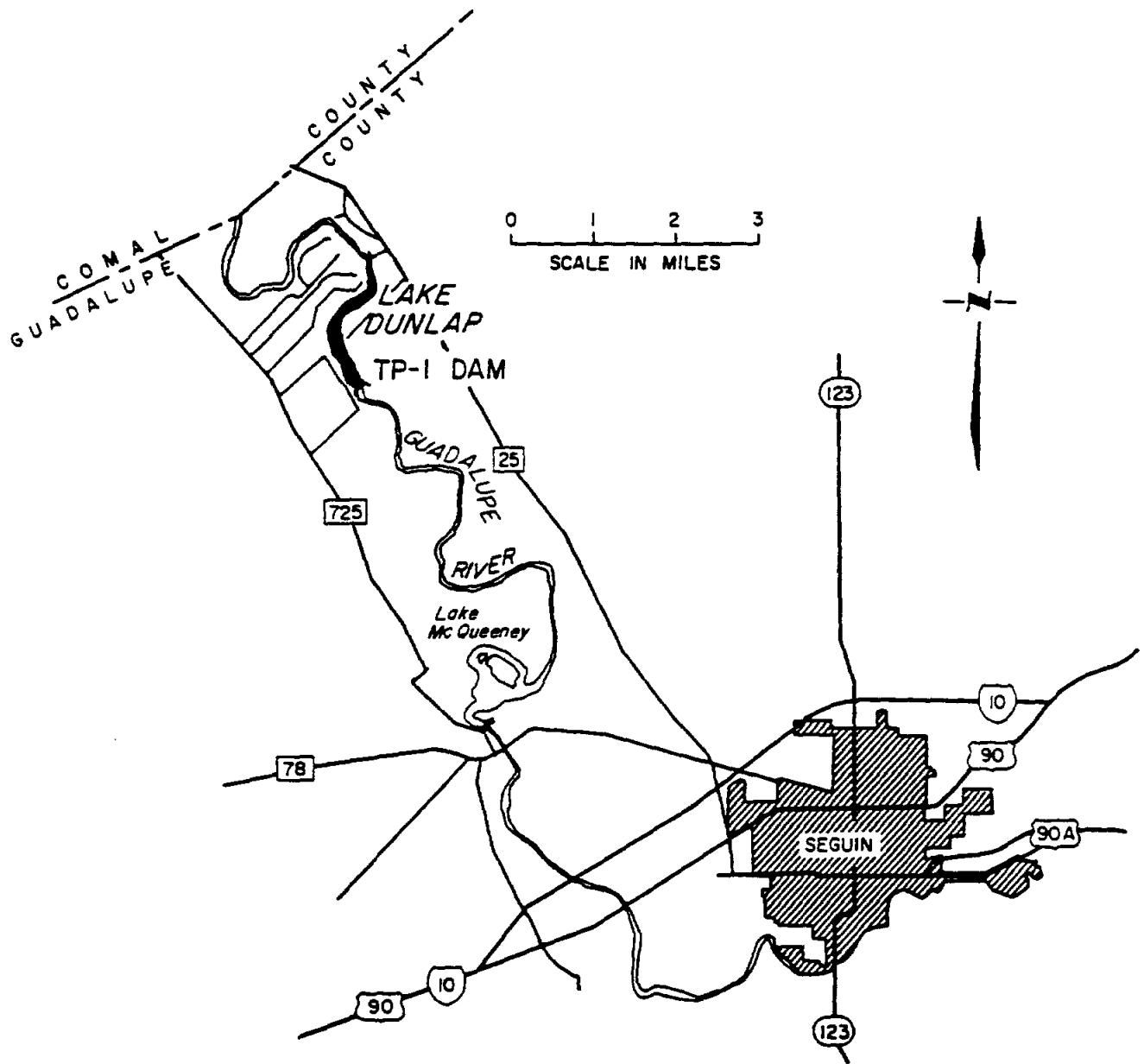

Figure 6-5  
 Location Map  
 GBRA Hydropower Dam  
 TP-1 (Lake Dunlap)

Table 6-2

Abbott Dam (TP-3) and Lake McQueeney

**OWNER**

Guadalupe-Blanco River Authority.

**ENGINEER**

Fargo Engineering Company.

**LOCATION**

On the Guadalupe River in Guadalupe County, 5 miles west of Seguin.

**DRAINAGE AREA**

1,697 square miles, River flow partly regulated by Canyon Reservoir.

**DAM**

Type	Earthfill with concrete spillway
Length	1,900 ft
Height	40 ft
Elevation top of dam	540 ft above msl

**SPILLWAY**

Type	Floating crest
Length	255 ft
Crest elevation	516.7 ft above msl
Control	3 roof-weir gates, each 85 by 12 ft

**OUTLET WORKS**

None. Water is released through turbines while generating power. Lake is maintained at opening level by regulating power output.

**POWER GENERATING FEATURES**

Two generating units with a total capacity of 2,800 kw.

**STATE AUTHORIZATION**

Abbott Dam (TP-3) and Lake McQueeney were authorized under Permit No. 21 (Application No. 21) dated July 25, 1914, which allows the appropriation and use of an amount of the public waters of the State at a rate not to exceed 1,300 cubic feet per second of time continuously for the purpose of hydroelectric power generation.

**RESERVOIR DATA**

Capacity	5,000 acre-feet at elevation 528.7 ft above msl
Area	396 acres at elevation 528.7 ft above msl
Usable storage capacity	5,000 acre-feet

**GENERAL**

Construction started	1927
Dam completed	1928
Impoundment of water began	1928
Generation of power began	1928
General contractor	Sumner and Sollet

This is one of six projects owned and operated by Guadalupe-Blanco River Authority which were purchased from the original owners.

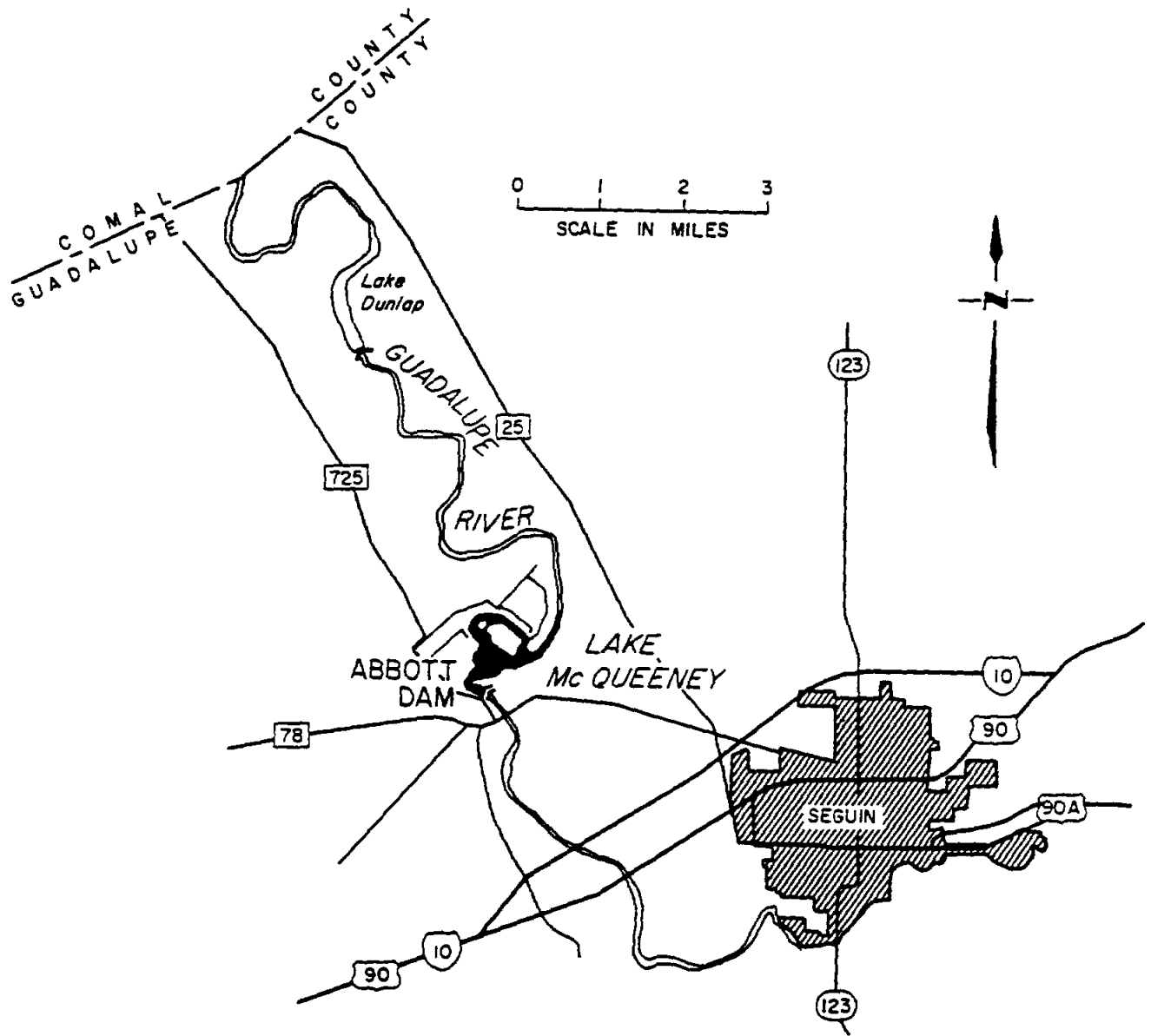

Figure 6-6  
Location Map  
Lake McQueeney



**Table 6-3**

**H-4 Dam and H-4 Reservoir**

**OWNER**

Guadalupe-Blanco River Authority.

**ENGINEER**

Fargo Engineering Company.

**LOCATION**

On the Guadalupe River in Gonzales County, 4 miles southeast of Belmont.

**DRAINAGE AREA**

2,048 square miles, River flow partly regulated by Canyon Reservoir.

**DAM**

Type	Earthfill with concrete spillway
Length	5,100 ft
Height	42 ft
Elevation top of dam	345.0 ft above msl

**SPILLWAY**

Type	Floating crest
Length	170 ft
Crest elevation	320.0 ft above msl
Control	2 roof-weir gates, each 85 by 12 ft

An uncontrolled section provides additional flood flow discharge.

**OUTLET WORKS**

None. Water is released through turbines while generating power. Reservoir is maintained at operating level by regulating power output.

**POWER GENERATING FEATURES**

One generating units with a capacity of 2,400 kw.

**STATE AUTHORIZATION**

H-4 Dam and Reservoir were authorized under Permit 1096 (Application No. 1163) dated June 12, 1929, which allows impoundment of 33,500 acre-feet of water in five reservoirs and an annual use of 941,200 acre-feet of generation of hydroelectric power. H-4 Dam was built and is located at the site of Dam No. 4 described in this permit. Continuous rate of flow through H-4 was authorized at 1,250 cubic feet per second, and authorized storage capacity was 7,500 acre-feet. This includes water rights from Permit No. 21 dated July 25, 1914.

**RESERVOIR DATA**

Capacity	6,500 acre-feet at elevation 332.0 ft above msl
Area	696 acres at elevation 332.0 ft above msl
Usable storage capacity	5,200 acre-feet

**GENERAL**

Construction started	1929
Dam completed	1931
Impoundment of water began	1931
Generation of power began	1931
General contractor	Sumner and Sollet

This is one of six projects owned and operated by Guadalupe-Blanco River Authority which were purchased from the original owners.

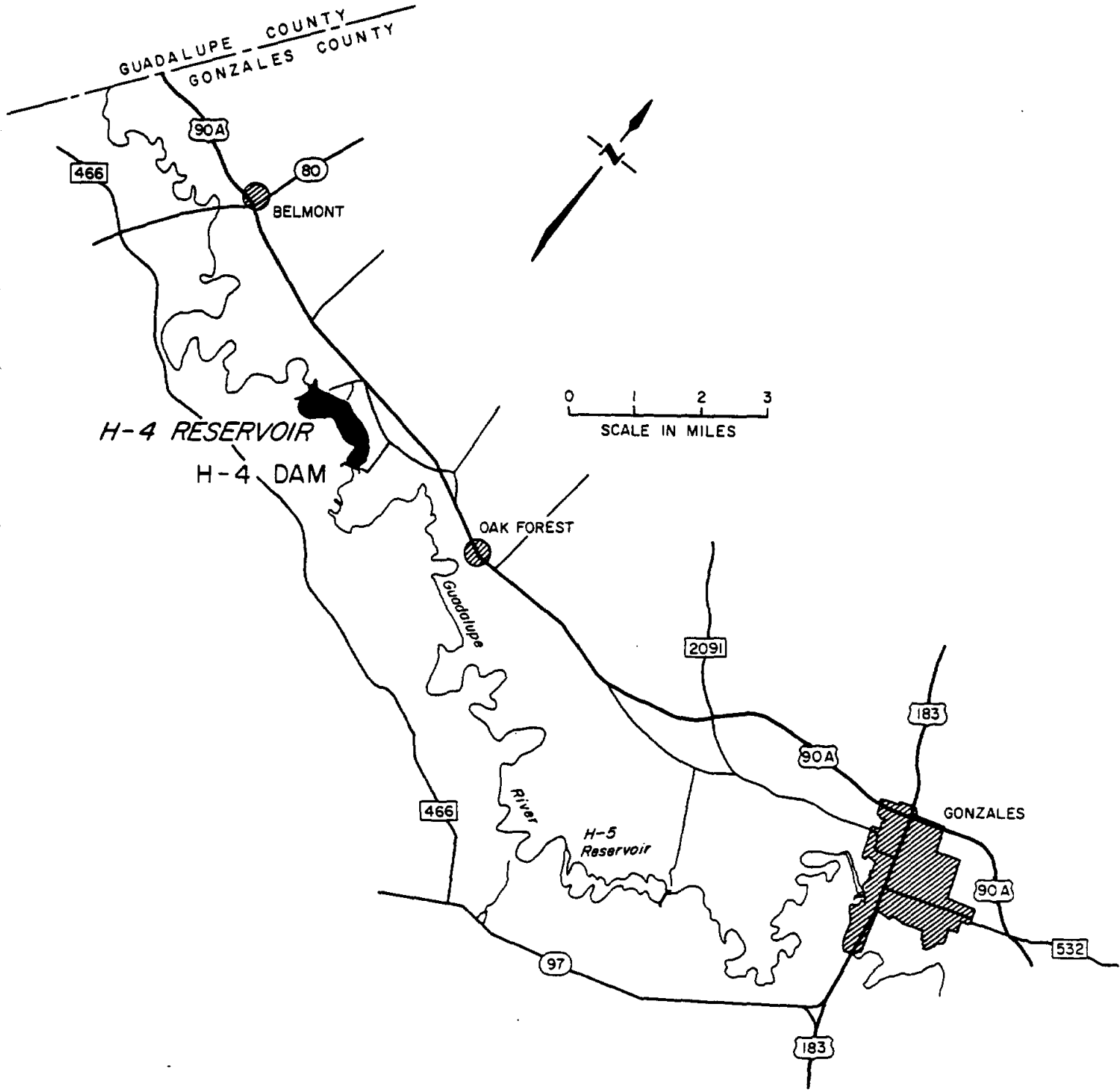

**Figure 6-7**  
**Location Map**  
**GBRA Hydropower Dams**  
**H-4 & H-5**

CANYON REGIONAL WATER SUPPLY STUDY  
PRELIMINARY WATER SUPPLY OPTION EVALUATION

The 1,300 cfs minimum continuous flow requirement between Canyon Reservoir and Gonzales serves to preclude water appropriations by any other user in this stretch of the river. The fact that the GVEC only uses these hydropower facilities as "peakers", generating power only during periods of peak demand does not in any way lessen the TWC authorized minimum flow diversion requirements.

The TWC, through application of its Water Rights Adjudication Model, determines unappropriated flow at various locations in the rivers and streams of Texas. The Guadalupe River Basin is divided into twenty-two (22) separate watersheds (Figure 6-8). The water rights (appropriations) within each watershed and the basin are quantified, prioritized and compared with historical flows available for satisfaction of those rights. Canyon Reservoir and the Comal River, sources of all water in the Guadalupe River within our study area are located in Watersheds 7 and 8 (Figure 6-9). Our study area is located partially in Watershed 9 and partially in Watershed 11 which includes Guadalupe, San Marcos and Blanco Rivers (Figure 6-10). Unappropriated water leaving Watershed 8, i.e., the combined flow of the Comal River and Canyon Reservoir releases is available for appropriation in Watershed 9. Examination of the Monthly TWC Model Unappropriated Water data set for the period 1940-1970 reveals essentially zero water available for appropriation between New Braunfels and Gonzales (Table 6-4). The reason is that the TWC Model considers only flows in excess of 1,300 cfs as available for appropriation irrespective of whether or not GVEC is using that water for power generation. In other words, if the flow in the Guadalupe River in this stretch of the river is 1,299 cfs, GVEC is not generating power and there are no other applicable water right restrictions on the flow, the TWC Model records zero water available for appropriation.

Examination of Monthly and Annual historical daily flow frequency distributions for Comal River at New Braunfels (Figures 6-11 and 6-12), the Guadalupe River above Comal at New Braunfels, i.e., Canyon Reservoir releases, (Figures 6-13 and 6-14) and the Combined Guadalupe and Comal Rivers Below New Braunfels (Figures 6-15 and 6-16) yields the following information.

- The monthly median (50% exceedance frequency) daily flows of the Comal River varies from approximately 360 cfs to 430 cfs. The annual median daily flow is approximately 410 cfs.
- The monthly median daily releases from Canyon Reservoir vary from less than 200 cfs to almost 500 cfs. However, the annual median daily flow of 120 cfs is considerably less than that of the Comal River
- The monthly median daily combined Comal River flows and Canyon Releases vary from 500 cfs to over 800 cfs. The percentage of time that flows are above 1,300 cfs varies from 12% as a minimum to 28% as a maximum. However, on an annual basis, the median daily flow is only 440 cfs and the time when flows are greater than 1,300 cfs is less than 5%. The data set is skewed slightly toward the high flows which is indicative of Canyon releases specifically for power

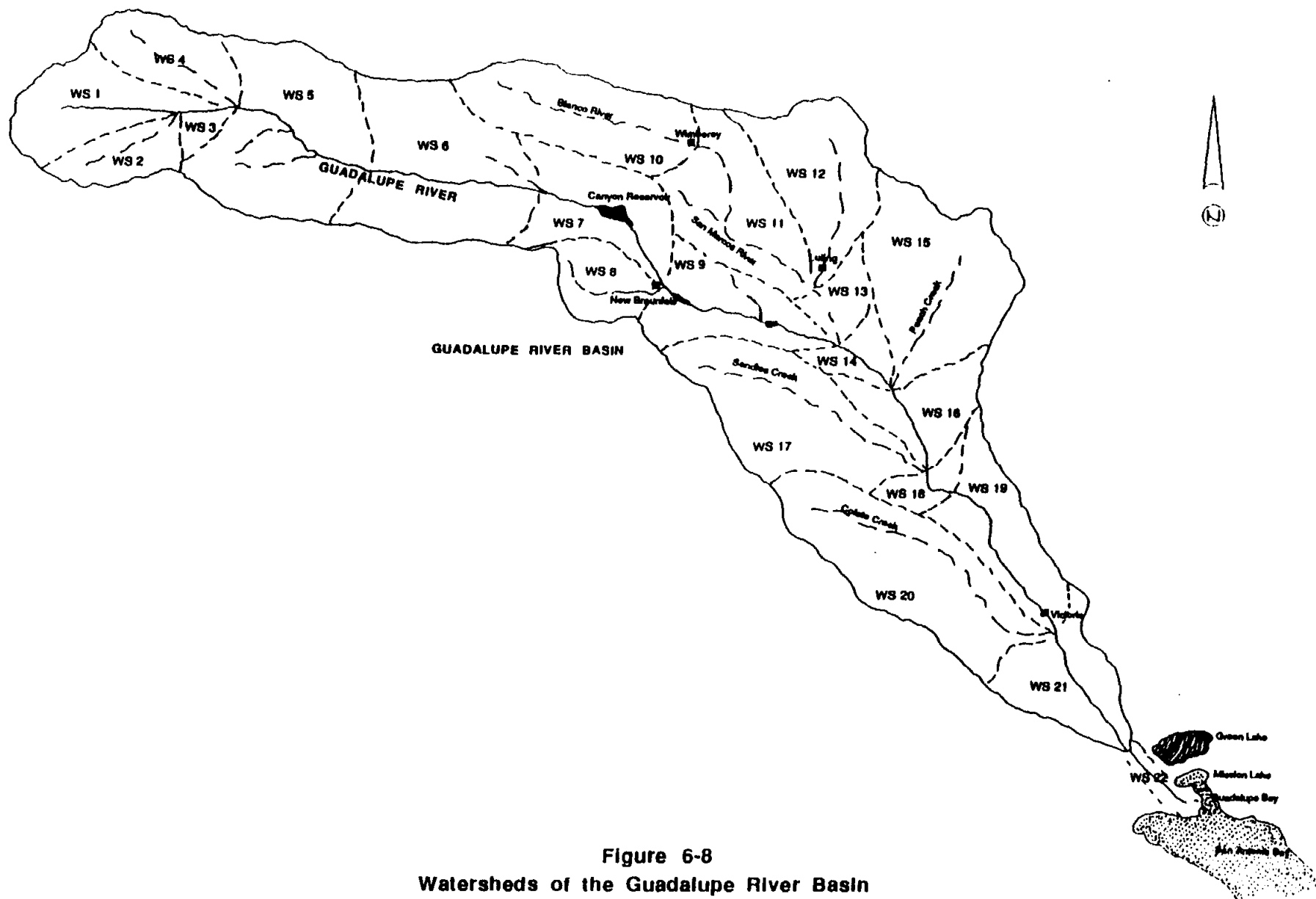

**Figure 6-8**  
**Watersheds of the Guadalupe River Basin**

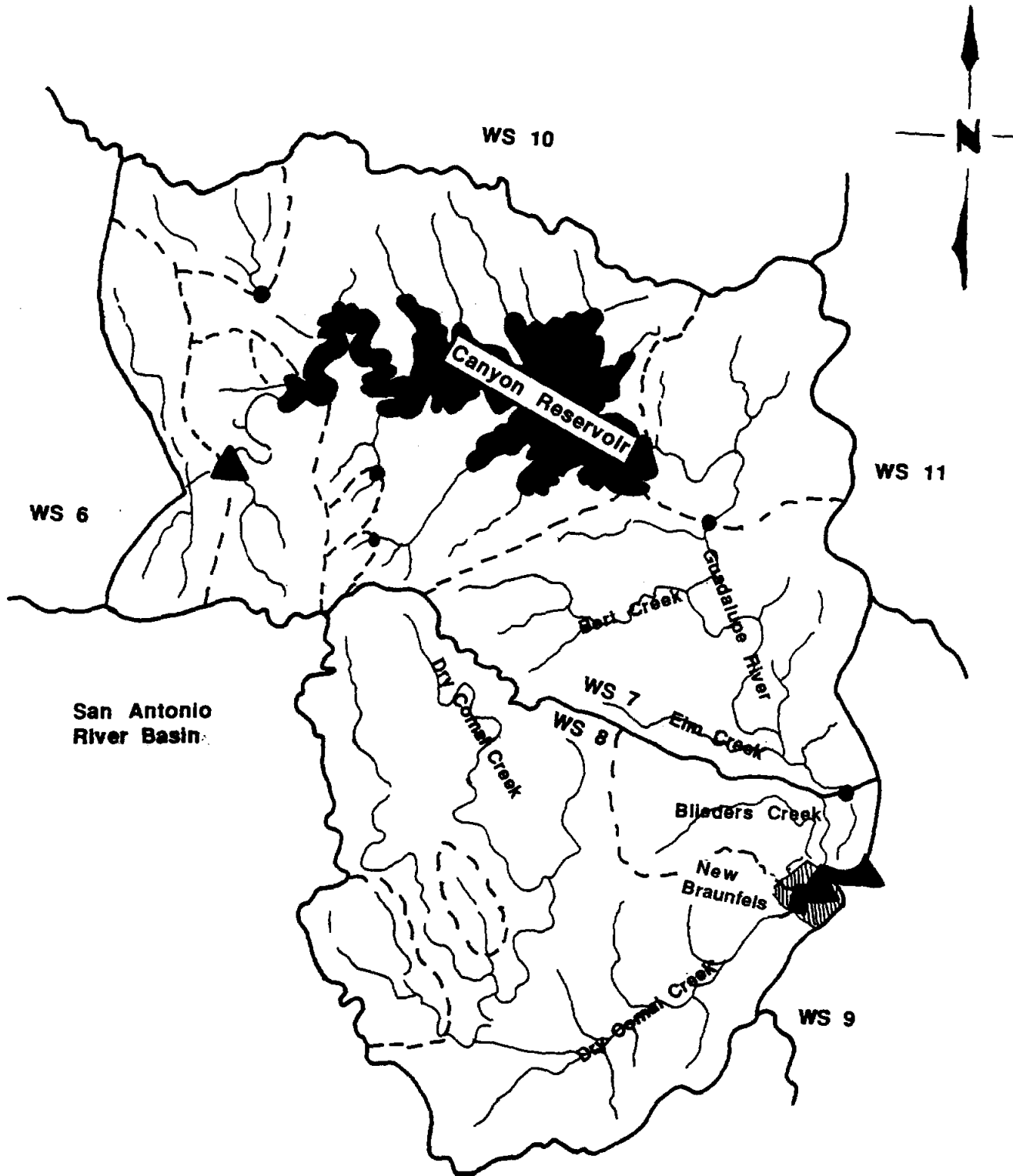

**Figure 6-9**  
**Guadalupe River Basin**  
**Watershed 7 & 8**

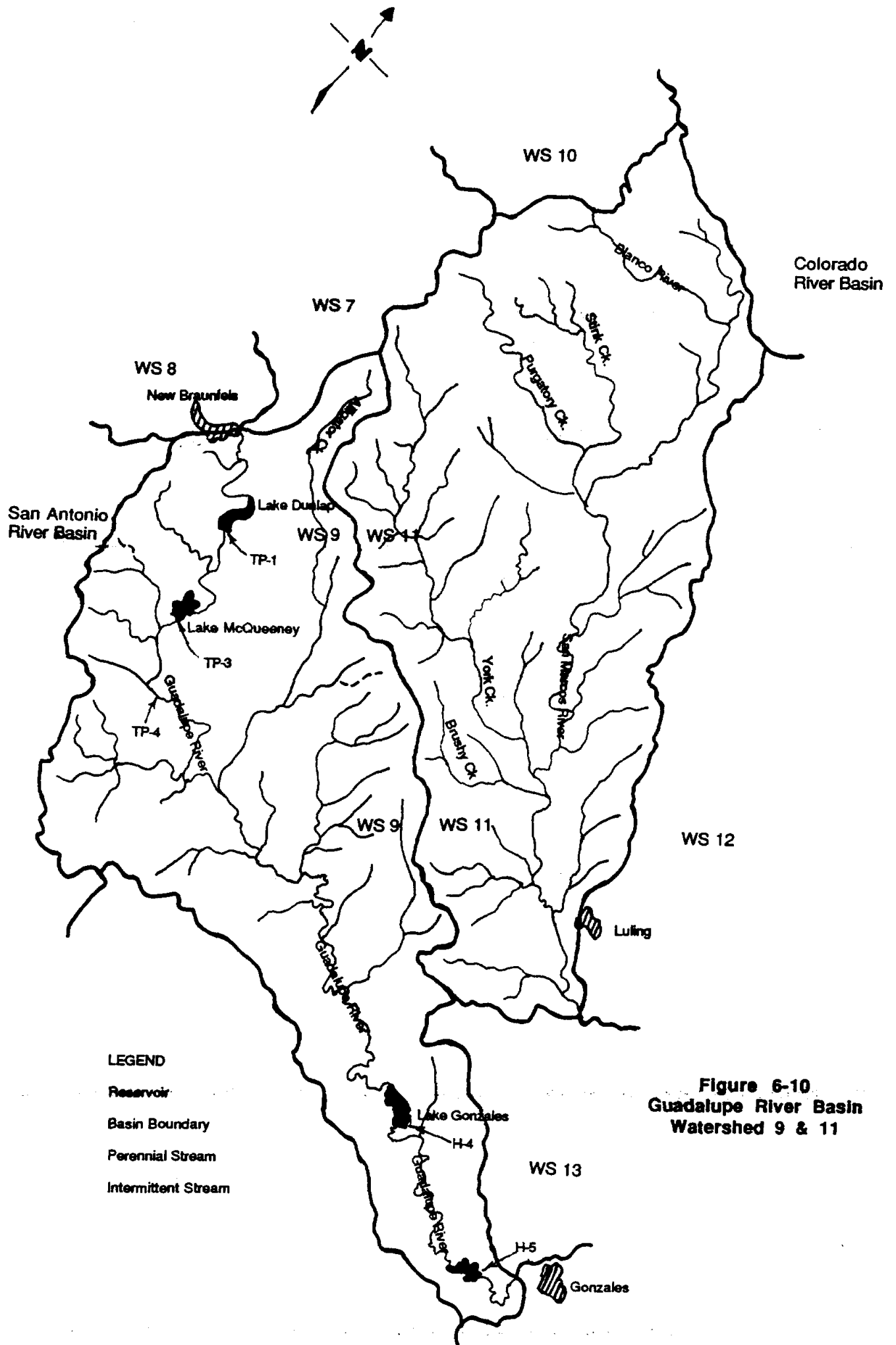

**Table 6-4**  
**Guadalupe River Basin**  
**Estimated Quantities of Unappropriated Surface Water in Acre-Feet**  
**in Watershed 8**

Year	Jan	Feb	Mar	Apr	May	Jun	Jul	Aug	Sept	Oct	Nov	Dec	Total
1940	0,000.	0,000.	0,000.	0,000.	0,000.	0,000.	0,000.	0,000.	0,000.	0,000.	0,000.	0,000.	0,000.
1941	0,000.	1,735.	2,921.	7,128.	10,868.	1,231.	0,000.	0,000.	0,000.	0,000.	0,000.	0,000.	23,885.
1942	0,000.	0,000.	0,000.	0,000.	0,000.	0,000.	0,000.	0,000.	0,152.	5,261.	0,000.	0,000.	5,413.
1943	0,000.	0,000.	0,000.	0,000.	0,000.	0,000.	0,000.	0,000.	0,000.	0,000.	0,000.	0,000.	0,000.
1944	0,000.	0,000.	0,000.	0,000.	0,000.	0,000.	0,000.	0,000.	0,000.	0,000.	0,000.	0,000.	0,000.
1945	2,163.	3,966.	5,230.	4,179.	0,000.	0,000.	0,000.	0,000.	0,000.	0,000.	0,000.	0,000.	15,538.
1946	0,000.	0,000.	0,000.	0,000.	0,000.	0,000.	0,000.	0,000.	0,000.	0,000.	0,000.	0,000.	0,000.
1947	7,584.	1,077.	0,000.	0,000.	0,000.	0,000.	0,000.	0,000.	0,000.	0,000.	0,000.	0,000.	8,661.
1948	0,000.	0,000.	0,000.	0,000.	0,000.	0,000.	0,000.	0,000.	0,000.	0,000.	0,000.	0,000.	0,000.
1949	0,000.	0,000.	0,000.	0,000.	0,000.	0,000.	0,000.	0,000.	0,000.	0,000.	0,000.	0,000.	0,000.
1950	0,000.	0,000.	0,000.	0,000.	0,000.	0,000.	0,000.	0,000.	0,000.	0,000.	0,000.	0,000.	0,000.
1951	0,000.	0,000.	0,000.	0,000.	0,000.	0,000.	0,000.	0,000.	0,000.	0,000.	0,000.	0,000.	0,000.
1952	0,000.	0,000.	0,000.	0,000.	0,000.	0,000.	0,000.	0,000.	0,000.	0,000.	0,000.	0,000.	0,000.
1953	0,000.	0,000.	0,000.	0,000.	0,000.	0,000.	0,000.	0,000.	0,000.	0,000.	0,000.	0,000.	0,000.
1954	0,000.	0,000.	0,000.	0,000.	0,000.	0,000.	0,000.	0,000.	0,000.	0,000.	0,000.	0,000.	0,000.
1955	0,000.	0,000.	0,000.	0,000.	0,000.	0,000.	0,000.	0,000.	0,000.	0,000.	0,000.	0,000.	0,000.
1956	0,000.	0,000.	0,000.	0,000.	0,000.	0,000.	0,000.	0,000.	0,000.	0,000.	0,000.	0,000.	0,000.
1957	0,000.	0,000.	0,000.	0,000.	0,000.	0,000.	0,000.	0,000.	0,000.	0,000.	0,000.	0,000.	0,000.
1958	0,000.	0,000.	0,000.	0,000.	4,910.	0,000.	0,000.	0,000.	0,000.	0,000.	0,000.	0,000.	4,910.
1959	0,000.	0,000.	0,000.	0,000.	0,000.	0,000.	0,000.	0,000.	0,000.	0,000.	0,000.	0,000.	0,000.
1960	0,000.	0,000.	0,000.	0,000.	0,000.	0,000.	0,000.	0,000.	0,000.	6,880.	3,998.	4,397.	15,276.
1961	4,389.	5,472.	1,400.	0,000.	0,000.	0,000.	0,000.	0,000.	0,000.	0,000.	0,000.	0,000.	11,261.
1962	0,000.	0,000.	0,000.	0,000.	0,000.	0,000.	0,000.	0,000.	0,000.	0,000.	0,000.	0,000.	0,000.
1963	0,000.	0,000.	0,000.	0,000.	0,000.	0,000.	0,000.	0,000.	0,000.	0,000.	0,000.	0,000.	0,000.
1964	0,000.	0,000.	0,000.	0,000.	0,000.	0,000.	0,000.	0,000.	0,000.	0,000.	0,000.	0,000.	0,000.
1965	0,000.	0,000.	0,000.	0,000.	0,000.	0,000.	0,000.	0,000.	0,000.	0,000.	0,000.	0,000.	0,000.
1966	0,000.	0,000.	0,000.	0,000.	0,000.	0,000.	0,000.	0,000.	0,000.	0,000.	0,000.	0,000.	0,000.
1967	0,000.	0,000.	0,000.	0,000.	0,000.	0,000.	0,000.	0,000.	0,000.	0,000.	0,000.	0,000.	0,000.
1968	2,147.	6,478.	2,445.	2,135.	1,962.	0,000.	0,000.	0,000.	0,000.	0,000.	0,000.	0,000.	15,166.
1969	0,000.	0,000.	0,000.	0,000.	0,000.	0,000.	0,000.	0,000.	0,000.	0,000.	0,000.	0,000.	0,000.
1970	0,000.	0,000.	0,497.	0,000.	0,342.	0,000.	0,000.	0,000.	0,000.	0,000.	0,000.	0,000.	0,839.
1971	0,000.	0,000.	0,000.	0,000.	0,000.	0,000.	0,000.	0,000.	0,000.	1,495.	1,303.	2,532.	5,330.
1972	0,000.	0,000.	0,000.	0,000.	31,175.	0,180.	0,000.	0,000.	0,000.	0,000.	0,000.	0,000.	31,355.
1973	0,000.	0,000.	0,000.	0,000.	0,000.	0,543.	10,582.	5,818.	5,461.	13,560.	5,036.	0,431.	41,430.
1974	0,000.	0,000.	0,000.	0,000.	0,000.	0,000.	0,000.	0,000.	0,727.	0,000.	3,637.	2,081.	6,645.
1975	0,635.	8,979.	1,852.	0,616.	13,586.	7,591.	3,402.	2,310.	0,000.	0,000.	0,000.	0,000.	38,973.
1976	0,000.	0,000.	0,000.	0,000.	0,000.	0,000.	1,276.	1,164.	0,000.	3,104.	3,914.	4,657.	14,115.
1977	3,390.	2,478.	0,000.	13,320.	7,518.	0,485.	0,000.	0,000.	0,000.	0,000.	0,000.	0,000.	27,191.
1978	0,000.	0,000.	0,000.	0,000.	0,000.	0,000.	0,000.	3,137.	3,245.	0,000.	0,000.	0,000.	6,382.
1979	3,989.	5,366.	7,461.	6,720.	5,621.	7,904.	3,840.	5,144.	0,000.	0,000.	0,000.	0,000.	46,044.
Max	7,584.	8,979.	7,461.	13,320.	31,175.	7,904.	10,582.	5,818.	5,461.	13,560.	5,036.	4,657.	46,044.
Min	0,000.	0,000.	0,000.	0,000.	0,000.	0,000.	0,000.	0,000.	0,000.	0,000.	0,000.	0,000.	0,000.
Mean	0,607.	0,889.	0,545.	0,852.	1,900.	0,448.	0,478.	0,439.	0,240.	0,758.	0,447.	0,352.	7,960.
S.D.	1,594.	2,123.	1,530.	2,615.	5,653.	1,711.	1,831.	1,331.	0,995.	2,521.	1,277.	1,098.	12,797.





Figure 6-12  
Annual Flow Frequency Distribution  
Comal River at New Braunfels  
1963-1988

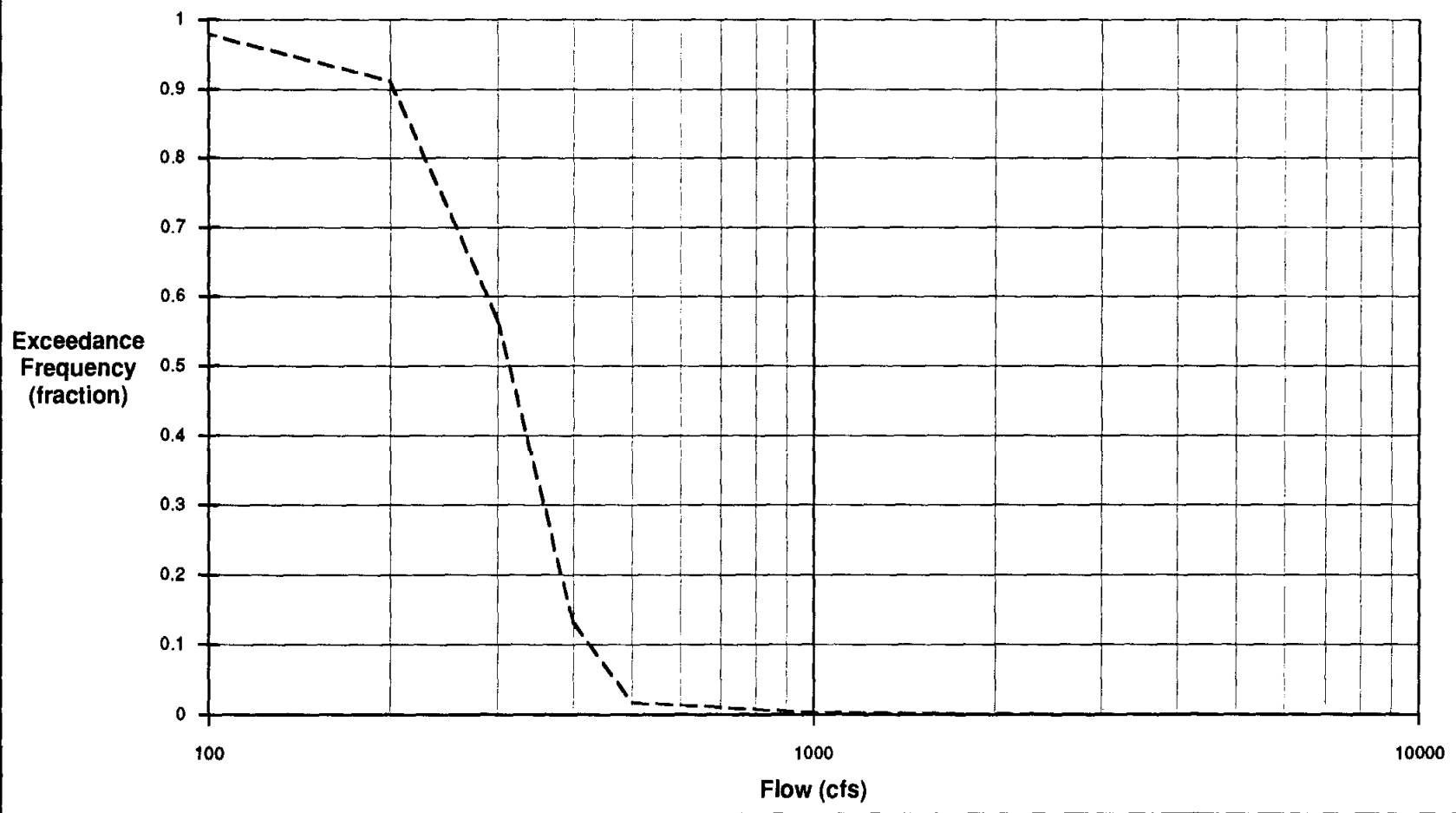



Figure 6-14  
Annual Flow Frequency Distribution  
Guadalupe River above Comal River at New Braunfels  
1963-1988

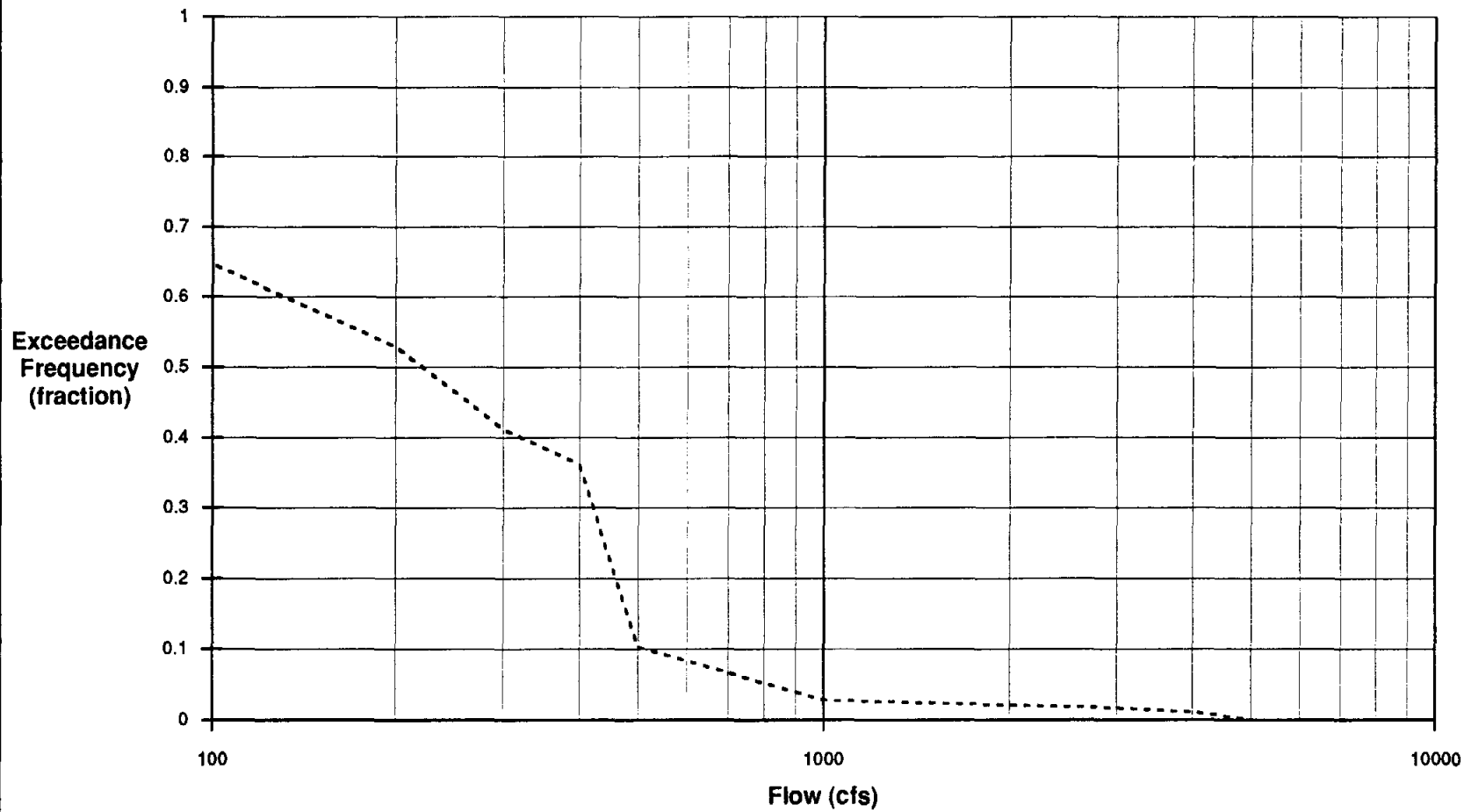

Figure 6-15  
Daily Flow Frequency Distribution  
Combined Guadalupe and Comal Rivers Below New Braunfels  
1963-1988

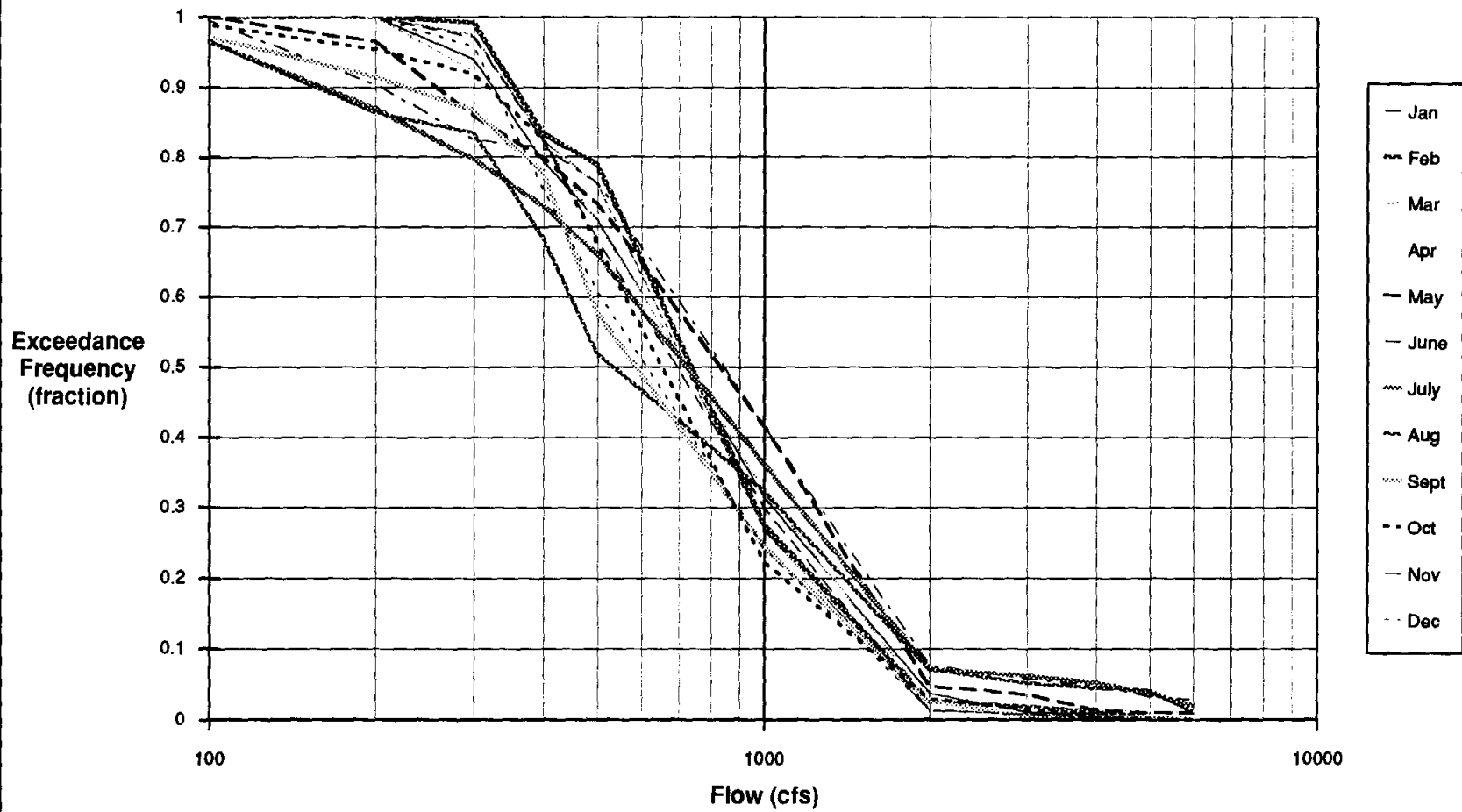
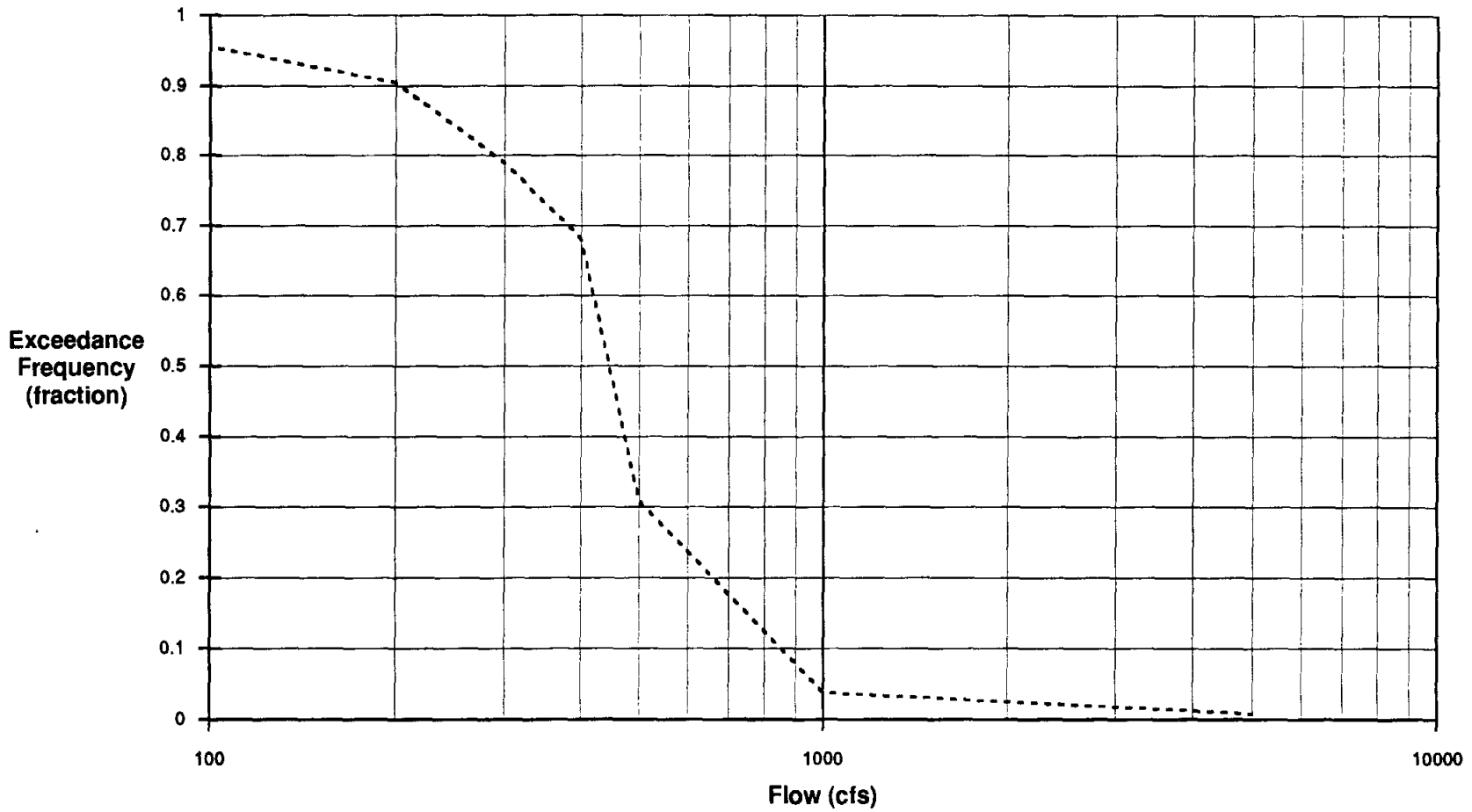

Figure 6-16  
Annual Flow Frequency Distribution  
Combined Guadalupe and Comal Rivers Below New Braunfels  
1963-1988



generation. However, it indicates that on a daily average flow basis, the GBRA or GVEC impoundments are used to generate electric power only 5% of the time.

Inspection of the monthly TWC unappropriated flow data set leaving Watershed 9 (Table 6-5) indicates significant quantities of water available for appropriation. Note that the values in this table already account for all downstream appropriations. Mean monthly available water over the period of record range from 14,646 AF/mo. in August to 49,949 AF/mo. in December. The annual average is 399,691 AF/yr.

From these data, it is apparent that there exists the engineering feasibility for conjunctive use or possible subordination of some of the GBRA's current hydropower rights. GBRA hydrodams H-4 and H-5 could be operated as a reservoir "system" to maximize the firm annual yield. The power generated from pool H-4 to H-5 under normal water supply reservoir operation could be used to off-set the pumping costs necessary to deliver the treated water to the CRWA service area.

#### 6.4.5 Surface Water Appropriation Without Impoundment

##### Guadalupe River Within Service Area

Within the CRWA service area, without conjunctive use or subordination of GBRA hydropower rights there is little possibility of obtaining a surface water appropriation without impoundment. Examination of the TWC unappropriated water data set for Watershed 8 and the monthly daily flow frequency curves for this stretch of the Guadalupe River indicates that as long as the GBRA's minimum flow restrictions of 1,300 cfs remains in effect there is insufficient water on which to build a firm supply for CRWA users. Therefore, this option is being dropped from further consideration.

##### Guadalupe River Other

Examination of the TWC Unappropriated Water Data Set for Watershed 9 indicates the presence of significant quantities of unappropriated water below GBRA hydropower dam H-5. However, without impoundment, the reliability of the supply may be inadequate to serve CRWA as a primary source. The "critical drought" period in Central Texas is generally considered to span the period from January 1951 through February 1957 (62 months). During this period, the TWC Appropriations Model shows 27 months (44%) of zero unappropriated flow below H-5. Therefore, without off-channel storage, this option will not receive further consideration.

##### San Marcos River

Examination of the TWC Unappropriated Water Data set for Watershed 10, inflows to the San Marcos River, Watershed 11 (Table 6-6) indicate an infirm supply without off-channel storage. During the critical

**Table 6-5**  
**Guadalupe River Basin**  
**Estimated Quantities of Unappropriated Surface Water in Acre-Feet**  
**in Watershed 9**

Year	Jan	Feb	Mar	Apr	May	Jun	Jul	Aug	Sept	Oct	Nov	Dec	Total
1940	32,275.	11,345.	13,838.	24,254.	16,931.	28,738.	110,105.	13,018.	5,011.	12,558.	76,280.	49,563.	393,917.
1941	51,812.	60,644.	89,795.	66,845.	169,960.	76,706.	63,690.	27,670.	29,809.	38,006.	41,597.	748,211.	718,211.
1942	27,379.	19,316.	20,147.	50,418.	54,016.	34,290.	76,407.	21,548.	50,911.	67,379.	54,280.	47,266.	523,356.
1943	51,048.	35,594.	31,259.	27,676.	24,648.	35,690.	22,312.	12,172.	15,025.	14,679.	14,337.	16,458.	300,898.
1944	32,951.	40,109.	53,477.	42,322.	54,558.	61,218.	35,312.	17,715.	32,792.	26,225.	26,924.	40,053.	483,655.
1945	49,179.	67,573.	75,114.	84,193.	55,143.	41,345.	20,057.	15,450.	19,833.	36,634.	23,417.	33,173.	521,112.
1946	37,203.	41,794.	55,312.	43,171.	54,721.	46,806.	20,566.	18,609.	40,018.	44,756.	42,226.	38,868.	486,050.
1947	55,221.	61,240.	68,006.	55,896.	59,147.	38,922.	22,836.	22,060.	11,016.	8,632.	14,218.	15,764.	432,959.
1948	17,087.	18,052.	17,555.	9,992.	27,999.	9,255.	12,158.	9,066.	1,809.	5,659.	5,347.	4,458.	138,437.
1949	8,276.	26,375.	41,735.	48,074.	57,846.	33,211.	19,710.	12,303.	8,955.	24,289.	22,750.	21,238.	324,764.
1950	18,285.	18,643.	14,443.	18,628.	20,401.	20,947.	4,067.	0,793.	1,262.	3,991.	4,180.	3,883.	129,523.
1951	6,247.	3,934.	2,989.	1,133.	11,910.	18,499.	0,000.	0,000.	1,716.	1,599.	2,767.	2,733.	53,535.
1952	4,309.	2,476.	0,865.	7,195.	28,761.	17,140.	0,000.	0,000.	33,703.	30,880.	13,818.	35,463.	174,406.
1953	38,352.	16,702.	13,426.	17,681.	36,078.	0,000.	0,000.	3,379.	28,328.	19,530.	11,520.	15,239.	200,236.
1954	11,535.	4,347.	2,634.	1,852.	8,641.	0,000.	0,000.	0,000.	0,000.	0,000.	0,000.	0,519.	29,527.
1955	1,815.	6,175.	0,793.	0,000.	7,195.	3,353.	0,000.	0,000.	0,000.	0,000.	0,000.	0,000.	19,331.
1956	0,417.	0,275.	0,000.	0,000.	0,000.	0,000.	0,000.	0,000.	0,000.	0,000.	0,000.	1,275.	1,967.
1957	1,542.	1,277.	18,474.	46,045.	73,172.	55,106.	27,359.	0,000.	49,280.	43,930.	46,464.	42,958.	396,607.
1958	55,087.	56,500.	65,979.	52,666.	62,306.	53,087.	34,788.	15,112.	31,410.	49,843.	57,262.	46,618.	580,658.
1959	47,978.	49,596.	39,790.	51,798.	42,721.	38,908.	37,642.	17,073.	13,560.	40,296.	40,951.	33,631.	453,943.
1960	41,251.	37,527.	34,810.	37,263.	57,726.	37,523.	47,455.	21,460.	30,051.	43,571.	151,672.	53,970.	594,279.
1961	73,421.	69,079.	68,500.	51,757.	44,260.	51,771.	47,982.	23,857.	34,003.	29,315.	41,772.	28,780.	564,498.
1962	29,421.	22,903.	20,453.	20,203.	17,985.	15,681.	1,018.	0,000.	8,928.	11,200.	14,604.	36,813.	199,209.
1963	16,193.	17,240.	16,023.	14,418.	9,745.	0,000.	0,000.	0,000.	0,000.	0,000.	16,248.	4,145.	90,612.
1964	6,427.	18,937.	27,590.	13,122.	7,006.	10,370.	0,000.	1,362.	27,990.	33,516.	21,684.	9,026.	177,030.
1965	20,515.	51,842.	50,261.	41,189.	53,421.	51,731.	32,986.	15,911.	11,292.	27,362.	36,834.	42,887.	436,232.
1966	47,351.	43,407.	49,860.	45,964.	57,660.	39,608.	18,395.	14,488.	25,578.	26,449.	16,281.	13,547.	399,585.
1967	16,655.	10,012.	11,195.	6,019.	1,984.	0,319.	0,000.	0,137.	54,184.	45,976.	43,117.	40,847.	230,445.
1968	59,301.	71,870.	72,717.	69,945.	106,059.	81,010.	46,031.	19,115.	31,117.	24,883.	24,513.	37,112.	643,677.
1969	30,133.	52,012.	57,771.	56,000.	58,158.	42,632.	19,045.	14,302.	19,266.	37,127.	48,909.	57,738.	493,094.
1970	59,913.	45,324.	61,808.	55,434.	52,167.	65,451.	36,522.	22,409.	266,278.	23,490.	22,040.	23,788.	494,972.
1971	23,184.	18,526.	18,900.	15,205.	6,578.	4,076.	0,351.	13,930.	45,672.	52,066.	46,005.	52,583.	299,133.
1972	58,467.	49,374.	42,976.	27,368.	132,400.	69,903.	47,518.	31,841.	39,445.	38,814.	36,146.	32,439.	606,691.
1973	39,410.	45,954.	57,368.	54,204.	57,413.	71,022.	49,377.	42,938.	53,148.	118,654.	58,695.	60,068.	708,254.
1974	46,243.	51,968.	55,627.	43,269.	55,647.	48,276.	30,066.	22,564.	40,708.	52,762.	41,292.	62,046.	550,669.
1975	61,698.	50,638.	69,150.	61,029.	73,261.	74,895.	60,126.	35,695.	46,948.	43,548.	42,851.	37,728.	657,560.
1976	31,623.	28,457.	30,037.	51,591.	73,991.	53,165.	53,877.	30,004.	45,718.	42,230.	93,831.	96,294.	630,818.
1977	61,220.	73,678.	66,349.	49,196.	91,789.	63,172.	49,231.	32,244.	41,434.	42,199.	46,156.	38,390.	655,062.
1978	35,526.	33,894.	35,368.	36,565.	27,351.	40,525.	15,129.	0,000.	62,370.	54,239.	60,477.	45,209.	446,644.
1979	74,402.	64,607.	57,024.	72,529.	109,787.	118,171.	54,902.	37,377.	50,809.	44,662.	34,614.	27,191.	746,073.
Max	74,402.	73,678.	89,795.	84,193.	169,960.	118,171.	110,105.	42,938.	266,278.	118,654.	151,672.	748,211.	746,073.
Min	0,417.	0,275.	0,000.	0,000.	0,000.	0,000.	0,000.	0,000.	0,000.	0,000.	0,000.	0,000.	1,967.
Mean	34,504.	34,980.	38,231.	36,803.	49,014.	38,863.	27,951.	14,640.	32,734.	31,524.	34,902.	49,949.	399,691.
S.D.	21,057.	22,205.	24,908.	22,506.	36,672.	27,458.	25,524.	12,262.	42,116.	22,826.	28,689.	115,134.	216,358.

**Table 6-6**  
**Guadalupe River Basin**  
**Estimated Quantities of Unappropriated Surface Water in Acre-Feet**  
**In Watershed 11**

Year	Jan	Feb	Mar	Apr	May	Jun	Jul	Aug	Sept	Oct	Nov	Dec	Total
1940	5,460.	4,118.	3,447.	4,804.	3,788.	27,542.	6,905.	2,889.	1,615.	4,938.	21,251.	39,242.	125,999.
1941	18,887.	15,230.	22,231.	61,353.	43,896.	28,895.	21,523.	13,936.	9,521.	12,670.	9,681.	9,633.	265,455.
1942	9,330.	5,688.	5,817.	9,577.	8,625.	6,145.	55,261.	5,365.	58,936.	38,251.	18,439.	15,769.	237,205.
1943	13,780.	11,324.	11,421.	7,345.	8,344.	8,779.	5,099.	3,649.	4,913.	4,852.	6,093.	6,649.	92,249.
1944	13,744.	11,794.	30,348.	17,344.	35,078.	23,429.	14,663.	9,255.	10,778.	8,851.	13,949.	22,114.	211,347.
1945	28,367.	28,830.	39,370.	36,611.	16,178.	11,026.	6,199.	6,208.	5,135.	8,949.	7,274.	6,473.	200,622.
1946	13,534.	14,176.	24,249.	14,852.	12,943.	15,240.	5,080.	11,998.	28,948.	15,186.	26,532.	24,055.	206,792.
1947	33,167.	24,940.	22,425.	20,565.	17,275.	10,443.	6,287.	20,186.	4,410.	4,225.	5,453.	5,251.	175,328.
1948	6,519.	6,796.	6,282.	2,854.	6,721.	1,827.	2,481.	3,186.	0,703.	2,649.	2,202.	1,848.	44,068.
1949	3,821.	14,137.	6,500.	53,260.	10,892.	7,824.	4,687.	2,975.	2,453.	40,715.	6,850.	7,257.	161,373.
1950	6,709.	7,816.	5,271.	12,563.	4,746.	22,705.	1,068.	0,347.	0,556.	1,561.	1,759.	1,598.	66,698.
1951	2,704.	1,813.	1,258.	0,437.	2,589.	18,322.	0,000.	0,000.	0,883.	0,842.	1,528.	1,396.	31,770.
1952	2,278.	1,303.	0,342.	1,737.	8,810.	4,874.	0,000.	0,000.	5,075.	5,921.	10,472.	14,183.	54,997.
1953	11,876.	6,794.	4,185.	29,732.	8,189.	0,000.	0,000.	2,058.	6,419.	11,297.	6,523.	13,851.	100,924.
1954	7,783.	3,493.	2,297.	1,576.	6,344.	0,000.	0,000.	0,000.	0,000.	0,000.	0,000.	0,399.	21,893.
1955	1,213.	6,496.	0,685.	0,000.	4,074.	4,622.	0,000.	0,000.	0,000.	0,000.	0,000.	0,000.	17,070.
1956	0,433.	0,306.	0,000.	0,000.	0,000.	0,000.	0,000.	0,000.	0,000.	0,000.	0,000.	1,366.	2,104.
1957	13,376.	8,816.	25,641.	7,911.	37,116.	28,942.	1,476.	0,000.	3,782.	68,404.	25,611.	21,100.	242,175.
1958	26,422.	65,260.	27,987.	24,682.	32,476.	14,398.	9,891.	5,724.	15,598.	18,542.	20,192.	17,555.	280,745.
1959	14,449.	14,585.	12,851.	27,073.	15,374.	9,316.	9,042.	5,798.	4,104.	21,035.	15,365.	10,699.	159,692.
1960	14,865.	13,311.	12,272.	39,291.	14,711.	66,538.	12,627.	9,441.	8,564.	41,418.	28,534.	28,775.	290,346.
1961	32,758.	24,994.	22,474.	16,871.	12,646.	31,500.	12,848.	9,968.	8,317.	8,937.	16,696.	10,083.	208,392.
1962	9,109.	7,422.	6,280.	5,940.	4,238.	3,391.	0,405.	0,000.	5,333.	6,914.	6,450.	8,846.	64,419.
1963	8,050.	9,034.	5,787.	3,811.	3,210.	0,000.	0,000.	0,000.	0,000.	0,000.	0,000.	0,000.	38,081.
1964	3,739.	5,132.	6,298.	3,397.	2,085.	3,957.	0,000.	0,525.	4,720.	4,985.	6,885.	3,452.	45,175.
1965	18,064.	42,008.	17,824.	16,306.	43,804.	32,986.	10,363.	6,165.	4,037.	7,496.	10,250.	28,554.	237,880.
1966	14,618.	14,567.	14,251.	11,642.	13,130.	10,804.	4,796.	3,978.	4,554.	7,786.	5,247.	4,850.	110,224.
1967	5,814.	3,409.	3,551.	1,822.	0,935.	0,100.	0,000.	0,067.	22,131.	8,095.	23,581.	9,670.	79,177.
1968	69,996.	23,555.	23,123.	35,708.	21,844.	19,525.	12,597.	8,162.	9,951.	8,335.	12,001.	17,852.	262,648.
1969	10,102.	20,932.	19,603.	24,834.	29,235.	15,342.	6,867.	5,335.	5,819.	7,503.	8,310.	12,824.	166,706.
1970	10,506.	12,586.	19,440.	15,276.	65,416.	25,830.	14,005.	12,340.	10,948.	14,853.	10,812.	9,730.	221,523.
1971	8,958.	7,388.	6,888.	5,235.	3,614.	1,980.	0,174.	3,562.	7,673.	4,228.	8,202.	13,675.	69,774.
1972	10,873.	9,153.	8,234.	6,901.	92,546.	18,408.	9,387.	8,947.	6,714.	7,418.	6,336.	8,254.	195,177.
1973	10,684.	14,131.	21,644.	26,654.	15,755.	31,424.	23,564.	18,808.	23,739.	68,991.	27,952.	20,017.	305,764.
1974	22,254.	14,038.	13,226.	11,377.	20,786.	12,445.	7,033.	9,883.	38,035.	11,454.	73,855.	10,954.	264,677.
1975	20,003.	28,322.	18,243.	15,331.	96,646.	43,287.	27,139.	19,910.	12,703.	12,333.	10,258.	30,954.	315,129.
1976	9,626.	8,174.	7,909.	33,775.	61,815.	36,650.	21,687.	14,604.	12,493.	52,682.	43,328.	36,922.	341,464.
1977	33,033.	37,573.	25,494.	61,724.	31,457.	19,897.	12,941.	10,321.	9,015.	8,524.	10,679.	9,195.	269,659.
1978	9,209.	8,455.	8,132.	6,253.	5,637.	5,817.	2,730.	4,291.	4,434.	5,972.	14,063.	11,256.	86,250.
1979	28,536.	19,124.	22,614.	42,125.	33,380.	17,404.	15,033.	15,984.	10,586.	9,246.	8,942.	7,470.	230,445.
Max	69,996.	65,260.	39,370.	61,724.	96,646.	66,538.	55,261.	20,186.	58,936.	68,991.	73,855.	39,242.	341,464.
Min	0,433.	0,306.	0,000.	0,000.	0,000.	0,000.	0,000.	0,000.	0,000.	0,000.	0,000.	0,000.	2,104.
Mean	15,818.	15,580.	13,739.	17,853.	22,628.	16,293.	9,270.	6,481.	10,530.	15,436.	14,459.	12,456.	161,338.
S.D.	15,481.	14,954.	10,600.	16,834.	26,051.	16,246.	10,400.	6,320.	11,433.	19,193.	16,691.	10,286.	103,153.



drought period, there were 27 months (44%) with zero unappropriated flow. Therefore, without off-channel storage, this option will not receive further consideration.

#### 6.4.6 Surface Water Appropriation With Impoundment

##### Guadalupe River Within Service Area

Re-examination of the TWC Unappropriated Water Data set for Watershed 8, inflows to the Guadalupe River within the CRWA service area Watershed 9 indicate a totally infirm and inadequate unappropriated water supply. During the critical drought period, there were 62 months (100%) with zero unappropriated flow. Therefore, this option will not receive further consideration.

##### Guadalupe River Other

Below GBRA hydropower dam H-5, there are sufficient quantities of unappropriated service water to make appropriation a viable source option. However, the relatively non-firm supply of unappropriated supplies during the critical drought period, mandates development of in-channel or off-channel storage capabilities if this is to be considered a viable firm supply option. In addition, the relatively long development periods associated with permit acquisition, dam design and construction, as well as the high costs associated with impoundment construction, limits the viability of large scale appropriation below H-5 with impoundment, to a long-term option. Therefore, the recommendation under this option is:

- Short-term Option

- Continue to supply existing demands from existing supplies (including withdrawals from the Edwards Aquifer) to the maximum extent and duration allowed under existing permits, agreements and supply contracts. Supplement supplies with appropriation of small quantities of currently unappropriated Guadalupe water downstream of GBRA hydropower dam H-5 and flood flows pumped to off-channel storage impoundments constructed on major or minor tributaries, natural surface depressions or constructed impoundments.

- Long-term Option

- a. Continue to supply existing demands from existing supplies (including withdrawals from the Edwards Aquifer) to the maximum extent and duration allowed under existing permits, agreements and supply contracts. Supplement supplies with appropriation of large quantities of currently unappropriated Guadalupe water downstream of GBRA hydropower dam H-5 and flood flows pumped to off-channel storage impoundments constructed on major or minor tributaries, natural surface depressions or constructed impoundments.

- b. Reduce or eliminate pumpage from the Edwards Aquifer and supply all demands with appropriation of currently unappropriated Guadalupe water and flood flows pumped to off-channel storage impoundments constructed on major or minor tributaries, natural surface depressions or constructed impoundments.

#### San Marcos River

The San Marcos River is not a viable source of firm CRWA supply without on-channel or off-channel storage. The relatively long development periods associated with permit acquisition and dam design and construction, plus the high costs associated with impoundment construction, limits the viability of appropriation in the San Marcos Basin to a long-term option. Therefore, the recommendation under this option is:

- Short-term Option

Continue to supply existing demands from existing supplies (including withdrawals from the Edwards Aquifer) to the maximum extent and duration allowed under existing permits, agreements and supply contracts. Supplement supplies with appropriation of small quantities of currently unappropriated San Marcos River water and flood flows pumped to off-channel storage impoundments constructed on major or minor tributaries, natural surface depressions or constructed impoundments.

- Long-term Option

- a. Continue to supply existing demands from existing supplies (including withdrawals from the Edwards Aquifer) to the maximum extent and duration allowed under existing permits, agreements and supply contracts. Supplement supplies with appropriation of large quantities of currently unappropriated San Marcos River water and flood flows pumped to off-channel storage impoundments constructed on major or minor tributaries, natural surface depressions or constructed impoundments.

- b. Reduce or eliminate pumpage from the Edwards Aquifer and supply all demands with appropriation of currently unappropriated San Marcos water and flood flows pumped to off-channel storage impoundments constructed on major or minor tributaries, natural surface depressions or constructed impoundments.

#### 6.4.7 Transfer of Coastal Basin Demands

The majority of dedicated releases from Canyon Reservoir, exclusive of releases necessary to fulfill GBRA's own hydropower generation requirements, are to satisfy contractual water supply and obligations

CANYON REGIONAL WATER SUPPLY STUDY  
PRELIMINARY WATER SUPPLY OPTION EVALUATION

in the Lavaca-Guadalupe and San Antonio-Nueces Coastal Basins. The City of Port Lavaca and others purchase their municipal and industrial supplies from the GBRA's Canyon Reservoir storage. The distance between Canyon Reservoir and Calhoun County is well over 150 river miles. The inefficiencies involved in such a system are incredible and the channel losses are sure to be huge.

The Lavaca-Navidad River Authority (LNRA) holds a Texas Permit to provide, for municipal and industrial purposes, up to 75,000 AF/yr from storage in Lake Texana located in southern Jackson County. Formosa Plastics, Inc. located on Lavaca Bay in Point Comfort, Texas, has registered an intent to purchase up to 40,000 AF/yr of that supply. A pipeline between the Palmetto Bend Dam and Point Comfort to deliver these supplies to Formosa Plastics is currently under design. To qualify for tax-exempt bonding status, this pipeline is being oversized by 25% to accommodate potential municipal users. The City of Port Lavaca is located directly across Lavaca Bay from Point Comfort. Thus, Port Lavaca and other cities and industries in the Lavaca-Guadalupe Coastal Basin are prime candidates to switch to Lake Texana as a supply source. The logic of such a switch is that it would save the channel losses inherent in the system between Canyon Reservoir and Calhoun County and would save additional water through the improved operational efficiency.

Transfer of coastal basin municipal and industrial water rights currently served by Guadalupe River flows or dedicated Canyon Reservoir Releases to other local sources, like Lake Texana, is not viable as a short-term option. The lead time necessary to construct the pipeline from Lake Texana will be relatively long and Formosa Plastics has not started construction of their expanded facility. Therefore, the possible long-term option is:

Use Lake Texana water to satisfy water rights and purchase contracts within the Lavaca-Guadalupe Coastal Basin currently supplied by appropriation within the Guadalupe Basin or dedicated contractual releases from Canyon Reservoir. Appropriate or purchase possible increases in unappropriated water in either the Guadalupe or San Marcos Rivers in or near CRWA service area.

Improve Coastal Canal System

The majority of water rights served in the Lavaca-Guadalupe and San Antonio-Nueces Coastal Basins receive their appropriation through the Coastal Canal system. The canal system runs parallel to the coastline and serves as a central distribution system. The Coastal Canal System is, however, very inefficient; and, channel losses through infiltration and bank storage are significant. If the canal losses could be reduced either by lining of the canals or total replacement with an enclosed conduit, that savings would, theoretically, become available for appropriation at some other point in the basin. The magnitude of such a project necessarily precludes it from consideration as a short term option to CRWA. The long-term option then becomes:

Use Lake Texana water to satisfy water rights and purchase contracts within the Lavaca-Guadalupe Coastal Basin currently supplied by appropriation within the Guadalupe Basin or dedicated contractual releases from Canyon Reservoir. Appropriate or purchase possible increases in unappropriated water in either the Guadalupe or San Marcos Rivers in or near CRWA service area.

#### 6.4.8 Recharge of Local Ground Water Formations

Recharging of local groundwater formations is a form of short-term water-banking through creation of underground reservoirs in appropriate local water bearing formations. Candidate formations must be either confined or be a relatively tight formation that will limit migration too far from the point of entry. Their function is to serve as temporary storage to increase the firm annual yield of fluctuating sources. The only candidate formation for recharge in or near the CRWA service area is the Carrizo Sands in northern Wilson County. These sands can accept relatively large quantities of recharge and will function well as a short-term reservoir. However, as there are currently no regulations on pumping from underground formation not regulated by specially formulated districts, the recharged water would be fair-game for anyone in the area. In order to control the resource, the CRWA would need to control (preferably through ownership) all of the surface acreage above the recharge formation.

#### 6.4.9 Wastewater Reuse

Wastewater reuse is an effective and increasingly popular method of reducing overall system-water demands and effectively promoting water conservation. The problem with any wastewater reuse system is that you need a wastewater supply. The vast majority of CRWA customers rely on some type of on-site wastewater disposal system, principally septic tanks. Very few of CRWA's water customers are served by any sort of centralized collection and treatment system that would be conducive to a wastewater reuse system. Therefore, as there is no source of supply, this option will be dropped from further consideration.

### 6.5 Supply Option Matrix Evaluation

#### 6.5.1 Limited/No Action Alternative

##### No Action Alternative

The limited "No Action" Alternative offers by far the simplest engineering approach to solving CRWA's future water supply problems. The engineering necessary to implement this option will consist of construction of interconnects between the four WSCs in order to facilitate transfer of available supplies to areas of demand. The firmness of supply of the No Action Alternative, however, leaves a little to be desired.

CANYON REGIONAL WATER SUPPLY STUDY  
PRELIMINARY WATER SUPPLY OPTION EVALUATION

Assuming a best case development scenario, the first major supply augmentation required by CRWA members would not occur until the year 2005 (Figures 6-17 and 6-18). This is approximately 15 years from the starting planning date, so that the No Action Alternative under the best case scenario would seem to be a reasonable alternative. Under the probable case scenario CRWA will need at least 2 MGD of additional supply by the year 2000 (Figures 6-19 and 6-20). Therefore the No Action Alternative will still be a reasonable alternative for the next 10 years. However, if as assumed in the worst case scenario the Edwards Underground District either limits pumpage or asks users not located directly over the Edwards Aquifer to find alternative sources, then approximately 4 MGD of additional capacity in supply would be necessary in the year 1995 (Figures 6-21 and 6-22). A similar situation would occur if a severe drought occurred and the Edwards Underground District restricts pumpage to some fraction of the 1984 maximum diversion rate for all users. Thus, even as a short-term supply option the No Action Alternative is relatively non-firm (Figures 6-23 and 6-24).

The No Action Alternative offers a very flexible operation in that the only system modifications necessary would be interconnects between four WSCs. In the short-term, it does not appear that there would be any serious environmental harm from continued Edwards Aquifer pumpage.

In the long-term, there would not be any unnecessary engineering activities under any of the other potential development alternatives. However, examination of Figure 6-25 shows that in the long-term the No Action Alternative is not feasible because the supplies required to meet the future growth demands of the CRWA members outstrips available supply about the year 2000 under the probable development scenario and as early as 1995 under the drought condition scenarios. Therefore, the No Action Alternative is relatively infeasible as a long-term option.

Limited Action Alternative

The Limited Action Alternative would involve approaching the Edwards Underground District with a request for additional permitted diversions from the Aquifer. In the short-term, the firmness of supply would not be much better than under the No Action Alternative as it is unlikely that the Edwards would allow the additional 4 MGD of diversion necessary to satisfy demands under a worst case development scenario. In addition, in the long-term such supplies would also be relatively infirm as it has been demonstrated that under drought conditions the finite quantities of water available in the Edwards Aquifer would be severely limited and may not be sufficient to satisfy demands. Flexibility would be the same as the No Action Alternative; however additional wells into the Edwards Aquifer in the short and long-term may have negative impacts on this increasingly stressed water source.

**Figure 6-17**  
**Best Case Projected CRWA Member Future Water**  
**Demand and Supplies - No Action Alternative**

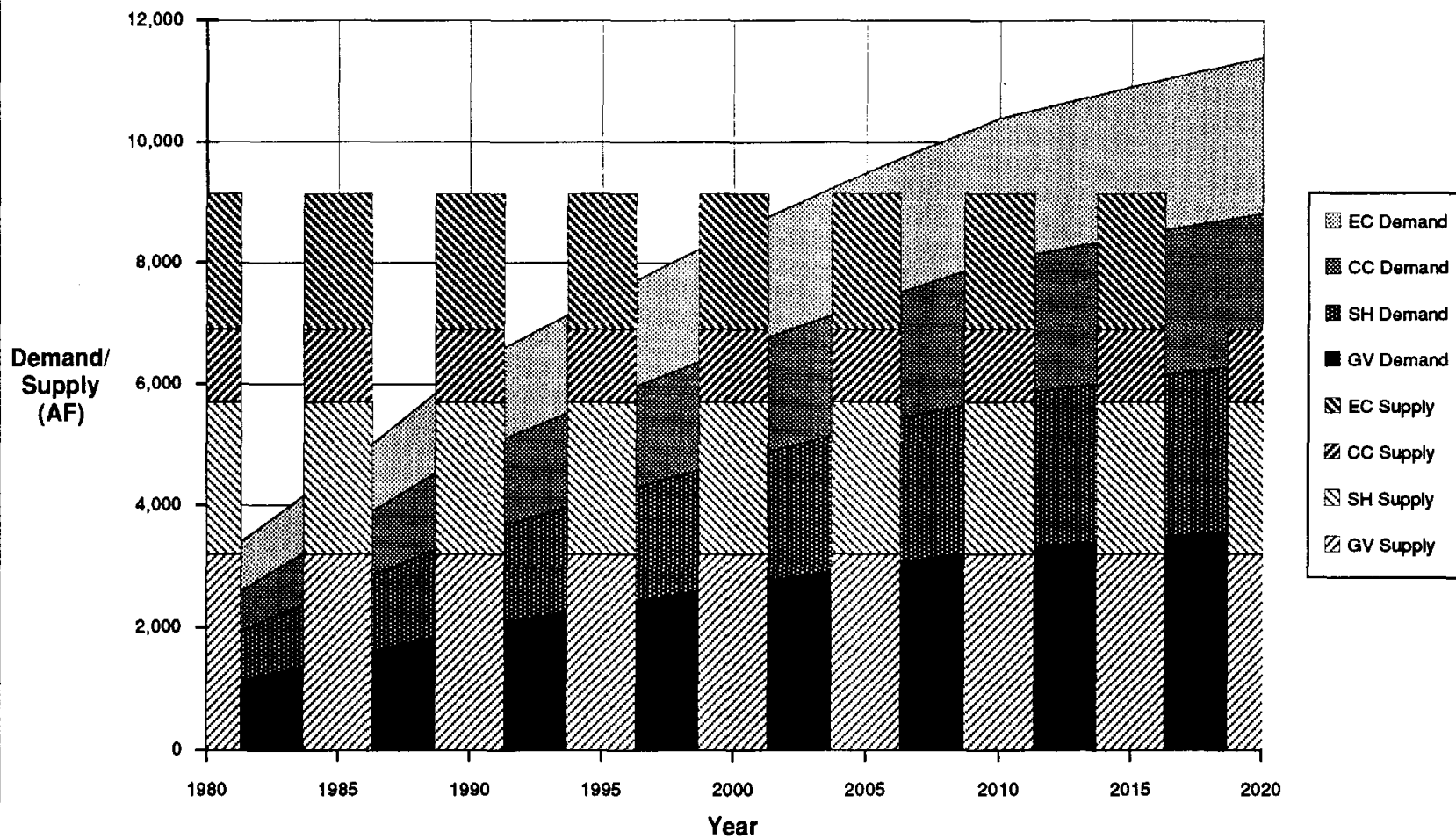

**Figure 6-18**  
**Best Case Projected CRWA Member Future Water**  
**Demand and Required Supplemental Supplies**

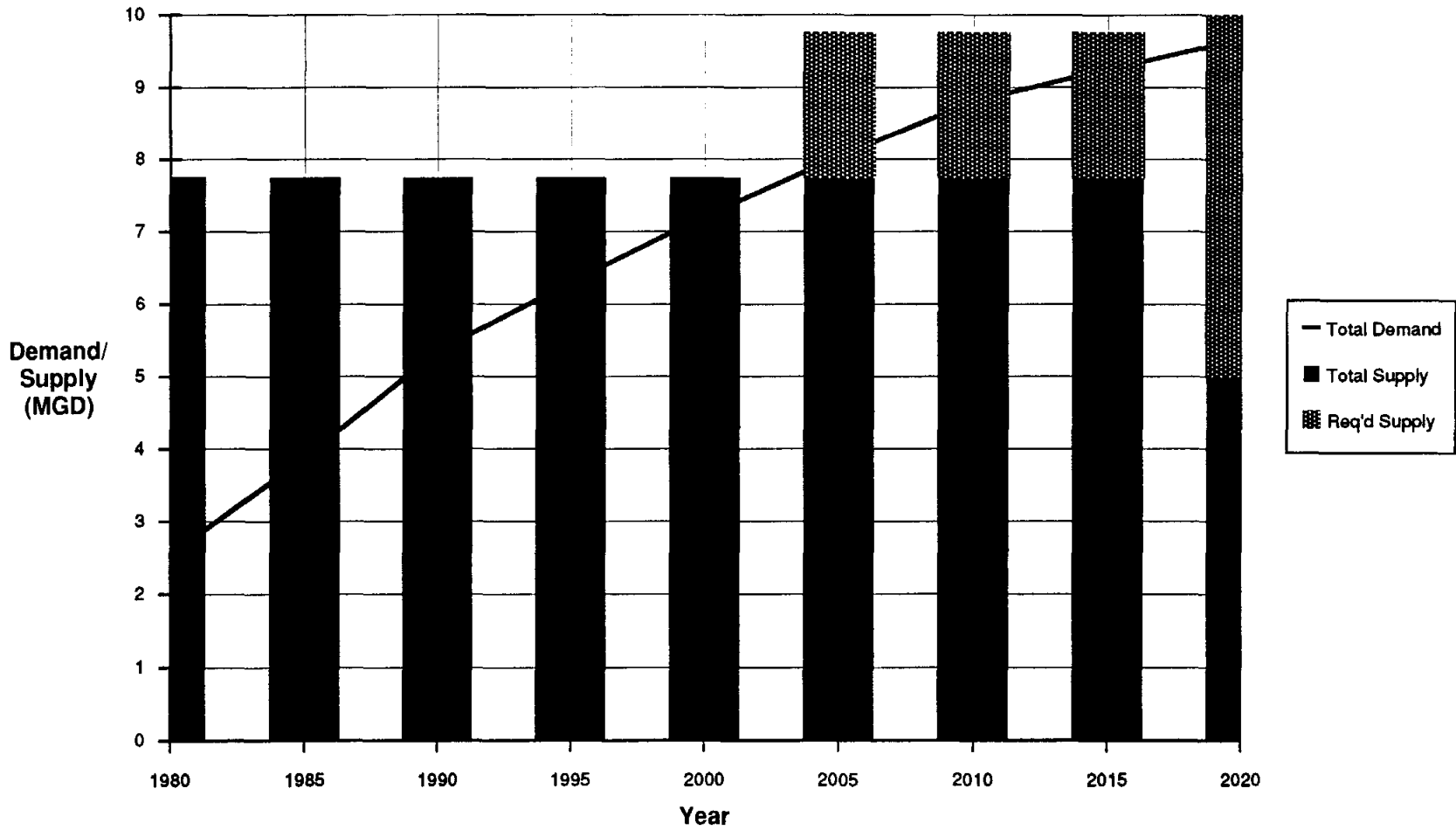

Figure 6-19  
 Probable Case Projected CRWA Member Future Water  
 Demand and Supplies - No Action Alternative

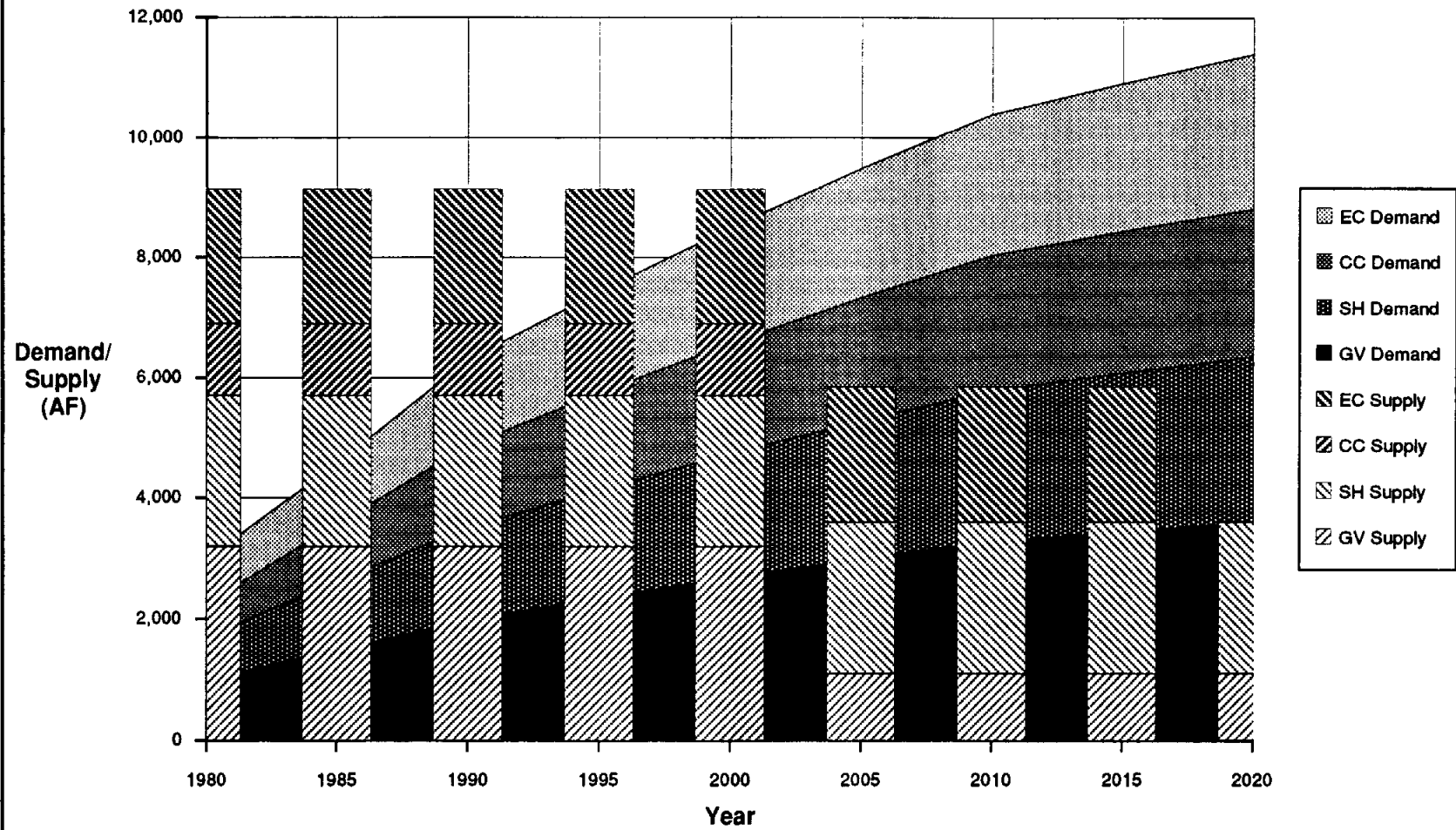
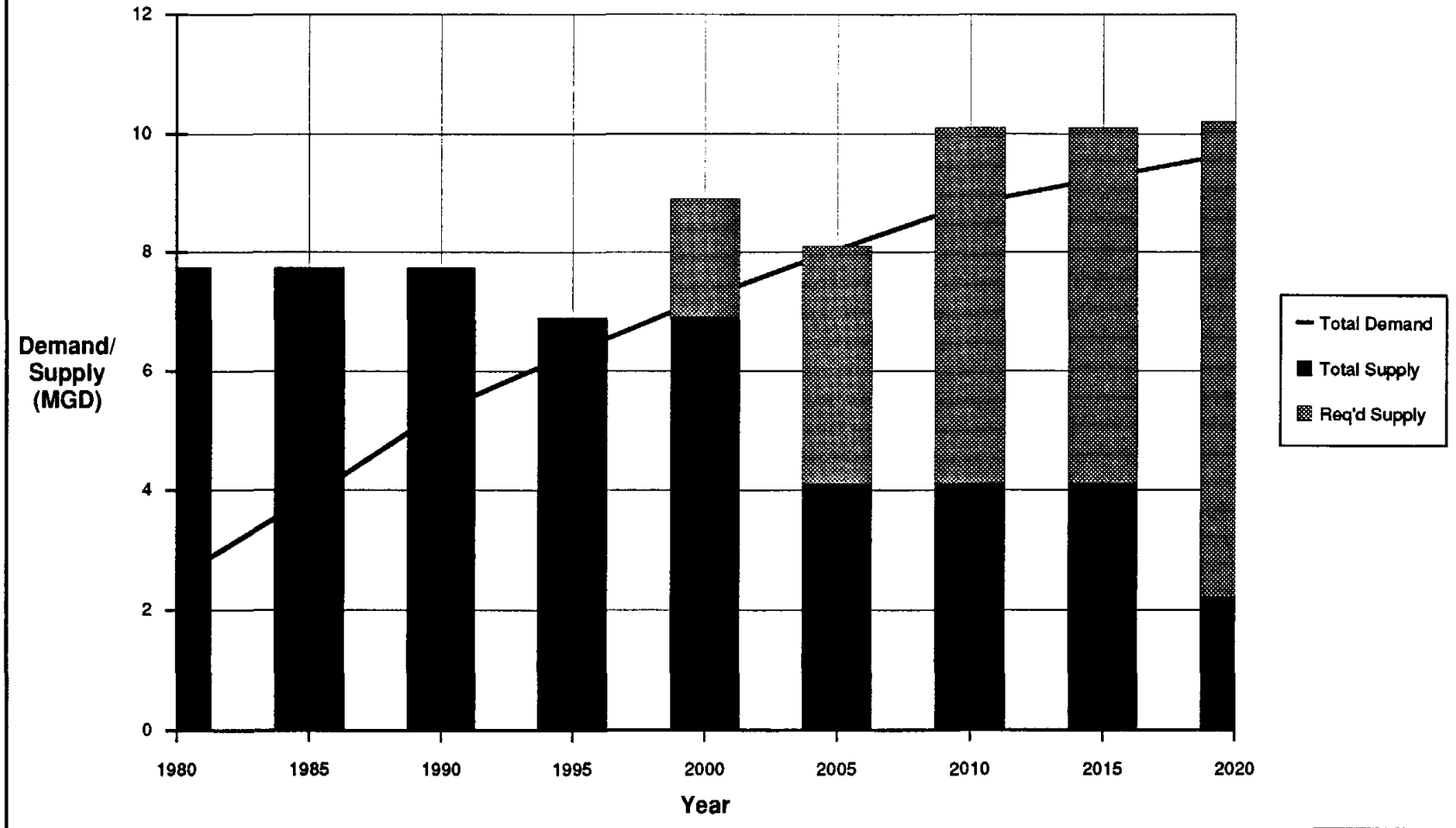



Figure 6-20  
Probable Case Projected CRWA Member Future Water  
Demand and Required Supplemental Supplies



**Figure 6-21**  
**Worst Case Projected CRWA Member Future Water**  
**Demand and Supplies - No Action Alternative**

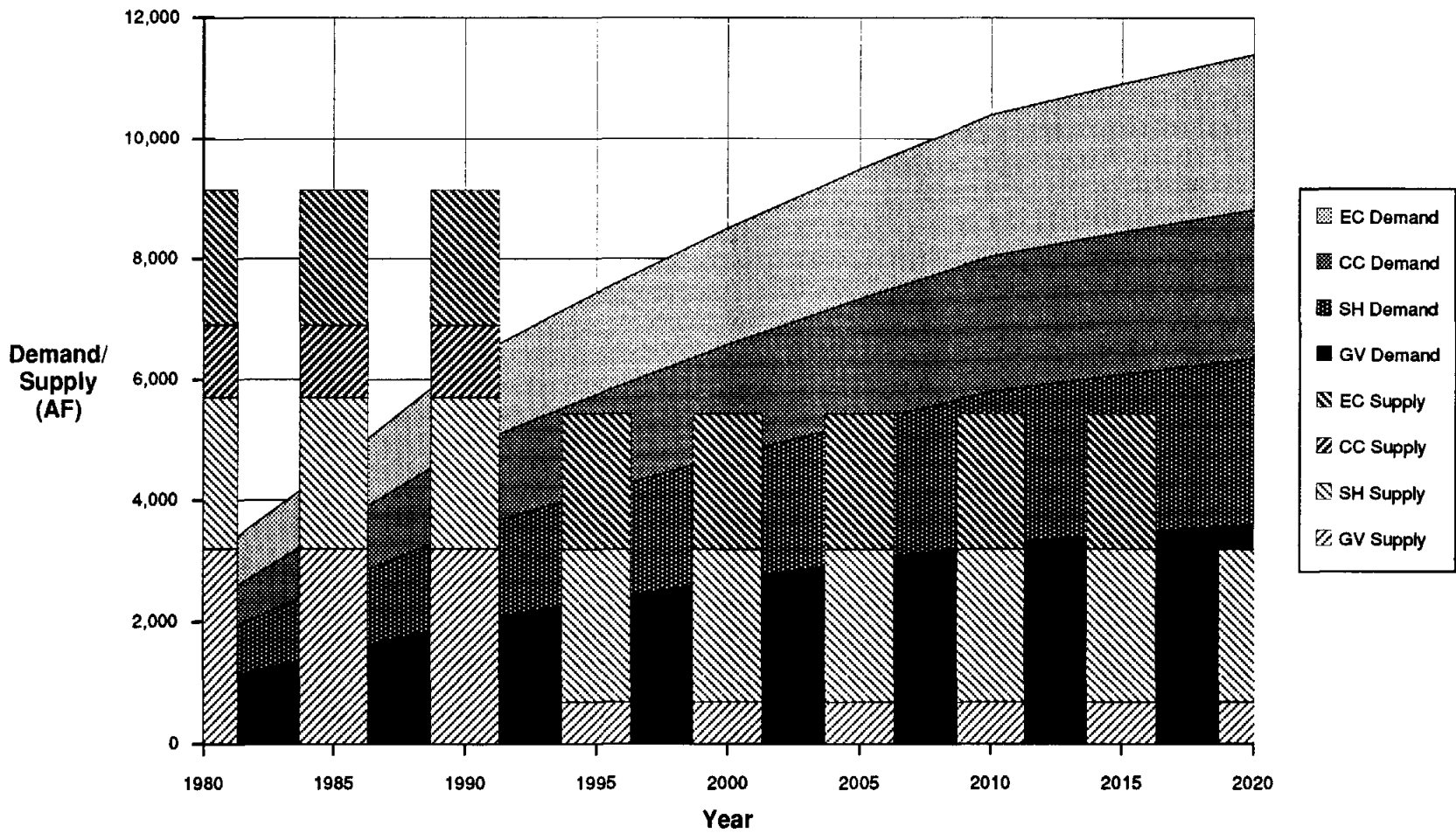
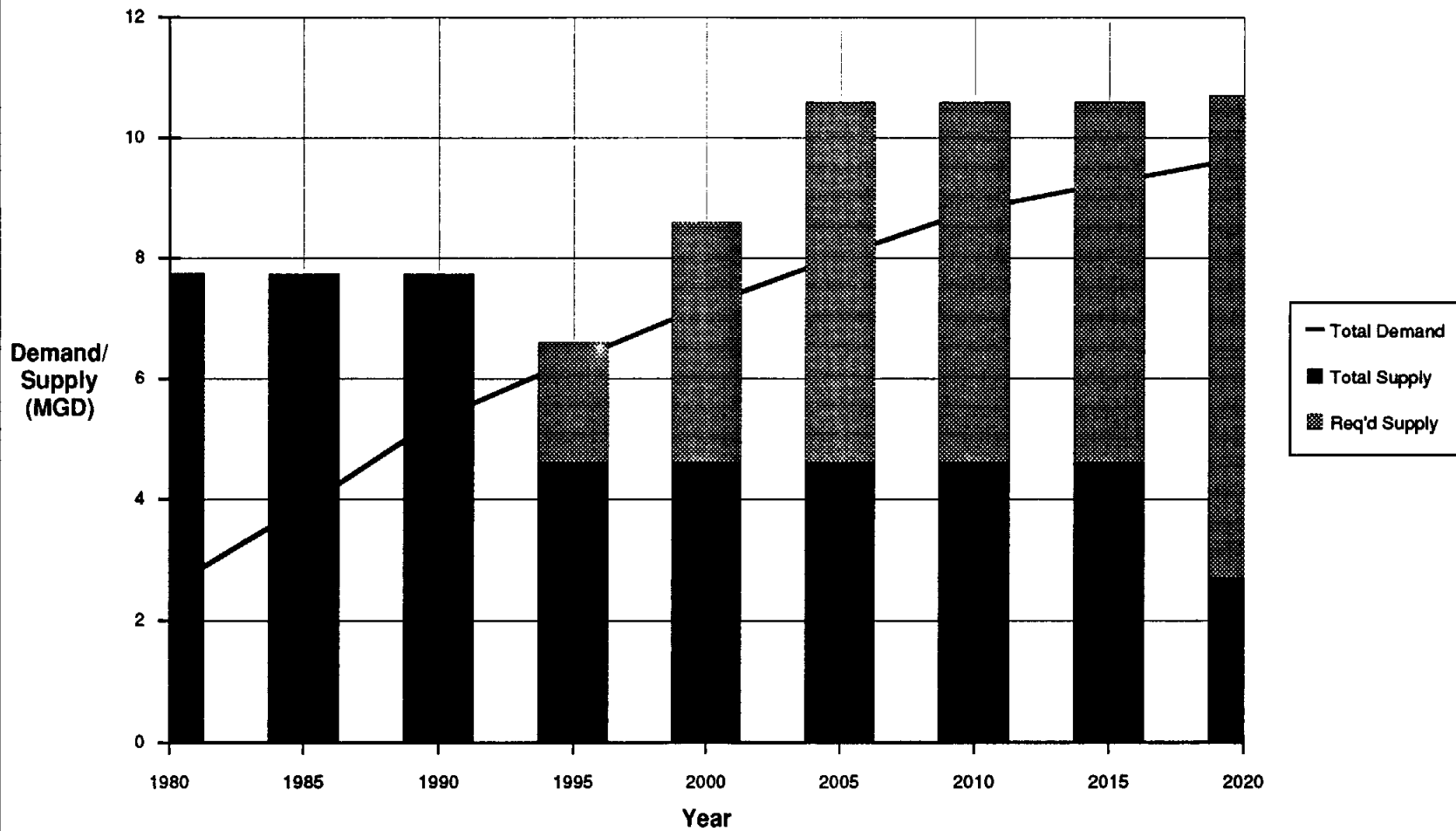

Figure 6-22  
Worst Case Projected CRWA Member Future Water  
Demand and Required Supplemental Supplies



**Figure 6-23  
Drought Case Projected CRWA Member Future Water  
Demand and Supplies**

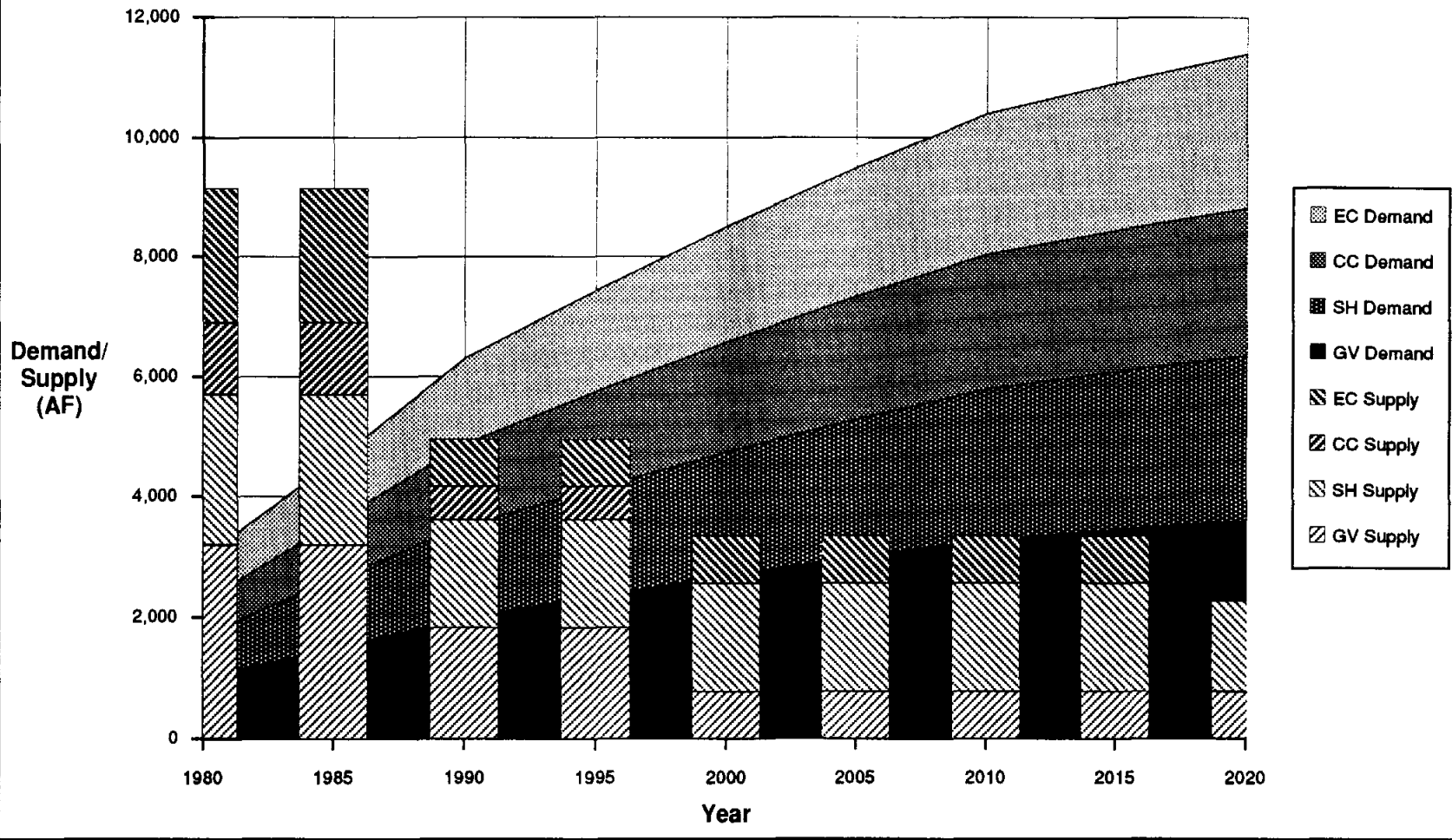

Figure 6-24  
Drought Case Projected CRWA Member Future Water  
Demand and Required Supplemental Supplies

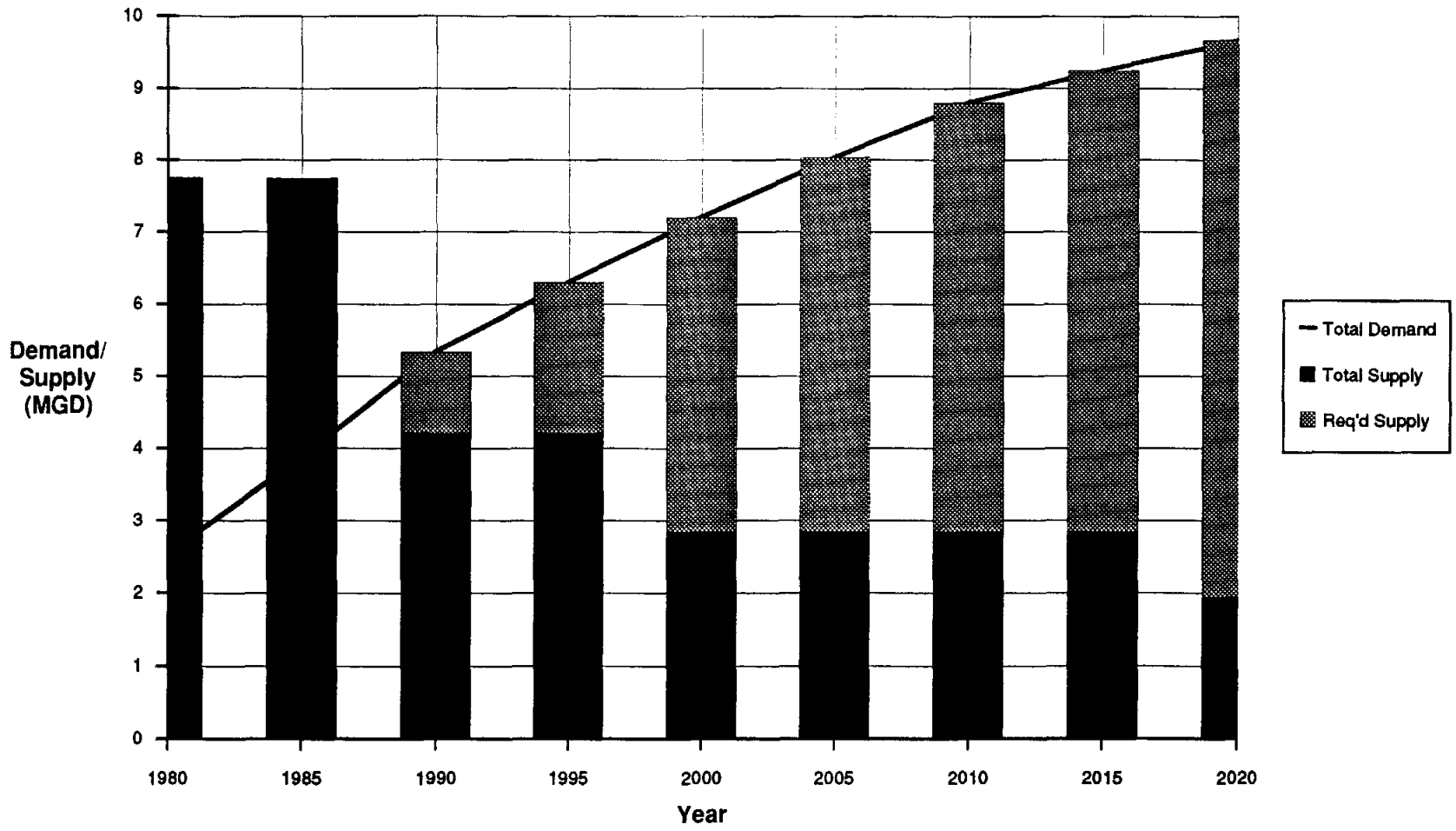
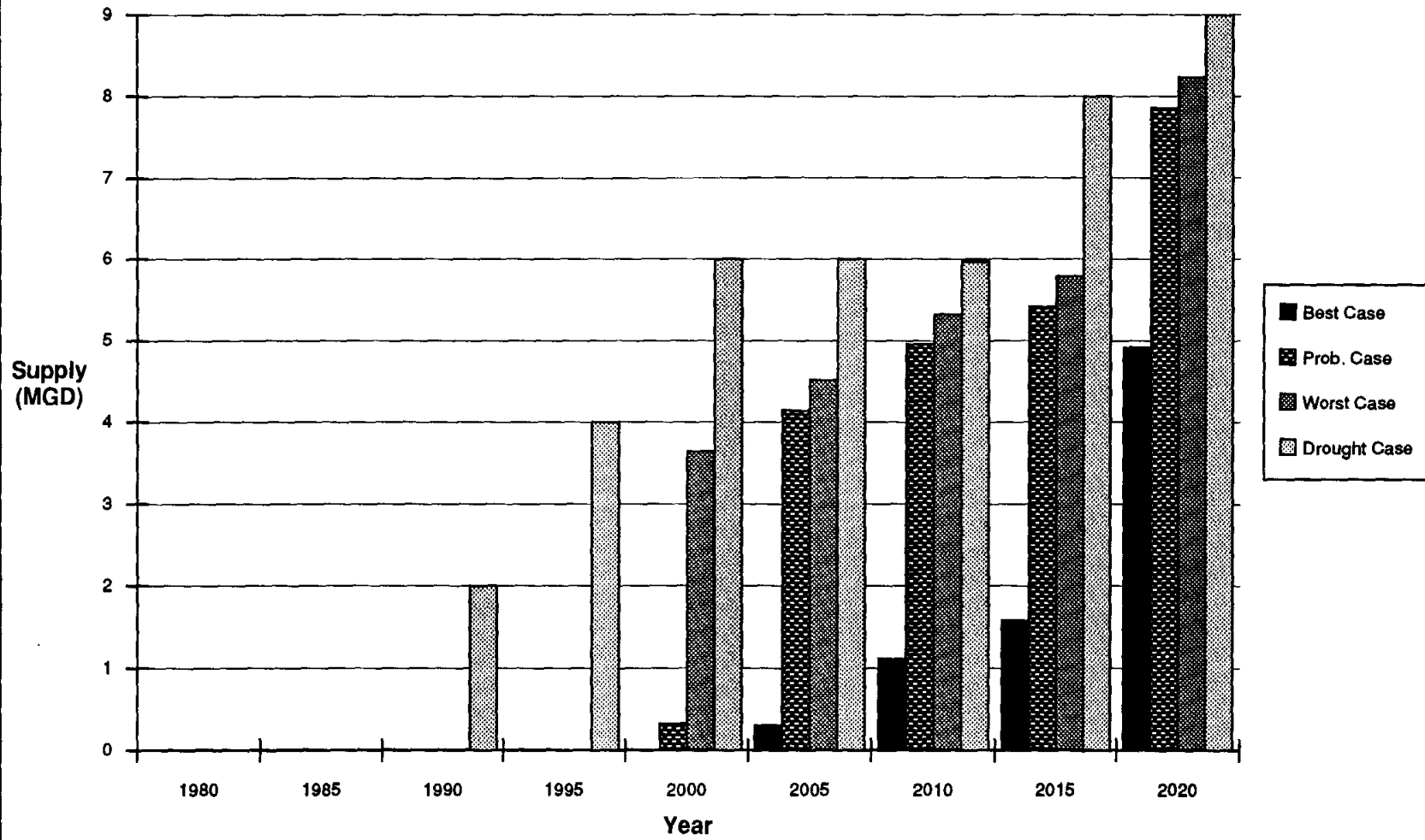

Figure 6-25  
 Projected CRWA Member Future Required Supplemental Supplies



### 6.5.2 Purchase Water From Others

#### Guadalupe-Blanco River Authority

Purchasing water from the GBRA can be accomplished under three (3) possible development scenarios. The first is the CRWA purchase water from GBRA under a take or pay contract, build their own treatment plant and directly supply CRWA members. A second alternative is to let the GBRA build and operate the water treatment plant and supply service to the CRWA member WSCs as customers. And, a third alternative is to purchase water from GBRA and utilize the excess capacity in the City of Seguin's water treatment plant. From an engineering standpoint, construction of a new treatment plant by CRWA or GBRA would require equal effort and are, thus, both neutral. The size, location and type of facility constructed will probably be the same under both scenarios. The water supply to CRWA customers would be a firm supply guaranteed under a purchase or supply contract. Both systems would be relatively flexible in that the treatment plants could be easily interconnected to all four CRWA member WSCs. The environmental impacts created by this option would also be minimal in that there would be no impact to wetlands, no creation or destruction of aquatic habitat and no net reduction in river flows.

Purchasing water from the GBRA under a take-or-pay contract and treating that water in the City of Seguin water treatment plant appears to be a superior short-term option, from an engineering standpoint. This option would delay to some future date construction of a CRWA or GBRA water treatment plant. In the short-term the supply would still be relatively firm as it would be a purchased contractual amount. In the long-term however, the supply firmness may be somewhat diminished and limited by the available excess capacity of the Seguin treatment plant. At some point the CRWA members would be forced to seek an alternative treatment plant of their own. That point appears to be around 2005. This option is also very flexible in that the central location of the Seguin treatment plant lends itself to minimization of distribution system lines.

From an environmental standpoint this is also a very good option in that there would be essentially no disturbance of terrestrial or aquatic habitats or net reductions in downstream Guadalupe River flows.

#### New Braunfels/San Marcos

Purchasing raw water or from NBU or the City of San Marcos is a neutral option with respect to engineering. Either option would require construction of a water treatment plant by CRWA. In the short-term, supplies could be relatively firm; however, in the long-term it is doubtful that either New Braunfels Utilities or the City of San Marcos will have sufficient supplies to satisfy the growing demand of the CRWA members. This option is relatively flexible in that it would allow interconnects between CRWA members and would allow CRWA to locate the treatment facility at the desired location.

### Edwards Underground Water District

Purchasing water from the EUWD would involve construction of new wells in the existing GVWSC and CCWSC fields. In the short-term, the supply would be adequate to satisfy CRWA demands; however, in the long-term, with the increasing demand on the Edwards Aquifer, it is unlikely that this option will be sufficient to supply the total long-term demands of the CRWA members. This option also would have short and long-term environmental impacts in that it would be adding stress to an already stressed aquifer system.

### Irrigation Water Rights

Purchasing irrigation permits and converting them to municipal permits has few engineering obstacles. The availability of water would still, however, be subject to TWC approval and would be subordinate to all senior and superior downstream water. Being that there is only 1,300 AF of available irrigation supply within or nearby the CRWA service area, it is unlikely that the supply would be sufficient to totally satisfy additional demand in either the short or long-term. In addition this would be a relatively inflexible option, in that in the conversion from irrigation rights to municipal rights, it is possible that the municipal permit holder will be tied to the same monthly demand distribution as were in effect under the conditions of the agricultural permit, i.e., all of the water may be allocated during summer months.

#### 6.5.3. Wells

### Local Shallow Wells

Developing shallow wells as a significant supply of water for CRWA members would be a difficult operation. Being near surface water bearing sands which are often quickly drained and contain very little in the way of substantive volumes of available water, would take a large number of wells to develop even a modest supply. Therefore, the engineering feasibility of this option is low, as is the firmness of supply. Shallow formations are recharged only as a result of direct rainfall or stream underflow and run-off, during times of drought these supplies would be depleted quickly and additional water sources would still be needed to supply CRWA demands. Incorporation of a large number of wells into a comprehensive management operation program would be a cumbersome system to manage. Therefore, a shallow well system must be considered inflexible. Pumping shallow wells will deplete soil moisture in all or in areas surrounding the well pump fields. This could artificially drain some important surface wetlands and result in changing local vegetation types.



### Leona Formation

Obtaining water from the Leona gravels would also involve a relatively large number of wells. The strata is very thin. Well drawdowns, as discussed in the Southwestern Engineering Inc., Report to the City of Seguin, are rapid and well fields can experience short-term depletions. In addition the majority of recharge to the Leona sands comes from underflow and bankflow of the Guadalupe River; therefore in times of drought it is likely the sands would not be recharged at a sufficient rate to yield a firm supply to CRWA.

### Carrizo-Wilcox Formation

The Carrizo-Wilcox formation is a deep formation and wells of sufficient capacity to supply CRWA would have to be drilled to at least 1,200 feet. In addition, it will take approximately 15 miles of transmission line to get the water from the well field to a central point in the distribution system. However, these are not unusual or insurmountable engineering obstacles; only expensive. The Carrizo-Wilcox formation will yield a firm supply for CRWA users throughout the planning period. This well field would be compatible with other sources; however there may be some minerals problems with the water that would require construction of a water treatment facility.

#### 6.5.4 Conjunctive Use or Subordination of GBRA Hydropower Rights

Conjunctive use or subordination of hydropower rights offers probably the most interesting of the long-term solutions to CRWA's water supply problems. From an engineering feasibility standpoint, the option would be easy to implement, the scenario would be to use GBRA dams H-4 and H-5 as a water supply system. Releases from H-4 to H-5 as part of the system operation would generate electricity as would excess flow diversion from reservoir H-5 or dedicated releases for downstream demands from H-5 generate electricity. This constant source of power could then in turn be used to off-set the costs or supply the power for transfer water from down near Gonzales to CRWA service area. This option would still require construction of surface water treatment plant. In the short-term, conjunctive use of GBRA hydropower lakes would yield a firm supply. In the long-term, hydropower dams H-4 and H-5, operated as a system, may yield a firm supply. However, determination of the firm yield of that system is beyond the scope of this study. This option would be flexible in that water pumped from near Gonzales could be entered into the CRWA system at any location. There would be no short or long-term environmental impacts to this option, in that there would be no creation or destruction of aquatic or terrestrial habitat.

#### 6.5.5 Appropriation of Surface Water Without Impoundment

##### Guadalupe River Within Service Area

There appears to be little chance of appropriation of local Guadalupe River flows without impoundment for consumption by CRWA members. Unappropriated flow data sets generated by the TWC (Table 6-5) indicate that the stretch of the river between Canyon reservoir and the City of Gonzales has essentially no firm supplies of unappropriated water.

##### Guadalupe River Other

Appropriation of surface water without impoundment below GBRA hydrodam H-5 is a feasible option; however, the firmness of such supplies are questionable. Examination of the unappropriated flow data set and flow frequency distributions of the Guadalupe River (Table 6-5 and Figure 6-16) show that during drought periods there may be insufficient water to supply CRWA members.

##### San Marcos River

Appropriation of surface water without impoundment from the San Marcos River also suffers from apparent supply problems (Table 6-6). In the short-term when demand is low, the San Marcos River water could serve as viable adjunct to Edwards Aquifer water and other surface water sources. However, in the long-term it is doubtful that there is sufficient supply available to carry the CRWA through any significant drought.

#### 6.5.6 Appropriation Surface Water With Impoundment

##### Guadalupe River Within Service Area

Even with impoundment, there does not appear to be sufficient appropriated water in the Guadalupe River to serve CRWA needs. Construction of an off-channel impoundment or on-channel reservoir of sufficient volume to accommodate CRWA members would be very expensive because of the large volume that would be required to produce a firm yield from what are, at best, sporadic divertable flows in the Guadalupe River. Therefore, this does not appear to be a viable short-term option and a poor long-term option. It is doubtful that a firm supply could be generated at all in the stretch of the Guadalupe River between Canyon Reservoir and GBRA hydropower dam H-5.

##### Guadalupe River Other

There appears to be sufficient water below GBRA hydropower dam H-5 when appropriated in conjunction with off-channel storage to supply CRWA needs. However, the supply would require construction of not

only a surface water treatment plant and off-channel storage but pumping facilities of sufficient size to deliver the water to the CRWA service area.

### San Marcos

The San Marcos River development option suffers from many of the same problems as appropriation of Guadalupe River water within the CRWA service area option. Significant off-channel storage capacity would be necessary to construct to carry CRWA demands through a critical drought. In addition, location of the off-channel storage would be located at the extreme edge of the CCWSC service area, which would require pumpage of long distances to serve the other CRWA members. Thus, this option is not flexible.

Portions of the San Marcos River between San Marcos and Luling are used extensively by sport fishermen, kayakers, and other recreators. Possible destruction of aquatic habitat or dimension of San Marcos River flows is likely to be very unpopular.

#### 6.5.7 Transfer of Coastal Basin Demands

Transfer of Coastal Basin Demands to Lake Texana is fraught with a number of engineering problems. In the short-term, the option may be infeasible in that Formosa Plastics has not yet started construction on its expanded facilities at Point Comfort: thus, it may take some time before the transmission lines from Lake Texana to Point Comfort become available. In addition, it will be a significant engineering undertaking to construct transmission lines from Point Comfort across Lavaca Bay to Port Lavaca and from the east side of Port Lavaca to the City's water treatment facility on the west side of town. The supply, however, would be relatively firm and long-term environmental impacts will be minimal.

#### 6.5.8 Improve Coastal Canal System

Improving the efficiency of the coastal basin canal system would pose a high level of engineering difficulty. Canals are large; and providing some form of lining would require construction of a new parallel system. In addition, supplies derived from the source would be infirm and subject to seasonal demand distributions of the original permits.

**6.6 Supply Options Recommended for Detailed Evaluation**

The relative advantages and disadvantages of each of the possible supply options are summarized in Table 6-7.

Based on the total scores of the various options in the evaluation Matrix (Table 6-8), the following supply options (Table 6-9 - in descending order of score) are selected for further detailed evaluation.

**Supply Options  
 (Table 6-9)**

<b>Short-term Options</b>	<b>Long-term Options</b>
Limited/No Action	Purchase Water from GBRA with CRWA treatment
Purchase water from GBRA with Seguin treatment	Purchase water from GBRA with GBRA treatment
Purchase water from GBRA GBRA with CRWA treatment	Wells to the Carrizo-Wilcox Formation
Wells to the Carrizo-Wilcox Formation	Conjunctive Use/Subordination of GBRA Hydropower Rights
	Appropriation with Impoundment below GBRA Hydrodam H 5

**Table 6-7  
Supply Option Advantages and Disadvantages**

OPTION	ADVANTAGES	DISADVANTAGES
<p>1. Limited/No Action</p> <p>a. No Action</p>     <p>b. Limited Action</p>	<ul style="list-style-type: none"> <li>• Least expensive alternative for both short and long term, no long term costs.</li> <li>• Flexibility is unaffected for both the short and long term.</li> <li>• No environmental impact for both short or long term.</li>   <li>• Shallow aquifer depth.</li> <li>• Minimal cost for well construction.</li> <li>• Short term supply will be relatively firm, under existing permits and contracts.</li> <li>• Relative low cost for short and long term.</li> </ul>	<ul style="list-style-type: none"> <li>• Uncertain future permit status.</li> <li>• Subject to EUD Drought Management.</li> <li>• Supplies may be inadequate during drought conditions.</li>   <li>• Short term response will increase stress on Edwards Aquifer by increases, withdrawal rate and increasing recharge time.</li> <li>• Long-term response multiplies short term impact.</li> </ul>
<p>2. Purchase from Others</p> <p>a. GBRA (1) CRWA Treatment Plant</p>	<ul style="list-style-type: none"> <li>• Firm supply in short and long term since quantity is contracted.</li> <li>• In the long term, cost will be inexpensive due to price of Canyon water is currently \$45 (however there may not be the ability to lock in the price for the duration of the contract).</li> <li>• Very flexible option to optimize the system for both short and long term. Construction can be phase as demand increases.</li> <li>• No environmental impact for both short or long terms.</li> </ul>	<ul style="list-style-type: none"> <li>• Requires surface water treatment plant.</li> <li>• Short term the cost will be expensive because of GBRA contract is take-or-pay and costs associated with purchase and building in advance of demand.</li> <li>• In the long term, cost will be inexpensive due to price of Canyon water is currently \$45 a/f (however there may not be the ability to lock in the price for the duration of the contract).</li> <li>• Contract cost escalator clause may increase price of water when new reservoirs are developed in GBRA</li> </ul>

OPTION	ADVANTAGES	DISADVANTAGES
(2) GBRA Treatment Plant	<ul style="list-style-type: none"> <li>• Costs associated with construction and operation of a new water treatment plant born by GBRA.</li> <li>• Short and long-term supply very firm. Guaranteed supply contract.</li> <li>• Supply grows as a function of demand.</li> <li>• No environmental impact for both short or long terms.</li> </ul>	<ul style="list-style-type: none"> <li>• Unknown initial water cost.</li> <li>• Variable cost of water through time.</li> <li>• User ends up paying capital and O &amp; M costs anyway.</li> <li>• Source not controlled by CRWA.</li> </ul>
(3) Seguin Treatment Plant  b. NBU/San Marcos	<ul style="list-style-type: none"> <li>• Short-term - limited construction required.</li> <li>• Short-term - purchased water supply very firm.</li> <li>• Short-term - least cost new source alternative.</li> <li>• Long-term initial construction will be for larger CRWA plant deriving economies of scale through delayed expenditures.</li> <li>• Very flexible option to optimize the system for both short and long-term. Construction can be phased as demand increases.</li> <li>• No environmental impact.</li> <li>• Short-term - purchased water supply very firm.</li> <li>• Short-term more flexible contract terms than available from GBRA.</li> <li>• Very flexible option to optimize the system for both short and long term. Construction can be phase as demand increases.</li> <li>• No environmental impact for both short or long terms.</li> </ul>	<ul style="list-style-type: none"> <li>• Must secure long-term source.</li> <li>• Long-term - still have to build CRWA treatment plant.</li> <li>• Variable water costs.</li> <li>• Two contracts required:            GBRA Supply Contract            Seguin Treatment Contract</li> <li>• GBRA Supply Contract likely to be take-or-pay.</li> <li>• Short-term option only.</li> <li>• Short and long-term, a treatment plant will have to be built.</li> <li>• Long-term- supply may not be available.</li> <li>• Long-term - still need to secure water from GBRA.</li> </ul>

OPTION	ADVANTAGES	DISADVANTAGES
<p>c. Edwards District</p> <p>d. Irrigation Permits</p>	<ul style="list-style-type: none"> <li>• No surface plant required.</li> <li>• Short-term - firm supply purchased from EUD.</li> <li>• Neutral flexibility as wells will be in the same location only added capacity.</li> <li>• No environmental impact for both short or long-terms</li> <li>• Enviromental short and long term same amount of water same as irrigation conditions.</li> </ul>	<ul style="list-style-type: none"> <li>• Viable only as short-term option.</li> <li>• Subject to Edwards Drought Management Plan.</li> <li>• Still need to develop other sources.</li> <li>• May add stress to aquifer.</li> <li>• Politically unpopular with San Antonio.</li> <li>• Short and long-term will require treatment plant capacity.</li> <li>• Viable short-term option only.</li> <li>• Only 1300 AF/yr available.</li> <li>• Long-term supply totally insufficient supply.</li> <li>• Need to upgrade permit status at TWC from category 3 to category 1.</li> <li>• Demand distribution may be same as agricultural permit demand distribution variations may be incompatible with actual demands.</li> <li>• Surface treatment required</li> <li>• All rights newer than 1914 subordinate to GBRA hydropower rights.</li> <li>• Negotiated purchase of each right.</li> </ul>
<p>3. Wells</p> <p>a. Shallow Wells</p>	<ul style="list-style-type: none"> <li>• Short and long term easy to construct, no special engineering required, design is simple.</li> </ul>	<ul style="list-style-type: none"> <li>• Viable short-term option only.</li> <li>• Rapid well depletion.</li> <li>• Supply drought sensitive.</li> </ul>

<b>OPTION</b>	<b>ADVANTAGE</b>	<b>DISADVANTAGE</b>
a. Shallow Wells (cont.)		<ul style="list-style-type: none"><li>• Limited quantities.</li><li>• Inflexible - system operation difficult.</li><li>• Potential significant environmental impacts.</li><li>• Requires high well to supply ratio.</li><li>• Short and long-term availability defined by location of wells.</li><li>• Potential long-term soil moisture depletion and wetlands reduction.</li></ul>
b. Leona Formation		<ul style="list-style-type: none"><li>• Will require treatment - high costs and technical difficulties, nitrate removal.</li><li>• Short and long-term limited recharge area and capability; inexpensive to mine due to shallow hard water; nitrate high over entire area; could not be relied for heavy use.</li><li>• Supply limited.</li><li>• Soil moisture depletion.</li></ul>
c. Carrizo-Wilcox Formation	<ul style="list-style-type: none"><li>• Extensive formation; good recharge capability; large supply but deep; firm supply.</li><li>• Compatible with existing systems.</li><li>• No depletion of surface water.</li><li>• No negative environmental impacts.</li></ul>	<ul style="list-style-type: none"><li>• Relatively hard water - may need softening.</li><li>• Relatively long pumping distances to service area.</li><li>• May need large well field.</li></ul>





OPTION	ADVANTAGE	DISADVANTAGE
<p>6. Appropriate S.W. w/ Impoundment</p> <p>a. Guadalupe - Local</p> <p>b. Guadalupe- Below GBRA H-5</p> <p>c. San Marcos</p>	<ul style="list-style-type: none"> <li>• Relatively firm supply.</li> <li>• Requires least storage of appropriation options.</li> <li>• Appropriated water is free.</li> <li>• CRWA would hold appropriation rights.</li> <li>• Creation of aquatic habitat.</li>   <li>• Relatively firm supply.</li> <li>• Appropriated water is free</li> <li>• CRWA would hold appropriation.</li> <li>• Supportable with higher customer basis.</li> <li>• Creation of impoundment of aquatic habitat.</li>   <li>• Appropriated water is free.</li> <li>• CRWA would hold appropriation.</li> <li>• Creation of impoundment of aquatic habitat.</li> </ul>	<ul style="list-style-type: none"> <li>• Expensive.</li> <li>• Requires lengthy TWC appropriation process.</li> <li>• Limited to long-term option.</li>   <li>• Too expensive for short-term option.</li> <li>• Subject to lengthy TWC appropriation process.</li> <li>• Limited to long-term option.</li>   <li>• Relatively non-firm supply.</li> <li>• Would require large storage.</li> <li>• Very expensive.</li> <li>• Short and long-term not as flexible as CRWA, less firm supply than purchases from Canyon reservoir</li> <li>• Limited to long-term option.</li> </ul>
<p>7. Trans. of Coastal Basin Demands</p>	<ul style="list-style-type: none"> <li>• Improve efficiency of GBRA system.</li> <li>• Relatively firm supply.</li> <li>• Reduced channel losses between Canyon Reservoir and Victoria.</li> </ul>	<ul style="list-style-type: none"> <li>• Requires concurrence of GBRA.</li> <li>• Requires TWC permit review and authorization.</li> <li>• May be expensive to implement.</li> </ul>

OPTION	ADVANTAGE	DISADVANTAGE
8. Improve Coastal Canal System Efficiency	<ul style="list-style-type: none"> <li>• Reduced channel losses between Guadalupe River and users.</li> </ul>	<ul style="list-style-type: none"> <li>• Must build parallel channel.</li> <li>• Converted irrigation rights will have same distribution factors.</li> <li>• Must have TWC concurrence.</li> <li>• <u>Very</u> expensive.</li> <li>• Seasonal availability.</li> </ul>
9. Recharge Local Groundwater Form.		<ul style="list-style-type: none"> <li>• Only reliable formation is Carrizo sand.</li> <li>• Need to control total surface.</li> <li>• Requires deep wells.</li> <li>• Fairly long pumping distance to CRWA service area.</li> </ul>
10. Wastwater Reuse		<ul style="list-style-type: none"> <li>• Unsewered service area.</li> <li>• No firm supply available.</li> <li>• Sewer system as well as water system too expensive.</li> <li>• Very inflexible.</li> </ul>

**Table 6-8  
CRWA Water Supply Options Evaluation Matrix**

Source Option	Engineering a/										
	Engineering Feasibility		Firm Supply		Flexibility		Environmental		Total Engineering		
	Short-term	Long-term	Short-term	Long-term	Short-term	Long-term	Short-term	Long-term	Short-term	Long-term	
1 Limited/No Action											
a. No Action	10	10	5	-10	0	0	0	-2	15	-2	
b. Limited Action	5	5	5	-5	0	0	-1	-2	9	-2	
2 Purchase from OTHERS									0	0	
a. GBRA									0	0	
(1) CRWA Treatment Plant	0	0	10	10	2	2	0	0	12	12	
(2) GBRA Treatment Plant	5	0	10	10	2	2	0	0	17	12	
(3) Seguin Treatment Plant	5	0	10	5	2	2	0	0	17	7	
b. NBU/San Marcos	0	0	10	0	2	2	0	0	12	2	
c. Edwards District	5	5	5	-5	0	0	-1	-2	9	-2	
d. Irrigation Permits	0	0	-5	-10	-2	-2	0	0	-7	-12	
3 Wells									0	0	
a. Shallow Wells	5	5	-10	-10	-2	-2	-2	-2	-9	-9	
b. Leona Formation	-5	-5	0	-10	0	-2	0	0	-5	-17	
c. Carrizo-Wilcox Formation	-3	-3	10	10	0	0	2	2	9	9	
4 Conjunctive Use/Subordination of GBRA Hydropower Rights	2	2	10	10	2	2	2	2	16	16	
5 Appropriate S.W. w/o Impoundment									0	0	
a. Guadalupe - Local	-5	-5	-10	-10	-2	-2	0	0	-17	-17	
b. Guadalupe - Below GBRA H-5	-2	-2	5	5	2	2	0	0	5	5	
c. San Marcos	0	0	0	-5	0	0	-2	-2	-2	-7	
6 Appropriate S.W. w/ Impoundment									0	0	
a. Guadalupe - Local	-8	-5	10	10	2	2	2	2	6	9	
b. Guadalupe - Below GBRA H-5	-8	-5	10	10	2	2	2	2	6	9	
c. San Marcos	-8	-5	10	10	2	2	2	2	6	9	
7 Trans. of Coastal Basin Demands	-5	-5	8	8	2	2	2	2	7	7	
8 Improve Coast Canal Sys. Efficiency	-10	-10	0	-5	-2	-2	2	2	-10	-15	
9 Recharge Local Groundwater Form.									0	0	
a. Guadalupe Source									0	0	
b. Edwards Source									0	0	
10 Wastewater Reuse	-10	-10	-8	-8	-2	-2	2	2	-18	-18	

Supply Evaluation Weighting	Issues	Range	
Engineering Feasibility	Are there significant engineering challenges to this option?	-10	10
Firm Supply	Will this option carry CRWA through drought conditions? With/without augmentation?	-10	10
Flexibility	How well does this option fit in with implementation of other options?	-2	2
Environmental	Habitat Preservation/Creation and other possible environmental impacts.	-2	2

**Table 6-8 (Continued)**  
**CRWA Water Supply Options Evaluation Matrix**

Source Option	Institutional/Legal b/										
	Legal Considerations		Institutional Considerations		Public Acceptance		Total Institutional		TOTAL		
	Short-term	Long-term	Short-term	Long-term	Short-term	Long-term	Short-term	Long-term	Short-term	Long-term	
1. Limited/No Action											
a. No Action	0	-6	0	-6	4	-2	4	-14	19	-16	
b. Limited Action	0	-6	-4	-6	4	-2	0	-14	9	-16	
2. Purchase from OTHERS											
a. GBRA											
(1) CRWA Treatment Plant	0	0	-2	2	0	2	-2	4	10	16	
(2) GBRA Treatment Plant	0	0	-4	-4	-2	2	-6	-2	11	10	
(3) Seguin Treatment Plant	0	0	-6	-6	2	2	-4	-4	13	3	
b. NBU/San Marcos	0	0	-4	-4	0	-2	-4	-6	8	-4	
c. Edwards District	0	0	0	0	-2	-2	-2	-2	7	-4	
d. Irrigation Permits	0	0	0	0	0	-2	0	-2	-7	-14	
3. Wells											
a. Shallow Wells	-4	-4	0	0	0	0	-4	-4	-13	-13	
b. Leona Formation	0	0	0	0	0	0	0	0	-5	-17	
c. Carrizo-Wilcox Formation	0	0	0	0	0	0	0	0	9	9	
4. Conjunctive Use/Subordination of GBRA Hydropower Rights	0	0	-6	-6	0	0	-6	-6	10	10	
5. Appropriate S.W. w/o Impoundment											
a. Guadalupe - Local	0	0	0	0	0	0	0	0	-17	-17	
b. Guadalupe - Below GBRA H-5	0	0	0	0	0	0	0	0	5	5	
c. San Marcos	0	0	0	0	0	0	0	0	-2	-7	
6. Appropriate S.W. w/ Impoundment											
a. Guadalupe - Local	0	0	0	0	0	0	0	0	6	9	
b. Guadalupe - Below GBRA H-5	0	0	0	0	0	0	0	0	6	9	
c. San Marcos	0	0	-2	-2	-4	-4	-6	-6	0	3	
7. Trans. of Coastal Basin Demands	0	0	-6	-6	-6	-6	-12	-12	-5	-5	
8. Improve Coast Canal Sys. Efficiency	0	0	-6	-6	-6	-6	-12	-12	-22	-27	
9. Recharge Local Groundwater Form.											
a. Guadalupe Source	0	0	-3	-3	0	0	-3	-3	-3	-3	
b. Edwards Source	0	0	-3	-3	0	0	-3	-3	-3	-3	
10. Wastewater Reuse	0	0	6	6	4	4	10	10	-8	-8	

b/ Supply Evaluation Weighting	Issues	Range	
Legal Restrictions	Are there any legal obstacles, impediments or restrictions to implementation of this option?	-8	8
Institutional Considerations	What institutional arrangements can/must be made to facilitate/allow development of this option?	-6	6
Public Acceptance	Will the CRWA members accept this option? Will other regional and state entities accept this option?	-6	6

## 7.0 DETAILED COST EVALUATION

### 7.1 General

Twenty-three possible future CRWA supply options were formulated for review. Preliminary matrix evaluations reduced the number of options selected for further detailed economic evaluation to ten; five short-term and five long-term options. Those ten options are:

#### 7.1.1 Short-Term Options

- Limited/No Action Alternative - Continue pumping from the Edwards Aquifer to the maximum extent allowed under the conditions of existing permits. Exercise all existing contractual supply arrangements with the City of San Antonio and NBU for the duration of current and option time frames and apply to the EUWD for additional permits sufficient to supply the total projected CRWA growth.
- Purchase water from GBRA with treatment by CRWA - Purchase water from GBRA through a take-or-pay contract and construct CRWA owned and operated treatment facilities near Dittmar Falls at Lake Dunlap.
- Purchase treated water from GBRA - Purchase wholesale treated water from a GBRA owned and operated facility, located near Dittmar Falls at Lake Dunlap.
- Purchase water from GBRA with treatment by the City of Seguin - Purchase water from GBRA on a take-or-pay contract and use an existing 2 MGD of excess capacity in the City of Seguin treatment facility until such time as the City needs the capacity. Build additional needed CRWA capacity at Dittmar Falls.
- Develop well fields in the Carrizo-Wilcox Formation - Drill a number of wells into the Carrizo-Wilcox Formation south of Seguin. As the formation water is known to contain elevated levels of iron, surface treatment will be required. This plant would be constructed by CRWA near Dittmar Falls.

#### 7.1.2 Long-Term Options

- Purchase water from GBRA with treatment by CRWA - Purchase water from GBRA through a take-or-pay contract and construct CRWA owned and operated treatment facilities near Dittmar Falls at Lake Dunlap.
- Purchase treated water from GBRA - Purchase wholesale treated water from a GBRA owned and operated facility, located near Dittmar Falls at Lake Dunlap.

CANYON REGIONAL WATER SUPPLY STUDY  
DETAILED COST EVALUATION

- Purchase water from GBRA with treatment by the City of Seguin - Purchase water from GBRA on a take-or-pay contract and use an existing 2 MGD of excess capacity in the City of Seguin treatment facility until such time as the City needs the capacity. Build additional needed CRWA capacity at Dittmar Falls.
- Develop well fields in the Carrizo-Wilcox Formation - Drill a number of wells into the Carrizo-Wilcox Formation south of Seguin. As the formation water is known to contain elevated levels of iron, surface treatment will be required. This plant would be constructed by CRWA near Dittmar Falls.
- Appropriate surface water downstream of GBRA hydropower dam H-5 - Appropriate unappropriated surface water downstream of GBRA hydropower dam H-5; construct diversion and treatment facilities and pump back to the CRWA service area.

With the exception of the short-term Limited/No Action Alternative and the long-term Appropriation of surface water below GBRA hydropower dam H-5, the most feasible short- and long-term option lists are the same.

The Limited/No Action short-term option ranked highest in the matrix evaluation and it has not been dismissed from further consideration as it clearly offers the least-cost future supply alternative. However, at this time, the duration and supply quantity viability of a Limited/No Action Alternative is unknown; making a detailed cost evaluation impossible. Therefore, the detailed cost evaluations will include all long-term options.

All supply, treatment and distribution system evaluations are predicated on the Drought Condition Probable Edwards Aquifer Supply Scenario. [EUWD will renew all existing transport permits for one (1) additional ten year period. After ten years all transport permits will be terminated. And, under Phase III of the EUWD Drought Management Plan, all users will be limited to 70% of actual 1984 pumpage.] Tables 7-1 through 7-5 and Figures 7-1 through 7-3 summarize the projected Probable Drought Condition demands for CRWA and each respective WSC.

## 7.2 Phased Improvements

Each of the potential supply and development options was evaluated in five year increments beginning in 1990. Improvements which must be implemented immediately to correct immediate drought condition deficiencies are shown to occur in 1990. Each five year increment subsequent to 1990 reflects improvements which must be in place at that time to correct projected supply and/or treatment capacity deficiencies. Transmission main improvements are shown to occur twice (short-term and long-term improvements). The initial short-term transmission main improvements are recommended for

Table 7-1  
Probable Case Drought Condition Supply Option Projection  
Green Valley Water Supply Corporation

Year	Demand (AF/yr)	Demand (GPM)	Permitted Withdrawal EUWD (GPM) a/ b/ c/	Grandfathered Withdrawal From EUWD (GPM) d/	Interconnect With NBU (GPM) e/	Supply Deficit/Surplus (GPM)	Supply Deficit/Surplus (MGD)	Supply Deficit/Surplus (AF/yr)
1990	1,995	1,237	583	480	72	-102	-0.15	-164
1995	2,355	1,460	583	480	72	-325	-0.48	-535
2000	2,692	1,669	0	480	0	-1,189	-1.71	-1,918
2005	3,001	1,860	0	480	0	-1,380	-1.99	-2,227
2010	3,289	2,039	0	480	0	-1,559	-2.24	-2,515
2015	3,453	2,141	0	480	0	-1,661	-2.39	-2,679
2020	3,608	2,237	0	480	0	-1,757	-2.53	-2,834

- a/ Assumes drought management plan in effect. Drought management plan restricts allowable withdrawals from EUWD to 70% of 1984 pumpage.  
b/ Total 1984 pumpage from EUWD was 1,343.3 AF. Allowable drought condition pumpage is 940 AF/yr (583 GPM).  
c/ Assumes existing permit with EUWD expires in 1995 and is not renewed.  
d/ Assume grandfathered water from Edwards District (685 GPM) is supplied in perpetuity but is reduced by 30 percent due to drought management restrictions.  
e/ Assumes that under the EUWD Drought Management Plan, the amount of water available for purchase will be equal to 70% of the amount purchased in 1984. Green Valley WSC purchased 166.3 AF (103 GPM) of water from NBU in 1984. Seventy percent of that value is 72 GPM.

Table 7-2  
Probable Case Drought Condition Supply Option Projection  
Springs Hill Water Supply Corporation

Year	Demand (AF/yr)	Demand (GPM)	Permitted Diversion Rate From GBRA (GPM) a/	Interconnect With NBU (GPM) b/ c/	Supply Deficit/Surplus (GPM)	Supply Deficit/Surplus (MGD)	Supply Deficit/Surplus (AF/yr)
1990	1,519	942	930	178	166	0.24	268
1995	1,792	1,111	930	178	-3	0.00	-5
2000	2,049	1,270	930	178	-162	-0.23	-262
2005	2,285	1,417	930	178	-309	-0.44	-498
2010	2,503	1,552	930	178	-444	-0.64	-716
2015	2,629	1,630	930	178	-522	-0.75	-842
2020	2,747	1,703	930	0	-773	-1.11	-1,247

- a/ Assumes firm diversion rate of 1,500 AF/yr (1.34 MGD) is available through 2020.  
b/ Assumes that existing interconnect with New Braunfels is extended through 2019 but expires prior to beginning of 2020.  
c/ Assumes that under the EUWD Drought Management Plan, the amount of water available for purchase will be equal to 70% of the amount purchased in 1984. Springs Hill WSC purchased 411.9 AF (255 GPM) of water from NBU in 1984. Seventy percent of that value is 178 GPM.

Table 7-3  
Probable Case Drought Condition Supply Option Projection  
Crystal Clear Water Supply Corporation

Year	Demand (AF/yr)	Demand (GPM)	Permitted Withdrawal From EUWD (GPM) a/ b/ c/	Supply Deficit/Surplus (GPM)	Supply Deficit/Surplus (MGD)	Supply Deficit/Surplus (AF/yr)
1990	1,363	845	343	-502	-0.72	-810
1995	1,609	997	343	-654	-0.94	-1,056
2000	1,839	1,140	0	-1,140	-1.64	-1,839
2005	2,051	1,271	0	-1,271	-1.83	-2,051
2010	2,247	1,393	0	-1,393	-2.01	-2,247
2015	2,360	1,463	0	-1,463	-2.11	-2,360
2020	2,465	1,528	0	-1,528	-2.20	-2,465

- a/ Assumes drought management plan in effect. Drought management plan restricts allowable withdrawals from EUWD to 70% of 1984 pumpage.  
b/ Total 1984 pumpage from EUWD was 790.1 AF. Allowable drought condition pumpage is 553.07 AF/yr (343 GPM).  
c/ Assumes existing permit with EUWD expires in 1995 and is not renewed.

Table 7-4  
Probable Case Drought Condition Supply Option Projection  
East Central Water Supply Corporation

Year	Demand (AF/yr)	Demand (GPM)	Interconnect With SACWB (GPM) a/ b/	Supply Deficit/Surplus (GPM)	Supply Deficit/Surplus (MGD)	Supply Deficit/Surplus (AF/yr)
1990	1,430	886	491	-395	-0.57	-638
1995	1,687	1,046	491	-555	-0.80	-895
2000	1,929	1,196	491	-705	-1.01	-1,137
2005	2,150	1,333	491	-842	-1.21	-1,358
2010	2,356	1,461	491	-970	-1.40	-1,564
2015	2,474	1,534	491	-1,043	-1.50	-1,682
2020	2,585	1,602	0	-1,602	-2.31	-2,585

- a/ Assumes that East Central will continue receiving water from SACWB through 2017.  
b/ Assumes that under the EUWD Drought Management Plan, the amount of water available for purchase will be equal to 70% of the amount purchased in 1984. East Central WSC purchased 1,003.5 AF (622 GPM) of water from SACWB in 1984. Seventy percent of that value is 491 GPM.



**Table 7-5**  
**Probable Case Drought Condition Supply Option Projection**  
**Canyon Regional Water Authority**

Year	System Supply Deficit/Surplus					Cumulative Treatment Requirement (MGD)
	Green Valley WSC (MGD) a/	Springs Hill WSC (MGD) b/	Crystal Clear WSC (MGD) c/	East Central WSC (MGD) d/	CRWA Total (MGD)	
1990	-0.15	0.24	-0.72	-0.57	-1.20	2.00
1995	-0.48	0.00	-0.94	-0.80	-2.22	4.00
2000	-1.71	-0.23	-1.64	-1.01	-4.60	6.00
2005	-1.99	-0.44	-1.83	-1.21	-5.47	6.00
2010	-2.24	-0.64	-2.01	-1.40	-6.28	8.00
2015	-2.39	-0.75	-2.11	-1.50	-6.75	8.00
2020	-2.53	-1.11	-2.20	-2.31	-8.15	8.00

a/ From Figure 7-1.

b/ From Figure 7-2.

c/ From Figure 7-3.

d/ From Figure 7-4.



Figure 7-2  
Drought Case Projected CRWA Member Future Water  
Demand and Required Supplemental Supplies

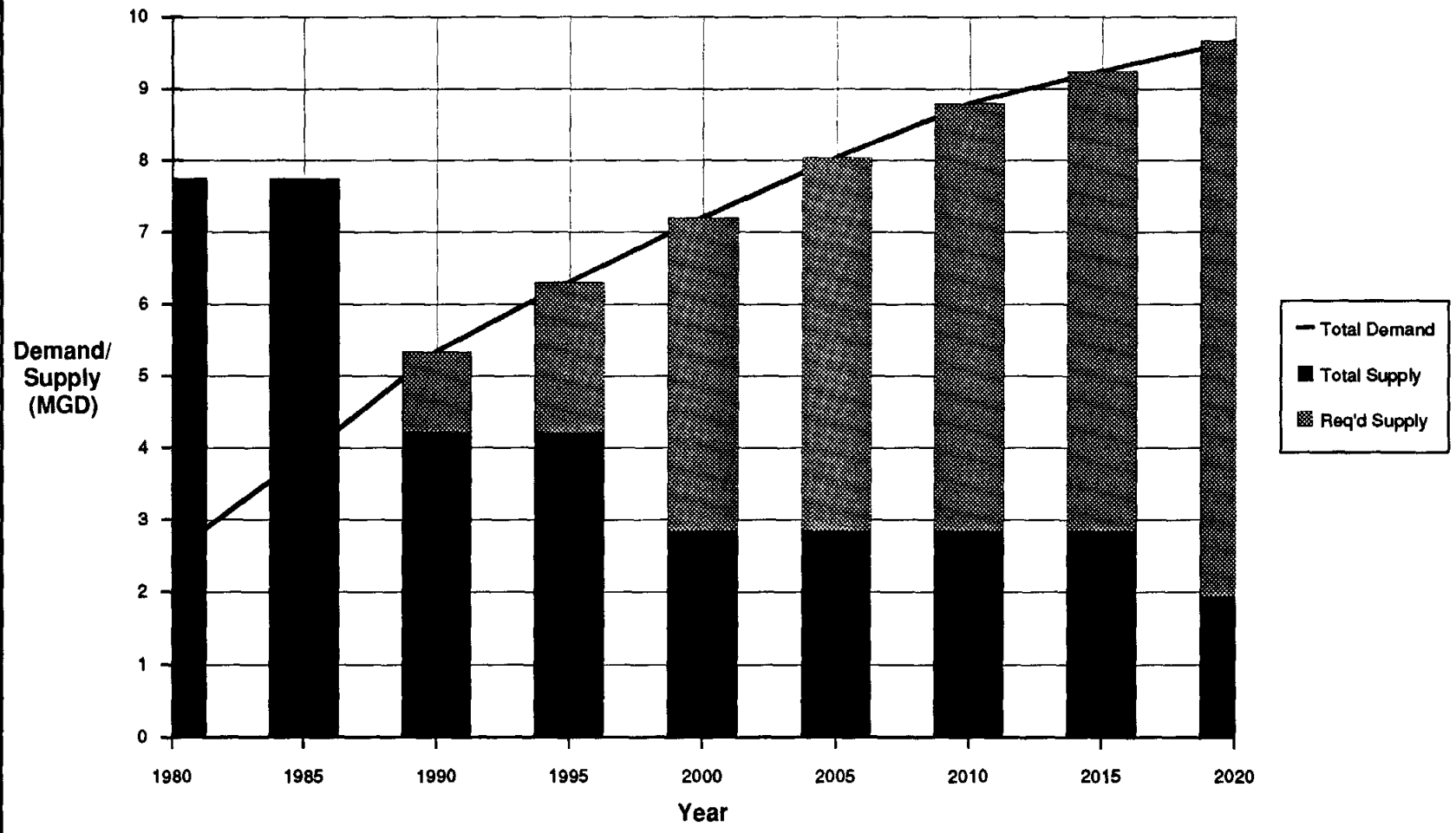
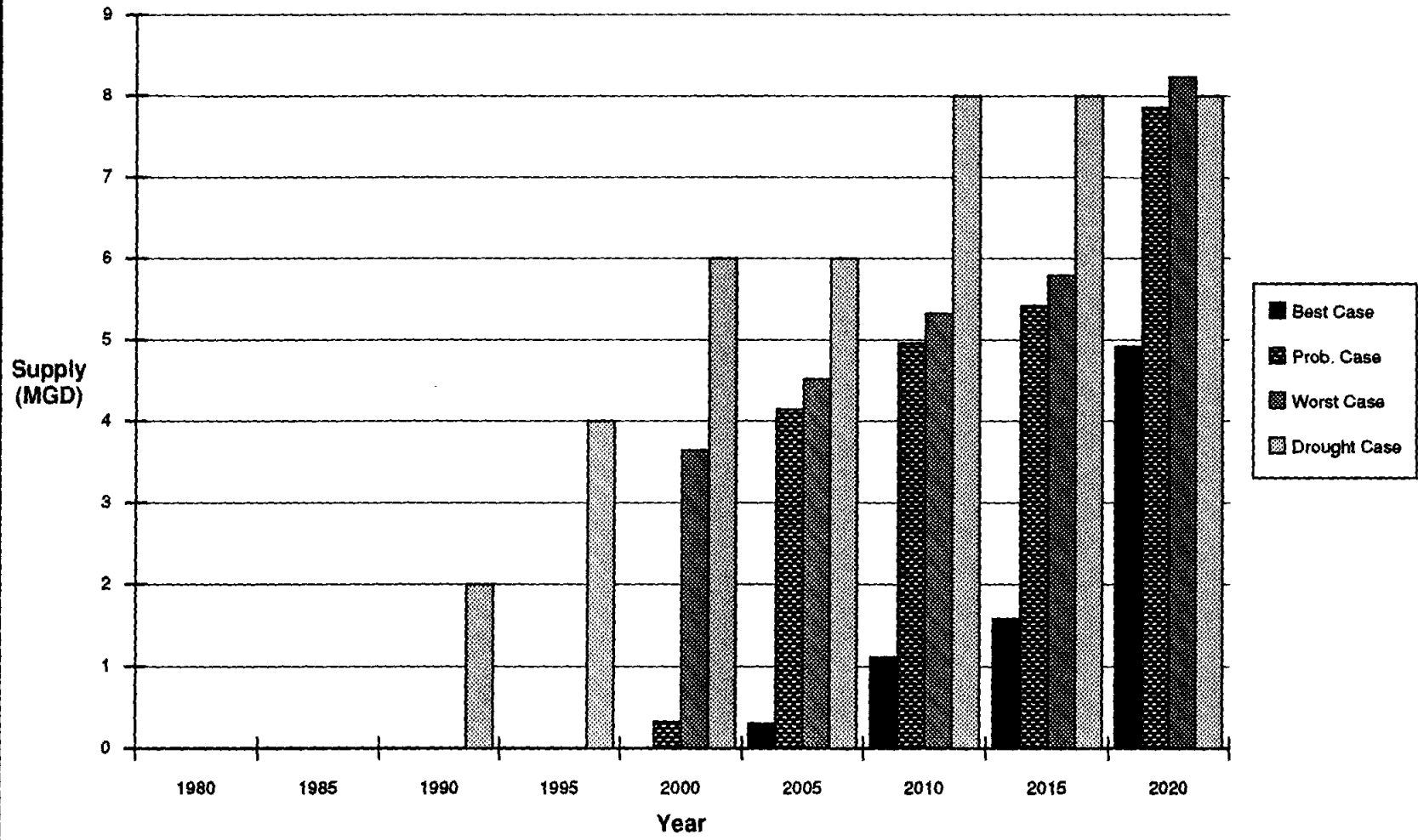

Figure 7-3  
Projected CRWA Member Future Required Supplemental Supplies



**CANYON REGIONAL WATER SUPPLY STUDY  
DETAILED COST EVALUATION**

implementation in 1990 and reflect lines sized to meet supply requirements through 2005. A second set of long-term line improvements are scheduled for in 2005 and reflect lines sized to meet additional system demands through 2020. Supply, storage, pumping (number and capacity of pumps) and phasing requirements are assumed to be identical for each short- and long-term distribution system development option.

### **7.3 Construction Costs**

The major cost components evaluated for each potential supply and development option were:

- Raw water supply,
- Treatment,
- Storage,
- Pumping and
- Transmission (limited to pipe sizes  $\geq$  4 in-diameter).

Supply, treatment, storage and pumping requirements were determined based on Texas Department of Health (TDH) design criteria for public water systems of more than 250 connections or over 750 population. The following is a summary of the TDH criteria.

#### **Groundwater Supply**

- Total storage capacity - 200 gallons per connection with a maximum of 5.0 MG required.
- Pressure maintenance facilities - For systems serving more than 2,500 connections, elevated storage based on 100 gallons per connection with a maximum of 5.0 MG required.
- Well capacity - Two or more wells having a total rated capacity of 0.6 gpm per connection.
- Service pumps - Two or more pumps having a total rated capacity of 2.0 gpm per connection or total capacity of 1,000 gpm and able to meet peak demands, whichever is less.

#### **Surface Water Supply**

- Total storage capacity - 200 gallons per connection with a maximum of 5.0 MG required.
- Covered clear well storage or ground storage at the plant of 25% of the total storage capacity, with a maximum requirement of 1 MG, will be required to provide adequate chlorine contact time.
- Pressure maintenance facilities - For systems serving more than 2,500 connections, elevated storage based on 100 gallons per connection with a maximum of 5.0 MG required.

CANYON REGIONAL WATER SUPPLY STUDY  
DETAILED COST EVALUATION

- Raw water pumps and transfer pumps - duplicate pumps with each having a rated capacity of 0.6 gpm per connection.
- Treatment plant capacity - 0.6 gpm per connection under normal rated design capacity.
- Service pumps - Two or more having a total rated capacity of 2.0 gpm per connection or total capacity of 1,000 gpm and able to meet peak demands, whichever is less.

Transmission main sizes were determined based on a maximum normal design velocity of 5 fps, or less, and an allowable pipe friction loss of 200 ft. A Hazen-Williams roughness coefficient ('C') of 120 was used for each line size determination.

Other components included in the distribution system evaluation were: cost of engineering related services; cost of land acquisition; cost for surveying and staking; legal and administrative costs; costs associated with permits and fees; and, contingencies. A summary of annualized costs for each distribution system development option is presented later in this section.

#### 7.4 Supply/Treatment

In order to determine overall supply requirements, each WSC was evaluated for availability of supply versus demand. From these, an overall CRWA demand was determined. Deficits for the CRWA range from 1.20 MGD in 1990 to 8.15 MGD in 2020 (Table 7-5), assuming no improvements are made to existing facilities. Green Valley, Crystal Clear, and East Central WSCs each display projected drought condition supply deficits beginning in 1990. With the exception of the first five-year planning period (1990 to 1995), projected deficits for Green Valley WSC and Crystal Clear WSC increase relatively uniformly for the duration of the study period. A dramatic increase in the projected supply deficit for Green Valley and Crystal Clear occurs in 1995 due to the loss or severe restriction of water supplied from the Edwards Underground District. A similar dramatic increase in supply deficit is projected for East Central WSC by 2020 due to the expiration of its supply agreement with the San Antonio City Water Board. Springs Hill WSC appears to have sufficient supplies until the period between 1995 and 2000; however, there may be some difficulty in servicing the northern portion of the service area due to distribution system limitations. Treatment capacity improvements are recommended to be made in 2 MGD increments to allow for cost effective phasing of construction. In order to meet projected demands, system treatment capacity upgrades of 2 MGD each will be required in 1990, 1995, 2000, and 2010.

Other components included in the supply and treatment evaluation were: cost of engineering related services; cost of land acquisition; cost for surveying and staking; legal and administrative costs; costs associated with permits and fees; and, contingencies. A summary of annualized costs for each supply and treatment development option is presented later in this section.

## 7.5 Storage

Total storage and elevated storage requirements have been evaluated for each WSC and the CRWA. Tables 7-6 through 7-11 provide a summary of these requirements. Based on TDH criteria, none of the member WSCs is currently deficient in total storage. However, deficiencies in elevated storage capacity do exist. Each of the WSCs use hydropneumatic tanks to maintain system pressure. With the exception of East Central WSC, each of the WSCs operates elevated reservoirs to assist in the maintenance of system pressure. Due to the number of connections which each of the WSCs serve (greater than 2,500), hydropneumatic tanks cannot be counted as a pressure maintenance source. Elevated storage in the amount of 100 gallons per connection is required by the TDH for systems which serve greater than 2,500 connections. Based on the number of connections projected for 1990, East Central WSC is deficient in elevated storage in the amount of 286,900 gallons in 1990.

## 7.6 Pumping

Infrastructure pumping requirements were determined using TDH design criteria. Based on projected supply requirements, Springs Hill and East Central WSCs are currently deficient in pumping capacity in the amounts of 1,500 gpm and 2,918 gpm, respectively. Crystal Clear WSC is projected to be deficient in the amount of 1,170 gpm by 2000 with Green Valley WSC projected to be deficient in the amount of 248 gpm by 2005. Tables 7-12 through 7-16 summarize projected pumping requirements through 2020. Table 7-17 summarizes phased improvements to the pumping system.

## 7.7 Transmission Mains

Transmission main systems were developed for each of the five supply scenarios being evaluated. Due to the large area served by the CRWA, line length and size contribute substantially to the anticipated cost of the alternatives being evaluated. Therefore, four-inch diameter lines were the smallest lines included in the transmission system evaluation. Lines smaller than four-inches are assumed to be part of the WSC distribution system and excluded from this cost evaluation. In order to minimize the cost of installing lines to serve individual service areas, certain lines were oversized to accommodate flows for combinations of service areas. Thus, if a line were needed to transport water from Point A to Point B and that line passed through Service Areas C, D, and E, only one line would be installed. The first portion of the line would be sized to serve areas C, D, and E. Upon exiting Area C, the line size would be reduced to that needed to serve areas D and E. Upon exiting Area D, the line is sized only to serve Area E. Individual portions of the overall transmission main system were sized based on estimated demands in the areas the lines serve. Demands were estimated based on existing plant locations.

Plant locations were evaluated to determine what percentage of total system storage and pumping they provided for each WSC. Demand percentages were assigned to each plant location. Projected demands

Table 7-6  
Summary of Total and Elevated Storage Requirements  
Green Valley Water Supply Corporation

Year	Projected Connections	Total Storage Required (Gallons)	Total Elev. Storage Required (Gallons)	Total Storage Existing (Gallons)	Total Elev. Storage Existing (Gallons)	Total Storage Deficit/Surplus (Gallons)	Elevated Storage Deficit/Surplus (Gallons)
1990	3,727	745,400	372,700	2,198,000	600,000	1,825,300	227,300
1995	4,515	903,000	451,500	2,198,000	600,000	1,746,500	148,500
2000	5,302	1,060,400	530,200	2,198,000	600,000	1,667,800	69,800
2005	6,074	1,214,800	607,400	2,198,000	600,000	1,590,600	-7,400
2010	6,846	1,369,200	684,600	2,198,000	600,000	1,513,400	-84,600
2015	7,289	1,457,800	728,900	2,198,000	600,000	1,469,100	-128,900
2020	7,732	1,546,400	773,200	2,198,000	600,000	1,424,800	-173,200

Table 7-7  
Summary of Total and Elevated Storage Requirements  
Springs Hill Water Supply Corporation

Year	Projected Connections	Total Storage Required (Gallons)	Total Elev. Storage Required (Gallons)	Total Storage Existing (Gallons)	Total Elev. Storage Existing (Gallons)	Total Storage Deficit/Surplus (Gallons)	Elevated Storage Deficit/Surplus (Gallons)
1990	3,205	641,000	320,500	1,870,000	602,000	1,549,500	281,500
1995	3,882	776,400	388,200	1,870,000	602,000	1,481,800	213,800
2000	4,559	911,800	455,900	1,870,000	602,000	1,414,100	146,100
2005	5,223	1,044,600	522,300	1,870,000	602,000	1,347,700	79,700
2010	5,887	1,177,400	588,700	1,870,000	602,000	1,281,300	13,300
2015	6,268	1,253,600	626,800	1,870,000	602,000	1,243,200	-24,800
2020	6,649	1,329,800	664,900	1,870,000	602,000	1,205,100	-62,900

Table 7-8  
Summary of Total and Elevated Storage Requirements  
Crystal Clear Water Supply Corporation

Year	Projected Connections	Total Storage Required (Gallons)	Total Elev. Storage Required (Gallons)	Total Storage Existing (Gallons)	Total Elev. Storage Existing (Gallons)	Total Storage Deficit/Surplus (Gallons)	Elevated Storage Deficit/Surplus (Gallons)
1990	3,086	617,200	308,600	3,265,800	504,000	2,957,200	195,400
1995	3,738	747,600	373,800	3,265,800	504,000	2,892,000	130,200
2000	4,390	878,000	439,000	3,265,800	504,000	2,826,800	65,000
2005	5,030	1,006,000	503,000	3,265,800	504,000	2,762,800	1,000
2010	5,669	1,133,800	566,900	3,265,800	504,000	2,698,900	-62,900
2015	6,036	1,207,200	603,600	3,265,800	504,000	2,662,200	-99,600
2020	6,403	1,280,600	640,300	3,265,800	504,000	2,625,500	-136,300

Table 7-9  
Summary of Total and Elevated Storage Requirements  
East Central Water Supply Corporation

Year	Projected Connections	Total Storage Required (Gallons)	Total Elev. Storage Required (Gallons)	Total Storage Existing (Gallons)	Total Elev. Storage Existing (Gallons)	Total Storage Deficit/Surplus (Gallons)	Elevated Storage Deficit/Surplus (Gallons)
1990	2,869	573,800	286,900	561,000	0	274,100	-286,900
1995	3,475	695,000	347,500	561,000	0	213,500	-347,500
2000	4,081	816,200	408,100	561,000	0	152,900	-408,100
2005	4,676	935,200	467,600	561,000	0	93,400	-467,600
2010	5,270	1,054,000	527,000	561,000	0	34,000	-527,000
2015	5,611	1,122,200	561,100	561,000	0	-100	-561,100
2020	5,952	1,190,400	595,200	561,000	0	-34,200	-595,200



**Table 7-10**  
**Summary of Total and Elevated Storage Requirements**  
**Canyon Regional Water Authority**

Year	Projected Connections	Total Storage Required (Gallons)	Total Elev. Storage Required (Gallons)	Total Storage Existing (Gallons)	Total Elev. Storage Existing (Gallons)	Total Storage Deficit/Surplus (Gallons)	Elevated Storage Deficit/Surplus (Gallons)
1990	12,887	2,577,400	1,288,700	7,894,800	1,706,000	6,606,100	417,300
1995	15,610	3,122,000	1,561,000	7,894,800	1,706,000	6,333,800	145,000
2000	18,332	3,666,400	1,833,200	7,894,800	1,706,000	6,061,600	-127,200
2005	21,003	4,200,600	2,100,300	7,894,800	1,706,000	5,794,500	-394,300
2010	23,672	4,734,400	2,367,200	7,894,800	1,706,000	5,527,600	-661,200
2015	25,204	5,000,000	2,520,400	7,894,800	1,706,000	5,374,400	-814,400
2020	26,736	5,000,000	2,673,600	7,894,800	1,706,000	5,221,200	-967,600

**Table 7-11**  
**Elevated Storage Cost and Scheduling**  
**Canyon Regional Water Authority**

Year	Suggested Elevated Storage (Gallons)	Estimated Unit Cost (\$/Gal)	Estimated Elev. Storage Cost (\$)
1990a/	500,000	0.90	\$450,000
1995	0	0.00	\$0
2000	0	0.00	\$0
2005b/	100,000	1.00	\$100,000
2010c/	250,000	0.90	\$225,000
2015d/	175,000	0.95	\$166,250
2020	0	0.00	\$0

- a/ 500,000 gallon tank for East Central WSC
- b/ 100,000 gallon tank for Green Valley WSC
- c/ 100,000 gallon tank for East Central WSC  
150,000 gallon tank for Crystal Clear WSC
- d/ 75,000 gallon tank for Springs Hill WSC  
100,000 gallon tank for Green Valley WSC

**Table 7-12  
Pumping Requirements/Deficit/Surplus  
Green Valley Water Supply Corporation**

Year	Projected Connections	Required Pumping (GPM)	Available Pumping (GPM)	Pumping Deficit/Surplus (GPM)
1990	3,727	7,454	11,900	4,446
1995	4,515	9,030	11,900	2,870
2000	5,302	10,604	11,900	1,296
2005	6,074	12,148	11,900	-248
2010	6,846	13,692	11,900	-1,792
2015	7,289	14,578	11,900	-2,678
2020	7,732	15,464	11,900	-3,564

**Table 7-13  
Pumping Requirements/Deficit/Surplus  
Springs Hill Water Supply Corporation**

Year	Projected Connections	Required Pumping (GPM)	Available Pumping (GPM)	Pumping Deficit/Surplus (GPM)
1990	3,205	6,410	4,910	-1,500
1995	3,882	7,764	4,910	-2,854
2000	4,559	9,118	4,910	-4,208
2005	5,223	10,446	4,910	-5,536
2010	5,887	11,774	4,910	-6,864
2015	6,268	12,536	4,910	-7,626
2020	6,649	13,298	4,910	-8,388

**Table 7-14  
Pumping Requirements/Deficit/Surplus  
Crystal Clear Water Supply Corporation**

Year	Projected Connections	Required Pumping (GPM)	Available Pumping (GPM)	Pumping Deficit/Surplus (GPM)
1990	3,086	6,172	7,610	1,438
1995	3,738	7,476	7,610	134
2000	4,390	8,780	7,610	-1,170
2005	5,030	10,060	7,610	-2,450
2010	5,669	11,338	7,610	-3,728
2015	6,036	12,072	7,610	-4,462
2020	6,403	12,806	7,610	-5,196

**Table 7-15  
Pumping Requirements/Deficit/Surplus  
East Central Water Supply Corporation**

Year	Projected Connections	Required Pumping (GPM)	Available Pumping (GPM)	Pumping Deficit/Surplus (GPM)
1990	2,869	5,738	2,820	-2,918
1995	3,475	6,950	2,820	-4,130
2000	4,081	8,162	2,820	-5,342
2005	4,676	9,352	2,820	-6,532
2010	5,270	10,540	2,820	-7,720
2015	5,611	11,222	2,820	-8,402
2020	5,952	11,904	2,820	-9,084

Table 7-16  
Pumping Requirements/Deficit/Surplus  
Canyon Regional Water Authority

Year	Projected Connections	Required Pumping (GPM)	Available Pumping (GPM)	Pumping Deficit/Surplus (GPM)
1990	12,887	25,774	27,240	1,466
1995	15,610	31,220	27,240	-3,980
2000	18,332	36,664	27,240	-9,424
2005	21,003	42,006	27,240	-14,766
2010	23,672	47,344	27,240	-20,104
2015	25,204	50,408	27,240	-23,168
2020	26,736	53,472	27,240	-26,232

Table 7-17  
Cumulative Pumping Requirements and Estimated Costs  
Canyon Regional Water Authority

Year	Projected Connections	Required Pumping (GPM)	Available Pumping (GPM) <sup>a/</sup>	Pumping Deficit/Surplus (GPM)	Number of Supplemental Pumps Required	Estimated Cost of Supplemental Pumps
1990	12,887	25,774	27,240	1,466	0	\$0
1995	15,610	31,220	27,240	-3,980	9	\$54,000
2000	18,332	36,664	31,220	-5,444	12	\$72,000
2005	21,003	42,006	36,664	-5,342	12	\$72,000
2010	23,672	47,344	42,006	-5,338	12	\$72,000
2015	25,204	50,408	47,344	-3,064	7	\$42,000
2020	26,736	53,472	50,408	-3,064	7	\$42,000

a/ Assumes previous deficit is added to current available total.

b/ Based on using 450 gpm pumps rated at 50 HP and 200 ft TDH. Cost per pump, installed, is assumed to be \$6,000.

for the years 2005 and 2020 were used to pro-rate demands through each WSC. Line sizes were calculated based on flow combinations through each line segment. Schematics for each supply option are presented which show the demand percentages and the line designations. Summaries of demands and line sizes accompany each schematic. An explanation of the location and size of the transmission mains options is presented below.

## 7.8 Cost Evaluation Summary

The following sections are a sequential listing of CRWA water supply options based on the matrix evaluation of Section 6. Cost Option 1 is considered the most cost effective; Option 5 the least cost effective.

### 7.8.1 Option 1 - Purchase Water from GBRA with Treatment by CRWA

Option 1 assumes that the CRWA constructs a surface water treatment facility below Dittmar Falls and purchases water from GBRA for treatment. Figure 7-4 illustrates the path which water is supplied to the various WSCs. Water is supplied to the system in two directions. Crystal Clear WSC is serviced by a transmission main which extends across the Guadalupe River and then along Hwy 758 to Hwy 123 (line L8). From the intersection of Hwy 758 and Hwy 123, water is distributed throughout the remainder of the Crystal Clear system. Water is supplied to the remaining three WSCs through a transmission main which extends west from Dittmar Falls to Hwy 725 (line L39). From here, flow is directed north along Union Wine Rd. to the northern reaches of the Green Valley system (line L40). Service to the remainder of Green Valley and the remaining WSCs is provided through line L38. Line L33 is sized to service only Springs Hill WSC. Line L43 is sized to service on East Central WSC. Lines L1, L2, L18, L46, and L47 are not used in this option. Table 7-18 summarizes flows, pipe sizes, and estimated costs for individual sections of the transmission main system for the initial phase of line installation. Estimated transmission main construction costs for Phase I is \$3,539,000. Estimated transmission main construction costs for Phase II is \$2,042,500. Table 7-19 summarizes the second phase of line installation.

Total costs for Option 1 phased installation of treatment and distribution facilities, taken forward at an annual inflation rate of 4% per year to the actual date of expenditure, are shown in Tables 7-20 and 7-21. Total annualized costs for all phases of Option 1 installation, including the cost of water under three possible take-or-pay options (2,250 AF/yr, 4,500 AF/yr, and 9,000 AF/yr) are shown in Tables 7-22 through 7-24. Total CRWA cost per 1,000 gal, total annual costs and total cumulative costs (all assuming no rate-leveling financing mechanisms in place) for Option 1 are shown in Figures 7-5 through 7-7.

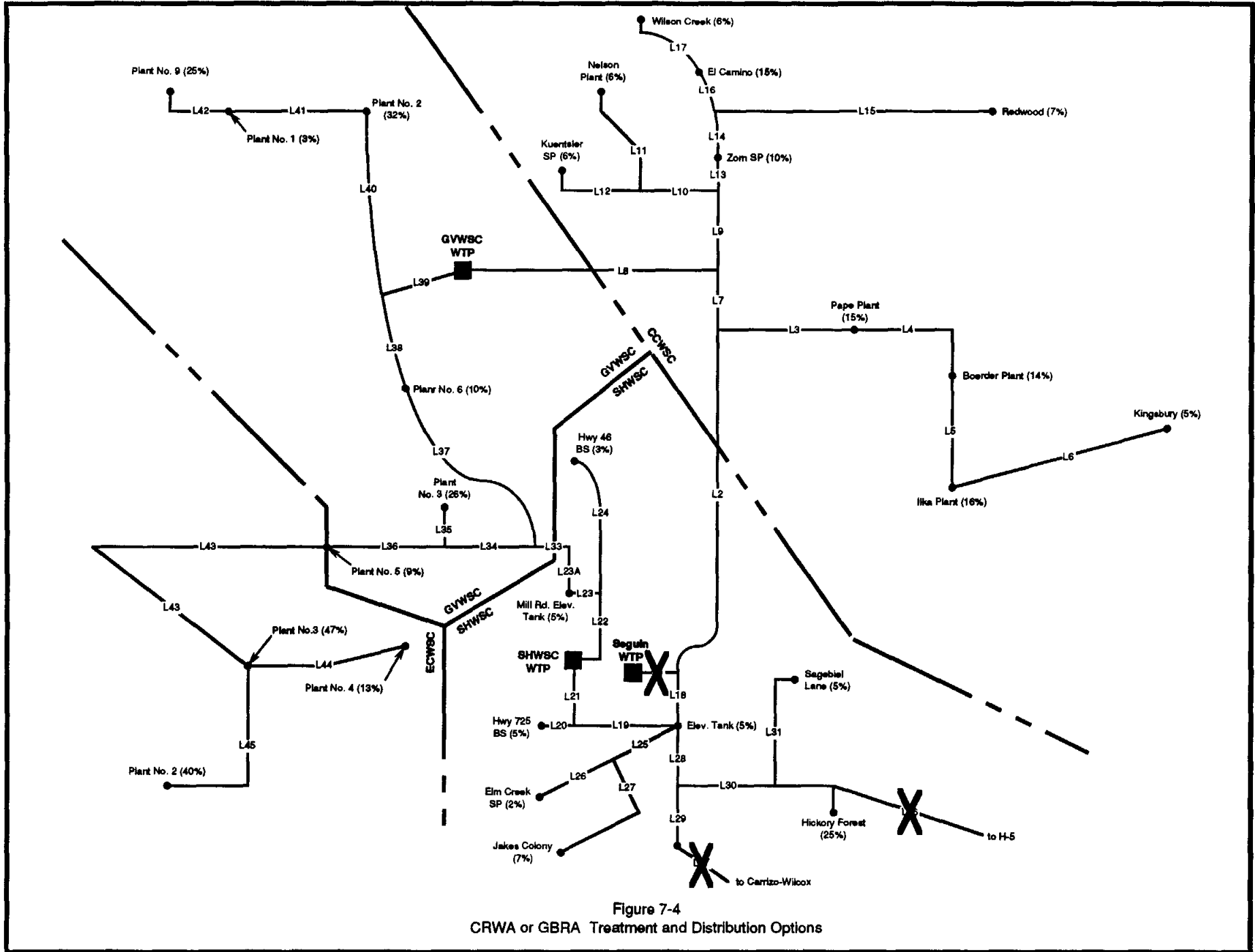

Figure 7-4  
CRWA or GBRA Treatment and Distribution Options

Table 7-18  
Phase I Installation of Major Transmission Mains  
Purchase Water From GBRA With CRWA Treatment (1990-2005)

Line Designation	Design Flow Rate (MGD)	Design Velocity (FPS)	Calculated Pipe Diameter (In)	Design Pipe Diameter (In)	Actual Velocity (FPS)	Approximate Pipe Length (Ft)	Pipe Unit Cost (\$/Ft)	Estimated Cost of Pipe (\$)
L1	-	-	-	-	-	400	-	-
L2	-	-	-	-	-	44,000	-	-
L3	0.92	5.0	7.2	8	4.1	8,600	8.00	\$68,800
L4	0.64	5.0	6.0	8	2.8	16,000	8.00	\$128,000
L5	0.38	5.0	4.7	8	1.7	30,000	8.00	\$240,000
L6	0.09	5.0	2.3	4	1.6	32,000	-	-
L7	0.92	5.0	7.2	8	4.1	5,000	8.00	\$40,000
L8	1.83	5.0	10.2	14	2.6	46,000	14.00	\$644,000
L9	0.92	5.0	7.2	8	4.1	14,000	8.00	\$112,000
L10	0.22	5.0	3.5	6	1.7	22,000	4.50	\$99,000
L11	0.11	5.0	2.5	4	1.9	22,000	-	-
L12	0.11	5.0	2.5	4	1.9	16,000	-	-
L13	0.70	5.0	6.3	8	3.1	15,000	8.00	\$120,000
L14	0.51	5.0	5.4	6	4.0	4,000	4.50	\$18,000
L15	0.13	5.0	2.7	4	2.3	17,000	-	-
L16	0.38	5.0	4.7	6	3.0	8,000	4.50	\$36,000
L17	0.11	5.0	2.5	4	1.9	22,000	-	-
L18	-	-	-	-	-	14,000	-	-
L19	0.21	5.0	3.4	4	3.7	8,000	-	-
L20	0.02	5.0	1.1	4	0.4	2,600	-	-
L21	0.23	5.0	3.6	4	4.1	4,600	-	-
L22	0.40	5.0	4.8	6	3.2	9,400	4.50	\$42,300
L23	0.42	5.0	4.9	6	3.3	7,000	4.50	\$31,500
L23A	0.44	5.0	5.0	6	3.5	800	4.50	\$3,600
L24	0.01	5.0	0.9	4	0.2	13,000	-	-
L25	0.04	5.0	1.5	4	0.7	22,000	-	-
L26	0.01	5.0	0.7	4	0.2	8,000	-	-
L27	0.03	5.0	1.3	4	0.5	50,000	-	-
L28	0.15	5.0	2.9	4	2.6	10,000	-	-
L29	0.01	5.0	0.9	4	0.2	11,000	-	-
L30	0.13	5.0	2.7	4	2.3	12,000	-	-
L31	0.02	5.0	1.1	4	0.4	16,000	-	-
L32	0.11	5.0	2.5	4	2.0	14,000	-	-
L32A	0.11	5.0	2.5	4	2.0	18,000	-	-
L33	0.21	5.0	3.4	4	3.7	6,000	-	-
L34	2.43	5.0	11.7	12	4.8	10,000	12.00	\$120,000
L35	0.42	5.0	4.9	6	3.3	4,000	4.50	\$18,000
L36	1.39	5.0	8.9	10	3.9	10,000	10.00	\$100,000
L37	2.25	5.0	11.3	12	4.4	8,000	12.00	\$96,000
L38	2.45	5.0	11.8	12	4.8	13,000	12.00	\$156,000
L39	3.64	5.0	14.4	16	4.0	5,300	16.00	\$84,800
L40	1.19	5.0	8.2	10	3.4	26,500	10.00	\$265,000
L41	0.56	5.0	5.6	8	2.5	31,500	8.00	\$252,000
L42	0.50	5.0	5.3	6	3.9	16,000	4.50	\$72,000
L43	1.21	5.0	8.3	12	2.4	42,000	12.00	\$504,000
L44	0.16	5.0	3.0	6	1.2	32,000	4.50	\$144,000
L45	0.48	5.0	5.2	8	2.1	18,000	8.00	\$144,000
L46	-	-	-	-	-	142,000	-	-
L47	-	-	-	-	-	50,000	-	-
<b>Total Estimated Major Line Cost</b>								<b>\$3,539,000</b>

Table 7-19  
Phase II Installation of Major Transmission Mains  
Purchase Water From GBRA with CRWA Treatment (2005-2020)

Line Designation	Design Flow Rate (MGD)	Design Velocity (FPS)	Calculated Pipe Diameter (In)	Design Pipe Diameter (In)	Actual Velocity (FPS)	Approximate Pipe Length (Ft)	Pipe Unit Cost (\$/Ft)	Estimated Cost of Pipe (\$)
L1	-	-	-	-	-	400	-	-
L2	-	-	-	-	-	44,000	-	-
L3	0.19	5.0	3.2	4	3.3	8,600	-	-
L4	0.13	5.0	2.7	4	2.3	16,000	-	-
L5	0.08	5.0	2.1	4	1.4	30,000	-	-
L6	0.02	5.0	1.0	4	0.3	32,000	-	-
L7	0.19	5.0	3.2	4	3.3	5,000	-	-
L8	0.37	5.0	4.6	8	1.6	46,000	8.00	\$368,000
L9	0.19	5.0	3.2	4	3.3	14,000	-	-
L10	0.04	5.0	1.6	4	0.8	22,000	-	-
L11	0.02	5.0	1.1	4	0.4	22,000	-	-
L12	0.02	5.0	1.1	4	0.4	16,000	-	-
L13	0.14	5.0	2.8	4	2.5	15,000	-	-
L14	0.10	5.0	2.4	4	1.8	4,000	-	-
L15	0.03	5.0	1.2	4	0.5	17,000	-	-
L16	0.08	5.0	2.1	4	1.4	8,000	-	-
L17	0.02	5.0	1.1	4	0.4	22,000	-	-
L18	-	-	-	-	-	14,000	-	-
L19	0.31	5.0	4.2	6	2.5	8,000	4.50	\$36,000
L20	0.03	5.0	1.4	4	0.6	2,500	-	-
L21	0.35	5.0	4.4	6	2.7	4,500	4.50	\$20,700
L22	0.62	5.0	5.9	6	4.9	9,400	4.50	\$42,300
L23	0.64	5.0	6.0	6	5.0	7,000	4.50	\$31,500
L23A	0.67	5.0	6.2	8	3.0	800	8.00	\$6,400
L24	0.02	5.0	1.1	4	0.4	13,000	-	-
L25	0.06	5.0	1.8	4	1.1	22,000	-	-
L26	0.01	5.0	0.9	4	0.2	8,000	-	-
L27	0.05	5.0	1.6	4	0.8	50,000	-	-
L28	0.22	5.0	3.5	4	3.9	10,000	-	-
L29	0.02	5.0	1.1	4	0.4	11,000	-	-
L30	0.20	5.0	3.4	4	3.6	12,000	-	-
L31	0.03	5.0	1.4	4	0.6	16,000	-	-
L32	0.17	5.0	3.1	4	3.0	14,000	-	-
L32A	0.17	5.0	3.1	6	1.3	18,000	4.50	\$81,000
L33	0.31	5.0	4.2	6	2.5	6,000	4.50	\$27,000
L34	0.53	5.0	5.5	6	4.2	10,000	4.50	\$45,000
L35	0.11	5.0	2.5	4	2.0	4,000	-	-
L36	1.15	5.0	8.1	10	3.3	10,000	10.00	\$100,000
L37	1.93	5.0	10.5	12	3.8	8,000	12.00	\$96,000
L38	1.99	5.0	10.6	12	3.9	13,000	12.00	\$156,000
L39	2.31	5.0	11.4	12	4.6	5,300	12.00	\$63,600
L40	0.32	5.0	4.3	6	2.6	26,500	4.50	\$119,250
L41	0.15	5.0	2.9	6	1.2	31,500	4.50	\$141,750
L42	0.14	5.0	2.8	4	2.4	16,000	-	-
L43	1.10	5.0	7.9	10	3.1	42,000	10.00	\$420,000
L44	0.14	5.0	2.8	6	1.1	32,000	4.50	\$144,000
L45	0.44	5.0	5.0	8	2.0	18,000	8.00	\$144,000
L46	-	-	-	-	-	142,000	-	-
L47	-	-	-	-	-	50,000	-	-
<b>Total Estimated Major Line Cost</b>								<b>\$2,042,500</b>

**Table 7-20**  
**Estimated Treatment Plant Costs**  
**Purchase Water From GBRA With CRWA Treatment a/**

Function	Total Cost						
	1990	1995	2000	2005	2010	2015	2020
1. Construction Cost							
a. Pumping Facilities	\$0	\$30,418	\$37,008	-	\$54,778	-	-
b. Treatment Works	\$2,500,000	\$1,824,979	\$2,220,368	-	\$3,286,685	-	-
c. Transmission Mains	\$0	\$0	\$0	-	\$0	-	-
2. Engineering b/	\$125,000	\$92,770	\$112,869	-	\$167,073	-	-
3. Land c/	\$100,000	\$0	\$0	-	\$0	-	-
4. Surveying and Staking d/	\$150,000	\$111,324	\$135,442	-	\$200,488	-	-
5. Legal and Administration e/	\$62,500	\$46,385	\$56,434	-	\$83,537	-	-
6. Permitting and Fees f/	\$50,000	\$37,108	\$45,147	-	\$66,829	-	-
7. Contingencies g/	\$250,000	\$185,540	\$225,737	-	\$334,146	-	-
<b>Total</b>	<b>\$3,237,500</b>	<b>\$2,328,522</b>	<b>\$2,833,003</b>	<b>-</b>	<b>\$4,193,536</b>	<b>-</b>	<b>-</b>

- a/ All costs assumes 1990 dollars inflated a 4% per year..  
b/ Assumes 5% of total construction cost.  
c/ Based on current estimated cost of \$5,000/acre.  
d/ Based on 3% of construction cost.  
e/ Based on 2.5% of construction cost.  
f/ Based on 2% of construction cost.  
g/ Based on 10% of construction costs.

**Table 7-21**  
**Estimated Transmission Line Costs**  
**Purchase Water From GBRA With CRWA Treatment a/**

Function	Total Cost						
	1990	1995	2000	2005	2010	2015	2020
1. Construction Cost							
a. Pumping Facilities	\$0	-	-	\$0	-	-	-
b. Treatment Works	\$0	-	-	\$0	-	-	-
c. Transmission Mains	\$3,539,000	-	-	\$3,678,427	-	-	-
2. Engineering b/	\$178,950	-	-	\$183,921	-	-	-
3. Land c/	\$0	-	-	\$0	-	-	-
4. Surveying and Staking d/	\$212,340	-	-	\$220,706	-	-	-
5. Legal and Administration e/	\$68,475	-	-	\$91,961	-	-	-
6. Permitting and Fees f/	\$70,780	-	-	\$73,569	-	-	-
7. Contingencies g/	\$353,900	-	-	\$367,843	-	-	-
<b>Total</b>	<b>\$4,441,445</b>	<b>-</b>	<b>-</b>	<b>\$4,616,426</b>	<b>-</b>	<b>-</b>	<b>-</b>

- a/ All costs assumes 1990 dollars inflated a 4% per year..  
b/ Assumes 5% of total construction cost.  
c/ Based on current estimated cost of \$5,000/acre.  
d/ Based on 3% of construction cost.  
e/ Based on 2.5% of construction cost.  
f/ Based on 2% of construction cost.  
g/ Based on 10% of construction costs.



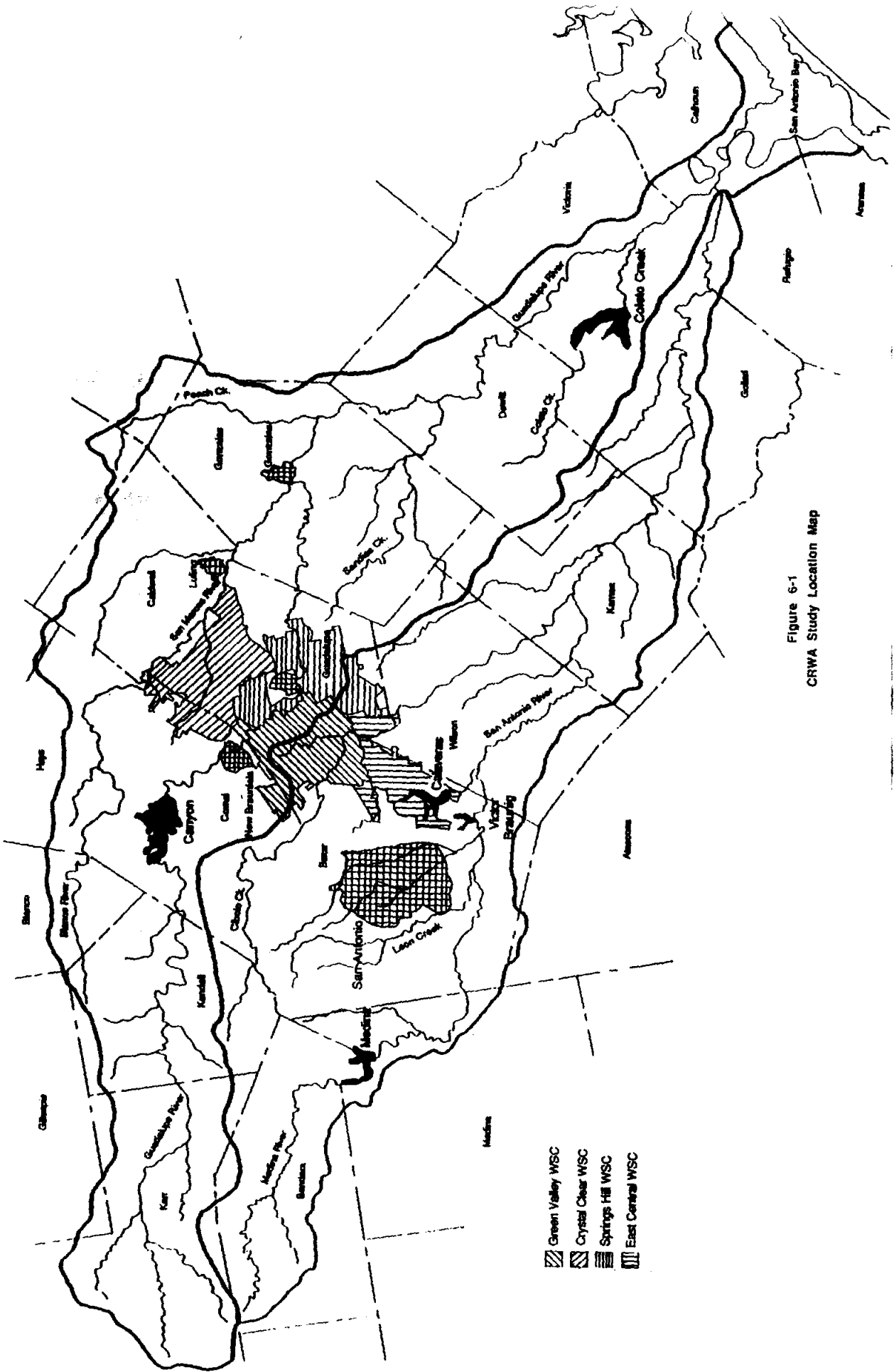

Figure 6-1  
CRWA Study Location Map





-  Green Valley WSC
-  Crystal Clear WSC
-  Springs Hill WSC
-  East Central WSC

Table 7-22  
 Cost Analysis of CRWA Purchase, Treatment and Distribution Option  
 (2,250 AF/yr Purchase Increment)

Year	Capital Plant a/	O&M Plant b/	Capital Plant c/	O&M Plant b/	Capital Plant d/	O&M Plant b/	Capital Plant e/	O&M Plant b/	Trmnt Cost	Capital Line f/	O&M Line g/	Capital Line h/	O&M Line g/	Line Cost	Demand (MGD)	Purchased (MGD)	Cost of Water V	Total Cost	Cumulative Cost	Cost/1,000 gal. Treated
1990	287,579	125,000							412,579	394,522	176,950			571,472	1.44	2.00	98,560	1,082,611	1,082,611	2.06
1991	287,579	130,000							417,579	394,522	184,028			578,550	1.88	2.00	98,560	1,084,699	2,177,300	1.59
1992	287,579	135,200							422,779	394,522	191,389			585,911	2.32	2.00	98,560	1,107,250	3,284,550	1.31
1993	287,579	140,808							428,187	394,522	199,045			593,567	2.77	2.00	98,560	1,120,314	4,404,864	1.11
1994	287,579	146,232							433,811	394,522	207,006			601,529	3.21	2.00	98,560	1,133,900	5,538,783	0.97
1995	287,579	152,062	206,837	92,770					738,267	394,522	215,287			609,809	3.65	4.00	239,827	1,588,903	7,127,666	1.19
1996	287,579	158,165	206,837	96,481					749,061	394,522	223,898			618,420	3.84	4.00	239,827	1,607,308	8,734,974	1.15
1997	287,579	164,491	206,837	100,340					759,247	394,522	232,854			627,378	4.02	4.00	239,827	1,626,450	10,361,424	1.11
1998	287,579	171,071	206,837	104,354					769,840	394,522	242,168			636,690	4.21	4.00	239,827	1,646,357	12,007,781	1.07
1999	287,579	177,914	206,837	108,528					780,857	394,522	251,855			646,377	4.39	4.00	239,827	1,667,081	13,674,842	1.04
2000	287,579	185,031	206,837	112,869	251,648	112,870			1,156,833	394,522	261,929			656,451	4.58	6.00	359,740	2,173,024	15,847,867	1.30
2001	287,579	192,432	206,837	117,384	251,648	117,385			1,173,264	394,522	272,406			666,929	4.76	6.00	359,740	2,199,932	18,047,799	1.27
2002	287,579	200,129	206,837	122,079	251,648	122,080			1,190,352	394,522	283,303			677,825	4.94	6.00	359,740	2,227,917	20,275,715	1.24
2003	287,579	208,134	206,837	126,962	251,648	126,963			1,208,123	394,522	294,635			689,157	5.11	6.00	359,740	2,257,020	22,532,736	1.21
2004	287,579	216,460	206,837	132,041	251,648	132,042			1,226,606	394,522	306,420			700,942	5.29	6.00	359,740	2,287,268	24,820,023	1.18
2005	287,579	225,118	206,837	137,322	251,648	137,324			1,245,827	394,522	318,677	410,065	183,920	1,307,184	5.47	6.00	532,503	3,085,515	27,905,538	1.55
2006	287,579	234,123	206,837	142,815	251,648	142,817			1,265,818	394,522	331,424	410,065	191,277	1,327,296	5.63	6.00	532,503	3,125,609	31,031,147	1.52
2007	287,579	243,488	206,837	148,528	251,648	148,529			1,286,608	394,522	344,681	410,065	198,928	1,348,196	5.80	6.00	532,503	3,167,307	34,198,455	1.50
2008	287,579	253,227	206,837	154,469	251,648	154,470			1,308,230	394,522	358,468	410,065	206,866	1,369,941	5.96	6.00	532,503	3,210,674	37,409,128	1.48
2009	287,579	263,356	206,837	160,648	251,648	160,649			1,330,717	394,522	372,907	410,065	215,180	1,392,556	6.13	6.00	532,503	3,255,774	40,664,903	1.46
2010	287,579	273,890	206,837	167,074	251,648	167,075	372,501	167,073	1,893,677	394,522	387,719	410,065	223,767	1,416,073	6.29	8.00	710,004	4,019,754	44,684,657	1.75
2011	287,579	284,846	206,837	173,756	251,648	173,758	372,501	173,756	1,924,681	394,522	403,228	410,065	232,717	1,440,533	6.38	8.00	710,004	4,075,218	48,759,875	1.75
2012	287,579	296,240	206,837	180,707	251,648	180,709	372,501	180,706	1,956,926	394,522	419,357	410,065	242,026	1,465,971	6.47	8.00	710,004	4,132,901	52,892,775	1.75
2013	287,579	308,089	206,837	187,935	251,648	187,937	372,501	187,934	1,990,460	394,522	436,131	410,065	251,707	1,482,426	6.57	8.00	710,004	4,192,890	57,085,666	1.75
2014	287,579	320,413	206,837	195,452	251,648	195,454	372,501	195,452	2,025,336	394,522	453,577	410,065	261,776	1,519,940	6.66	8.00	710,004	4,255,280	61,340,945	1.75
2015	287,579	333,230	206,837	203,270	251,648	203,272	372,501	203,270	2,061,607	394,522	471,720	410,065	272,247	1,548,554	6.75	8.00	1,050,979	4,661,140	66,002,085	1.89
2016	287,579	346,599	206,837	211,401	251,648	211,403	372,501	211,401	2,099,329	394,522	490,589	410,065	283,136	1,578,312	6.99	8.00	1,050,979	4,728,620	70,730,706	1.85
2017	287,579	360,421	206,837	219,857	251,648	219,860	372,501	219,857	2,138,598	394,522	510,212	410,065	294,462	1,609,261	7.24	8.00	1,050,979	4,798,800	75,529,506	1.82
2018	287,579	374,838	206,837	228,652	251,648	228,654	372,501	228,651	2,179,359	394,522	530,621	410,065	306,240	1,641,448	7.48	8.00	1,050,979	4,871,787	80,401,292	1.78
2019	287,579	389,831	206,837	237,798	251,648	237,800	372,501	237,797	2,221,791	394,522	551,845	410,065	318,490	1,674,923	7.73	8.00	1,050,979	4,947,893	85,348,985	1.75
2020		405,425	206,837	247,310	251,648	247,312	372,501	247,309	1,978,341		573,919	410,065	331,230	1,315,214	7.97	8.00	1,050,979	4,344,534	89,693,520	1.49

a/ Based on an initial capital expenditure of \$3,237,500 in 1990 and amortized at 8% APR for 30 years.  
 b/ 0.05% of construction cost inflated at 4% per year.  
 c/ Based on a capital expenditure of \$1,913,900 (1990 dollars) inflated at 4% per year to 1995 (\$2,328,522) and amortized at 8% APR for 30 years.  
 d/ Based on a capital expenditure of \$1,913,900 (1990 dollars) inflated at 4% per year to 2000 (\$2,833,000) and amortized at 8% APR for 30 years.  
 e/ Based on a capital expenditure of \$1,913,900 (1990 dollars) inflated at 4% per year to 2010 (\$4,193,500) and amortized at 8% APR for 30 years.  
 f/ Based on an initial capital expenditure of \$4,441,445 in 1990 and amortized at 8% APR for 30 years.  
 g/ 0.05% of construction cost inflated at 4% per year.  
 h/ Based on a capital expenditure of \$2,583,300 (1990 dollars) inflated at 4% per year to 2005 (\$4,616,426) and amortized at 8% APR for 30 years.  
 i/ Based on \$44/AF inflated at 4% per year.

Table 7-23  
 Cost Analysis of CRWA Purchase, Treatment and Distribution Option  
 (4,500 AF/yr Purchase Increment)

Year	Capital Plant a/	O&M Plant b/	Capital Plant c/	O&M Plant b/	Capital Plant d/	O&M Plant b/	Capital Plant e/	O&M Plant b/	Trmnt Cost	Capital Line f/	O&M Line g/	Capital Line h/	O&M Line g/	Line Cost	Demand (MGD)	Purchased (MGD)	Cost of Water v/	Total Cost	Cumulative Cost	Cost/1,000 gal. Treated
1990	287,579	125,000							412,579	394,522	176,950			571,472	1.44	4.00	197,120	1,181,171	1,181,171	2.25
1991	287,579	130,000							417,579	394,522	184,028			578,550	1.88	4.00	197,120	1,193,249	2,374,420	1.74
1992	287,579	135,200							422,779	394,522	191,389			585,911	2.32	4.00	197,120	1,205,810	3,580,230	1.42
1993	287,579	140,608							428,187	394,522	199,045			593,567	2.77	4.00	197,120	1,218,874	4,799,104	1.21
1994	287,579	146,232							433,811	394,522	207,006			601,529	3.21	4.00	197,120	1,232,480	6,031,563	1.05
1995	287,579	152,062	206,837	92,770					739,267	394,522	215,287			609,809	3.66	4.00	239,827	1,588,903	7,620,466	1.19
1996	287,579	158,165	206,837	96,481					749,061	394,522	223,898			618,420	3.84	4.00	239,827	1,607,308	9,227,774	1.15
1997	287,579	164,491	206,837	100,340					759,247	394,522	232,854			627,375	4.02	4.00	239,827	1,626,450	10,854,224	1.11
1998	287,579	171,071	206,837	104,354					769,840	394,522	242,188			636,690	4.21	4.00	239,827	1,646,357	12,500,581	1.07
1999	287,579	177,914	206,837	108,528					780,857	394,522	251,855			646,377	4.39	4.00	239,827	1,667,061	14,167,642	1.04
2000	287,579	185,031	206,837	112,869	251,648	112,870			1,156,833	394,522	261,929			656,451	4.58	8.00	479,653	2,292,938	16,460,580	1.37
2001	287,579	192,432	206,837	117,384	251,648	117,385			1,173,264	394,522	272,406			666,929	4.76	8.00	479,653	2,319,846	18,780,425	1.34
2002	287,579	200,129	206,837	122,079	251,648	122,080			1,190,352	394,522	283,303			677,825	4.94	8.00	479,653	2,347,830	21,128,255	1.30
2003	287,579	208,134	206,837	126,962	251,648	126,963			1,208,123	394,522	294,635			689,157	5.11	8.00	479,653	2,376,933	23,505,189	1.27
2004	287,579	216,460	206,837	132,041	251,648	132,042			1,226,606	394,522	306,420			700,942	5.29	8.00	479,653	2,407,201	25,912,390	1.25
2005	287,579	225,118	206,837	137,322	251,648	137,324			1,245,827	394,522	318,677	410,065	183,920	1,307,184	5.47	8.00	710,004	3,263,016	29,175,406	1.63
2006	287,579	234,123	206,837	142,815	251,648	142,817			1,265,818	394,522	331,424	410,065	191,277	1,327,288	5.63	8.00	710,004	3,303,110	32,478,516	1.61
2007	287,579	243,488	206,837	148,528	251,648	148,529			1,286,608	394,522	344,681	410,065	198,928	1,348,196	5.80	8.00	710,004	3,344,808	35,823,324	1.58
2008	287,579	253,227	206,837	154,469	251,648	154,470			1,308,230	394,522	358,468	410,065	206,885	1,369,941	5.96	8.00	710,004	3,388,175	39,211,499	1.56
2009	287,579	263,356	206,837	160,648	251,648	160,649			1,330,717	394,522	372,807	410,065	215,160	1,392,555	6.13	8.00	710,004	3,433,275	42,644,774	1.54
2010	287,579	273,890	206,837	167,074	251,648	167,075	372,501	187,073	1,893,677	394,522	387,719	410,065	223,767	1,418,073	6.29	8.00	710,004	4,019,754	46,664,528	1.75
2011	287,579	284,846	206,837	173,756	251,648	173,758	372,501	173,756	1,924,681	394,522	403,228	410,065	232,717	1,446,533	6.38	8.00	710,004	4,075,218	50,739,746	1.75
2012	287,579	296,240	206,837	180,707	251,648	180,708	372,501	180,706	1,956,926	394,522	419,357	410,065	242,026	1,485,971	6.47	8.00	710,004	4,132,901	54,872,647	1.75
2013	287,579	308,089	206,837	187,935	251,648	187,937	372,501	187,934	1,990,460	394,522	436,131	410,065	251,707	1,492,426	6.57	8.00	710,004	4,192,890	59,065,537	1.75
2014	287,579	320,413	206,837	195,452	251,648	195,454	372,501	195,452	2,025,336	394,522	453,577	410,065	261,776	1,519,940	6.66	8.00	710,004	4,255,280	63,320,817	1.75
2015	287,579	333,230	206,837	203,270	251,648	203,272	372,501	203,270	2,061,607	394,522	471,720	410,065	272,247	1,548,554	6.75	8.00	1,050,979	4,561,140	67,981,957	1.89
2016	287,579	346,559	206,837	211,401	251,648	211,403	372,501	211,401	2,099,329	394,522	490,589	410,065	283,136	1,578,312	6.99	8.00	1,050,979	4,728,620	72,710,577	1.85
2017	287,579	360,421	206,837	219,857	251,648	219,860	372,501	219,857	2,138,559	394,522	510,212	410,065	294,462	1,606,281	7.24	8.00	1,050,979	4,798,800	77,509,377	1.82
2018	287,579	374,838	206,837	228,652	251,648	228,654	372,501	228,651	2,179,359	394,522	530,621	410,065	306,240	1,641,448	7.48	8.00	1,050,979	4,871,787	82,381,164	1.78
2019	287,579	389,831	206,837	237,798	251,648	237,800	372,501	237,797	2,221,791	394,522	551,845	410,065	318,490	1,674,823	7.73	8.00	1,050,979	4,947,693	87,328,857	1.75
2020		405,425	206,837	247,310	251,648	247,312	372,501	247,308	1,978,341		573,919	410,065	331,230	1,315,214	7.97	8.00	1,050,979	4,344,534	91,673,391	1.49

a/ Based on an initial capital expenditure of \$3,237,500 in 1990 and amortized at 8% APR for 30 years.

b/ 0.05% of construction cost inflated at 4% per year.

c/ Based on a capital expenditure of \$1,913,900 (1990 dollars) inflated at 4% per year to 1995 (\$2,328,522) and amortized at 8% APR for 30 years.

d/ Based on a capital expenditure of \$1,913,900 (1990 dollars) inflated at 4% per year to 2000 (\$2,833,000) and amortized at 8% APR for 30 years.

e/ Based on a capital expenditure of \$1,913,900 (1990 dollars) inflated at 4% per year to 2010 (\$4,193,500) and amortized at 8% APR for 30 years.

f/ Based on an initial capital expenditure of \$4,441,445 in 1990 and amortized at 8% APR for 30 years.

g/ 0.05% of construction cost inflated at 4% per year.

h/ Based on a capital expenditure of \$2,563,300 (1990 dollars) inflated at 4% per year to 2005 (\$4,616,426) and amortized at 8% APR for 30 years.

v/ Based on \$44/AF inflated at 4% per year.

Table 7-24  
 Cost Analysis of CRWA Purchase, Treatment and Distribution Option  
 (9,000 AF/yr Purchase Increment)

Year	Capital Plant a/	O&M Plant b/	Capital Plant c/	O&M Plant b/	Capital Plant d/	O&M Plant b/	Capital Plant e/	O&M Plant b/	Trmnt Cost	Capital Line f/	O&M Line g/	Capital Line h/	O&M Line g/	Line Cost	Demand (MGD)	Purchased (MGD)	Cost of Water i/	Total Cost	Cumulative Cost	Cost/1,000 gal. Treated
1990	287,579	125,000							412,579	394,522	176,950			571,472	1.44	8.00	394,240	1,378,291	1,378,291	2.62
1991	287,579	130,000							417,579	394,522	184,028			578,550	1.88	8.00	394,240	1,390,369	2,768,660	2.02
1992	287,579	135,200							422,779	394,522	191,389			585,911	2.32	8.00	394,240	1,402,930	4,171,590	1.65
1993	287,579	140,608							428,187	394,522	199,046			593,567	2.77	8.00	394,240	1,415,994	5,587,584	1.40
1994	287,579	146,232							433,811	394,522	207,006			601,529	3.21	8.00	394,240	1,429,580	7,017,163	1.22
1995	287,579	152,082	206,837	92,770					739,267	394,522	215,287			609,809	3.65	8.00	479,653	1,828,729	8,845,893	1.37
1996	287,579	158,165	206,837	96,481					749,061	394,522	223,898			618,420	3.94	8.00	479,653	1,847,135	10,693,027	1.32
1997	287,579	164,491	206,837	100,340					759,247	394,522	232,854			627,376	4.02	8.00	479,653	1,866,276	12,559,304	1.27
1998	287,579	171,071	206,837	104,354					769,840	394,522	242,168			636,690	4.21	8.00	479,653	1,886,184	14,445,488	1.23
1999	287,579	177,914	206,837	108,528					780,857	394,522	251,855			646,377	4.39	8.00	479,653	1,906,888	16,352,375	1.19
2000	287,579	185,031	206,837	112,869	251,648	112,870			1,156,833	394,522	261,929			656,451	4.58	8.00	479,653	2,229,939	18,645,313	1.37
2001	287,579	192,432	206,837	117,384	251,648	117,385			1,173,264	394,522	272,408			666,929	4.76	8.00	479,653	2,319,846	20,965,159	1.34
2002	287,579	200,129	206,837	122,079	251,648	122,080			1,190,352	394,522	283,303			677,825	4.94	8.00	479,653	2,347,830	23,312,968	1.30
2003	287,579	208,134	206,837	126,962	251,648	126,963			1,208,123	394,522	294,635			689,157	5.11	8.00	479,653	2,376,833	25,689,922	1.27
2004	287,579	216,480	206,837	132,041	251,648	132,042			1,226,606	394,522	306,420			700,942	5.29	8.00	479,653	2,407,201	28,097,123	1.25
2005	287,579	225,118	206,837	137,322	251,648	137,324			1,245,827	394,522	318,677	410,065	183,920	1,307,184	5.47	8.00	710,004	3,263,016	31,360,139	1.83
2006	287,579	234,123	206,837	142,815	251,648	142,817			1,265,818	394,522	331,424	410,065	191,277	1,327,298	5.63	8.00	710,004	3,303,110	34,663,249	1.61
2007	287,579	243,488	206,837	148,528	251,648	148,529			1,286,608	394,522	344,681	410,065	198,928	1,348,196	5.80	8.00	710,004	3,344,808	38,008,057	1.58
2008	287,579	253,227	206,837	154,469	251,648	154,470			1,308,230	394,522	358,468	410,065	206,885	1,369,941	5.96	8.00	710,004	3,388,175	41,396,232	1.56
2009	287,579	263,356	206,837	160,648	251,648	160,649			1,330,717	394,522	372,807	410,065	215,160	1,392,555	6.13	8.00	710,004	3,433,275	44,829,507	1.54
2010	287,579	273,890	206,837	167,074	251,648	167,075	372,501	167,073	1,893,677	394,522	387,719	410,065	223,767	1,416,073	6.29	8.00	710,004	4,019,754	48,849,261	1.75
2011	287,579	284,846	206,837	173,756	251,648	173,758	372,501	173,756	1,924,681	394,522	403,228	410,065	232,717	1,440,533	6.38	8.00	710,004	4,075,218	52,924,479	1.75
2012	287,579	296,240	206,837	180,707	251,648	180,709	372,501	180,706	1,958,928	394,522	419,357	410,065	242,026	1,465,971	6.47	8.00	710,004	4,132,901	57,057,380	1.75
2013	287,579	308,089	206,837	187,935	251,648	187,937	372,501	187,934	1,990,460	394,522	436,131	410,065	251,707	1,492,426	6.57	8.00	710,004	4,192,890	61,250,270	1.75
2014	287,579	320,413	206,837	195,452	251,648	195,454	372,501	195,452	2,025,336	394,522	453,577	410,065	261,776	1,519,940	6.66	8.00	710,004	4,255,280	65,505,550	1.75
2015	287,579	333,230	206,837	203,270	251,648	203,272	372,501	203,270	2,061,607	394,522	471,720	410,065	272,247	1,548,554	6.75	8.00	1,050,979	4,661,140	70,166,690	1.89
2016	287,579	346,559	206,837	211,401	251,648	211,403	372,501	211,401	2,098,329	394,522	490,589	410,065	283,136	1,578,312	6.99	8.00	1,050,979	4,728,620	74,895,310	1.85
2017	287,579	360,421	206,837	219,857	251,648	219,860	372,501	219,857	2,138,559	394,522	510,212	410,065	294,462	1,609,261	7.24	8.00	1,050,979	4,798,800	79,694,110	1.82
2018	287,579	374,838	206,837	228,652	251,648	228,654	372,501	228,651	2,179,399	394,522	530,621	410,065	306,240	1,641,448	7.48	8.00	1,050,979	4,871,787	84,565,897	1.78
2019	287,579	389,831	206,837	237,798	251,648	237,800	372,501	237,797	2,221,791	394,522	551,845	410,065	318,490	1,674,823	7.73	8.00	1,050,979	4,947,693	89,513,590	1.75
2020		405,425	206,837	247,310	251,648	247,312	372,501	247,309	1,978,341		573,919	410,065	331,230	1,315,214	7.97	8.00	1,050,979	4,344,534	93,858,124	1.49

- a/ Based on an initial capital expenditure of \$3,237,500 in 1990 and amortized at 8% APR for 30 years.
- b/ 0.05% of construction cost inflated at 4% per year.
- c/ Based on a capital expenditure of \$1,913,900 (1990 dollars) inflated at 4% per year to 1995 (\$2,328,522) and amortized at 8% APR for 30 years.
- d/ Based on a capital expenditure of \$1,913,900 (1990 dollars) inflated at 4% per year to 2000 (\$2,833,000) and amortized at 8% APR for 30 years.
- e/ Based on a capital expenditure of \$1,913,900 (1990 dollars) inflated at 4% per year to 2010 (\$4,193,500) and amortized at 8% APR for 30 years.
- f/ Based on an initial capital expenditure of \$4,441,445 in 1990 and amortized at 8% APR for 30 years.
- g/ 0.05% of construction cost inflated at 4% per year.
- h/ Based on a capital expenditure of \$2,563,300 (1990 dollars) inflated at 4% per year to 2005 (\$4,616,426) and amortized at 8% APR for 30 years.
- i/ Based on \$44/AF inflated at 4% per year.

**Figure 7-5**  
**Cost/1,000 gal of Water Purchased from GBRA and Treated in a CRWA Facility**  
**Assuming 2,250, 4,500 and 9,000 AF/yr Purchase Increments**

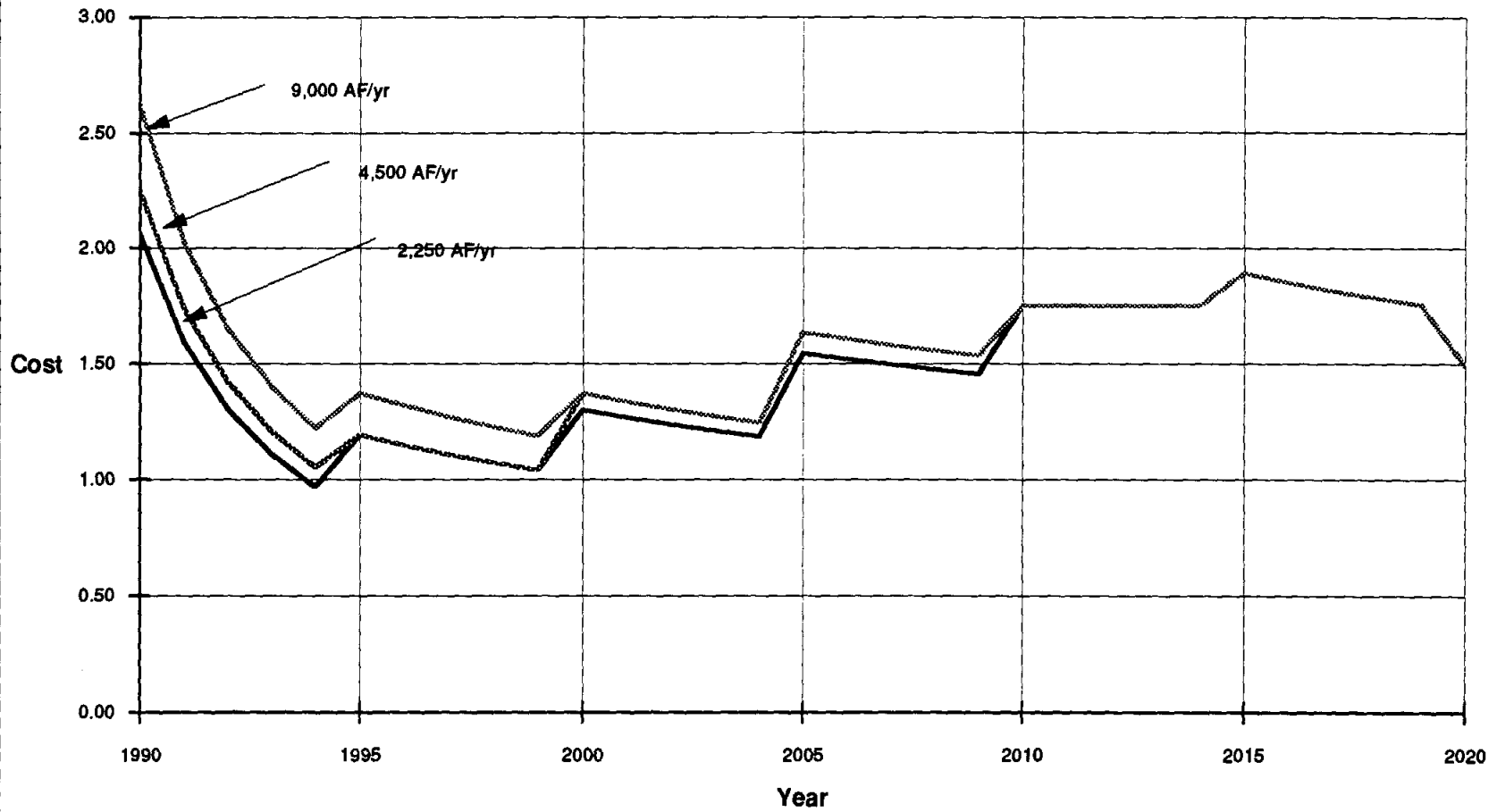

**Figure 7-6**  
**Total Annual Cost of Water Purchased from GBRA and Treated in a CRWA Facility**  
**Assuming 2,250, 4,500 and 9,000 AF/yr Purchase Increments**

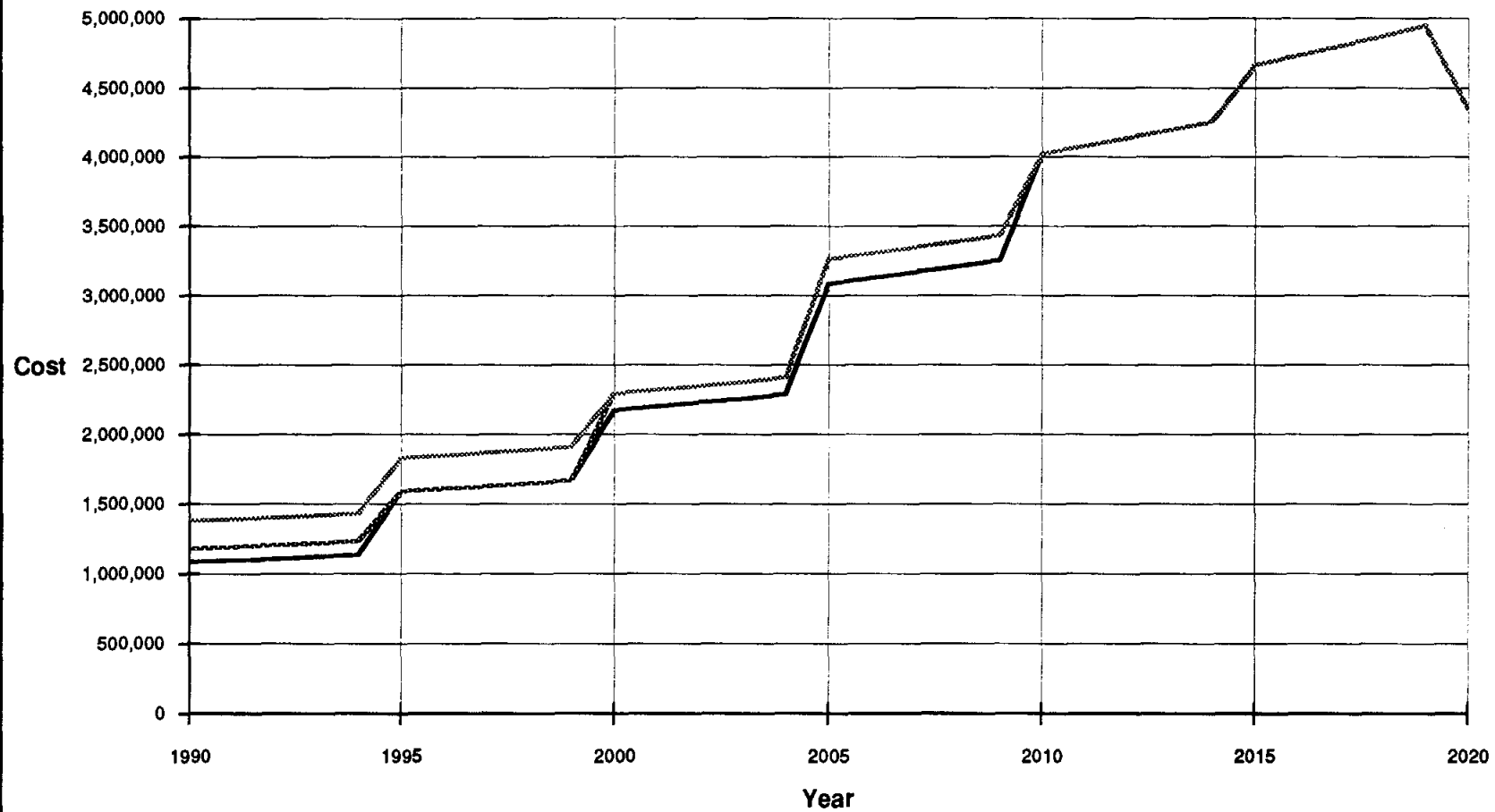

**Figure 7-7**  
**Cumulative Cost of Water Purchased from GBRA and Treated in a CRWA Facility**  
**Assuming 2,250, 4,500 and 9,000 AF/yr Purchase Increments**

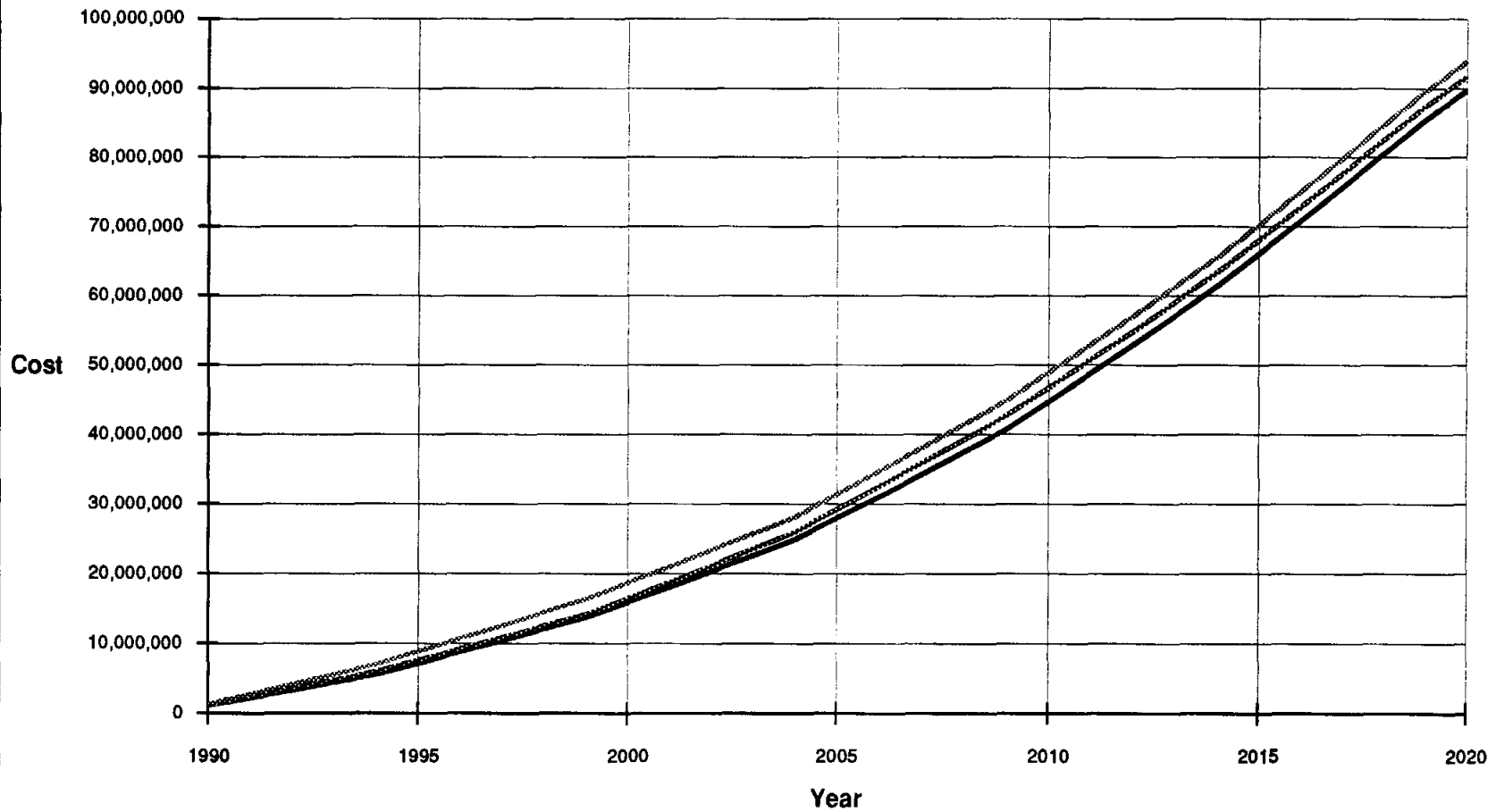

### 7.8.2 Option 2 - Purchase Treated Water from GBRA

Option 2 assumes that the CRWA purchase treated water from a GBRA operated surface water treatment facility located below Dittmar Falls. The CRWA would be responsible for providing the transmission main system (also Figure 7-4). The transmission main layout for this option is identical to that described in Option 1. Lines L1, L2, L18, L46, and L47 are not used in this option. Service is split in two directions: toward Crystal Clear WSC along Hwy 758 (line L8); and, to the remaining WSCs via line L39. Table 7-25 summarizes flows, pipe sizes, and estimated costs for individual sections of the transmission main system for the initial phase of line installation. Estimated transmission main construction costs for Phase I is \$3,539,000. Estimated transmission main construction costs for Phase II is \$2,042,500. Table 7-26 summarizes the second phase of line installation.

Total costs for Option 2 phased installation of treatment and distribution facilities, taken forward at an annual inflation rate of 4% per year to the actual date of expenditure, are shown in Tables 7-27 and 7-28. Total annualized cost for Option 2 installation, is shown in Tables 7-29. Total CRWA cost per 1,000 gal, total annual costs and total cumulative costs (all assuming no rate-leveling financing mechanisms in place) for Option 2 are shown in Figures 7-8 through 7-10.

### 7.8.3 Option 3 - Purchase Water from GBRA with Treatment by the City of Seguin

Option 3 assumes that excess treatment capacity is purchased from the City of Seguin through 2005 and that the CRWA constructs a surface water treatment facility below Dittmar Falls during the first five year planning period. Figure 7-11 illustrates schematically the transmission system necessary to provide service throughout the CRWA service area. Lines L 46 and L 47 are not used in this option. The system is supplied in two directions. Crystal Clear WSC is supplied by a line extending north along Hwy 123 (line L2). Line L2 is sized to provide service to Crystal Clear through 1995, at which time water would be supplied along Hwy 758 from the Dittmar Falls plant. After 1995, Line L2 would serve as an emergency interconnect between Crystal Clear WSC and Springs Hill WSC. Table 7-30 summarizes flows, pipe sizes, and estimated costs for individual sections of the transmission main system for the initial phase of line installation. Estimated transmission main construction costs for Phase I is \$4,502,800. Estimated transmission main construction costs for Phase II is \$1,247,000. Table 7-31 summarizes the second phase of line installation.

Total costs for Option 3 phased installation of treatment and distribution facilities, taken forward at an annual inflation rate of 4% per year to the actual date of expenditure, are shown in Tables 7-32 and 7-33. Total annualized cost for Option 3 installation, including the cost of water under three possible take-or-pay options (2,250 AF/yr, 4,500 AF/yr, and 9,000 AF/yr) are shown in Tables 7-34 through 7-36. Total CRWA



**Table 7-25**  
**Phase I Installation of Major Transmission Mains**  
**Purchase Treated Water From GBRA (1990-2005)**

Line Designation	Design Flow Rate (MGD)	Design Velocity (FPS)	Calculated Pipe Diameter (In)	Design Pipe Diameter (In)	Actual Velocity (FPS)	Approximate Pipe Length (Ft)	Pipe Unit Cost (\$/Ft)	Estimated Cost of Pipe (\$)
L1	-	-	-	-	-	400	-	-
L2	-	-	-	-	-	44,000	-	-
L3	0.92	5.0	7.2	8	4.1	8,600	8.00	\$68,800
L4	0.64	5.0	6.0	8	2.8	16,000	8.00	\$128,000
L5	0.38	5.0	4.7	8	1.7	30,000	8.00	\$240,000
L6	0.09	5.0	2.3	4	1.6	32,000	-	-
L7	0.92	5.0	7.2	8	4.1	5,000	8.00	\$40,000
L8	1.83	5.0	10.2	14	2.6	46,000	14.00	\$644,000
L9	0.92	5.0	7.2	8	4.1	14,000	8.00	\$112,000
L10	0.22	5.0	3.5	6	1.7	22,000	4.50	\$99,000
L11	0.11	5.0	2.5	4	1.9	22,000	-	-
L12	0.11	5.0	2.5	4	1.9	16,000	-	-
L13	0.70	5.0	6.3	8	3.1	15,000	8.00	\$120,000
L14	0.51	5.0	5.4	6	4.0	4,000	4.50	\$18,000
L15	0.13	5.0	2.7	4	2.3	17,000	-	-
L16	0.38	5.0	4.7	6	3.0	8,000	4.50	\$36,000
L17	0.11	5.0	2.5	4	1.9	22,000	-	-
L18	-	-	-	-	-	14,000	-	-
L19	0.21	5.0	3.4	4	3.7	8,000	-	-
L20	0.02	5.0	1.1	4	0.4	2,600	-	-
L21	0.23	5.0	3.6	4	4.1	4,600	-	-
L22	0.40	5.0	4.8	6	3.2	9,400	4.50	\$42,300
L23	0.42	5.0	4.9	6	3.3	7,000	4.50	\$31,500
L23A	0.44	5.0	5.0	6	3.5	800	4.50	\$3,600
L24	0.01	5.0	0.9	4	0.2	13,000	-	-
L25	0.04	5.0	1.5	4	0.7	22,000	-	-
L26	0.01	5.0	0.7	4	0.2	8,000	-	-
L27	0.03	5.0	1.3	4	0.5	50,000	-	-
L28	0.15	5.0	2.9	4	2.6	10,000	-	-
L29	0.01	5.0	0.9	4	0.2	11,000	-	-
L30	0.13	5.0	2.7	4	2.3	12,000	-	-
L31	0.02	5.0	1.1	4	0.4	16,000	-	-
L32	0.11	5.0	2.5	4	2.0	14,000	-	-
L32A	0.11	5.0	2.5	4	2.0	18,000	-	-
L33	0.21	5.0	3.4	4	3.7	6,000	-	-
L34	2.43	5.0	11.7	12	4.8	10,000	12.00	\$120,000
L35	0.42	5.0	4.9	6	3.3	4,000	4.50	\$18,000
L36	1.39	5.0	8.9	10	3.9	10,000	10.00	\$100,000
L37	2.25	5.0	11.3	12	4.4	8,000	12.00	\$96,000
L38	2.45	5.0	11.8	12	4.8	13,000	12.00	\$156,000
L39	3.64	5.0	14.4	16	4.0	5,300	16.00	\$84,800
L40	1.19	5.0	8.2	10	3.4	26,500	10.00	\$265,000
L41	0.56	5.0	5.6	8	2.5	31,500	8.00	\$252,000
L42	0.50	5.0	5.3	6	3.9	16,000	4.50	\$72,000
L43	1.21	5.0	8.3	12	2.4	42,000	12.00	\$504,000
L44	0.16	5.0	3.0	6	1.2	32,000	4.50	\$144,000
L45	0.48	5.0	5.2	8	2.1	18,000	8.00	\$144,000
L46	-	-	-	-	-	142,000	-	-
L47	-	-	-	-	-	50,000	-	-
<b>Total Estimated Major Line Cost</b>								<b>\$3,539,000</b>

**Table 7-26**  
**Phase II Installation of Major Transmission Mains**  
**Purchase Treated Water From GBRA (2005-2020)**

Line Designation	Design Flow Rate (MGD)	Design Velocity (FPS)	Calculated Pipe Diameter (In)	Design Pipe Diameter (In)	Actual Velocity (FPS)	Approximate Pipe Length (Ft)	Pipe Unit Cost (\$/Ft)	Estimated Cost of Pipe (\$)
L1	-	-	-	-	-	400	-	-
L2	-	-	-	-	-	44,000	-	-
L3	0.19	5.0	3.2	4	3.3	8,600	-	-
L4	0.13	5.0	2.7	4	2.3	16,000	-	-
L5	0.08	5.0	2.1	4	1.4	30,000	-	-
L6	0.02	5.0	1.0	4	0.3	32,000	-	-
L7	0.19	5.0	3.2	4	3.3	5,000	-	-
L8	0.37	5.0	4.6	8	1.6	46,000	8.00	\$368,000
L9	0.19	5.0	3.2	4	3.3	14,000	-	-
L10	0.04	5.0	1.6	4	0.8	22,000	-	-
L11	0.02	5.0	1.1	4	0.4	22,000	-	-
L12	0.02	5.0	1.1	4	0.4	16,000	-	-
L13	0.14	5.0	2.8	4	2.5	15,000	-	-
L14	0.10	5.0	2.4	4	1.8	4,000	-	-
L15	0.03	5.0	1.2	4	0.5	17,000	-	-
L16	0.08	5.0	2.1	4	1.4	8,000	-	-
L17	0.02	5.0	1.1	4	0.4	22,000	-	-
L18	-	-	-	-	-	14,000	-	-
L19	0.31	5.0	4.2	6	2.5	8,000	4.50	\$36,000
L20	0.03	5.0	1.4	4	0.6	2,600	-	-
L21	0.35	5.0	4.4	6	2.7	4,600	4.50	\$20,700
L22	0.62	5.0	5.9	6	4.9	9,400	4.50	\$42,300
L23	0.64	5.0	6.0	6	5.0	7,000	4.50	\$31,500
L23A	0.67	5.0	6.2	8	3.0	800	8.00	\$6,400
L24	0.02	5.0	1.1	4	0.4	13,000	-	-
L25	0.06	5.0	1.8	4	1.1	22,000	-	-
L26	0.01	5.0	0.9	4	0.2	8,000	-	-
L27	0.05	5.0	1.6	4	0.8	50,000	-	-
L28	0.22	5.0	3.5	4	3.9	10,000	-	-
L29	0.02	5.0	1.1	4	0.4	11,000	-	-
L30	0.20	5.0	3.4	4	3.6	12,000	-	-
L31	0.03	5.0	1.4	4	0.6	16,000	-	-
L32	0.17	5.0	3.1	4	3.0	14,000	-	-
L32A	0.17	5.0	3.1	6	1.3	18,000	4.50	\$81,000
L33	0.31	5.0	4.2	6	2.5	6,000	4.50	\$27,000
L34	0.53	5.0	5.5	6	4.2	10,000	4.50	\$45,000
L35	0.11	5.0	2.5	4	2.0	4,000	-	-
L36	1.15	5.0	8.1	10	3.3	10,000	10.00	\$100,000
L37	1.93	5.0	10.5	12	3.8	8,000	12.00	\$96,000
L38	1.99	5.0	10.6	12	3.9	13,000	12.00	\$156,000
L39	2.31	5.0	11.4	12	4.6	5,300	12.00	\$63,600
L40	0.32	5.0	4.3	6	2.6	26,500	4.50	\$119,250
L41	0.15	5.0	2.9	6	1.2	31,500	4.50	\$141,750
L42	0.14	5.0	2.8	4	2.4	16,000	-	-
L43	1.10	5.0	7.9	10	3.1	42,000	10.00	\$420,000
L44	0.14	5.0	2.8	6	1.1	32,000	4.50	\$144,000
L45	0.44	5.0	5.0	8	2.0	18,000	8.00	\$144,000
L46	-	-	-	-	-	142,000	-	-
L47	-	-	-	-	-	50,000	-	-
<b>Total Estimated Major Line Cost</b>								<b>\$2,042,500</b>

**Table 7-27**  
**Estimated Treatment Plant Costs**  
**Purchase Water From GBRA With GBRA Treatment a/**

Function	Total Cost						
	1990	1995	2000	2005	2010	2015	2020
1. Construction Cost							
a. Pumping Facilities	\$0	\$30,418	\$37,008	-	\$64,778	-	-
b. Treatment Works	\$2,500,000	\$1,824,979	\$2,220,388	-	\$3,288,885	-	-
c. Transmission Mains	\$0	\$0	\$0	-	\$0	-	-
2. Engineering b/	\$125,000	\$92,770	\$112,869	-	\$187,073	-	-
3. Land c/	\$100,000	\$0	\$0	-	\$0	-	-
4. Surveying and Staking d/	\$150,000	\$111,324	\$135,442	-	\$200,488	-	-
5. Legal and Administration e/	\$62,500	\$48,385	\$58,434	-	\$83,537	-	-
6. Permitting and Fees f/	\$50,000	\$37,108	\$45,147	-	\$66,829	-	-
7. Contingencies g/	\$250,000	\$185,540	\$225,737	-	\$334,146	-	-
<b>Total</b>	<b>\$3,237,500</b>	<b>\$2,328,522</b>	<b>\$2,833,003</b>	<b>-</b>	<b>\$4,193,536</b>	<b>-</b>	<b>-</b>

- a/ All costs assumes 1990 dollars inflated a 4% per year..
- b/ Assumes 5% of total construction cost.
- c/ Based on current estimated cost of \$5,000/acre.
- d/ Based on 3% of construction cost.
- e/ Based on 2.5% of construction cost.
- f/ Based on 2% of construction cost.
- g/ Based on 10% of construction costs.

**Table 7-28**  
**Estimated Transmission Line Costs**  
**Purchase Water From GBRA With GBRA Treatment a/**

Function	Total Cost						
	1990	1995	2000	2005	2010	2015	2020
1. Construction Cost							
a. Pumping Facilities	\$0	-	-	\$0	-	-	-
b. Treatment Works	\$0	-	-	\$0	-	-	-
c. Transmission Mains	\$3,539,000	-	-	\$3,678,427	-	-	-
2. Engineering b/	\$178,950	-	-	\$183,921	-	-	-
3. Land c/	\$0	-	-	\$0	-	-	-
4. Surveying and Staking d/	\$212,340	-	-	\$220,706	-	-	-
5. Legal and Administration e/	\$88,475	-	-	\$91,961	-	-	-
6. Permitting and Fees f/	\$70,780	-	-	\$73,589	-	-	-
7. Contingencies g/	\$353,900	-	-	\$367,843	-	-	-
<b>Total</b>	<b>\$4,441,445</b>	<b>-</b>	<b>-</b>	<b>\$4,616,428</b>	<b>-</b>	<b>-</b>	<b>-</b>

- a/ All costs assumes 1990 dollars inflated a 4% per year..
- b/ Assumes 5% of total construction cost.
- c/ Based on current estimated cost of \$5,000/acre.
- d/ Based on 3% of construction cost.
- e/ Based on 2.5% of construction cost.
- f/ Based on 2% of construction cost.
- g/ Based on 10% of construction costs.

Table 7-29  
Cost Analysis of GBRA Treatment With CRWA Distribution Option  
(No Take-or-Pay Restrictions)

Year	Capital Plant a/	O&M Plant b/	Capital Plant c/	O&M Plant b/	Capital Plant d/	O&M Plant b/	Capital Plant e/	O&M Plant b/	Trmnt Cost f/	Capital Plant g/	O&M Plant h/	Capital Plant i/	O&M Plant h/	Line Cost	Demand (MGD)	Purchased (MGD)	Cost of Water j/	Total Cost	Cumulative Cost	Cost/1,000 gal. Treated
1990	287,579	125,000							495,095	394,522	176,950			571,472	1.44	1.44	70,963	1,137,530	1,137,530	2.16
1991	287,579	130,000							501,095	394,522	184,028			578,550	1.88	1.88	92,745	1,172,390	2,309,920	1.71
1992	287,579	135,200							507,335	394,522	191,388			585,911	2.32	2.32	114,527	1,207,773	3,517,692	1.42
1993	287,579	140,608							513,824	394,522	199,045			593,567	2.77	2.77	136,308	1,243,700	4,761,392	1.23
1994	287,579	145,232							520,573	394,522	207,006			601,528	3.21	3.21	158,090	1,280,192	6,041,584	1.09
1995	287,579	152,082	206,837	92,770					887,120	394,522	215,287			809,809	3.65	3.65	218,842	1,715,771	7,757,355	1.29
1996	287,579	158,185	206,837	96,481					898,873	394,522	223,898			818,420	3.84	3.84	229,994	1,747,287	9,504,643	1.25
1997	287,579	164,491	206,837	100,340					911,096	394,522	232,854			827,376	4.02	4.02	241,146	1,779,618	11,284,261	1.21
1998	287,579	171,071	206,837	104,354					923,806	394,522	242,168			836,690	4.21	4.21	252,298	1,812,796	13,097,057	1.18
1999	287,579	177,914	206,837	108,528					937,029	394,522	251,855			846,377	4.39	4.39	263,450	1,846,855	14,943,913	1.15
2000	287,579	185,031	206,837	112,869	251,648	112,870			1,388,200	394,522	261,929			856,451	4.58	4.58	274,601	2,319,252	17,263,165	1.39
2001	287,579	192,432	206,837	117,384	251,648	117,385			1,407,917	394,522	272,406			866,929	4.76	4.76	285,274	2,360,119	19,623,284	1.36
2002	287,579	200,129	206,837	122,079	251,648	122,080			1,428,422	394,522	283,303			877,825	4.94	4.94	295,946	2,402,193	22,025,477	1.33
2003	287,579	208,134	206,837	126,962	251,648	126,963			1,449,748	394,522	294,635			888,157	5.11	5.11	306,618	2,445,523	24,471,000	1.31
2004	287,579	216,460	206,837	132,041	251,648	132,042			1,471,927	394,522	306,420			900,942	5.29	5.29	317,291	2,490,160	26,961,160	1.29
2005	287,579	225,118	206,837	137,322	251,648	137,324			1,494,993	394,522	318,677	410,065	183,820	1,307,184	5.47	5.47	485,485	3,287,642	30,248,802	1.65
2006	287,579	234,123	206,837	142,815	251,648	142,817			1,518,982	394,522	331,424	410,065	191,277	1,327,288	5.63	5.63	500,020	3,346,290	33,595,092	1.63
2007	287,579	243,488	206,837	148,328	251,648	148,329			1,543,930	394,522	344,681	410,065	198,928	1,348,196	5.80	5.80	514,575	3,406,701	37,001,794	1.61
2008	287,579	253,227	206,837	154,469	251,648	154,470			1,569,876	394,522	358,468	410,065	206,888	1,369,941	5.96	5.96	529,130	3,468,847	40,470,741	1.59
2009	287,579	263,356	206,837	160,648	251,648	160,649			1,596,860	394,522	372,807	410,065	215,160	1,392,555	6.13	6.13	543,696	3,533,100	44,003,841	1.58
2010	287,579	273,890	206,837	167,074	251,648	167,075	372,501	167,073	2,272,412	394,522	387,719	410,065	223,767	1,416,073	6.29	6.29	568,241	4,246,726	48,250,567	1.85
2011	287,579	284,846	206,837	173,756	251,648	173,758	372,501	173,756	2,308,617	394,522	403,228	410,065	232,717	1,440,539	6.38	6.38	566,406	4,316,558	52,567,122	1.85
2012	287,579	296,240	206,837	180,707	251,648	180,708	372,501	180,706	2,348,311	394,522	419,357	410,065	242,026	1,465,971	6.47	6.47	574,571	4,388,852	56,955,975	1.86
2013	287,579	308,089	206,837	187,935	251,648	187,937	372,501	187,934	2,388,552	394,522	436,131	410,065	251,707	1,492,426	6.57	6.57	582,736	4,463,714	61,419,690	1.86
2014	287,579	320,413	206,837	195,452	251,648	195,454	372,501	195,452	2,430,403	394,522	453,577	410,065	261,776	1,519,940	6.66	6.66	590,901	4,541,244	65,960,933	1.87
2015	287,579	333,230	206,837	203,270	251,648	203,272	372,501	203,270	2,473,928	394,522	471,720	410,065	272,247	1,548,554	6.75	6.75	886,764	4,909,246	70,870,179	1.99
2016	287,579	346,559	206,837	211,401	251,648	211,403	372,501	211,401	2,519,194	394,522	490,589	410,065	283,136	1,578,312	6.89	6.89	918,619	5,016,325	75,886,505	1.97
2017	287,579	360,421	206,837	219,857	251,648	219,860	372,501	219,857	2,568,271	394,522	510,212	410,065	294,482	1,609,281	7.24	7.24	950,874	5,126,406	81,012,911	1.94
2018	287,579	374,838	206,837	228,652	251,648	228,654	372,501	228,651	2,615,231	394,522	530,621	410,065	308,240	1,641,448	7.48	7.48	982,928	5,239,608	86,252,516	1.92
2019	287,579	389,831	206,837	237,798	251,648	237,800	372,501	237,797	2,666,149	394,522	561,845	410,065	318,490	1,674,923	7.73	7.73	1,014,983	5,356,055	91,608,573	1.90
2020		405,425	206,837	247,310	251,648	247,312	372,501	247,309	2,374,008		573,918	410,065	331,230	1,315,214	7.97	7.97	1,047,038	4,735,261	96,344,835	1.63

a/ Based on an initial capital expenditure of \$3,237,500 in 1990 and amortized at 8% APR for 30 years.  
b/ 0.05% of construction cost inflated at 4% per year.  
c/ Based on a capital expenditure of \$1,913,900 (1990 dollars) inflated at 4% per year to 1995 (\$2,328,522) and amortized at 8% APR for 30 years.  
d/ Based on a capital expenditure of \$1,913,900 (1990 dollars) inflated at 4% per year to 2000 (\$2,833,000) and amortized at 8% APR for 30 years.  
e/ Based on a capital expenditure of \$1,913,900 (1990 dollars) inflated at 4% per year to 2010 (\$4,193,500) and amortized at 8% APR for 30 years.  
f/ Assumes a 20% GBRA operations overhead margin.  
g/ Based on an initial capital expenditure of \$4,441,445 in 1990 and amortized at 8% APR for 30 years.  
h/ 0.05% of construction cost inflated at 4% per year.  
i/ Based on a capital expenditure of \$2,583,300 (1990 dollars) inflated at 4% per year to 2005 (\$4,616,426) and amortized at 8% APR for 30 years.  
j/ Based on \$44/AF inflated at 4% per year for amount of water actually used.

Figure 7-8  
Cost/1,000 gal of Water Purchased from GBRA

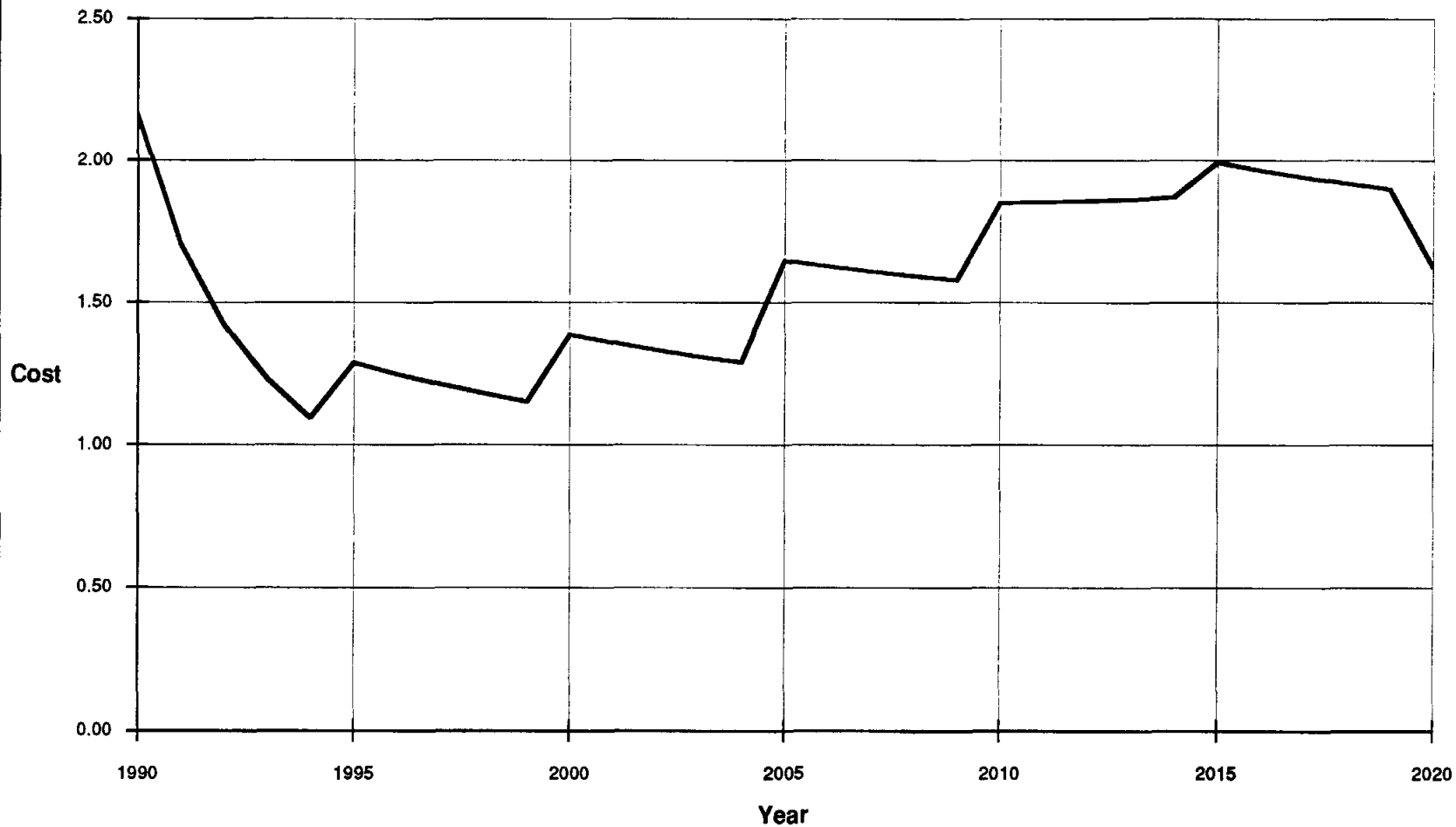

**Figure 7-9**  
**Annual Cost Water Purchased from GBRA**

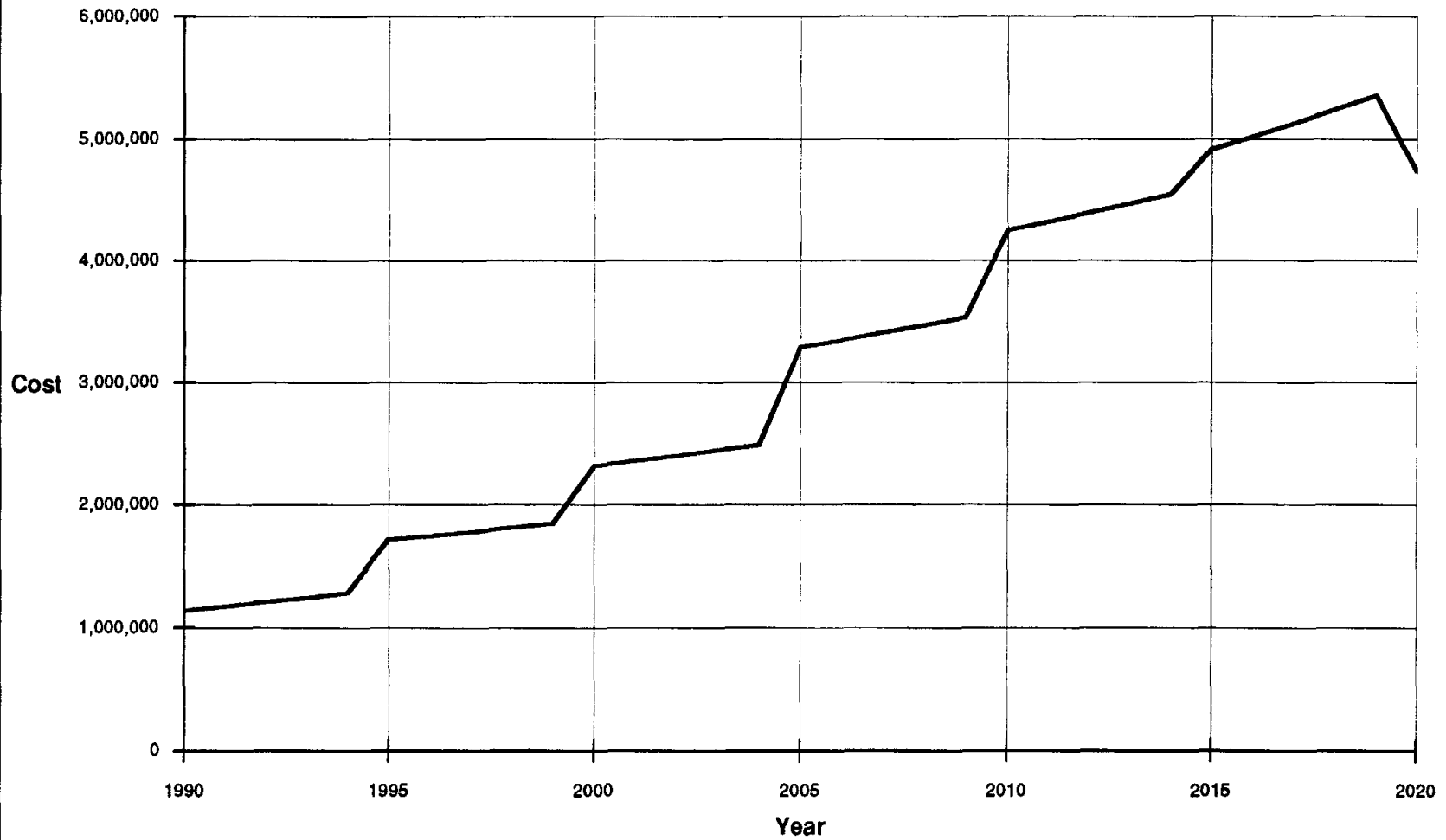

**Figure 7-10**  
**Cumulative Cost of Water Purchased**

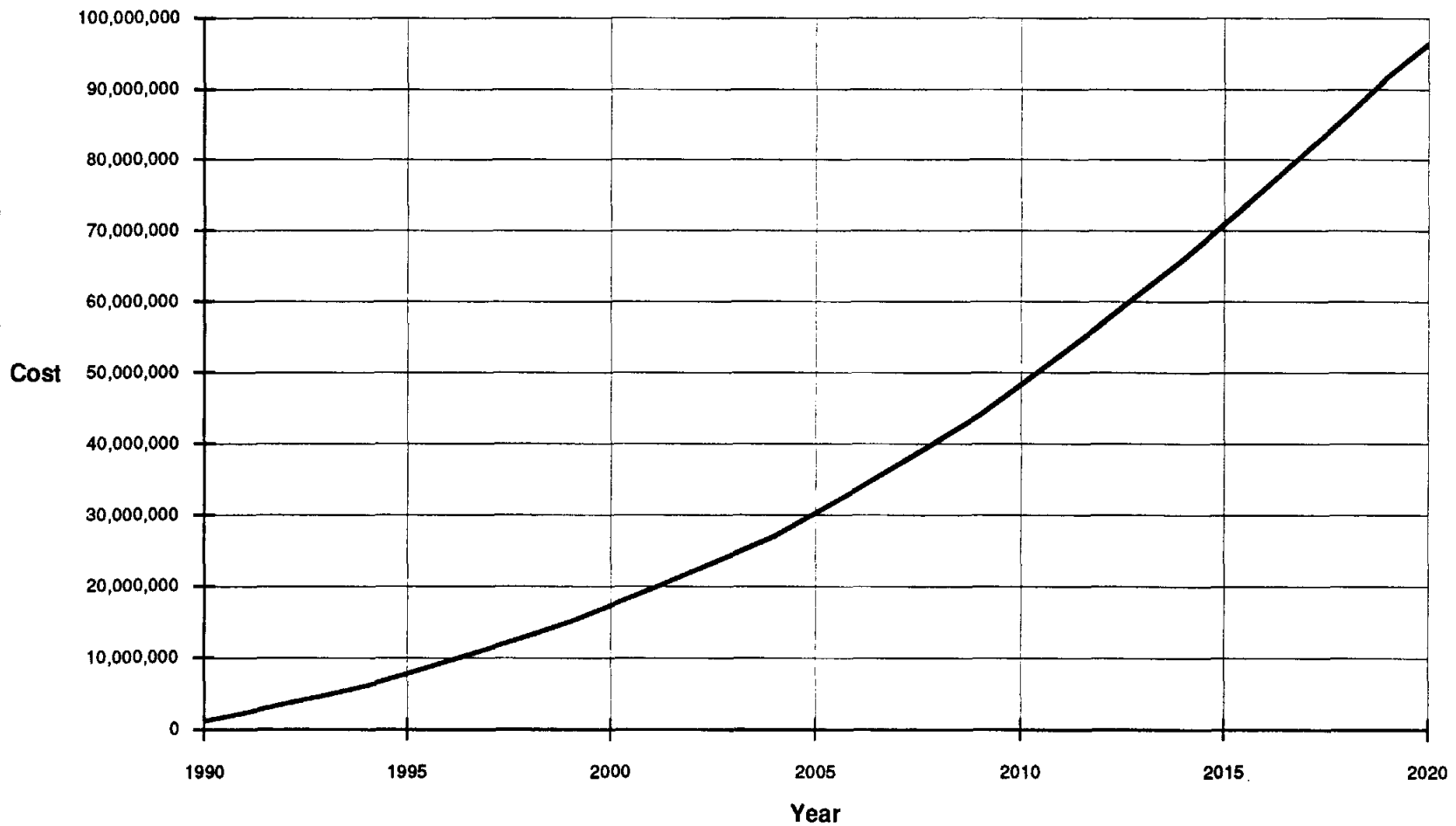

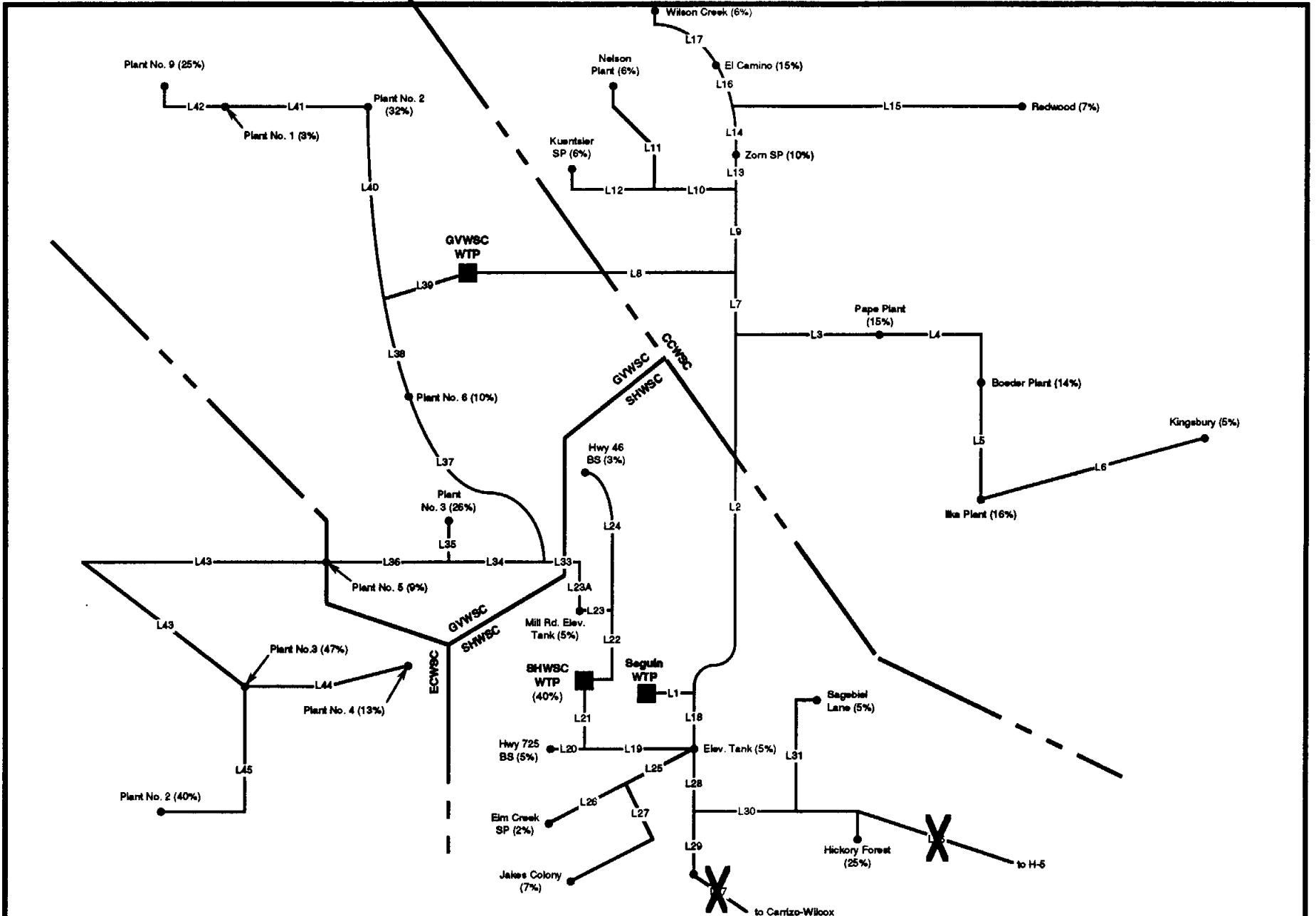

Figure 7-11  
 Development Option Utilizing Excess Capacity of Existing Seguin WTP Through 2005  
 In Conjunction with New CRWA or GBRA Constructed Facilities



Table 7-30  
Phase I Installation of Major Transmission Mains  
Seguin/CRWA Treatment (1990-2005)

Line Designation	Design Flow Rate (MGD)	Design Velocity (FPS)	Calculated Pipe Diameter (In)	Design Pipe Diameter (In)	Actual Velocity (FPS)	Approximate Pipe Length (Ft)	Pipe Unit Cost (\$/Ft)	Estimated Cost of Pipe (\$)
L1	3.65	5.0	14.4	16	4.0	400	16.00	\$6,400
L2	1.44	5.0	9.0	12	2.8	44,000	12.00	\$528,000
L3	0.72	5.0	6.4	8	3.2	8,600	8.00	\$68,800
L4	0.64	5.0	6.0	8	2.8	16,000	8.00	\$128,000
L5	0.38	5.0	4.7	8	1.7	30,000	8.00	\$240,000
L6	0.09	5.0	2.3	4	1.6	32,000	-	-
L7	0.92	5.0	7.2	8	4.1	5,000	8.00	\$40,000
L8	2.20	5.0	11.2	14	3.2	46,000	14.00	\$644,000
L9	0.92	5.0	7.2	8	4.1	14,000	8.00	\$112,000
L10	0.22	5.0	3.5	6	1.7	22,000	4.50	\$99,000
L11	0.11	5.0	2.5	4	1.9	22,000	-	-
L12	0.11	5.0	2.5	4	1.9	16,000	-	-
L13	0.70	5.0	6.3	8	3.1	15,000	8.00	\$120,000
L14	0.51	5.0	5.4	6	4.0	4,000	4.50	\$18,000
L15	0.13	5.0	2.7	4	2.3	17,000	-	-
L16	0.38	5.0	4.7	6	3.0	8,000	4.50	\$36,000
L17	0.11	5.0	2.5	4	1.9	22,000	-	-
L18	2.21	5.0	11.2	12	4.4	14,000	12.00	\$168,000
L19	2.21	5.0	11.2	12	4.4	8,000	12.00	\$96,000
L20	0.02	5.0	1.1	4	0.4	2,500	-	-
L21	2.21	5.0	11.2	12	4.4	4,600	12.00	\$55,200
L22	2.21	5.0	11.2	12	4.4	9,400	12.00	\$112,800
L23	2.21	5.0	11.2	12	4.4	7,000	12.00	\$84,000
L23A	2.21	5.0	11.2	12	4.4	800	12.00	\$9,600
L24	0.01	5.0	0.9	4	0.2	13,000	-	-
L25	0.04	5.0	1.5	4	0.7	22,000	-	-
L26	0.01	5.0	0.7	4	0.2	8,000	-	-
L27	0.03	5.0	1.3	4	0.5	50,000	-	-
L28	0.15	5.0	2.9	4	2.6	10,000	-	-
L29	0.01	5.0	0.9	4	0.2	11,000	-	-
L30	0.12	5.0	2.6	4	2.2	12,000	-	-
L31	0.02	5.0	1.1	4	0.4	16,000	-	-
L32	0.11	5.0	2.5	4	2.0	14,000	-	-
L32A	0.11	5.0	2.5	4	2.0	18,000	-	-
L33	3.20	5.0	13.5	14	4.6	6,000	12.00	\$72,000
L34	1.81	5.0	10.1	12	3.6	10,000	12.00	\$120,000
L35	0.42	5.0	4.9	6	3.3	4,000	4.50	\$18,000
L36	1.39	5.0	8.9	10	3.9	10,000	10.00	\$100,000
L37	0.60	5.0	5.8	6	4.7	8,000	4.50	\$36,000
L38	0.80	5.0	6.7	8	3.5	13,000	8.00	\$104,000
L39	4.84	5.0	16.6	18	4.2	5,300	20.00	\$106,000
L40	1.19	5.0	8.2	10	3.4	26,500	10.00	\$265,000
L41	0.56	5.0	5.6	8	2.5	31,500	8.00	\$252,000
L42	0.50	5.0	5.3	6	3.9	16,000	4.50	\$72,000
L43	1.21	5.0	8.3	12	2.4	42,000	12.00	\$504,000
L44	0.16	5.0	3.0	6	1.2	32,000	4.50	\$144,000
L45	0.48	5.0	5.2	8	2.1	18,000	8.00	\$144,000
L46	-	-	-	-	-	142,000	-	-
L47	-	-	-	-	-	50,000	-	-
<b>Total Estimated Major Line Cost</b>								<b>\$4,502,800</b>

Table 7-31  
Phase II Installation of Major Transmission Mains  
Seguin/CRWA Treatment (2005-2020)

Line Designation	Design Flow Rate (MGD)	Design Velocity (FPS)	Calculated Pipe Diameter (In)	Design Pipe Diameter (In)	Actual Velocity (FPS)	Approximate Pipe Length (Ft)	Pipe Unit Cost (\$/Ft)	Estimated Cost of Pipe (\$)
L1	-	-	-	-	-	400	-	-
L2	-	-	-	-	-	44,000	-	-
L3	0.19	5.0	3.2	4	3.3	8,600	-	-
L4	0.13	5.0	2.7	4	2.3	16,000	-	-
L5	0.08	5.0	2.1	4	1.4	30,000	-	-
L6	0.02	5.0	1.0	4	0.3	32,000	-	-
L7	0.19	5.0	3.2	4	3.3	5,000	-	-
L8	-	-	-	-	-	46,000	-	-
L9	0.19	5.0	3.2	4	3.3	14,000	-	-
L10	0.04	5.0	1.6	4	0.8	22,000	-	-
L11	0.02	5.0	1.1	4	0.4	22,000	-	-
L12	0.02	5.0	1.1	4	0.4	16,000	-	-
L13	0.14	5.0	2.8	4	2.5	15,000	-	-
L14	0.10	5.0	2.4	4	1.8	4,000	-	-
L15	0.03	5.0	1.2	4	0.5	17,000	-	-
L16	0.08	5.0	2.1	4	1.4	8,000	-	-
L17	0.02	5.0	1.1	4	0.4	22,000	-	-
L18	-	-	-	-	-	14,000	-	-
L19	-	-	-	-	-	8,000	-	-
L20	0.03	5.0	1.4	4	0.6	2,600	-	-
L21	-	-	-	-	-	4,600	-	-
L22	-	-	-	-	-	9,400	-	-
L23	-	-	-	-	-	7,000	-	-
L23A	-	-	-	-	-	800	-	-
L24	0.02	5.0	1.1	4	0.4	13,000	-	-
L25	0.06	5.0	1.8	4	1.1	22,000	-	-
L26	0.01	5.0	0.9	4	0.2	8,000	-	-
L27	0.05	5.0	1.6	4	0.8	50,000	-	-
L28	0.22	5.0	3.5	4	3.9	10,000	-	-
L29	0.02	5.0	1.1	4	0.4	11,000	-	-
L30	0.19	5.0	3.3	4	3.3	12,000	-	-
L31	0.03	5.0	1.4	4	0.6	16,000	-	-
L32	0.17	5.0	3.1	4	3.0	14,000	-	-
L32A	0.17	5.0	3.1	6	1.3	18,000	4.50	\$81,000
L33	1.64	5.0	9.6	10	4.7	6,000	10.00	\$60,000
L34	1.26	5.0	8.5	10	3.6	10,000	10.00	\$100,000
L35	0.11	5.0	2.5	4	2.0	4,000	-	-
L36	1.15	5.0	8.1	10	3.3	10,000	10.00	\$100,000
L37	0.16	5.0	3.0	4	2.9	8,000	-	-
L38	0.22	5.0	3.5	4	3.8	13,000	-	-
L39	-	-	-	-	-	5,300	-	-
L40	0.32	5.0	4.3	6	2.6	26,500	4.50	\$119,250
L41	0.15	5.0	2.9	6	1.2	31,500	4.50	\$141,750
L42	0.14	5.0	2.8	4	2.4	16,000	-	-
L43	1.10	5.0	7.9	10	3.1	42,000	10.00	\$420,000
L44	0.14	5.0	2.8	6	1.1	32,000	4.50	\$144,000
L45	0.44	5.0	5.0	6	3.5	18,000	4.50	\$81,000
L46	-	-	-	-	-	142,000	-	-
L47	-	-	-	-	-	50,000	-	-
<b>Total Estimated Major Line Cost</b>								<b>\$1,247,000</b>

Table 7-32  
Estimated Treatment Plant Costs  
Purchase Water From GBRA With Seguin/CRWA Treatment a/

Function	Total Cost						
	1990	1995	2000	2005	2010	2015	2020
1. Construction Cost	-	-	-	-	-	-	-
a. Pumping Facilities	-	\$0	\$37,008	\$45,024	\$54,778	-	-
b. Treatment Works	-	\$3,041,832	\$2,220,368	\$2,701,415	\$3,286,685	-	-
c. Transmission Mains	-	\$0	\$0	\$0	\$0	-	-
2. Engineering b/	-	\$152,082	\$112,869	\$137,322	\$167,073	-	-
3. Land c/	-	\$0	\$0	\$0	\$0	-	-
4. Surveying and Staking d/	-	\$182,498	\$135,442	\$164,788	\$200,488	-	-
5. Legal and Administration e/	-	\$78,041	\$58,434	\$88,661	\$83,537	-	-
6. Permitting and Fees f/	-	\$80,833	\$45,147	\$54,929	\$68,829	-	-
7. Contingencies g/	-	\$304,163	\$225,737	\$274,844	\$334,146	-	-
<b>Total</b>	-	<b>\$3,817,248</b>	<b>\$2,833,003</b>	<b>\$3,446,781</b>	<b>\$4,193,536</b>	-	-

- a/ All costs assumes 1990 dollars inflated a 4% per year.  
b/ Assumes 5% of total construction cost.  
c/ Based on current estimated cost of \$5,000/acre.  
d/ Based on 3% of construction cost.  
e/ Based on 2.5% of construction cost.  
f/ Based on 2% of construction cost.  
g/ Based on 10% of construction costs.

Table 7-33  
Estimated Transmission Line Costs  
Purchase Water From GBRA With Seguin/CRWA Treatment a/

Function	Total Cost						
	1990	1995	2000	2005	2010	2015	2020
1. Construction Cost	-	-	-	-	-	-	-
a. Pumping Facilities	\$0	-	-	\$0	-	-	-
b. Treatment Works	\$0	-	-	\$0	-	-	-
c. Transmission Mains	\$4,502,800	-	-	\$2,245,777	-	-	-
2. Engineering b/	\$225,140	-	-	\$112,289	-	-	-
3. Land c/	\$0	-	-	\$0	-	-	-
4. Surveying and Staking d/	\$270,188	-	-	\$134,747	-	-	-
5. Legal and Administration e/	\$112,570	-	-	\$58,144	-	-	-
6. Permitting and Fees f/	\$90,056	-	-	\$44,918	-	-	-
7. Contingencies g/	\$450,280	-	-	\$224,578	-	-	-
<b>Total</b>	<b>\$5,651,014</b>	-	-	<b>\$2,818,450</b>	-	-	-

- a/ All costs assumes 1990 dollars (4% annual inflation).  
b/ Assumes 5% of total construction cost.  
c/ Based on current estimated cost of \$5,000/acre.  
d/ Based on 3% of construction cost.  
e/ Based on 2.5% of construction cost.  
f/ Based on 2% of construction cost.  
g/ Based on 10% of construction costs.

**Table 7-32**  
**Estimated Treatment Plant Costs**  
**Purchase Water From GBRA With Seguin/CRWA Treatment a/**

Function	Total Cost						
	1990	1995	2000	2005	2010	2015	2020
1. Construction Cost	-	-	-	-	-	-	-
a. Pumping Facilities	-	\$0	\$37,006	\$45,024	\$54,778	-	-
b. Treatment Works	-	\$3,041,632	\$2,220,366	\$2,701,415	\$3,266,685	-	-
c. Transmission Mains	-	\$0	\$0	\$0	\$0	-	-
2. Engineering b/	-	\$152,082	\$112,869	\$137,322	\$167,073	-	-
3. Land c/	-	\$0	\$0	\$0	\$0	-	-
4. Surveying and Staking d/	-	\$182,498	\$135,442	\$164,786	\$200,488	-	-
5. Legal and Administration e/	-	\$76,041	\$58,434	\$68,681	\$83,537	-	-
6. Permitting and Fees f/	-	\$60,833	\$45,147	\$54,929	\$66,829	-	-
7. Contingencies g/	-	\$304,163	\$225,737	\$274,644	\$334,146	-	-
<b>Total</b>	-	<b>\$3,817,248</b>	<b>\$2,833,003</b>	<b>\$3,446,781</b>	<b>\$4,193,536</b>	-	-

a/ All costs assumes 1990 dollars inflated a 4% per year..

b/ Assumes 5% of total construction cost.

c/ Based on current estimated cost of \$5,000/acre.

d/ Based on 3% of construction cost.

e/ Based on 2.5% of construction cost.

f/ Based on 2% of construction cost.

g/ Based on 10% of construction costs.

**Table 7-33**  
**Estimated Transmission Line Costs**  
**Purchase Water From GBRA With Seguin/CRWA Treatment a/**

Function	Total Cost						
	1990	1995	2000	2005	2010	2015	2020
1. Construction Cost	-	-	-	-	-	-	-
a. Pumping Facilities	\$0	-	-	\$0	-	-	-
b. Treatment Works	\$0	-	-	\$0	-	-	-
c. Transmission Mains	\$4,502,800	-	-	\$2,245,777	-	-	-
2. Engineering b/	\$225,140	-	-	\$112,289	-	-	-
3. Land c/	\$0	-	-	\$0	-	-	-
4. Surveying and Staking d/	\$270,168	-	-	\$134,747	-	-	-
5. Legal and Administration e/	\$112,570	-	-	\$58,144	-	-	-
6. Permitting and Fees f/	\$90,056	-	-	\$44,916	-	-	-
7. Contingencies g/	\$450,280	-	-	\$224,578	-	-	-
<b>Total</b>	<b>\$5,651,014</b>	-	-	<b>\$2,818,450</b>	-	-	-

a/ All costs assumes 1990 dollars (4% annual inflation).

b/ Assumes 5% of total construction cost.

c/ Based on current estimated cost of \$5,000/acre.

d/ Based on 3% of construction cost.

e/ Based on 2.5% of construction cost.

f/ Based on 2% of construction cost.

g/ Based on 10% of construction costs.

Table 7-34  
 Cost Analysis of Use of Seguin WTP Excess Capacity in Combination with  
 Construction of CRWA Treatment and Distribution Facilities  
 (2.250 AF/yr Purchase Increment)

Year	Capital Plant a/	O&M Plant b/	Capital Plant c/	O&M Plant b/	Capital Plant d/	O&M Plant b/	Capital Plant e/	O&M Plant b/	Tmnt Cost f/	Capital Line g/	O&M Line h/	Capital Line i/	O&M Line h/	Line Cost	Demand (MGD)	Purchased (MGD)	Cost of Water j/	Total Cost	Cumulative Cost	Cost/1,000 gal. Treated
1990									365,000	501,984	225,140			727,104	1.44	2.00	96,560	1,190,664	1,190,664	2.27
1991									365,000	501,984	234,146			736,109	1.98	2.00	96,560	1,199,669	2,390,333	1.75
1992									365,000	501,984	243,511			745,475	2.32	2.00	96,560	1,209,035	3,599,369	1.43
1993									365,000	501,984	253,252			755,216	2.77	2.00	96,560	1,218,776	4,818,144	1.21
1994									365,000	501,984	263,382			765,346	3.21	2.00	96,560	1,228,906	6,047,050	1.05
1995	339,078	152,080							491,156	501,984	273,917			775,881	3.65	4.00	239,827	1,506,864	7,553,914	1.13
1996	339,078	158,163							497,240	501,984	284,874			786,838	3.84	4.00	239,827	1,523,904	9,077,818	1.09
1997	339,078	164,490							503,568	501,984	296,269			798,233	4.02	4.00	239,827	1,541,625	10,619,443	1.05
1998	339,078	171,069							510,146	501,984	308,120			810,063	4.21	4.00	239,827	1,560,056	12,179,499	1.02
1999	339,078	177,912							516,988	501,984	320,444			822,408	4.39	4.00	239,827	1,579,223	13,758,722	0.98
2000	339,078	185,029	251,648	112,870					888,623	501,984	333,262			835,226	4.58	6.00	359,740	2,083,589	15,842,311	1.25
2001	339,078	192,430	251,648	117,385					900,539	501,984	346,593			848,557	4.76	6.00	359,740	2,108,835	17,951,147	1.21
2002	339,078	200,127	251,648	122,080					912,932	501,984	360,456			862,420	4.94	6.00	359,740	2,135,092	20,086,238	1.19
2003	339,078	208,132	251,648	126,963					925,820	501,984	374,875			876,838	5.11	6.00	359,740	2,162,398	22,248,637	1.16
2004	339,078	216,457	251,648	132,042					939,224	501,984	389,870			891,833	5.29	6.00	359,740	2,190,797	24,439,434	1.13
2005	339,078	225,116	251,648	137,324	306,169	137,320			1,396,652	501,984	405,464	250,356	112,288	1,270,072	5.47	6.00	532,503	3,199,227	27,638,661	1.60
2006	339,078	234,120	251,648	142,817	306,169	142,813			1,416,643	501,984	421,683	250,356	116,780	1,290,782	5.83	6.00	532,503	3,239,926	30,878,589	1.58
2007	339,078	243,485	251,648	148,529	306,169	148,525			1,437,433	501,984	438,550	250,356	121,451	1,312,321	5.80	6.00	532,503	3,282,256	34,160,845	1.55
2008	339,078	253,224	251,648	154,470	306,169	154,466			1,459,054	501,984	456,092	250,356	126,300	1,334,721	5.96	6.00	532,503	3,326,278	37,487,123	1.53
2009	339,078	263,353	251,648	160,649	306,169	160,645			1,481,541	501,984	474,336	250,356	131,361	1,358,017	6.13	6.00	532,503	3,372,060	40,859,183	1.51
2010	339,078	273,887	251,648	167,075	306,169	167,071	372,501	167,000	2,044,428	501,984	493,309	250,356	136,616	1,382,244	6.29	8.00	710,004	4,136,676	44,995,859	1.80
2011	339,078	284,843	251,648	173,758	306,169	173,754	372,501	173,680	2,075,429	501,984	513,042	250,356	142,080	1,407,441	6.38	8.00	710,004	4,192,874	49,188,734	1.80
2012	339,078	296,237	251,648	180,709	306,169	180,704	372,501	180,627	2,107,670	501,984	533,564	250,356	147,763	1,433,646	6.47	8.00	710,004	4,251,321	53,440,054	1.80
2013	339,078	308,086	251,648	187,937	306,169	187,932	372,501	187,852	2,141,201	501,984	554,906	250,356	153,674	1,460,899	6.57	8.00	710,004	4,312,105	57,752,159	1.80
2014	339,078	320,410	251,648	195,454	306,169	195,449	372,501	195,366	2,176,074	501,984	577,102	250,356	159,821	1,489,243	6.66	8.00	710,004	4,373,320	62,127,479	1.80
2015	339,078	333,226	251,648	203,272	306,169	203,267	372,501	203,181	2,212,341	501,984	600,186	250,356	166,214	1,518,720	6.75	8.00	1,050,979	4,782,040	66,906,519	1.94
2016	339,078	346,555	251,648	211,403	306,169	211,398	372,501	211,308	2,250,059	501,984	624,194	250,356	172,862	1,548,376	6.99	8.00	1,050,979	4,850,414	71,759,939	1.90
2017	339,078	360,417	251,648	219,860	306,169	219,854	372,501	219,761	2,289,285	501,984	649,162	250,356	179,777	1,581,258	7.24	8.00	1,050,979	4,921,522	76,681,455	1.86
2018	339,078	374,834	251,648	228,654	306,169	228,648	372,501	228,551	2,330,081	501,984	675,128	250,356	186,968	1,614,415	7.48	8.00	1,050,979	4,995,476	81,676,931	1.83
2019	339,078	389,827	251,648	237,800	306,169	237,794	372,501	237,893	2,372,508	501,984	702,133	250,356	194,446	1,648,899	7.73	8.00	1,050,979	5,072,387	86,749,318	1.80
2020	339,078	405,420	251,648	247,312	306,169	247,306	372,501	247,201	2,418,833		730,219	250,356	202,224	1,682,799	7.97	8.00	1,050,979	4,650,411	91,399,729	1.60

a/ Based on an initial expenditure of \$3,237,500 (1990 dollars) inflated at 4% per year to 1995 (\$3,817,248) and amortized at 8% APR for 30 years.

b/ 0.05% of construction cost inflated at 4% per year.

c/ Based on a capital expenditure of \$1,913,900 (1990 dollars) inflated at 4% per year to 2000 (\$2,833,000) and amortized at 8% APR for 30 years.

d/ Based on a capital expenditure of \$3,827,750 (1990 dollars) inflated at 4% per year to 2010 (\$6,893,562) and amortized at 8% APR for 30 years.

e/ Not required for this option.

f/ Assumes a \$0.50/1,000 treatment charge by the City of Seguin.

g/ Based on an initial capital expenditure of \$5,681,111 in 1990 and amortized at 8% APR for 30 years.

h/ 0.05% of construction cost inflated at 4% per year.

i/ Based on a capital expenditure of \$1,585,000 (1990 dollars) inflated at 4% per year to 2005 (\$2,818,450) and amortized at 8% APR for 30 years.

j/ Based on \$44/AF inflated at 4% per year.

Table 7-35  
 Cost Analysis of Use of Seguin WTP Excess Capacity in Combination with  
 Construction of CRWA Treatment and Distribution Facilities  
 (4,500 AF/yr Purchase Increment)

Year	Capital Plant a/	O&M Plant b/	Capital Plant c/	O&M Plant d/	Capital Plant e/	O&M Plant f/	Capital Plant g/	O&M Plant h/	Treatment Cost i/	Capital Line j/	O&M Line k/	Capital Line l/	O&M Line m/	Line Cost	Demand (MGD)	Purchased (MGD)	Cost of Water y/	Total Cost	Cumulative Cost	Cost/1,000 gal. Treated
1990									365,000	501,964	225,140			727,104	1.44	4.00	197,120	1,289,224	1,289,224	2.45
1991									365,000	501,964	234,146			736,109	1.88	4.00	197,120	1,298,229	2,587,453	1.89
1992									365,000	501,964	243,511			745,475	2.32	4.00	197,120	1,307,595	3,895,049	1.54
1993									365,000	501,964	253,252			755,216	2.77	4.00	197,120	1,317,336	5,212,384	1.30
1994									365,000	501,964	263,382			765,346	3.21	4.00	197,120	1,327,466	6,539,850	1.13
1995	339,076	152,080							491,156	501,964	273,917			775,861	3.65	4.00	239,827	1,506,864	8,046,714	1.13
1996	339,076	158,163							497,240	501,964	284,874			786,838	3.84	4.00	239,827	1,523,904	9,570,618	1.09
1997	339,076	164,490							503,566	501,964	296,269			798,233	4.02	4.00	239,827	1,541,625	11,112,243	1.05
1998	339,076	171,069							510,146	501,964	308,120			810,063	4.21	4.00	239,827	1,560,056	12,672,299	1.02
1999	339,076	177,912							516,988	501,964	320,444			822,408	4.39	4.00	239,827	1,579,223	14,251,522	0.98
2000	339,076	185,029	251,648	112,870					888,623	501,964	333,262			835,226	4.58	8.00	479,653	2,203,502	16,455,025	1.32
2001	339,076	192,430	251,648	117,385					900,539	501,964	346,593			848,557	4.76	8.00	479,653	2,229,749	18,683,773	1.28
2002	339,076	200,127	251,648	122,060					912,932	501,964	360,456			862,420	4.94	8.00	479,653	2,255,005	20,938,778	1.25
2003	339,076	208,132	251,648	126,963					925,820	501,964	374,875			876,838	5.11	8.00	479,653	2,282,312	23,221,090	1.22
2004	339,076	216,457	251,648	132,042					939,224	501,964	389,870			891,833	5.29	8.00	479,653	2,310,710	25,531,800	1.20
2005	339,076	225,116	251,648	137,324	306,169	137,320			1,396,632	501,964	405,464	250,356	112,288	1,270,072	5.47	8.00	710,004	3,376,728	28,906,529	1.69
2006	339,076	234,120	251,648	142,817	306,169	142,813			1,416,643	501,964	421,683	250,356	116,780	1,290,782	5.63	8.00	710,004	3,417,429	32,325,957	1.66
2007	339,076	243,485	251,648	148,523	306,169	148,525			1,437,433	501,964	438,550	250,356	121,451	1,312,321	5.80	8.00	710,004	3,459,757	35,785,714	1.63
2008	339,076	253,224	251,648	154,470	306,169	154,466			1,459,054	501,964	456,092	250,356	126,309	1,334,721	5.96	8.00	710,004	3,503,779	39,289,493	1.61
2009	339,076	263,353	251,648	160,649	306,169	160,645			1,481,541	501,964	474,336	250,356	131,361	1,358,017	6.13	8.00	710,004	3,549,561	42,839,055	1.59
2010	339,076	273,887	251,648	167,075	306,169	167,071	372,501	167,000	2,044,428	501,964	493,309	250,356	136,816	1,382,244	6.29	8.00	710,004	4,136,676	46,975,731	1.80
2011	339,076	284,843	251,648	173,758	306,169	173,754	372,501	173,680	2,075,429	501,964	513,042	250,356	142,080	1,407,441	6.38	8.00	710,004	4,192,674	51,168,605	1.80
2012	339,076	296,237	251,648	180,709	306,169	180,704	372,501	180,627	2,107,670	501,964	533,564	250,356	147,763	1,433,646	6.47	8.00	710,004	4,251,321	55,419,926	1.80
2013	339,076	308,088	251,648	187,937	306,169	187,932	372,501	187,852	2,141,201	501,964	554,906	250,356	153,674	1,460,869	6.57	8.00	710,004	4,312,105	59,732,031	1.80
2014	339,076	320,410	251,648	195,454	306,169	195,449	372,501	195,366	2,176,074	501,964	577,102	250,356	159,821	1,489,243	6.66	8.00	710,004	4,375,320	64,107,351	1.80
2015	339,076	333,226	251,648	203,272	306,169	203,267	372,501	203,181	2,212,341	501,964	600,186	250,356	166,214	1,518,720	6.75	8.00	1,050,979	4,782,040	68,889,391	1.94
2016	339,076	346,555	251,648	211,403	306,169	211,398	372,501	211,308	2,250,059	501,964	624,194	250,356	172,862	1,549,376	6.99	8.00	1,050,979	4,850,414	73,739,804	1.90
2017	339,076	360,417	251,648	219,860	306,169	219,854	372,501	219,761	2,289,285	501,964	649,162	250,356	179,777	1,581,258	7.24	8.00	1,050,979	4,921,522	78,661,327	1.86
2018	339,076	374,834	251,648	228,654	306,169	228,648	372,501	228,551	2,330,081	501,964	675,128	250,356	186,968	1,614,415	7.48	8.00	1,050,979	4,995,476	83,656,802	1.83
2019	339,076	389,827	251,648	237,800	306,169	237,794	372,501	237,693	2,372,508	501,964	702,133	250,356	194,446	1,648,899	7.73	8.00	1,050,979	5,072,387	88,729,189	1.80
2020	339,076	405,420	251,648	247,312	306,169	247,306	372,501	247,201	2,416,633		730,219	250,356	202,224	1,682,799	7.97	8.00	1,050,979	4,650,411	93,379,600	1.60

a/ Based on an initial expenditure of \$3,237,500 (1990 dollars) inflated at 4% per year to 1995 (\$3,817,248) and amortized at 8% APR for 30 years.  
 b/ 0.05% of construction cost inflated at 4% per year.  
 c/ Based on a capital expenditure of \$1,913,900 (1990 dollars) inflated at 4% per year to 2000 (\$2,833,000) and amortized at 8% APR for 30 years.  
 d/ Based on a capital expenditure of \$3,827,750 (1990 dollars) inflated at 4% per year to 2010 (\$6,893,562) and amortized at 8% APR for 30 years.  
 e/ Not required for this option.  
 f/ Assumes a \$0.50/1,000 treatment charge by the City of Seguin.  
 g/ Based on an initial capital expenditure of \$5,651,111 in 1990 and amortized at 8% APR for 30 years.  
 h/ 0.05% of construction cost inflated at 4% per year.  
 i/ Based on a capital expenditure of \$1,565,000 (1990 dollars) inflated at 4% per year to 2005 (\$2,818,450) and amortized at 8% APR for 30 years.  
 j/ Based on \$44/AF inflated at 4% per year.

Table 7-36  
 Cost Analysis of Use of Seguin WTP Excess Capacity in Combination with  
 Construction of CRWA Treatment and Distribution Facilities  
 (\$,000 AF/yr Purchase Increment)

Year	Capital Plant a/	O&M Plant b/	Capital Plant c/	O&M Plant b/	Capital Plant d/	O&M Plant b/	Capital Plant e/	O&M Plant b/	Trmnt Cost f/	Capital Line g/	O&M Line h/	Capital Line i/	O&M Line h/	Line Cost	Demand (MGD)	Purchased (MGD)	Cost of Water j/	Total Cost	Cumulative Cost	Cost/1,000 gal. Treated
1990									365,000	501,964	225,140			727,104	1.44	8.00	394,240	1,486,344	1,486,344	2.83
1991									365,000	501,964	234,146			736,100	1.88	8.00	394,240	1,495,349	2,981,693	2.18
1992									365,000	501,964	243,511			745,475	2.32	8.00	394,240	1,504,715	4,486,409	1.77
1993									365,000	501,964	253,252			755,216	2.77	8.00	394,240	1,514,456	6,000,864	1.50
1994									365,000	501,964	263,382			765,346	3.21	8.00	394,240	1,524,586	7,525,450	1.30
1995	339,078	152,080							491,158	501,964	273,917			775,981	3.65	8.00	479,653	1,746,691	9,272,141	1.31
1996	339,078	158,163							497,240	501,964	284,874			786,838	3.84	8.00	479,653	1,763,731	11,035,871	1.26
1997	339,078	164,490							503,566	501,964	296,269			798,233	4.02	8.00	479,653	1,781,452	12,817,323	1.21
1998	339,078	171,069							510,146	501,964	308,120			810,083	4.21	8.00	479,653	1,799,882	14,617,206	1.17
1999	339,078	177,912							516,988	501,964	320,444			822,408	4.39	8.00	479,653	1,819,050	16,436,255	1.13
2000	339,078	185,029	251,648	112,870					886,623	501,964	333,262			835,226	4.58	8.00	479,653	2,203,502	18,639,758	1.32
2001	339,078	192,430	251,648	117,385					900,539	501,964	346,593			848,557	4.76	8.00	479,653	2,228,749	20,868,506	1.28
2002	339,078	200,127	251,648	122,080					912,932	501,964	360,456			862,420	4.94	8.00	479,653	2,255,005	23,123,512	1.25
2003	339,078	208,132	251,648	126,963					925,820	501,964	374,875			876,838	5.11	8.00	479,653	2,282,312	25,405,823	1.22
2004	339,078	216,457	251,648	132,042					939,224	501,964	389,870			891,833	5.29	8.00	479,653	2,310,710	27,716,533	1.20
2005	339,078	225,116	251,648	137,324	306,169	137,320			1,396,652	501,964	405,464	250,356	112,288	1,270,072	5.47	8.00	710,004	3,376,728	31,093,262	1.66
2006	339,078	234,120	251,648	142,817	306,169	142,813			1,416,643	501,964	421,683	250,356	116,790	1,290,782	5.83	8.00	710,004	3,417,429	34,510,690	1.68
2007	339,078	243,485	251,648	148,529	306,169	148,525			1,437,433	501,964	438,550	250,356	121,481	1,312,321	5.80	8.00	710,004	3,459,757	37,970,448	1.63
2008	339,078	253,224	251,648	154,470	306,169	154,466			1,459,054	501,964	456,092	250,356	126,309	1,334,721	5.96	8.00	710,004	3,503,779	41,474,226	1.61
2009	339,078	263,353	251,648	160,649	306,169	160,645			1,481,541	501,964	474,336	250,356	131,381	1,358,017	6.13	8.00	710,004	3,549,561	45,023,788	1.59
2010	339,078	273,887	251,648	167,075	306,169	167,071	372,501	167,000	2,044,428	501,964	493,309	250,356	136,816	1,382,244	6.29	8.00	710,004	4,136,676	49,160,464	1.80
2011	339,078	284,843	251,648	173,758	306,169	173,754	372,501	173,680	2,075,429	501,964	513,042	250,356	142,080	1,407,441	6.38	8.00	710,004	4,192,874	53,353,338	1.80
2012	339,078	296,237	251,648	180,709	306,169	180,704	372,501	180,627	2,107,870	501,964	533,564	250,356	147,763	1,433,646	6.47	8.00	710,004	4,251,321	57,604,659	1.80
2013	339,078	308,086	251,648	187,937	306,169	187,932	372,501	187,852	2,141,201	501,964	554,906	250,356	153,674	1,460,899	6.57	8.00	710,004	4,312,105	61,916,764	1.80
2014	339,078	320,410	251,648	195,454	306,169	195,449	372,501	195,366	2,176,074	501,964	577,102	250,356	159,821	1,489,243	6.66	8.00	710,004	4,375,320	66,292,084	1.80
2015	339,078	333,226	251,648	203,272	306,169	203,267	372,501	203,181	2,212,341	501,964	600,186	250,356	166,214	1,518,720	6.75	8.00	1,050,979	4,782,040	71,074,124	1.94
2016	339,078	346,555	251,648	211,403	306,169	211,398	372,501	211,306	2,250,059	501,964	624,194	250,356	172,862	1,549,376	6.99	8.00	1,050,979	4,850,414	75,924,537	1.90
2017	339,078	360,417	251,648	219,860	306,169	219,854	372,501	219,781	2,289,285	501,964	649,162	250,356	179,777	1,581,256	7.24	8.00	1,050,979	4,921,522	80,846,060	1.86
2018	339,078	374,834	251,648	228,654	306,169	228,648	372,501	228,551	2,330,081	501,964	675,128	250,356	186,968	1,614,415	7.48	8.00	1,050,979	4,995,476	85,841,536	1.83
2019	339,078	389,827	251,648	237,800	306,169	237,794	372,501	237,693	2,372,508	501,964	702,133	250,356	194,446	1,648,889	7.73	8.00	1,050,979	5,072,387	90,913,923	1.80
2020	339,078	405,420	251,648	247,312	306,169	247,306	372,501	247,201	2,416,633		730,219	250,356	202,224	1,182,799	7.97	8.00	1,050,979	4,650,411	95,564,333	1.60

a/ Based on an initial expenditure of \$3,237,500 (1990 dollars) inflated at 4% per year to 1995 (\$3,817,248) and amortized at 8% APR for 30 years.  
 b/ 0.05% of construction cost inflated at 4% per year.  
 c/ Based on a capital expenditure of \$1,913,900 (1990 dollars) inflated at 4% per year to 2000 (\$2,833,000) and amortized at 8% APR for 30 years.  
 d/ Based on a capital expenditure of \$3,827,750 (1990 dollars) inflated at 4% per year to 2010 (\$6,893,562) and amortized at 8% APR for 30 years.  
 e/ Not required for this option.  
 f/ Assumes a \$0.50/1,000 treatment charge by the City of Seguin.  
 g/ Based on an initial capital expenditure of \$5,651,111 in 1990 and amortized at 8% APR for 30 years.  
 h/ 0.05% of construction cost inflated at 4% per year.  
 i/ Based on a capital expenditure of \$1,565,000 (1990 dollars) inflated at 4% per year to 2005 (\$2,818,450) and amortized at 8% APR for 30 years.  
 j/ Based on \$44/AF inflated at 4% per year.

CANYON REGIONAL WATER SUPPLY STUDY  
DETAILED COST EVALUATION

cost per 1,000 gal, total annual costs and total cumulative costs (all assuming no rate-leveling financing mechanisms in place) for Option 3 are shown in Figures 7-12 through 7-14.

**7.8.4 Option 4 - Develop Well Fields into the Carrizo-Wilcox Formation**

Option 4 assumes that the CRWA develops a well field in the Carrizo-Wilcox Formation south of Seguin. In addition to constructing individual wells, a treatment facility is assumed to be constructed at the well field site to provide mineral removal. Figure 7-15 illustrates schematically the transmission system necessary to provide service throughout the CRWA service area. Lines L1, L8, L39, and L46 are not used in this option. A transmission main, sized to provide service to all WSCs, designated as line L 47, is shown connecting the well field to the southern end of the Springs Hill WSC service area. At the intersection of lines L18, L19, and L25, the flow is split in two directions; the first being toward Crystal Clear along Hwy 123 and the second being toward the remaining three WSCs along Hwy 725. Line L18 is sized to serve Crystal Clear WSC. Line L19 is sized to serve the northwest portion of Springs Hill WSC and all of Green Valley WSC and East Central WSC. Line L23A is sized to serve Green Valley and East central WSC's. Table 7-37 summarizes flows, pipe sizes, and estimated costs for individual sections of the transmission main system for the initial phase of line installation. Estimated transmission main construction costs for Phase I are \$6,340,000. Estimated transmission main construction costs for Phase II are \$2,055,700. Table 7-38 summarizes the second phase of line installation.

Total costs for Option 4 phased installation of treatment and distribution facilities, taken forward at an annual inflation rate of 4% per year to the actual date of expenditure, are shown in Tables 7-39 and 7-40. Total annualized cost for Option 4 installation, is shown in Table 7-41. Total CRWA cost per 1,000 gal, total annual costs and total cumulative costs (all assuming no rate-leveling financing mechanisms in place) for Option 4 are shown in Figures 7-16 through 7-18.

**7.8.5 Option 5 - Appropriate Surface Water Downstream of GBRA Hydropower Dam H-5**

Option 5 assumes that the CRWA constructs a surface water treatment plant at GBRA Hydrodam H-5 (Wood Lake) southwest of Gonzales. Figure 7-19 illustrates schematically the transmission system necessary to provide service throughout the CRWA service area. Line L46 is sized to provide service to the entire CRWA service area. Lines L1, L8, L39, and L 47 are not used in this option. Lines L2 and L18 are sized to serve Crystal Clear WSC. Line L19 is sized to serve the three remaining WSCs. Table 7-42 summarizes flows, pipe sizes, and estimated costs for individual sections of the transmission main system for the initial phase of line installation. Estimated transmission main construction costs for Phase I is \$11,057,600. Estimated transmission main construction costs for Phase II is \$2,380,200. Table 7-43 summarizes the second phase of line installation.



**Figure 7-12**  
**Cost/1,000 gal of Use of Seguin WWTP Excess Capacity in Combination with**  
**Construction of CRWA Treatment Facilities**  
**Assuming 2,250, 4,500 and 9,000 AF/yr Purchase Increments**

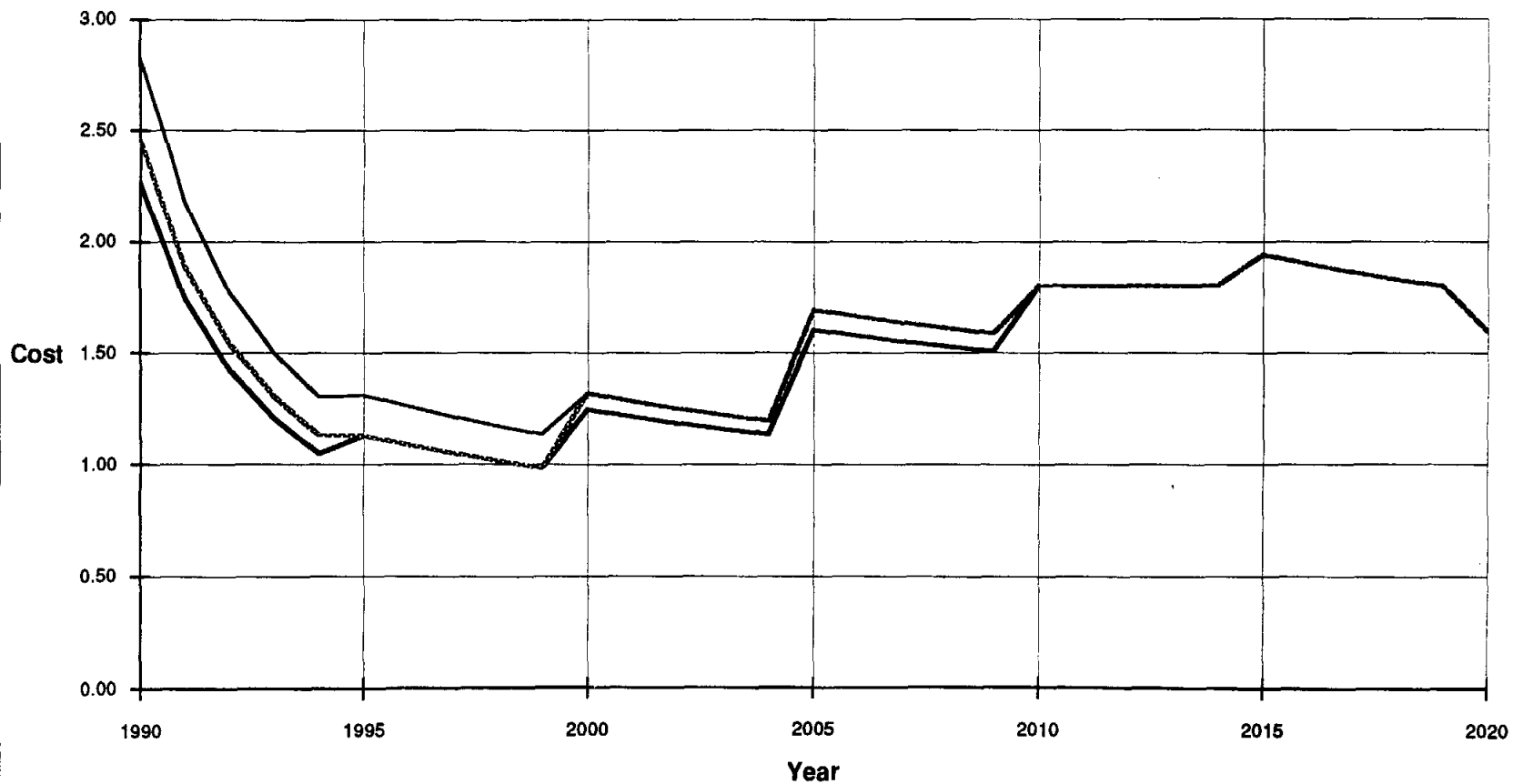

**Figure 7-13**  
**Total Annual Cost of Use of Seguin WWTP Excess Capacity in Combination with**  
**Construction of CRWA Treatment Facilities**  
**Assuming 2,250, 4,500 and 9,000 AF/yr Purchase Increments**

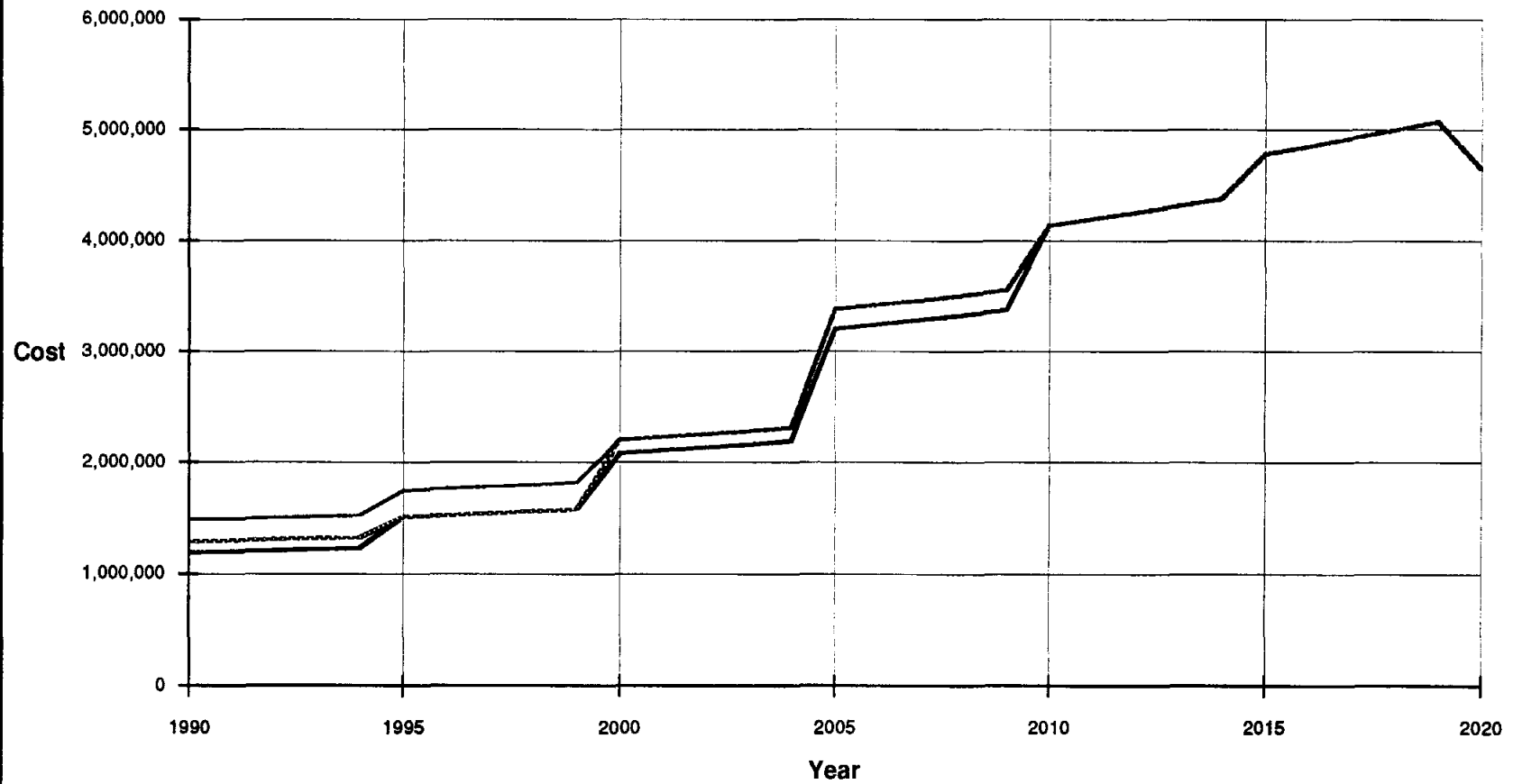

**Figure 7-14**  
**Cumulative Cost of Use of Seguin WWTP Excess Capacity in Combination with**  
**Construction of CRWA Treatment Facilities**  
**Assuming 2,250, 4,500 and 9,000 AF/yr Purchase Increments**

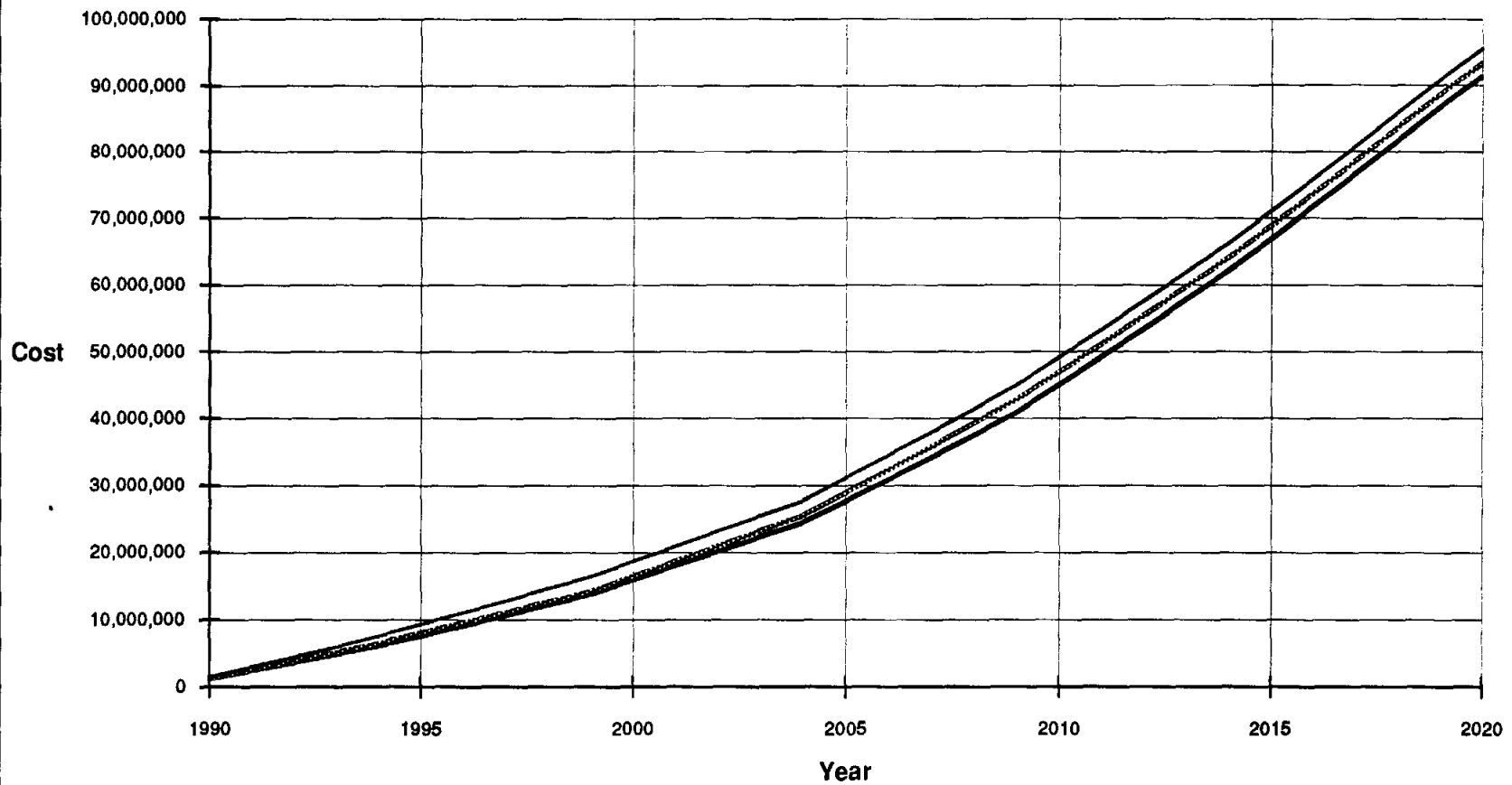

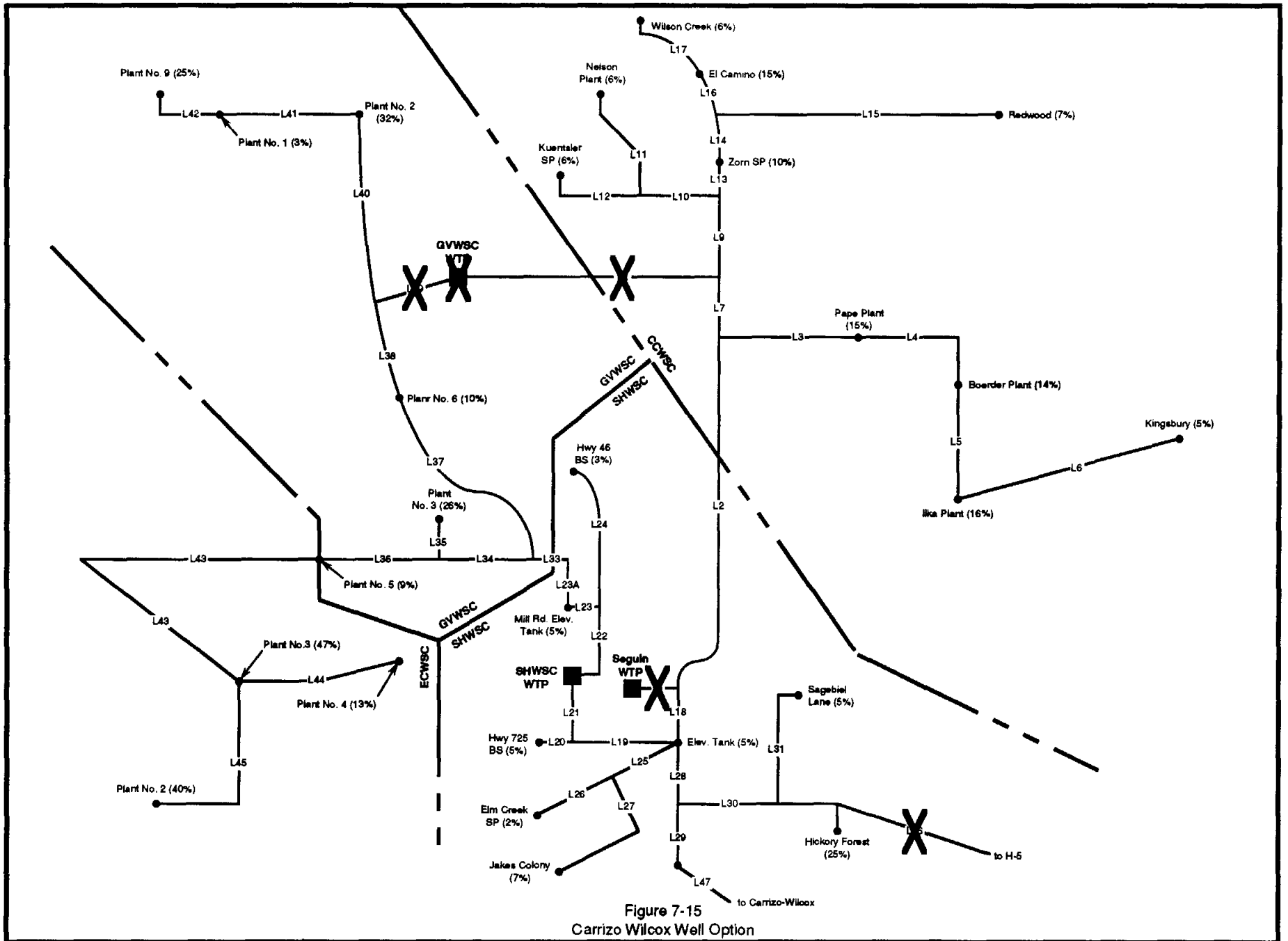

Figure 7-15  
Carrizo Wilcox Well Option

Table 7-37  
Phase I Installation of Major Transmission Mains  
Development of Well Field in Carrizo-Wilcox (1990-2005)

Line Designation	Design Flow Rate (MGD)	Design Velocity (FPS)	Calculated Pipe Diameter (In)	Design Pipe Diameter (In)	Actual Velocity (FPS)	Approximate Pipe Length (Ft)	Pipe Unit Cost (\$/Ft)	Estimated Cost of Pipe (\$)
L1	-	-	-	-	-	400	-	-
L2	1.83	5.0	10.2	12	3.6	44,000	12.00	\$528,000
L3	0.92	5.0	7.2	8	4.1	8,600	8.00	\$68,800
L4	0.64	5.0	6.0	8	2.8	16,000	8.00	\$128,000
L5	0.38	5.0	4.7	8	1.7	30,000	8.00	\$240,000
L6	0.09	5.0	2.3	6	0.7	32,000	4.50	\$144,000
L7	0.92	5.0	7.2	8	4.1	5,000	8.00	\$40,000
L8	-	-	-	-	-	46,000	-	-
L9	0.92	5.0	7.2	8	4.1	14,000	8.00	\$112,000
L10	0.22	5.0	3.5	6	1.7	22,000	4.50	\$99,000
L11	0.11	5.0	2.5	4	1.9	22,000	-	-
L12	0.11	5.0	2.5	4	1.9	16,000	-	-
L13	0.70	5.0	6.3	8	3.1	15,000	8.00	\$120,000
L14	0.51	5.0	5.4	6	4.0	4,000	4.50	\$18,000
L15	0.13	5.0	2.7	4	2.3	17,000	-	-
L16	0.38	5.0	4.7	6	3.0	8,000	4.50	\$36,000
L17	0.11	5.0	2.5	4	1.9	22,000	-	-
L18	1.83	5.0	10.2	10	5.2	14,000	10.00	\$140,000
L19	3.43	5.0	14.0	16	3.8	8,000	16.00	\$128,000
L20	0.02	5.0	1.1	4	0.4	2,600	-	-
L21	3.41	5.0	13.9	14	4.9	4,600	14.00	\$64,400
L22	3.24	5.0	13.5	14	4.7	9,400	14.00	\$131,600
L23	3.22	5.0	13.5	14	4.7	7,000	14.00	\$98,000
L23A	3.20	5.0	13.5	14	4.6	800	14.00	\$11,200
L24	0.01	5.0	0.9	4	0.2	13,000	-	-
L25	0.04	5.0	1.5	4	0.7	22,000	-	-
L26	0.01	5.0	0.7	4	0.2	8,000	-	-
L27	0.03	5.0	1.3	4	0.5	50,000	-	-
L28	5.34	5.0	17.4	18	4.7	10,000	20.00	\$200,000
L29	5.46	5.0	17.6	18	4.8	11,000	20.00	\$220,000
L30	0.12	5.0	2.6	4	2.2	12,000	-	-
L31	0.02	5.0	1.1	4	0.4	16,000	-	-
L32	0.11	5.0	2.5	4	2.0	14,000	-	-
L32A	0.11	5.0	2.5	4	2.0	18,000	-	-
L33	3.20	5.0	13.5	14	4.6	6,000	14.00	\$84,000
L34	1.81	5.0	10.1	12	3.6	10,000	12.00	\$120,000
L35	0.42	5.0	4.9	6	3.3	4,000	4.50	\$18,000
L36	1.39	5.0	8.9	10	3.9	10,000	10.00	\$100,000
L37	1.39	5.0	8.9	10	4.0	8,000	10.00	\$80,000
L38	1.19	5.0	8.2	10	3.4	13,000	10.00	\$130,000
L39	-	-	-	-	-	5,300	-	-
L40	1.19	5.0	8.2	10	3.4	26,500	10.00	\$265,000
L41	0.56	5.0	5.6	8	2.5	31,500	8.00	\$252,000
L42	0.50	5.0	5.3	6	3.9	16,000	4.50	\$72,000
L43	1.21	5.0	8.3	12	2.4	42,000	12.00	\$504,000
L44	0.16	5.0	3.0	6	1.2	32,000	4.50	\$144,000
L45	0.48	5.0	5.2	8	2.1	18,000	8.00	\$144,000
L46	-	-	-	-	-	142,000	-	-
L47	8.15	5.0	21.5	24	4.0	50,000	38.00	\$1,900,000
<b>Total Estimated Major Line Cost</b>								<b>\$6,340,000</b>

Table 7-38  
Phase II Installation of Major Transmission Mains  
Development of Well Field in Carrizo-Wilcox (2005-2020)

Line Designation	Design Flow Rate (MGD)	Design Velocity (FPS)	Calculated Pipe Diameter (In)	Design Pipe Diameter (In)	Actual Velocity (FPS)	Approximate Pipe Length (Ft)	Pipe Unit Cost (\$/Ft)	Estimated Cost of Pipe (\$)
L1	-	-	-	-	-	400	-	-
L2	0.37	5.0	4.6	6	2.9	44,000	4.50	\$198,000
L3	0.19	5.0	3.2	4	3.3	8,600	-	-
L4	0.13	5.0	2.7	4	2.3	16,000	-	-
L5	0.08	5.0	2.1	4	1.4	30,000	-	-
L6	0.02	5.0	1.0	4	0.3	32,000	-	-
L7	0.19	5.0	3.2	4	3.3	5,000	-	-
L8	-	-	-	-	-	46,000	-	-
L9	0.19	5.0	3.2	4	3.3	14,000	-	-
L10	0.04	5.0	1.6	4	0.8	22,000	-	-
L11	0.02	5.0	1.1	4	0.4	22,000	-	-
L12	0.02	5.0	1.1	4	0.4	16,000	-	-
L13	0.14	5.0	2.8	4	2.5	15,000	-	-
L14	0.10	5.0	2.4	4	1.8	4,000	-	-
L15	0.03	5.0	1.2	4	0.5	17,000	-	-
L16	0.08	5.0	2.1	4	1.4	8,000	-	-
L17	0.02	5.0	1.1	4	0.4	22,000	-	-
L18	0.37	5.0	4.6	4	6.6	14,000	-	-
L19	2.00	5.0	10.6	12	3.9	8,000	12.00	\$96,000
L20	0.03	5.0	1.4	4	0.6	2,600	-	-
L21	1.96	5.0	10.5	12	3.9	4,600	12.00	\$55,200
L22	1.69	5.0	9.8	10	4.8	9,400	10.00	\$94,000
L23	1.67	5.0	9.7	10	4.7	7,000	10.00	\$70,000
L23A	1.64	5.0	9.6	10	4.7	800	10.00	\$8,000
L24	0.02	5.0	1.1	4	0.4	13,000	-	-
L25	0.06	5.0	1.8	4	1.1	22,000	-	-
L26	0.01	5.0	0.9	4	0.2	8,000	-	-
L27	0.05	5.0	1.6	4	0.8	50,000	-	-
L28	2.48	5.0	11.9	12	4.9	10,000	12.00	\$120,000
L29	2.66	5.0	12.3	14	3.8	11,000	14.00	\$154,000
L30	0.19	5.0	3.3	4	3.3	12,000	-	-
L31	0.03	5.0	1.4	4	0.6	16,000	-	-
L32	0.17	5.0	3.1	4	3.0	14,000	-	-
L32A	0.17	5.0	3.1	4	3.0	18,000	-	-
L33	1.64	5.0	9.6	10	4.7	6,000	10.00	\$60,000
L34	1.26	5.0	8.5	10	3.6	10,000	10.00	\$100,000
L35	0.11	5.0	2.5	4	2.0	4,000	-	-
L36	1.15	5.0	8.1	10	3.3	10,000	10.00	\$100,000
L37	0.38	5.0	4.6	6	3.0	8,000	4.50	\$36,000
L38	0.32	5.0	4.3	6	2.6	13,000	4.50	\$58,500
L39	-	-	-	-	-	5,300	-	-
L40	0.32	5.0	4.3	6	2.6	26,500	4.50	\$119,250
L41	0.15	5.0	2.9	6	1.2	31,500	4.50	\$141,750
L42	0.14	5.0	2.8	4	2.4	16,000	-	-
L43	1.10	5.0	7.9	10	3.1	42,000	10.00	\$420,000
L44	0.14	5.0	2.8	6	1.1	32,000	4.50	\$144,000
L45	0.44	5.0	5.0	6	3.5	18,000	4.50	\$81,000
L46	-	-	-	-	-	142,000	-	-
L47	-	-	-	-	-	50,000	-	-
<b>Total Estimated Major Line Cost</b>								<b>\$2,055,700</b>

Table 7-39  
Estimated Treatment Plant Costs  
Well Development in the Carrizo-Wilcox Aquifer a/

Function	Total Cost						
	1990	1995	2000	2005	2010	2015	2020
1. Construction Cost							
a. Pumping Facilities	\$175,000	\$30,416	\$37,006	-	\$54,778	-	-
b. Treatment Works	\$2,500,000	\$1,824,979	\$2,220,366	-	\$3,286,685	-	-
c. Transmission Mains	\$0	\$0	\$0	-	\$0	-	-
2. Engineering (b/)	\$133,750	\$92,770	\$112,869	-	\$167,073	-	-
3. Land (c/)	\$0	\$0	\$0	-	\$0	-	-
4. Surveying and Staking (d/)	\$160,500	\$111,324	\$135,442	-	\$200,488	-	-
5. Legal and Administration (e/)	\$66,875	\$46,385	\$56,434	-	\$83,537	-	-
6. Permitting and Fees (f/)	\$53,500	\$37,108	\$45,147	-	\$66,829	-	-
7. Contingencies (g/)	\$267,500	\$185,540	\$225,737	-	\$334,146	-	-
<b>Total</b>	<b>\$3,357,125</b>	<b>\$2,328,522</b>	<b>\$2,833,003</b>	<b>-</b>	<b>\$4,193,536</b>	<b>-</b>	<b>-</b>

a/ All costs assumes 1990 dollars inflated a 4% per year..

b/ Assumes 5% of total construction cost.

c/ Based on current estimated cost of \$5,000/acre.

d/ Based on 3% of construction cost.

e/ Based on 2.5% of construction cost.

f/ Based on 2% of construction cost.

g/ Based on 10% of construction costs.

Table 7-40  
Estimated Transmission Line Costs  
Well Development in the Carrizo-Wilcox Aquifer a/

Function	Total Cost						
	1990	1995	2000	2005	2010	2015	2020
1. Construction Cost							
a. Pumping Facilities	\$0	-	-	\$0	-	-	-
b. Treatment Works	\$0	-	-	\$0	-	-	-
c. Transmission Mains	\$6,340,000	-	-	\$3,702,200	-	-	-
2. Engineering (b/)	\$317,000	-	-	\$185,110	-	-	-
3. Land (c/)	\$0	-	-	\$0	-	-	-
4. Surveying and Staking (d/)	\$380,400	-	-	\$222,132	-	-	-
5. Legal and Administration (e/)	\$158,500	-	-	\$92,555	-	-	-
6. Permitting and Fees (f/)	\$126,800	-	-	\$74,044	-	-	-
7. Contingencies (g/)	\$634,000	-	-	\$370,220	-	-	-
<b>Total</b>	<b>\$7,956,700</b>	<b>-</b>	<b>-</b>	<b>\$4,646,260</b>	<b>-</b>	<b>-</b>	<b>-</b>

a/ All costs assumes 1990 dollars inflated a 4% per year..

b/ Assumes 5% of total construction cost.

c/ Based on current estimated cost of \$5,000/acre.

d/ Based on 3% of construction cost.

e/ Based on 2.5% of construction cost.

f/ Based on 2% of construction cost.

g/ Based on 10% of construction costs.

Table 7-41  
Cost Analysis of Carrizo-Wilcox Supply Option

Year	Capital Well a/	O&M Well b/	Capital Well c/	O&M Well b/	Capital Well d/	O&M Well b/	Capital Well e/	O&M Well b/	Capital Well e/	O&M Well b/	Well Cost	Capital Treatment f/	O&M Treatment	Capital Treatment g/	O&M Treatment	Capital Treatment h/	O&M Treatment	Capital Treatment i/	O&M Treatment	Total Treatment	
1990	61,835	22,500									84,335	298,205	125,000								423,205
1991	61,835	23,400									85,235	298,205	130,000								428,205
1992	61,835	24,336									86,171	298,205	135,200								433,405
1993	61,835	25,306									87,144	298,205	140,608								438,813
1994	61,835	26,322									88,157	298,205	146,232								444,437
1995	61,835	27,375	44,080	19,770							153,060	298,205	152,082	206,837	91,250						748,373
1996	61,835	28,470	44,080	20,561							154,945	298,205	158,165	206,837	94,900						758,106
1997	61,835	29,606	44,080	21,383							156,907	298,205	164,491	206,837	98,696						768,229
1998	61,835	30,793	44,080	22,239							158,946	298,205	171,071	206,837	102,844						778,756
1999	61,835	32,025	44,080	23,128							161,068	298,205	177,914	206,837	106,750						789,705
2000	61,835	33,305	44,080	24,053	28,878	12,952					205,103	298,205	188,031	206,837	111,020	256,089	111,000				1,168,181
2001	61,835	34,638	44,080	25,015	28,878	13,470					207,916	298,205	192,432	206,837	115,480	256,089	115,440				1,184,463
2002	61,835	36,023	44,080	26,016	28,878	14,009					210,841	298,205	200,129	206,837	120,079	256,089	120,058				1,201,396
2003	61,835	37,464	44,080	27,057	28,878	14,569					213,883	298,205	208,134	206,837	124,882	256,089	124,860				1,219,007
2004	61,835	38,963	44,080	28,139	28,878	15,152					217,046	298,205	216,460	206,837	129,877	256,089	129,854				1,237,322
2005	61,835	40,521	44,080	29,264	28,878	15,758					220,336	298,205	225,118	206,837	135,072	256,089	135,048				1,256,370
2006	61,835	42,142	44,080	30,435	28,878	16,388					223,758	298,205	234,123	206,837	140,475	256,089	140,450				1,276,179
2007	61,835	43,828	44,080	31,652	28,878	17,044					227,317	298,205	243,488	206,837	146,084	256,089	146,068				1,296,781
2008	61,835	45,581	44,080	32,919	28,878	17,726					231,018	298,205	253,227	206,837	151,938	256,089	151,911				1,318,207
2009	61,835	47,404	44,080	34,235	28,878	18,435					234,867	298,205	263,356	206,837	158,015	256,089	157,988				1,340,490
2010	61,835	49,300	44,080	35,605	28,878	19,172	42,746	19,172			300,788	298,205	273,890	206,837	164,338	256,089	164,307	372,498	164,000		1,900,182
2011	61,835	51,272	44,080	37,029	28,878	19,939	42,746	19,939			305,718	298,205	284,846	206,837	170,910	256,089	170,879	372,498	170,560		1,930,824
2012	61,835	53,323	44,080	38,510	28,878	20,737	42,746	20,736			310,845	298,205	296,240	206,837	177,746	256,089	177,715	372,498	177,382		1,962,712
2013	61,835	55,456	44,080	40,050	28,878	21,566	42,746	21,566			316,177	298,205	308,069	206,837	184,856	256,089	184,823	372,498	184,478		1,995,875
2014	61,835	57,674	44,080	41,652	28,878	22,429	42,746	22,429			321,723	298,205	320,413	206,837	192,250	256,089	192,216	372,498	191,857		2,030,365
2015	61,835	59,981	44,080	43,319	28,878	23,326	42,746	23,326			327,490	298,205	333,230	206,837	199,940	256,089	199,905	372,498	199,531		2,066,234
2016	61,835	62,381	44,080	45,051	28,878	24,259	42,746	24,259			333,488	298,205	346,559	206,837	207,938	256,089	207,901	372,498	207,512		2,103,538
2017	61,835	64,876	44,080	46,853	28,878	25,229	42,746	25,229			339,726	298,205	360,421	206,837	216,255	256,089	216,217	372,498	215,813		2,142,335
2018	61,835	67,471	44,080	48,727	28,878	26,238	42,746	26,238			346,214	298,205	374,838	206,837	224,905	256,089	224,866	372,498	224,445		2,182,683
2019	61,835	70,170	44,080	50,677	28,878	27,288	42,746	27,288			352,961	298,205	389,831	206,837	233,902	256,089	233,860	372,498	233,423		2,224,845
2020		72,976	44,080	52,704	28,878	28,379	42,746	28,379	63,275	28,400	389,817		405,425	206,837	243,258	256,089	243,215	372,498	242,760		1,970,081

a/ Based on an initial capital expenditure of \$884,375 in 1990 and amortized at 8% APR for 30 years.  
b/ 0.05% of construction cost inflated at 4% per year.  
c/ Based on a capital expenditure of \$219,625 (1990 dollars) inflated at 4% per year to 1995 (\$267,207) and amortized at 8% APR for 30 years.  
d/ Based on a capital expenditure of \$219,625 (1990 dollars) inflated at 4% per year to 2005 (\$395,532) and amortized at 8% APR for 30 years.  
e/ Based on a capital expenditure of \$219,625 (1990 dollars) inflated at 4% per year to 2015 (\$585,484) and amortized at 8% APR for 30 years.  
f/ Based on an initial capital expenditure of \$3,357,125 in 1990 and amortized at 8% APR for 30 years.  
g/ Based on a capital expenditure of \$1,913,900 (1990 dollars) inflated at 4% per year to 1995 (\$2,328,522) and amortized at 8% APR for 30 years.  
h/ Based on a capital expenditure of \$1,913,900 (1990 dollars) inflated at 4% per year to 2000 (\$2,833,000) and amortized at 8% APR for 30 years.  
i/ Based on a capital expenditure of \$1,913,900 (1990 dollars) inflated at 4% per year to 2010 (\$4,193,500) and amortized at 8% APR for 30 years.  
j/ Based on an initial capital expenditure of \$6,340,000 in 1990 and amortized at 8% APR for 30 years.  
k/ Based on a capital expenditure of \$2,055,700 (1990 dollars) inflated at 4% per year to 2005 (\$3,702,200) and amortized at 8% APR for 30 years.  
l/ Procurement, treatment and distribution.



Table 7-41 (Continued)  
Cost Analysis of Carrizo-Wilecox Supply Option

Year	Capital Line j/	O&M Line b/	Capital Line k/	O&M Line b/	Line Cost	Demand (MGD)	Pumped (MGD)	Cost of Water	Total Cost V	Cumulative Cost	Cost/1,000 gal. Treated
1990	706,773	317,000			1,029,773	1.44	1.44	0	1,531,313	1,531,313	2.91
1991	706,773	329,680			1,036,453	1.88	1.88	0	1,549,893	3,081,206	2.26
1992	706,773	342,867			1,049,640	2.32	2.32	0	1,569,216	4,650,422	1.85
1993	706,773	356,582			1,063,355	2.77	2.77	0	1,589,312	6,239,735	1.57
1994	706,773	370,845			1,077,618	3.21	3.21	0	1,610,212	7,849,947	1.38
1995	706,773	385,679			1,092,452	3.65	3.65	0	1,693,885	9,543,832	1.50
1996	706,773	401,106			1,107,879	3.84	3.84	0	2,020,931	11,564,763	1.44
1997	706,773	417,150			1,123,924	4.02	4.02	0	2,049,059	13,613,822	1.40
1998	706,773	433,836			1,140,610	4.21	4.21	0	2,078,312	15,692,134	1.35
1999	706,773	451,190			1,157,963	4.39	4.39	0	2,108,736	18,100,870	1.31
2000	706,773	469,237			1,176,011	4.58	4.58	0	2,549,295	20,650,165	1.52
2001	706,773	488,007			1,194,780	4.76	4.76	0	2,587,159	23,237,324	1.49
2002	706,773	507,527			1,214,300	4.94	4.94	0	2,626,538	25,863,862	1.46
2003	706,773	527,828			1,234,602	5.11	5.11	0	2,667,491	28,531,353	1.43
2004	706,773	548,941			1,255,715	5.29	5.29	0	2,710,083	31,241,436	1.40
2005	706,773	570,899	412,715	185,110	1,875,498	5.47	5.47	0	3,382,204	34,593,640	1.68
2006	706,773	593,735	412,715	192,514	1,905,738	5.63	5.63	0	3,405,675	37,999,315	1.66
2007	706,773	617,484	412,715	200,215	1,937,188	5.80	5.80	0	3,461,286	41,460,601	1.64
2008	706,773	642,184	412,715	208,224	1,969,896	5.96	5.96	0	3,519,121	44,979,722	1.62
2009	706,773	667,871	412,715	216,553	2,003,912	6.13	6.13	0	3,579,269	48,558,991	1.60
2010	706,773	694,586	412,715	225,215	2,039,289	6.29	6.29	0	4,240,239	52,799,230	1.85
2011	706,773	722,369	412,715	234,223	2,076,061	6.38	6.38	0	4,312,623	57,111,853	1.85
2012	706,773	751,264	412,715	243,592	2,114,345	6.47	6.47	0	4,387,901	61,499,754	1.86
2013	706,773	781,315	412,715	253,336	2,154,139	6.57	6.57	0	4,466,191	65,965,946	1.86
2014	706,773	812,567	412,715	263,469	2,195,525	6.66	6.66	0	4,547,613	70,513,558	1.87
2015	706,773	845,070	412,715	274,008	2,238,567	6.75	6.75	0	4,632,291	75,145,849	1.88
2016	706,773	878,873	412,715	284,968	2,283,330	6.99	6.99	0	4,720,356	79,866,205	1.85
2017	706,773	914,028	412,715	296,367	2,329,884	7.24	7.24	0	4,811,944	84,678,149	1.82
2018	706,773	950,589	412,715	308,222	2,378,299	7.48	7.48	0	4,907,196	89,585,345	1.80
2019	706,773	988,613	412,715	320,551	2,428,652	7.73	7.73	0	5,006,257	94,591,602	1.78
2020		1,028,157	412,715	333,373	1,774,245	7.97	7.97	0	4,134,143	98,725,745	1.42

a/ Based on an initial capital expenditure of \$884,375 in 1990 and amortized at 8% APR for 30 years.

b/ 0.05% of construction cost inflated at 4% per year.

c/ Based on a capital expenditure of \$219,625 (1990 dollars) inflated at 4% per year to 1995 (\$267,207) and amortized at 8% APR for 30 years.

d/ Based on a capital expenditure of \$219,625 (1990 dollars) inflated at 4% per year to 2005 (\$395,532) and amortized at 8% APR for 30 years.

e/ Based on a capital expenditure of \$219,625 (1990 dollars) inflated at 4% per year to 2015 (\$585,484) and amortized at 8% APR for 30 years.

f/ Based on an initial capital expenditure of \$3,357,125 in 1990 and amortized at 8% APR for 30 years.

g/ Based on a capital expenditure of \$1,913,900 (1990 dollars) inflated at 4% per year to 1995 (\$2,328,522) and amortized at 8% APR for 30 years.

h/ Based on a capital expenditure of \$1,913,900 (1990 dollars) inflated at 4% per year to 2000 (\$2,833,000) and amortized at 8% APR for 30 years.

i/ Based on a capital expenditure of \$1,913,900 (1990 dollars) inflated at 4% per year to 2010 (\$4,193,500) and amortized at 8% APR for 30 years.

j/ Based on an initial capital expenditure of \$6,340,000 in 1990 and amortized at 8% APR for 30 years.

k/ Based on a capital expenditure of \$2,055,700 (1990 dollars) inflated at 4% per year to 2005 (\$3,702,200) and amortized at 8% APR for 30 years.

v Procurement, treatment and distribution.

Figure 7-16  
Cost/1,000 gal of Carrizo-Wilcox Water

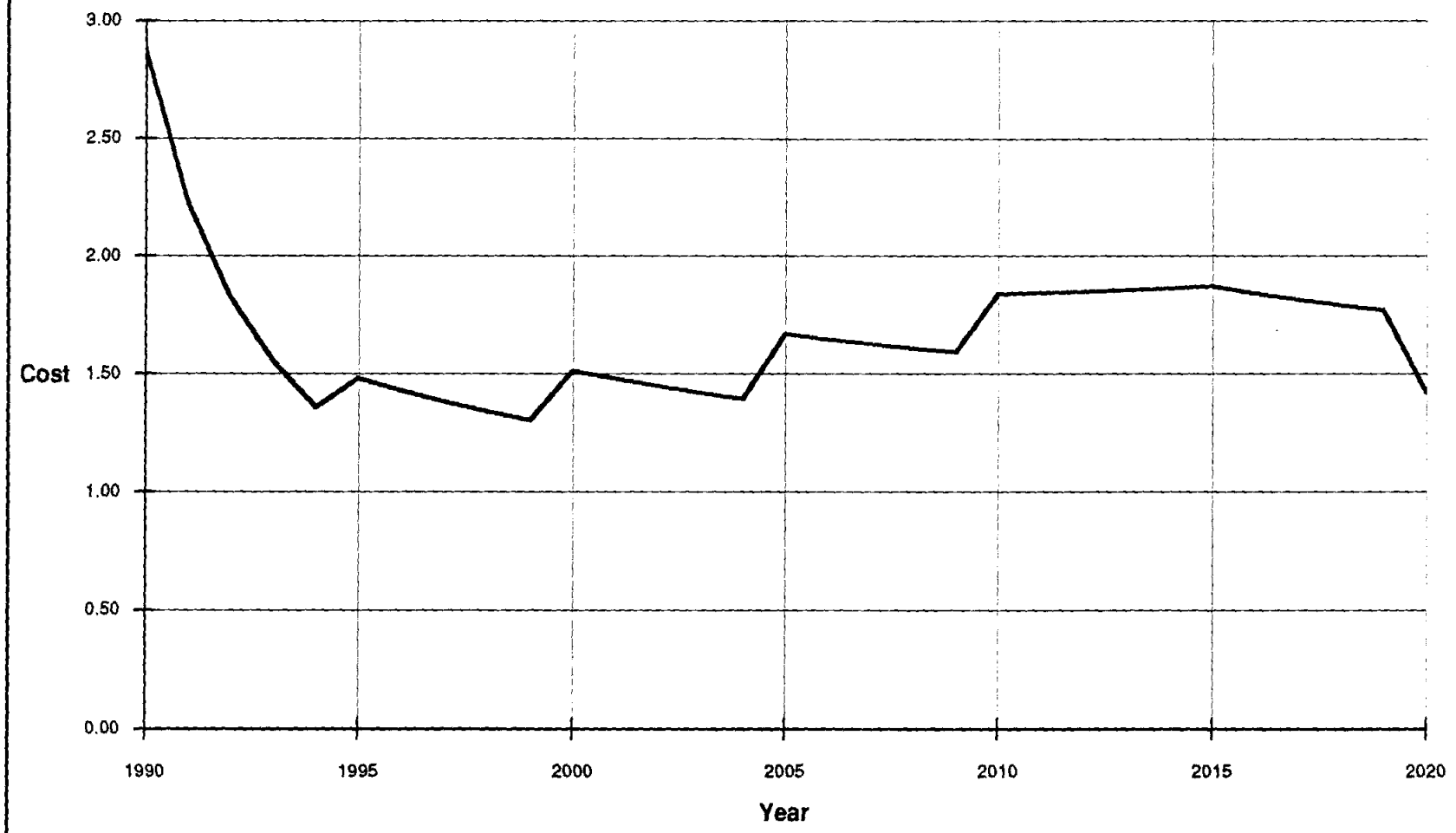

Figure 7-17  
Total Annual Cost of Carrizo-Wilcox Water

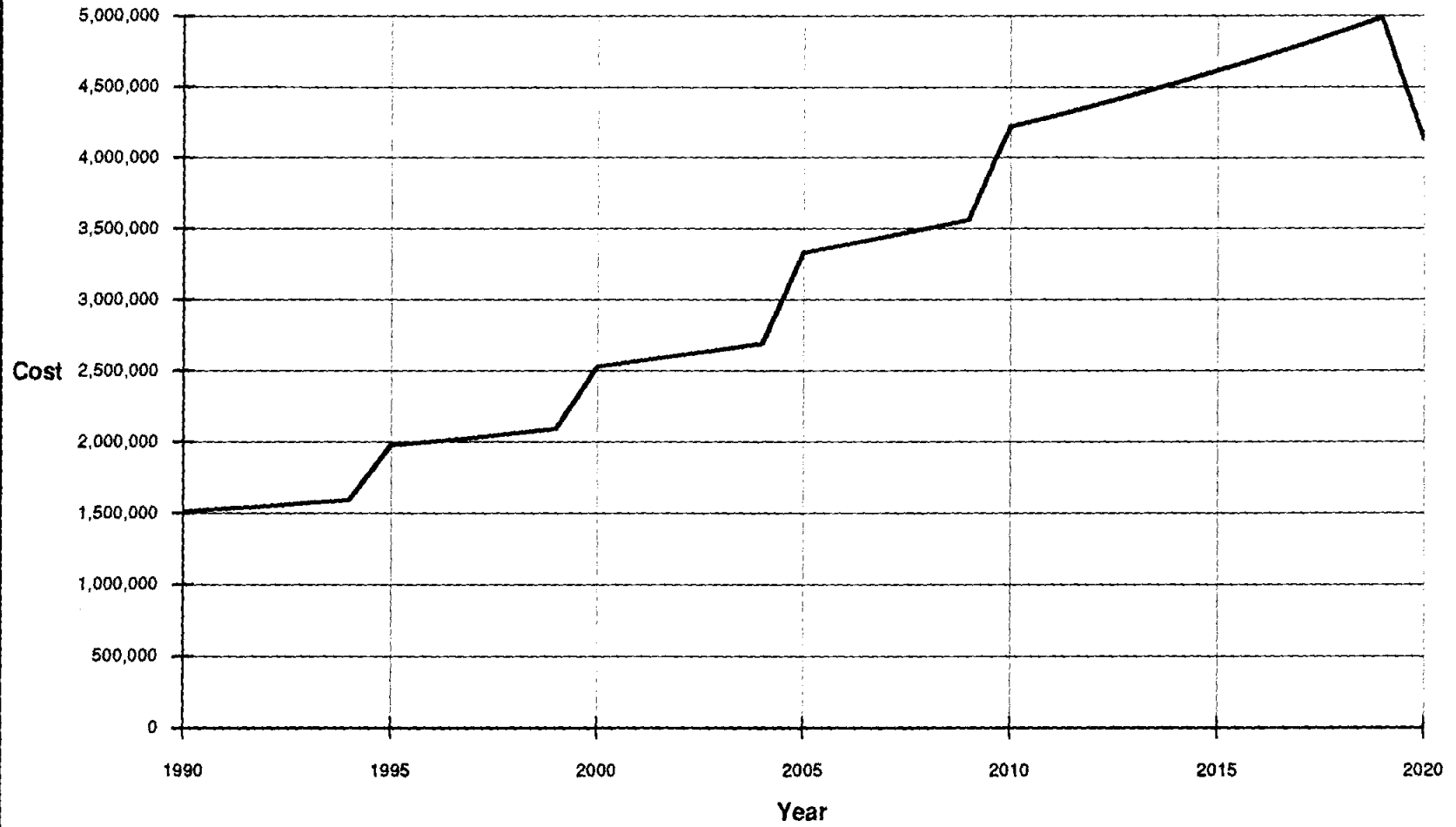
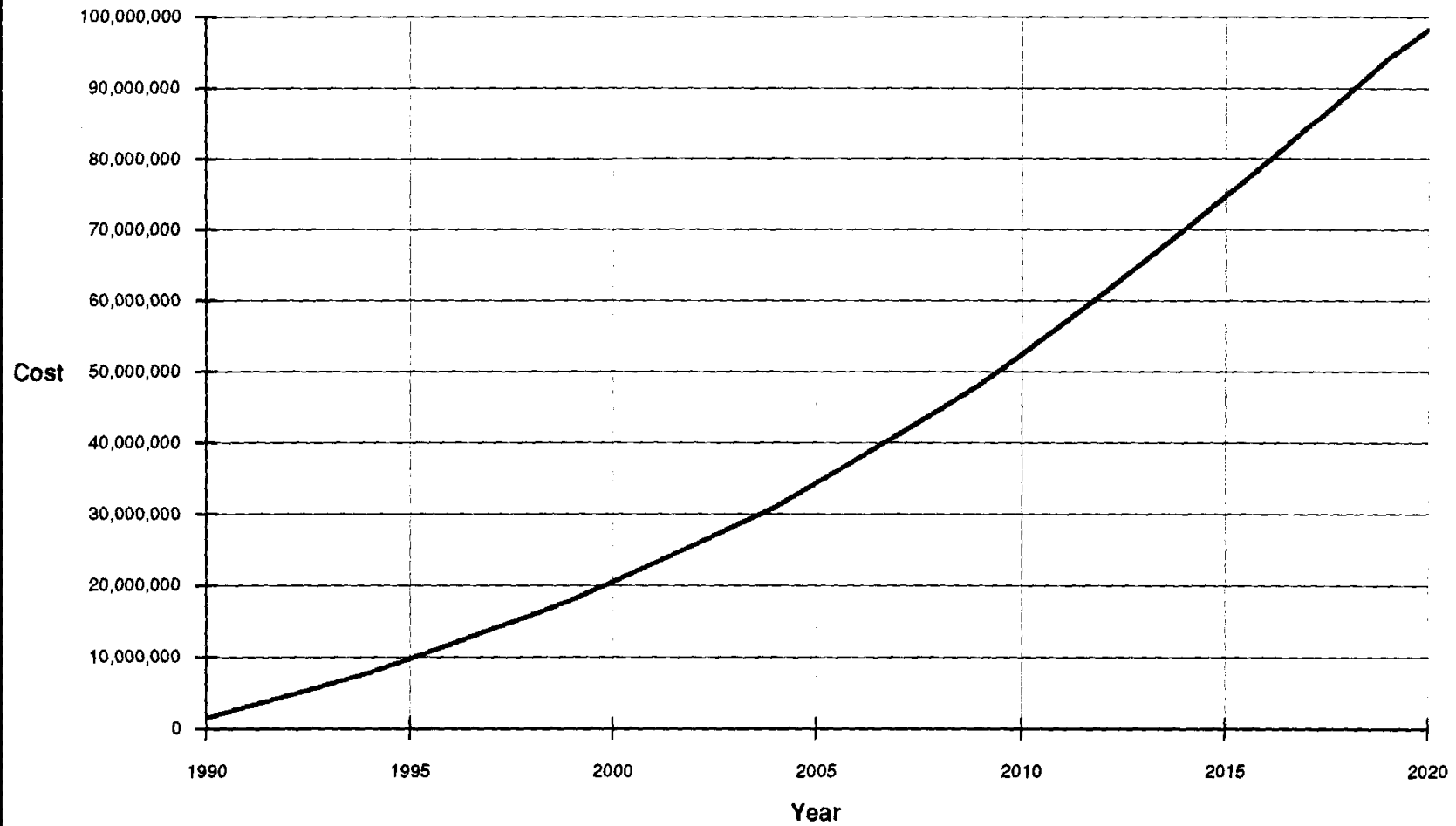

Figure 7-18  
Cumulative Cost of Carrizo-Wilcox Water



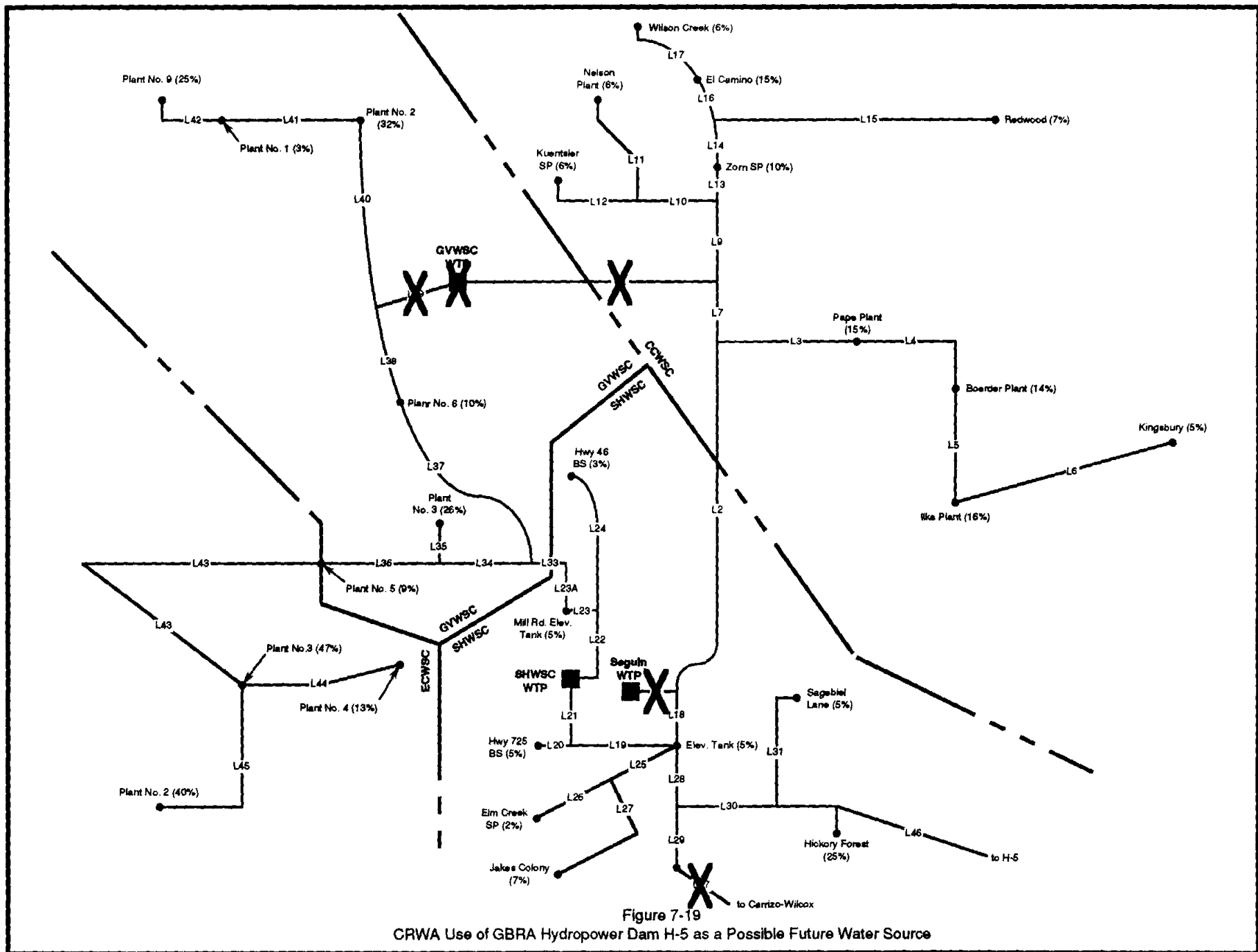

Figure 7-19

CRWA Use of GBRA Hydropower Dam H-5 as a Possible Future Water Source

**Table 7-42**  
**Phase I Installation of Major Transmission Mains**  
**CRWA Construct Surface Water Treatment Plant at GBRA Hydrodam H-5**

Line Designation	Design Flow Rate (MGD)	Design Velocity (FPS)	Calculated Pipe Diameter (In)	Design Pipe Diameter (In)	Actual Velocity (FPS)	Approximate Pipe Length (Ft)	Pipe Unit Cost (\$/Ft)	Estimated Cost of Pipe (\$)
L1	-	-	-	-	-	400	-	-
L2	1.83	5.0	10.2	12	3.6	44,000	12.00	\$528,000
L3	0.92	5.0	7.2	8	4.1	8,600	8.00	\$68,800
L4	0.64	5.0	6.0	8	2.8	16,000	8.00	\$128,000
L5	0.38	5.0	4.7	8	1.7	30,000	8.00	\$240,000
L6	0.09	5.0	2.3	4	1.6	32,000	-	-
L7	0.92	5.0	7.2	8	4.1	5,000	8.00	\$40,000
L8	-	-	-	-	-	46,000	-	-
L9	0.92	5.0	7.2	8	4.1	14,000	8.00	\$112,000
L10	0.22	5.0	3.5	6	1.7	22,000	4.50	\$99,000
L11	0.11	5.0	2.5	4	1.9	22,000	-	-
L12	0.11	5.0	2.5	4	1.9	16,000	-	-
L13	0.70	5.0	6.3	8	3.1	15,000	8.00	\$120,000
L14	0.51	5.0	5.4	6	4.0	4,000	4.50	\$18,000
L15	0.13	5.0	2.7	4	2.3	17,000	-	-
L16	0.38	5.0	4.7	6	3.0	8,000	4.50	\$36,000
L17	0.11	5.0	2.5	4	1.9	22,000	-	-
L18	1.83	5.0	10.2	12	3.6	14,000	12.00	\$168,000
L19	3.43	5.0	14.0	16	3.8	8,000	16.00	\$128,000
L20	0.02	5.0	1.1	4	0.4	2,600	-	-
L21	3.41	5.0	13.9	16	3.8	4,600	16.00	\$73,600
L22	3.24	5.0	13.5	16	3.6	9,400	16.00	\$150,400
L23	3.22	5.0	13.5	16	3.6	7,000	16.00	\$112,000
L23A	3.20	5.0	13.5	16	3.5	800	16.00	\$12,800
L24	0.01	5.0	0.9	4	0.2	13,000	-	-
L25	0.04	5.0	1.5	4	0.7	22,000	-	-
L26	0.01	5.0	0.7	4	0.2	8,000	-	-
L27	0.03	5.0	1.3	4	0.5	50,000	-	-
L28	5.32	5.0	17.4	18	4.7	10,000	20.00	\$200,000
L29	0.01	5.0	0.9	4	0.2	11,000	-	-
L30	5.34	5.0	17.4	18	4.7	12,000	20.00	\$240,000
L31	0.02	5.0	1.1	4	0.4	16,000	-	-
L32	5.36	5.0	17.4	18	4.7	14,000	20.00	\$280,000
L32A	0.11	5.0	2.5	4	2.0	18,000	-	-
L33	3.20	5.0	13.5	14	4.6	6,000	14.00	\$84,000
L34	1.81	5.0	10.1	12	3.6	10,000	12.00	\$120,000
L35	0.42	5.0	4.9	6	3.3	4,000	4.50	\$18,000
L36	1.39	5.0	8.9	10	3.9	10,000	10.00	\$100,000
L37	1.39	5.0	8.9	10	4.0	8,000	10.00	\$80,000
L38	1.19	5.0	8.2	10	3.4	13,000	10.00	\$130,000
L39	-	-	-	-	-	5,300	-	-
L40	1.19	5.0	8.2	10	3.4	26,500	10.00	\$265,000
L41	0.56	5.0	5.6	8	2.5	31,500	8.00	\$252,000
L42	0.50	5.0	5.3	6	3.9	16,000	4.50	\$72,000
L43	1.21	5.0	8.3	12	2.4	42,000	12.00	\$504,000
L44	0.16	5.0	3.0	6	1.2	32,000	4.50	\$144,000
L45	0.48	5.0	5.2	8	2.1	18,000	8.00	\$144,000
L46	5.47	5.0	17.6	30	1.7	142,000	45.00	\$6,390,000
L47	-	-	-	-	-	50,000	-	-
<b>Total Estimated Major Line Cost</b>								<b>\$11,057,600</b>

**Table 7-43**  
**Phase II Installation of Major Transmission Mains**  
**CRWA Construct Surface Water Treatment Plant at GBRA Hydrodam H-5**

Line Designation	Design Flow Rate (MGD)	Design Velocity (FPS)	Calculated Pipe Diameter (In)	Design Pipe Diameter (In)	Actual Velocity (FPS)	Approximate Pipe Length (Ft)	Pipe Unit Cost (\$/Ft)	Estimated Cost of Pipe (\$)
L1	-	-	-	-	-	400	-	-
L2	0.37	5.0	4.6	6	2.9	44,000	4.50	\$198,000
L3	0.19	5.0	3.2	4	3.3	8,600	-	-
L4	0.13	5.0	2.7	4	2.3	16,000	-	-
L5	0.08	5.0	2.1	4	1.4	30,000	-	-
L6	0.02	5.0	1.0	4	0.3	32,000	-	-
L7	0.19	5.0	3.2	6	1.5	5,000	4.50	\$22,500
L8	-	-	-	-	-	46,000	-	-
L9	0.19	5.0	3.2	4	3.3	14,000	-	-
L10	0.04	5.0	1.6	4	0.8	22,000	-	-
L11	0.02	5.0	1.1	4	0.4	22,000	-	-
L12	0.02	5.0	1.1	4	0.4	16,000	-	-
L13	0.14	5.0	2.8	4	2.5	15,000	-	-
L14	0.10	5.0	2.4	4	1.8	4,000	-	-
L15	0.03	5.0	1.2	4	0.5	17,000	-	-
L16	0.08	5.0	2.1	4	1.4	8,000	-	-
L17	0.02	5.0	1.1	4	0.4	22,000	-	-
L18	0.37	5.0	4.6	6	2.9	14,000	4.50	\$63,000
L19	2.00	5.0	10.6	12	3.9	8,000	12.00	\$96,000
L20	0.03	5.0	1.4	4	0.6	2,600	-	-
L21	1.96	5.0	10.5	12	3.9	4,600	12.00	\$55,200
L22	1.69	5.0	9.8	10	4.8	9,400	10.00	\$94,000
L23	1.67	5.0	9.7	10	4.7	7,000	10.00	\$70,000
L23A	1.64	5.0	9.6	10	4.7	800	10.00	\$8,000
L24	0.02	5.0	1.1	4	0.4	13,000	-	-
L25	0.06	5.0	1.8	4	1.1	22,000	-	-
L26	0.01	5.0	0.9	4	0.2	8,000	-	-
L27	0.05	5.0	1.6	4	0.8	50,000	-	-
L28	2.46	5.0	11.8	12	4.8	10,000	12.00	\$120,000
L29	0.02	5.0	1.1	4	0.4	11,000	-	-
L30	2.48	5.0	11.9	12	4.9	12,000	12.00	\$144,000
L31	0.03	5.0	1.4	4	0.6	16,000	-	-
L32	2.51	5.0	11.9	12	4.9	14,000	12.00	\$168,000
L32A	0.17	5.0	3.1	6	1.3	18,000	4.50	\$81,000
L33	1.64	5.0	9.6	10	4.7	6,000	10.00	\$60,000
L34	1.26	5.0	8.5	10	3.6	10,000	10.00	\$100,000
L35	0.11	5.0	2.5	4	2.0	4,000	-	-
L36	1.15	5.0	8.1	10	3.3	10,000	10.00	\$100,000
L37	0.38	5.0	4.6	6	3.0	8,000	4.50	\$36,000
L38	0.32	5.0	4.3	6	2.6	13,000	4.50	\$58,500
L39	-	-	-	-	-	5,300	-	-
L40	0.32	5.0	4.3	6	2.6	26,500	4.50	\$119,250
L41	0.15	5.0	2.9	6	1.2	31,500	4.50	\$141,750
L42	0.14	5.0	2.8	4	2.4	16,000	-	-
L43	1.10	5.0	7.9	10	3.1	42,000	10.00	\$420,000
L44	0.14	5.0	2.8	6	1.1	32,000	4.50	\$144,000
L45	0.44	5.0	5.0	6	3.5	18,000	4.50	\$81,000
L46	2.68	5.0	12.3	-	-	142,000	-	-
L47	-	-	-	-	-	50,000	-	-
<b>Total Estimated Major Line Cost</b>								<b>\$2,380,200</b>

CANYON REGIONAL WATER SUPPLY STUDY  
DETAILED COST EVALUATION

Total costs for Option 5 phased installation of treatment and distribution facilities, taken forward at an annual inflation rate of 4% per year to the actual date of expenditure, are shown in Tables 7-44 and 7-45. Total annualized cost for Option 5 installation, is shown in Table 7-46. Total CRWA cost per 1,000 gal, total annual costs and total cumulative costs (all assuming no rate-leveling financing mechanisms in place) for Option 5 are shown in Figures 7-20 through 7-22.

### 7.9 Summary Option Cost Comparison

Cost comparisons on a per thousand gallons treated and distributed, annual and cumulative basis for the five supply options are shown in Figures 7-23 through 7-25. The costs of Options 1-3, Purchase water from GBRA with treatment by CRWA, Purchase treated water from GBRA and Purchase water from GBRA with treatment by the City of Seguin, compare favorable with each other. With the exception of the first few years which could be leveled through creative financing, all three option costs increase gradually from approximately \$1.25 per 1,000 gallons in 1990 to \$1.80 per 1,000 gallons in 2015. Option 3, Develop well fields in the Carrizo-Wilcox Formation, is more expensive because of the combined costs of transmission from the well field to the service area and the costs of removal of iron. Option 5, Appropriate surface water downstream of GBRA hydropower dam H-5, is uneconomical because of the high cost of transmission from the diversion point near Gonzales to the CRWA service area.

### 7.10 Costs of Option 1 for Each CRWA Member WSC

The cost to each CRWA member WSC of the preferred option is a function of the amount of water used and the capacity of each line of the distribution system use by each entity (Tables 7-47 and 7-48). In the beginning, GVWSC, CCWSC and ECWSC would incur larger costs than SHWSC due to their greater dependence on the Edwards Aquifer as a primary water supply source (Figures 7-26 through 7-28). However, starting in about 1995, SHWSC demands increase steadily. After 2005 SHWSC and ECWSC will pay higher costs due to the additional transmission lines necessary to deliver water to their respective service areas.



Table 7-44  
Estimated Treatment Costs  
Appropriation Without Impoundment Below GBRA Hydrodam H-5 a/

Function	Total Cost						
	1990	1995	2000	2005	2010	2015	2020
1. Construction Cost							
a. Pumping Facilities	\$175,000	\$25,000	\$26,125	-	\$45,024	-	-
b. Treatment Works	\$2,500,000	\$1,824,979	\$2,220,366	-	\$3,286,685	-	-
c. Transmission Mains	\$0	\$0	\$0	-	\$0	-	-
2. Engineering (b/)	\$133,750	\$92,499	\$112,325	-	\$166,585	-	-
3. Land (c/)	\$100,000	\$100,000	\$100,000	-	\$100,000	-	-
4. Surveying and Staking (d/)	\$80,250	\$55,499	\$67,396	-	\$99,951	-	-
5. Legal and Administration (e/)	\$66,875	\$46,249	\$56,162	-	\$83,293	-	-
6. Permitting and Fees (f/)	\$53,500	\$37,000	\$44,930	-	\$66,634	-	-
7. Contingencies (g)	\$267,500	\$184,998	\$224,849	-	\$333,171	-	-
<b>Total</b>	<b>\$3,376,875</b>	<b>\$2,366,225</b>	<b>\$2,851,952</b>	<b>-</b>	<b>\$4,181,343</b>	<b>-</b>	<b>-</b>

- a/ All costs assumes 1990 dollars inflated a 4% per year..
- b/ Assumes 5% of total construction cost.
- c/ Based on current estimated cost of \$5,000/acre.
- d/ Based on 3% of construction cost.
- e/ Based on 2.5% of construction cost.
- f/ Based on 2% of construction cost.
- g/ Based on 10% of construction costs.

Table 7-45  
Estimated Transmission Line Costs  
Appropriation Without Impoundment Below GBRA Hydrodam H-5 a/

Function	Total Cost						
	1990	1995	2000	2005	2010	2015	2020
1. Construction Cost							
a. Pumping Facilities	\$0	-	-	\$0	-	-	-
b. Treatment Works	\$0	-	-	\$0	-	-	-
c. Transmission Mains	\$11,057,600	-	-	\$4,286,606	-	-	-
2. Engineering (b/)	\$552,880	-	-	\$214,330	-	-	-
3. Land (c/)	\$0	-	-	\$0	-	-	-
4. Surveying and Staking (d/)	\$331,728	-	-	\$331,728	-	-	-
5. Legal and Administration (e/)	\$276,440	-	-	\$276,440	-	-	-
6. Permitting and Fees (f/)	\$221,152	-	-	\$221,152	-	-	-
7. Contingencies (g)	\$1,105,760	-	-	\$1,105,760	-	-	-
<b>Total</b>	<b>\$13,545,560</b>	<b>-</b>	<b>-</b>	<b>\$6,436,016</b>	<b>-</b>	<b>-</b>	<b>-</b>

- a/ All costs assumes 1990 dollars inflated a 4% per year..
- b/ Assumes 5% of total construction cost.
- c/ Based on current estimated cost of \$5,000/acre.
- d/ Based on 3% of construction cost.
- e/ Based on 2.5% of construction cost.
- f/ Based on 2% of construction cost.
- g/ Based on 10% of construction costs.

Table 7-46  
Cost Analysis of Conjunctive Use of GBRA Hydropower Dam H-5 Supply Option

Year	Capital Well a/	O&M Well b/	Capital Well c/	O&M Well b/	Capital Well d/	O&M Well b/	Capital Well e/	O&M Well b/	Well Cost	Capital Line f/	O&M Line b/	Capital Line g/	O&M Line b/	Line Cost	Demand (MGD)	Pumped (MGD)	Cost of Water	Total Cost h/	Cumulative Cost	Cost/1,000 gal. Treated
1990	287,579	125,000							412,579	982,218	552,880			1,535,098	1.44	1.44	0	1,947,877	1,947,877	3.71
1991	287,579	130,000							417,579	982,218	574,995			1,557,213	1.88	1.88	0	1,974,792	3,922,469	2.87
1992	287,579	135,200							422,779	982,218	597,995			1,580,213	2.32	2.32	0	2,002,992	5,825,461	2.38
1993	287,579	140,608							428,187	982,218	621,915			1,604,133	2.77	2.77	0	2,032,320	7,957,781	2.01
1994	287,579	146,232							433,811	982,218	646,791			1,628,010	3.21	3.21	0	2,062,821	10,020,602	1.78
1995	287,579	152,082	206,837	92,770					739,267	982,218	672,683			1,654,881	3.65	3.65	0	2,394,148	12,414,750	1.80
1996	287,579	158,165	206,837	96,481					749,061	982,218	699,570			1,681,788	3.84	3.84	0	2,430,849	14,845,599	1.74
1997	287,579	164,491	206,837	100,340					759,247	982,218	727,552			1,708,771	4.02	4.02	0	2,469,018	17,314,617	1.68
1998	287,579	171,071	206,837	104,354					769,840	982,218	756,654			1,738,873	4.21	4.21	0	2,508,713	19,823,330	1.63
1999	287,579	177,914	206,837	108,528					780,857	982,218	786,921			1,768,139	4.39	4.39	0	2,549,996	22,373,326	1.59
2000	287,579	185,031	206,837	112,869	251,648	112,870			1,156,833	982,218	818,367			1,800,616	4.58	4.58	0	2,957,449	25,330,774	1.77
2001	287,579	192,432	206,837	117,384	251,648	117,385			1,173,264	982,218	851,133			1,833,352	4.76	4.76	0	3,006,615	28,337,390	1.73
2002	287,579	200,129	206,837	122,079	251,648	122,080			1,190,352	982,218	885,179			1,867,397	4.94	4.94	0	3,057,749	31,395,138	1.70
2003	287,579	208,134	206,837	126,962	251,648	126,963			1,208,123	982,218	920,586			1,902,804	5.11	5.11	0	3,110,927	34,506,066	1.67
2004	287,579	216,460	206,837	132,041	251,648	132,042			1,226,806	982,218	957,409			1,938,628	5.29	5.29	0	3,166,233	37,672,299	1.64
2005	287,579	225,118	206,837	137,322	251,648	137,324			1,245,827	982,218	995,706	211,427	119,010	2,306,361	5.47	5.47	0	3,554,188	41,226,487	1.78
2006	287,579	234,123	206,837	142,815	251,648	142,817			1,265,818	982,218	1,035,534	328,857	123,770	2,470,379	5.63	5.63	0	3,738,197	44,962,685	1.82
2007	287,579	243,488	206,837	148,528	251,648	148,529			1,286,608	982,218	1,076,955	328,857	128,721	2,516,752	5.80	5.80	0	3,803,360	48,766,044	1.80
2008	287,579	253,227	206,837	154,489	251,648	154,470			1,308,230	982,218	1,120,033	328,857	133,870	2,564,979	5.98	5.98	0	3,873,209	52,639,253	1.78
2009	287,579	263,358	206,837	160,648	251,648	160,649			1,330,717	982,218	1,164,835	328,857	139,225	2,615,135	6.13	6.13	0	3,945,851	56,585,104	1.78
2010	287,579	273,890	206,837	167,074	251,648	167,075	372,501	167,073	1,893,677	982,218	1,211,428	328,857	144,794	2,667,297	6.29	6.29	0	4,560,974	61,146,078	1.99
2011	287,579	284,846	206,837	173,756	251,648	173,758	372,501	173,756	1,924,681	982,218	1,259,885	328,857	150,586	2,721,548	6.38	6.38	0	4,646,227	65,792,305	1.99
2012	287,579	296,240	206,837	180,707	251,648	180,709	372,501	180,706	1,956,926	982,218	1,310,281	328,857	156,608	2,777,965	6.47	6.47	0	4,734,891	70,527,196	2.00
2013	287,579	308,089	206,837	187,935	251,648	187,937	372,501	187,934	1,990,460	982,218	1,362,692	328,857	162,873	2,836,640	6.57	6.57	0	4,827,101	75,354,297	2.01
2014	287,579	320,413	206,837	195,452	251,648	195,454	372,501	195,452	2,025,336	982,218	1,417,200	328,857	169,388	2,897,663	6.66	6.66	0	4,922,999	80,277,296	2.03
2015	287,579	333,230	206,837	203,270	251,648	203,272	372,501	203,270	2,061,607	982,218	1,473,888	328,857	176,164	2,961,127	6.75	6.75	0	5,022,734	85,300,030	2.04
2016	287,579	346,559	206,837	211,401	251,648	211,403	372,501	211,401	2,099,329	982,218	1,532,843	328,857	183,210	3,027,129	6.89	6.89	0	5,126,457	90,426,487	2.01
2017	287,579	360,421	206,837	219,857	251,648	219,860	372,501	219,857	2,138,599	982,218	1,594,157	328,857	190,539	3,095,771	7.24	7.24	0	5,234,330	95,660,817	1.98
2018	287,579	374,838	206,837	228,652	251,648	228,654	372,501	228,651	2,179,359	982,218	1,657,923	328,857	198,160	3,167,159	7.48	7.48	0	5,348,518	101,007,335	1.96
2019	287,579	389,831	206,837	237,798	251,648	237,800	372,501	237,797	2,221,791	982,218	1,724,240	328,857	206,087	3,241,402	7.73	7.73	0	5,463,193	106,470,528	1.94
2020		405,425	206,837	247,310	251,648	247,312	372,501	247,309	1,978,341		1,793,210	328,857	214,330	2,336,397	7.97	7.97	0	4,314,738	110,785,265	1.48

- a/ Based on an initial capital expenditure of \$3,237,500 in 1990 and amortized at 8% APR for 30 years.
- b/ 0.05% of construction cost inflated at 4% per year.
- c/ Based on a capital expenditure of \$1,913,900 (1990 dollars) inflated at 4% per year to 1995 (\$2,328,522) and amortized at 8% APR for 30 years.
- d/ Based on a capital expenditure of \$1,913,900 (1990 dollars) inflated at 4% per year to 2000 (\$2,833,000) and amortized at 8% APR for 30 years.
- e/ Based on a capital expenditure of \$1,913,900 (1990 dollars) inflated at 4% per year to 2010 (\$4,193,500) and amortized at 8% APR for 30 years.
- f/ Based on an initial capital expenditure of \$6,340,000 in 1990 and amortized at 8% APR for 30 years.
- g/ Based on a capital expenditure of \$2,055,700 (1990 dollars) inflated at 4% per year to 2005 (\$3,702,200) and amortized at 8% APR for 30 years.
- h/ Procurement, treatment and distribution.

Figure 7-20  
Cost/1,000 gal of Appropriation Below  
GBRA Hydropower Dam H-5

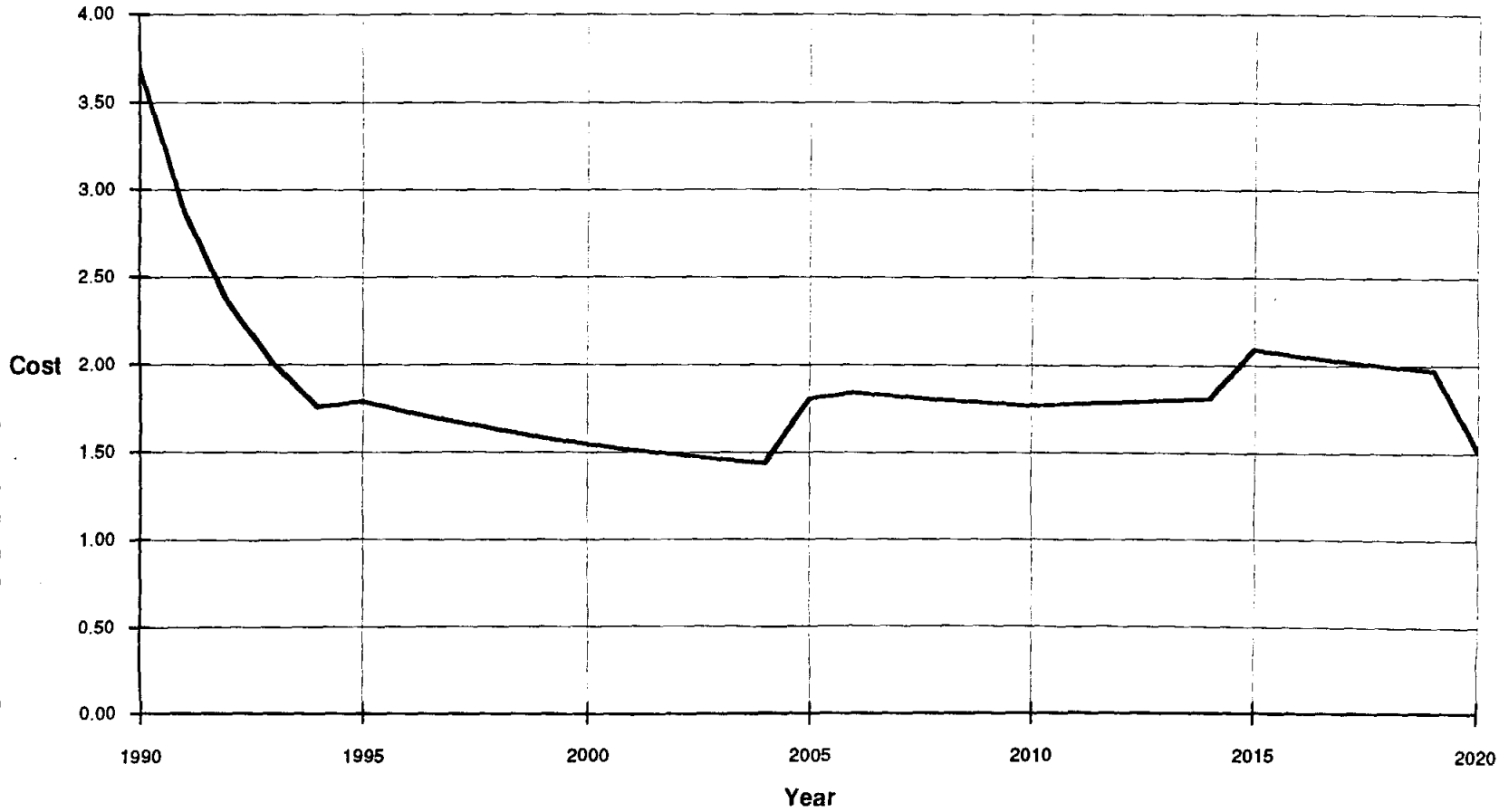

Figure 7-21  
Total Annual Cost of Appropriation Below  
GBRA Hydropower Dam H-5

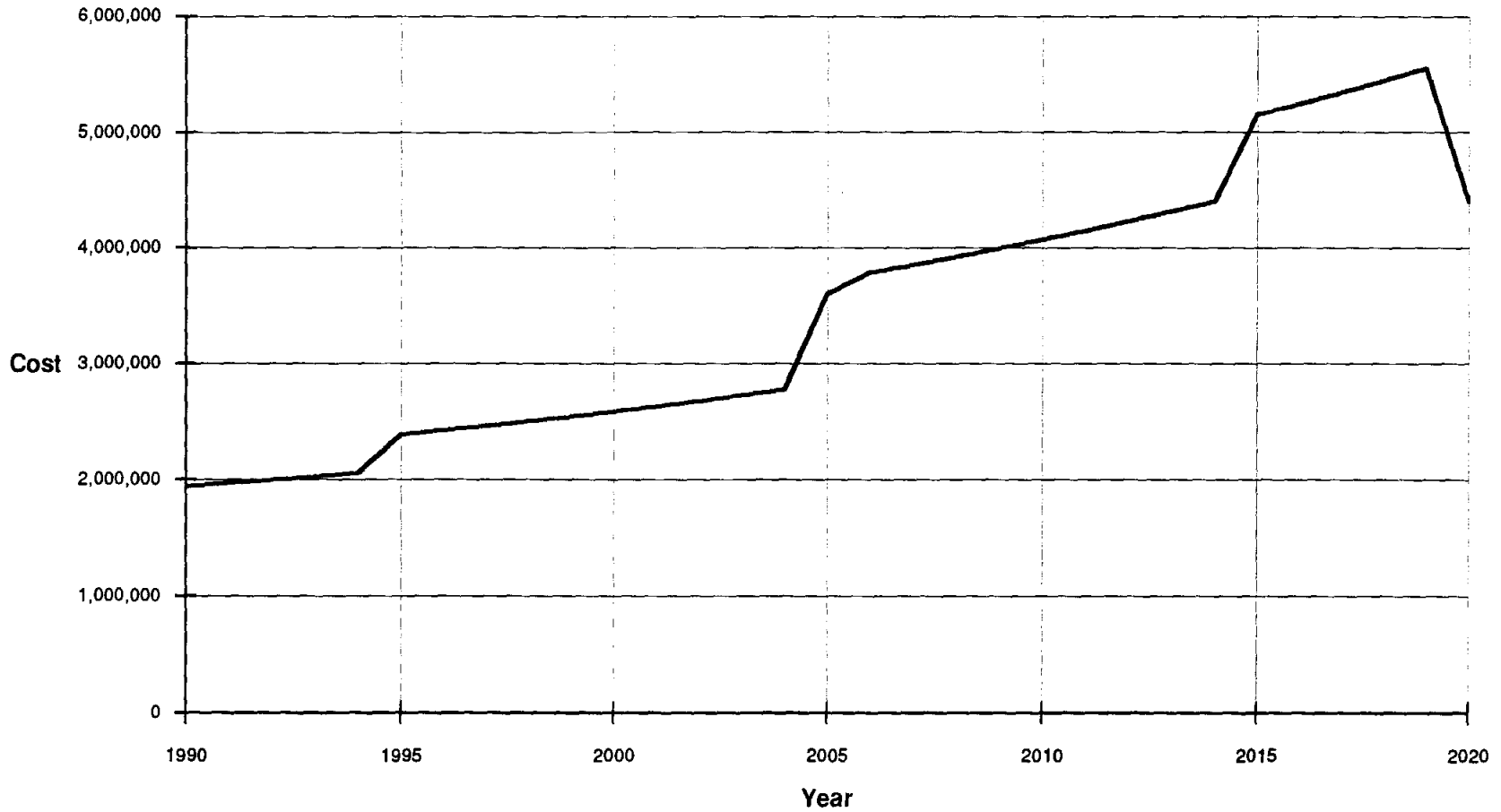

Figure 7-22  
Cumulative Cost of Appropriation Below  
GBRA Hydropower Dam H-5

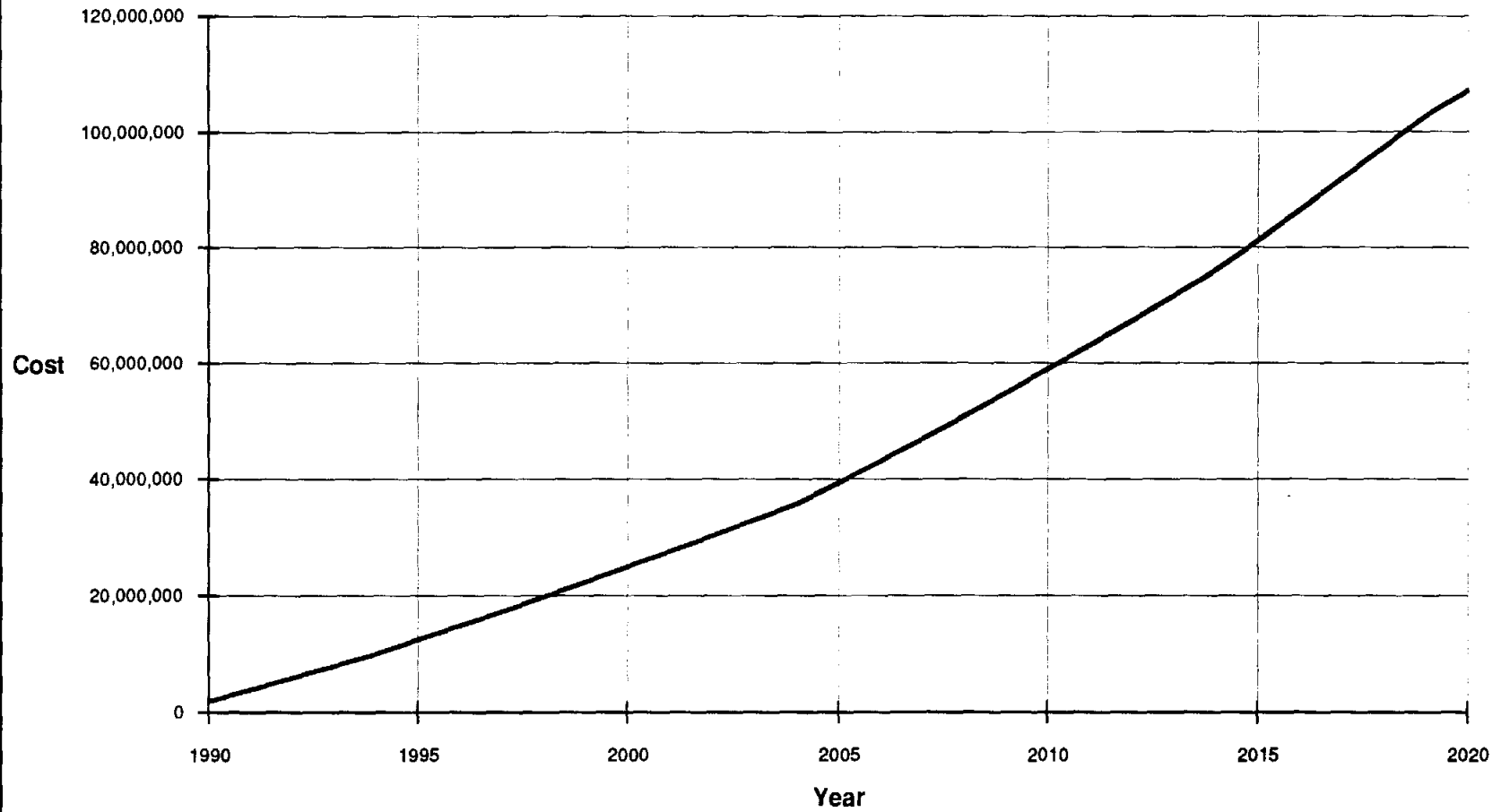

Figure 7-23  
Cost/1,000 gal of Major CRWA Supply Options

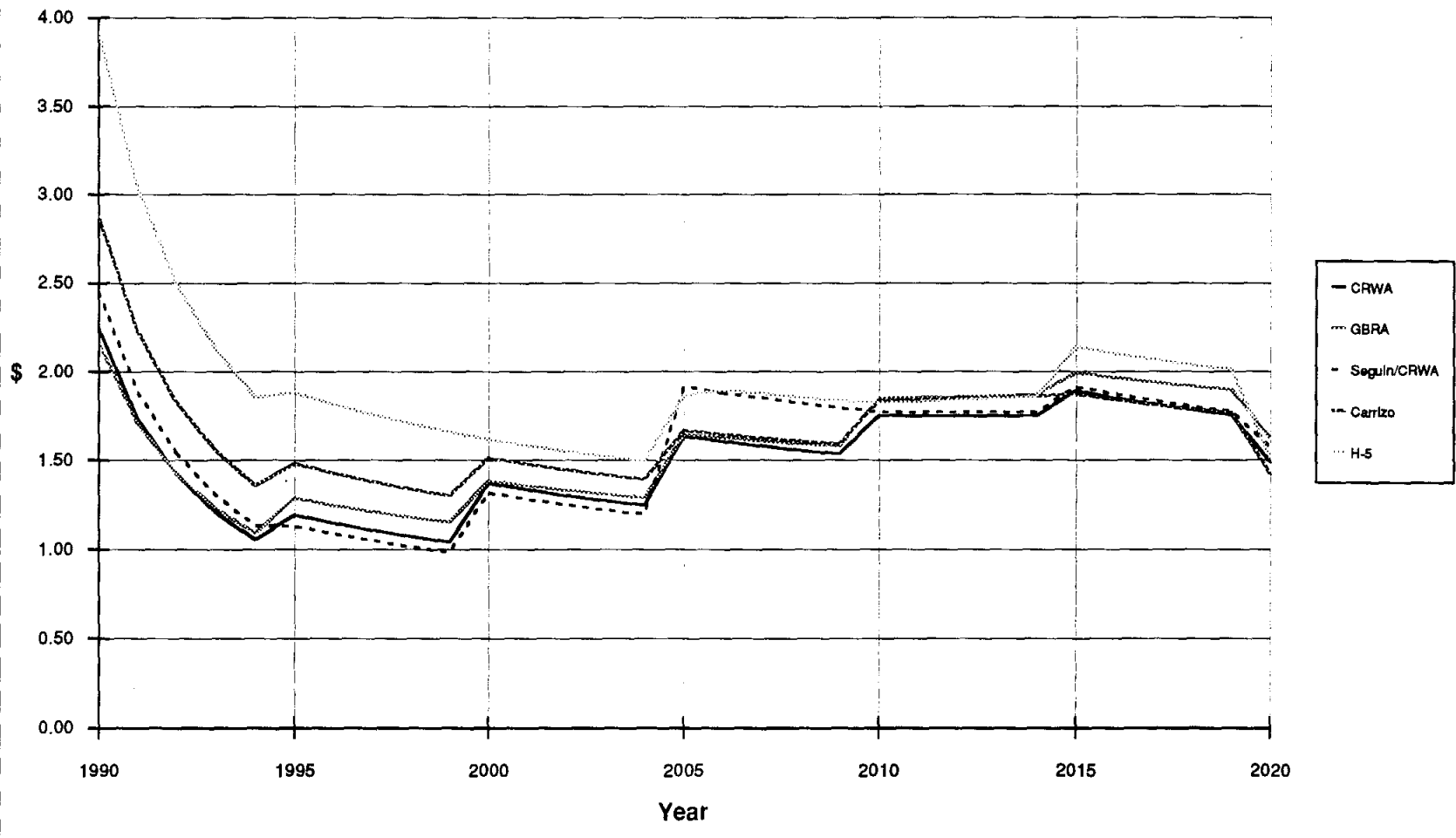

Figure 7-24  
Total Annual Cost of Major CRWA Supply Options

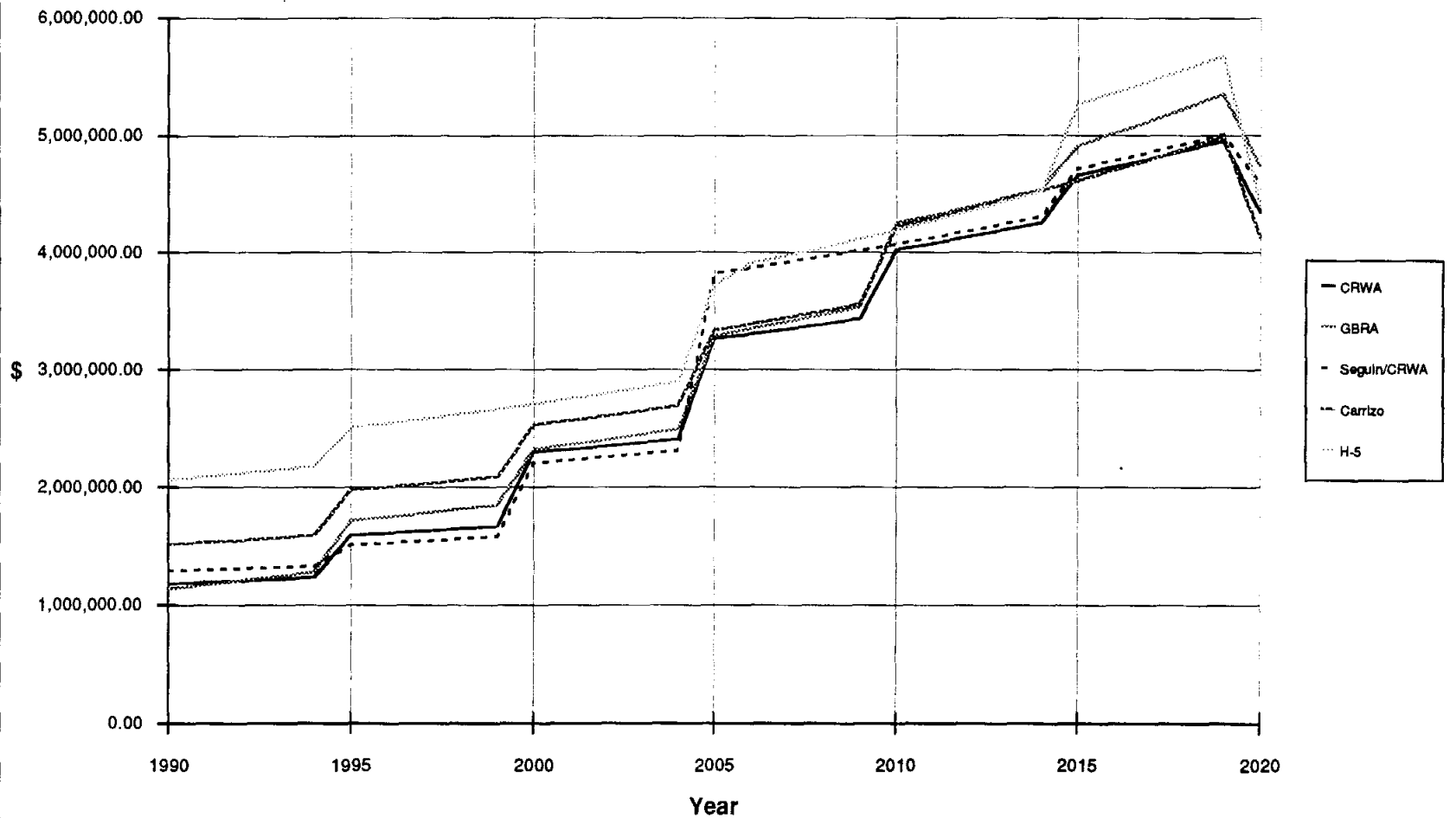

Figure 7-25  
Cumulative Cost of Major CRWA Supply Options

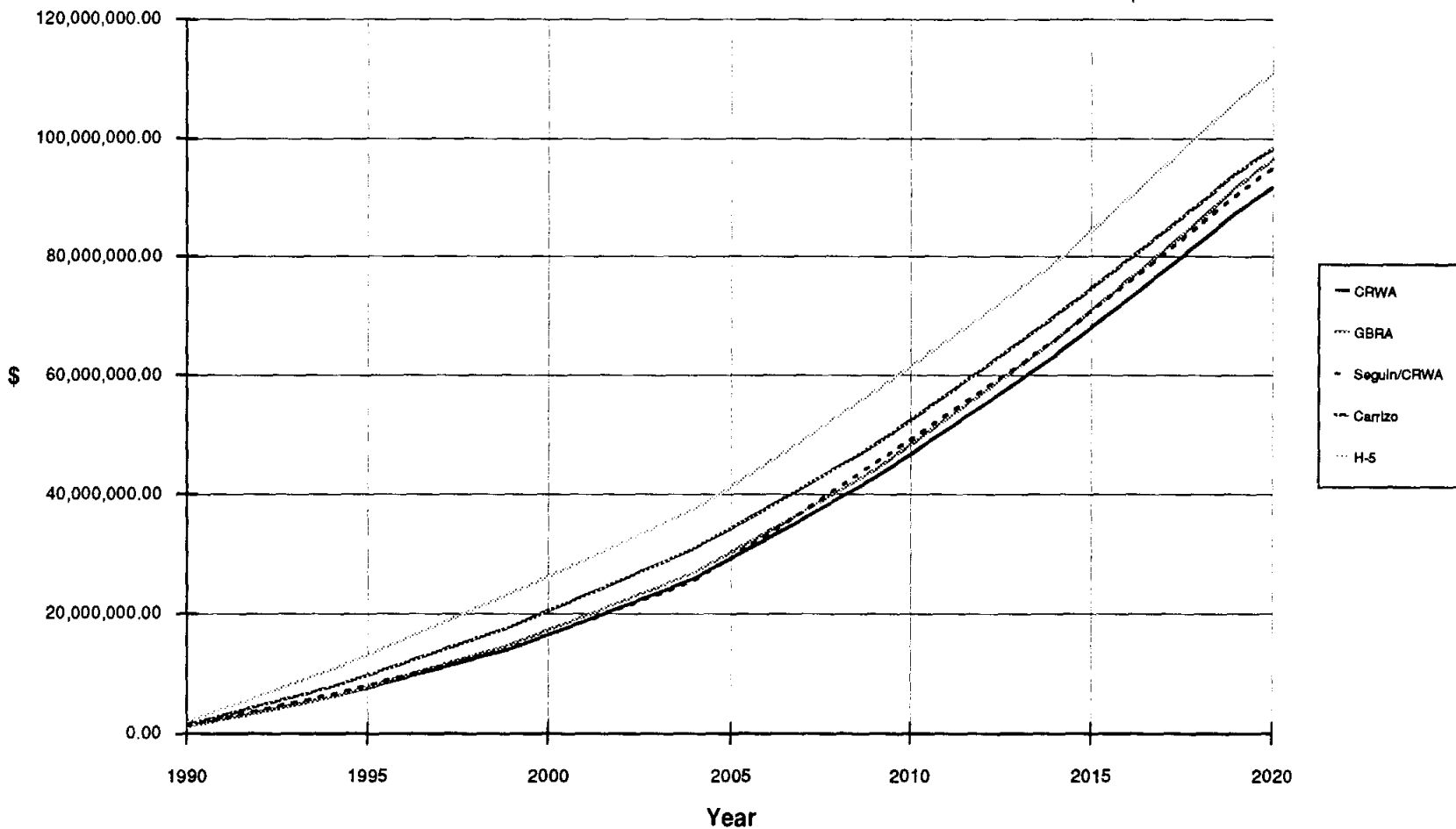



Table 7-47  
Phase I Installation of Major Transmission Lines (1990-2005)  
Purchase Water from GBRA with CRWA Transmission Supply Option

Line	Flow (MGD)	Flow Breakdown By Water Supply Corporation a/	Total Estimated Line Cost	Cost Participation By Water Supply Corporation			
				Green Valley WSC	Springs Hill WSC	Crystal Clear WSC	East Central WSC
L1	-	-	-	-	-	-	-
L2	-	-	-	-	-	-	-
L3	0.92	.50CC	\$68,800	\$0	\$0	\$68,800	\$0
L4	0.64	.35CC	\$128,000	\$0	\$0	\$128,000	\$0
L5	0.38	.21CC	\$240,000	\$0	\$0	\$240,000	\$0
L6	0.09	.05CC	-	-	-	-	-
L7	0.92	.50CC	\$40,000	\$0	\$0	\$40,000	\$0
L8	1.83	1.0CC	\$644,000	\$0	\$0	\$644,000	\$0
L9	0.92	.50CC	\$112,000	\$0	\$0	\$112,000	\$0
L10	0.22	.12CC	\$99,000	\$0	\$0	\$99,000	\$0
L11	0.11	.06CC	-	-	-	-	-
L12	0.11	.06CC	-	-	-	-	-
L13	0.70	.38CC	\$120,000	\$0	\$0	\$120,000	\$0
L14	0.51	.28CC	\$18,000	\$0	\$0	\$18,000	\$0
L15	0.13	.07CC	-	-	-	-	-
L16	0.38	.21CC	\$36,000	\$0	\$0	\$36,000	\$0
L17	0.11	.06CC	-	-	-	-	-
L18	-	-	-	-	-	-	-
L19	0.21	.47SH	-	-	-	-	-
L20	0.02	.05SH	-	-	-	-	-
L21	0.23	.52SH	-	-	-	-	\$0
L22	0.40	.92SH	\$42,300	\$0	\$42,300	\$0	\$0
L23	0.42	.95SH	\$31,500	\$0	\$31,500	\$0	\$0
L23A	0.44	1.0SH	\$3,600	\$0	\$3,600	\$0	\$0
L24	0.01	.03SH	-	-	-	-	-
L25	0.04	.09SH	-	-	-	-	-
L26	0.01	.02SH	-	-	-	-	-
L27	0.03	.07SH	-	-	-	-	-
L28	0.15	.33SH	-	-	-	-	-
L29	0.01	.03SH	-	-	-	-	-
L30	0.13	.30SH	-	-	-	-	-
L31	0.02	.05SH	-	-	-	-	-
L32	0.11	.25SH	-	-	-	-	-
L32A	0.11	.25SH	-	-	-	-	-
L33	0.21	1.0SH	-	-	-	-	-
L34	2.43	.30GV + 1.0CC	\$120,000	\$29,481	\$0	\$90,370	\$0
L35	0.42	.21GV	\$18,000	\$18,000	\$0	\$0	\$0
L36	1.39	.09GV + 1.0EC	\$100,000	\$12,885	\$0	\$0	\$87,050
L37	2.25	.30GV + 1.0SH + 1.0EC	\$96,000	\$25,472	\$18,773	\$0	\$51,627
L38	2.45	.40GV + 1.0SH + 1.0EC	\$156,000	\$50,684	\$28,016	\$0	\$77,045
L39	3.64	1.0GV + 1.0SH + 1.0EC	\$84,800	\$46,360	\$10,251	\$0	\$28,189
L40	1.19	.60GV	\$265,000	\$265,000	\$0	\$0	\$0
L41	0.56	.28GV	\$252,000	\$252,000	\$0	\$0	\$0
L42	0.50	.25GV	\$72,000	\$72,000	\$0	\$0	\$0
L43	1.21	1.0EC	\$504,000	\$0	\$0	\$0	\$504,000
L44	0.16	.13EC	\$144,000	\$0	\$0	\$0	\$144,000
L45	0.48	.40EC	\$144,000	\$0	\$0	\$0	\$144,000
L46	-	-	-	-	-	-	-
L47	-	-	-	-	-	-	-
<b>TOTAL ESTIMATED COSTS</b>			<b>\$3,539,000</b>	<b>\$771,883</b>	<b>\$134,440</b>	<b>\$1,596,170</b>	<b>\$1,035,911</b>
<b>PERCENT SHARE BY WSC</b>				<b>21.81%</b>	<b>3.80%</b>	<b>45.10%</b>	<b>29.27%</b>

a/ "-" Indicates line not included in transmission system.

Table 7-48  
Phase II Installation of Major Transmission Lines (2005-2020)  
Purchase Water from GBRA with CRWA Transmission Supply Option

Line	Flow (MGD)	Flow Breakdown By Water Supply Corporation a/	Total Estimated Line Cost	Cost Participation By Water Supply Corporation			
				Green Valley WSC	Springs Hill WSC	Crystal Clear WSC	East Central WSC
L1	-	-	-	-	-	-	-
L2	-	-	-	-	-	-	-
L3	0.19	.50CC	-	\$0	\$0	-	\$0
L4	0.13	.35CC	-	\$0	\$0	-	\$0
L5	0.08	.21CC	-	\$0	\$0	-	\$0
L6	0.02	.05CC	-	-	-	-	-
L7	0.19	.50CC	-	\$0	\$0	-	\$0
L8	0.37	1.0CC	\$368,000	\$0	\$0	\$368,000	\$0
L9	0.19	.50CC	-	\$0	\$0	-	\$0
L10	0.04	.12CC	-	\$0	\$0	-	\$0
L11	0.02	.06CC	-	-	-	-	-
L12	0.02	.06CC	-	-	-	-	-
L13	0.14	.38CC	-	\$0	\$0	-	\$0
L14	0.10	.28CC	-	\$0	\$0	-	\$0
L15	0.03	.07CC	-	-	-	-	-
L16	0.08	.21CC	-	\$0	\$0	-	\$0
L17	0.02	.06CC	-	-	-	-	-
L18	-	-	-	-	-	-	-
L19	0.31	.47SH	\$36,000	-	\$36,000	-	-
L20	0.03	.05SH	-	-	-	-	-
L21	0.35	.52SH	\$20,700	-	\$20,700	-	\$0
L22	0.62	.92SH	\$42,300	\$0	\$42,300	\$0	\$0
L23	0.64	.95SH	\$31,500	\$0	\$31,500	\$0	\$0
L23A	0.67	1.0SH	\$6,400	\$0	\$6,400	\$0	\$0
L24	0.02	.03SH	-	-	-	-	-
L25	0.06	.09SH	-	-	-	-	-
L26	0.01	.02SH	-	-	-	-	-
L27	0.05	.07SH	-	-	-	-	-
L28	0.22	.33SH	-	-	-	-	-
L29	0.02	.03SH	-	-	-	-	-
L30	0.20	.30SH	-	-	-	-	-
L31	0.03	.05SH	-	-	-	-	-
L32	0.17	.25SH	-	-	-	-	-
L32A	0.17	.25SH	\$81,000	\$0	\$81,000	-	-
L33	0.31	1.0SH	\$27,000	\$0	\$27,000	-	-
L34	0.53	.30GV + 1.0CC	\$45,000	\$13,703	\$0	\$31,415	\$0
L35	0.11	.21GV	-	-	-	-	-
L36	1.15	.09GV + 1.0EC	\$100,000	\$4,226	\$0	\$0	\$95,652
L37	1.93	.30GV + 1.0SH + 1.0EC	\$96,000	\$8,058	\$33,326	\$0	\$54,715
L38	1.99	.40GV + 1.0SH + 1.0EC	\$156,000	\$16,933	\$52,523	\$0	\$86,231
L39	2.31	1.0GV + 1.0SH + 1.0EC	\$63,600	\$14,868	\$18,447	\$0	\$30,286
L40	0.32	.60GV	\$119,250	\$119,250	\$0	\$0	\$0
L41	0.15	.28GV	\$141,750	\$141,750	\$0	\$0	\$0
L42	0.14	.25GV	-	-	-	-	-
L43	1.10	1.0EC	\$420,000	\$0	\$0	\$0	\$420,000
L44	0.14	.13EC	\$144,000	\$0	\$0	\$0	\$144,000
L45	0.44	.40EC	\$144,000	\$0	\$0	\$0	\$144,000
L46	-	-	-	-	-	-	-
L47	-	-	-	-	-	-	-
TOTAL ESTIMATED COSTS			\$2,042,500	\$318,787	\$349,196	\$399,415	\$974,884
PERCENT SHARE BY WSC				15.61%	17.10%	19.56%	47.73%

a/ "-" Indicates line not included in transmission system.

Figure 7-26  
Cost/1,000 gal of Option 1 for Each WSC

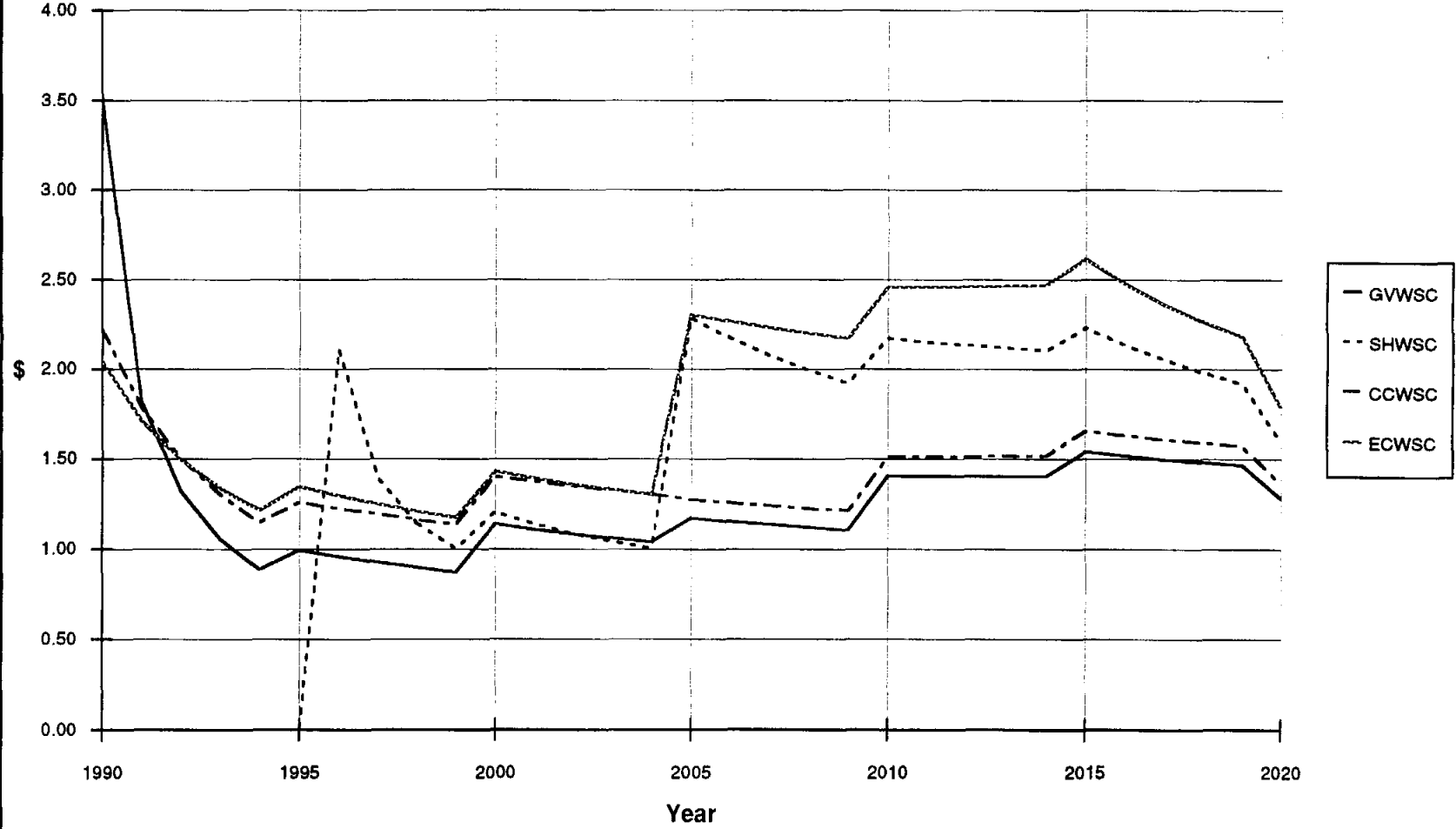

Figure 7-27  
Total Annual Cost of Option 1 for Each WSC

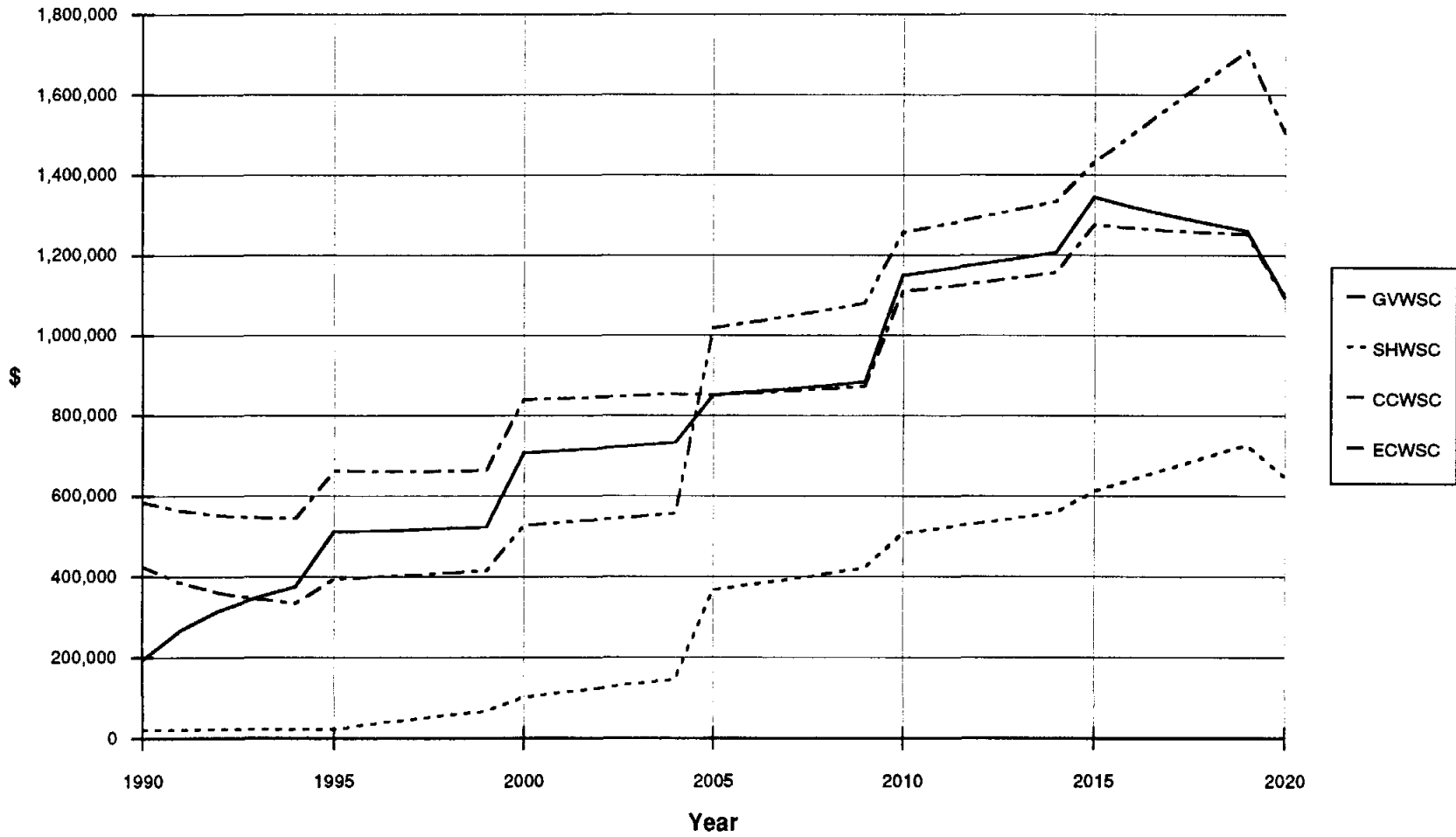
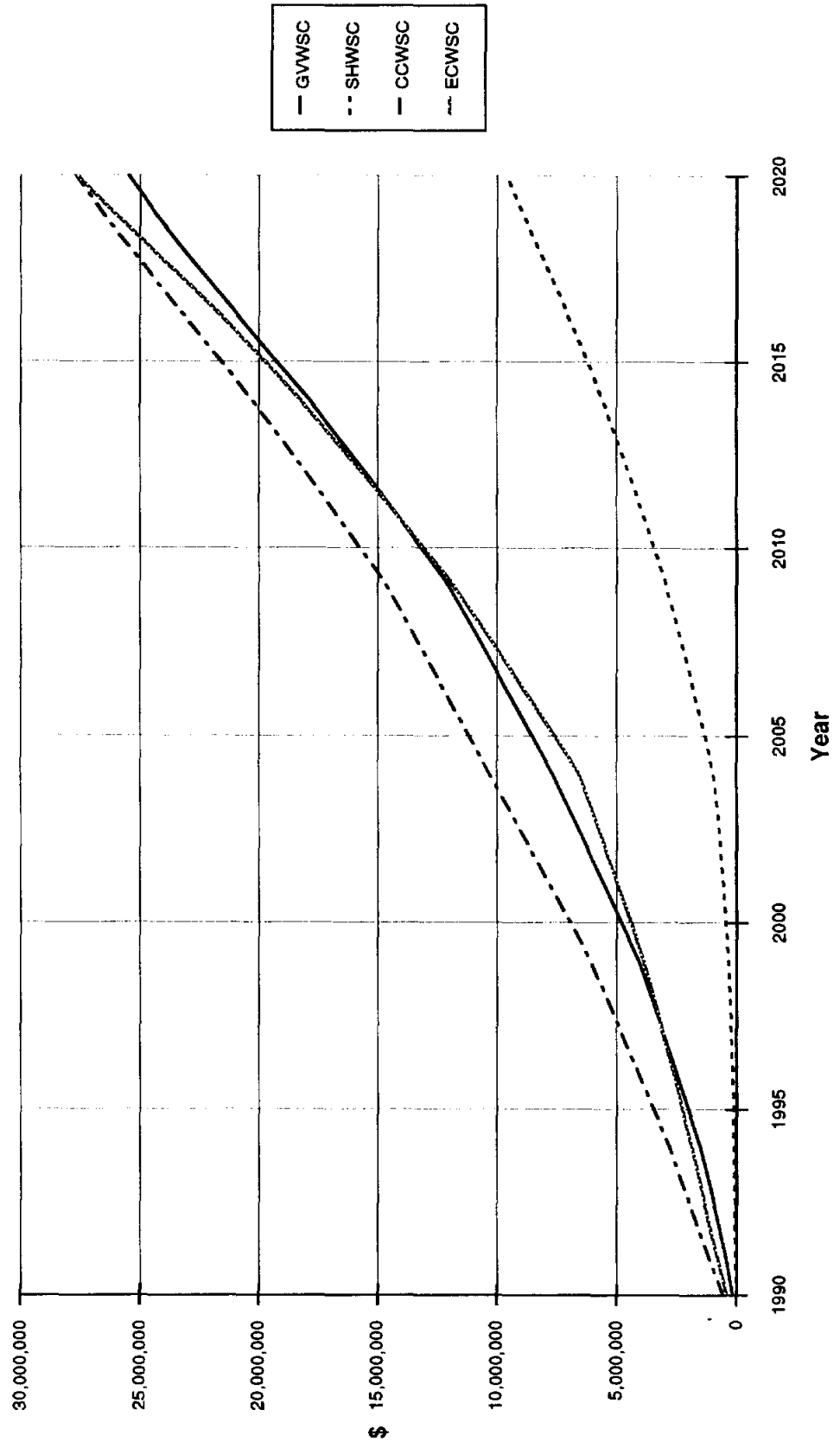

Figure 7-28  
 Cumulative Cost of Option 1 for Each WSC



## 8.0 INSTITUTIONAL AND LEGAL ISSUES

The current Regional Plan for Canyon Regional Water Authority focuses specifically on the water resource/water supply/water transmission requirements of four water supply corporations (Crystal Clear, East Central, Green Valley, and Springs Hill), with Certificates of Convenience and Necessity in Guadalupe, Bexar, Comal, Hayes and Wilson Counties.

In the initial Texas Water Development Board Grant Application by Canyon Regional Water Authority, the principal institutional and legal considerations were identified as 1) rights-of-way acquisition; 2) water rights; 3) inter-governmental contracting methods; and 4) regional water supply implications. Financial plan aspects focused on 1) projected revenues and 2) funding mechanisms.

In fact, while these are addressed in this portion of the report, institutional and legal considerations also must consider a broader picture because of the size of service area, water resource availability, and the potential for an effective regional system. This is particularly important in light of the current common resource from the Edwards Aquifer and the related litigation with impact on three river basins/river authorities. Institutional and legal considerations must also address:

1. How the regional authority will function in the five-county, three surface basins, two underground water district context;
2. How the regional authority will perform economically;
3. How the regional authority will establish governance and regulatory relationships;
4. How the regional authority will finance its development most effectively and pragmatically, including public/-private partnerships and rural economic development; and
5. How the regional authority will interface with emerging environmental requirements for small systems regionalization, sole-source groundwater controls, and wildlife/-wetlands issues.

### 8.1 Rights of Way Acquisition

In order to provide for the acquisition of requisite Rights of Way for transmission and storage facilities, Canyon Regional Water Authority has proviso for obtaining necessary land/easements through a number of civil or corporate authorities:

1. CRWA Statute (S.B. 1735, 1989 Legislative Session) provides
  - a. Section 2.04 a "FINDING OF BENEFIT under powers conferred by Article XVI, Section 59 of the Texas Constitution. . . to serve a public use and benefit;"

- b. Section 4.01(b) the power to "purchase, acquire, own, operate, maintain, repair, improve, or extend inside or outside the authority's boundaries any works, improvements, facilities, plants, equipment, and appliances necessary to accomplish the purposes for which it is created, including works, improvements, facilities, plants, equipments, and appliances incident, helpful, or necessary to purchase or otherwise acquire, treat, sell, wholesale, supply and deliver potable water for any purpose;" and
  - c. Section 4.03 "EMINENT DOMAIN. (a) The authority may exercise the power of eminent domain to acquire by condemnation a fee simple or other interest in property located in the territory of the authority if the property interest is necessary to exercise of the rights or authority conferred by this Act.
2. By authorizing statutes of the particular Contracting Parties.
  3. By use of Rights of Way in the public roadways with County or State authorization/approvals.
  4. By Eminent Domain as provided for in 1434 (a) Vernon's Annotated Texas Statutes as to Member Entities.

## **8.2 Water Rights**

In order to assure availability of water, CRWA must purchase or otherwise obtain sufficient water rights from available surface-or ground water resources. These include:

1. The Guadalupe-Blanco River Authority, through surface water resources available from Canyon Reservoir. Availability of this resource is on a "take-or-pay" basis and will require a substantial portion of the costs associated with the lessening of reliance on the Edwards Aquifer.
2. Other surface water sources, potentially available in the region if not allocated to or obtained by other/-competing water purveyors or restricted in terms of use by circumstances beyond the control of CRWA.
3. Increased pumpage from existing or new wells into the Edwards Aquifer or other ground water-bearing strata.
4. Impoundment of surface supplies in new reservoirs or diversion/storage sites from surface sources not currently allocated by State Permitting processes.

### 8.3 Intergovernmental Contracting Methods

Article 4413 (32c), Vernon's Texas Civil Statutes provides for Interlocal Cooperation to accomplish any of the purposes of powers the authority is authorized to carry out under S.B. 1735 (Section 4.08 - JOINT AUTHORITY). Representative of such inter-governmental agreements as may be devised is the present tripartite agreement among the Edwards Underground Water District, the Guadalupe-Blanco River Authority, and New Braunfels Utilities, wherein the Edwards District provides a financial underpinning for the purchase of water from Guadalupe-Blanco River Authority through Canyon Reservoir, enabling New Braunfels Utilities to abate its withdrawal of water from the Edwards Aquifer.

Since three of the four CRWA Member Entities currently receive a portion of their water supply from New Braunfels Utilities on a contractual basis and since the fourth Member Entity is a wholesale customer of the San Antonio City Water Board which is totally dependent on the Edwards Aquifer for its water resources, it is institutionally responsible for CRWA to negotiate a similar tripartite agreement in behalf of its water resource requirements. Additional aspects of intergovernmental cooperation will be addressed later in this Chapter.

### 8.4 Regional Water Supply Implications

It must be clearly understood that Canyon Regional Water Authority is not - - and does not intend to become - - a duplication of any other water wholesale entity. Similarly, its Member Entities do not intend to ignore the need to provide for their own resource requirements. Canyon Regional Water Authority - - because of its location and because of its Member Entities - - becomes the interstitial agency between the Guadalupe-Blanco and the San Antonio River Authorities, the Edwards Underground Water District, and area municipal, rural, and special district distribution systems.

Canyon Regional Water Authority must address the following institutional and legal issues as it enters its implementation phase:

1. It must solidify its existing organizational relationships.

Canyon Regional Water Authority began as a non-profit water supply corporation, becoming a legislatively-enacted entity in August 1989. Each of its Member Entities joined for specific, entity-based reasons. Some of the initial objectives and thrusts have changed since the formation of CRWA in July 1988, and these have placed stress on the original objectives and working relationships. The latter are emerging in what can be clearly identified as a maturing form; however, there is a lack of experience and understanding of regional cooperation, as well as some degree of skepticism within each of the Member Entities regarding CRWA. These concerns must be addressed as set forth below:



- a. Organizational structure. The current organizational structure is established to provide a cooperative working relationship among four independently-chartered, non-profit water supply corporations. Each Member Entity provides three Trustees, one of whom serves as an Officer and Member of the Executive Committee of Canyon Regional Water Authority. An Administrator has been appointed as the executive, and presently functions as the principal contact person for the four Member Entities.

This organizational structure has served CRWA well during its initial operations. However, as planning moves to implementation, the essentially ad hoc nature of CRWA will require additional flesh on the organizational bones. Trustees must make provision for revisions to governing documents (addressed in Section # 3 of these considerations). In addition, there must be immediate and strong efforts at "marketing" the concept of a regional wholesale water purveyor (addressed in Section # 2) in order to assure the economic and operating viability of Canyon Regional Water Authority as an independent entity. Devising an optimal organization structure is not the subject of this portion of the regional plan. It is, however, safe to say that the current structure will require streamlining and additional attention to administrative detail.

- b. Operating finances (post-planning/pre-customer). Canyon Regional Water Authority has, since its inception, financed its operations in an ongoing, cash-contribution basis. This "pay-as-you-go" effort has served CRWA well for start-up purposes and, presuming progression to operational status, will be a debt repaid to the Member Entities. At the same time, the "pay-as-you-go" approach has been accompanied by certain limiting factors associated with necessary goals.

Presuming the acceptance and implementation of the recommendations associated with this Regional Plan, CRWA must address acquiring and servicing sufficient "start-up" costs associated with implementation of the Plan and obtaining additional Member Entities. Penurious financing during start-up could limit the scope and effectiveness of CRWA in attracting new Members/Users at a critical time in sizing and constructing the system's infrastructure.

- c. Operating staff (post-planning/pre-customer). Operating staff now consists of an administrator who also is a full-time employee of one of the Member Entities. The ability of this individual to wear two hats and achieve the best interests of the regional entity, and the remaining three Member Entities of the regional whole is testimony to his managerial and organizational skills, as well as to his understanding of the complexities and vagaries of regionalization and consensus-building. He is joined in the interim management of CRWA by

managers of the other Member Entities, each of whom is equally committed to achieving the goals of a reliable and cost-effective water supplies for their Owner/Members.

Realistically, however, each of the system managers has a full-time responsibility to his individual system. Further, it is (at best) difficult to divorce individual system objectives and needs from that of a regional system, especially when the latter system is in an embryonic stage. Canyon Regional Water Authority - - after the planning process is completed and continuing through start-up to full implementation - - must immediately identify its critical staffing requirements (with particular attention to administrative, organizational, and marketing necessities, as opposed to operational needs), determine the costs and skills mix associated with that staffing need, assess financing strategies, and move to employ such personnel as required to reach operating status.

- d. Professional services requirements (post-planning/pre-customer). Canyon Regional Water Authority has, to date, attempted (with some degree of success) many of its projects on an ad hoc, volunteer basis. Professional services (engineering, legal, organizational, financial) have been compensated out of operating funds contributed by the Member Entities, with the premise that volunteer labor through the Board of Trustees and/or the Board of Mangers would be responsible for such activities as formal communications, legislation, grant/loan development, administrative tasks, and the like.

Additional staff dedicated solely to CRWA objectives and implementation activities will have a positive impact on professional costs. However, it should be pointed out that the need for legislative, contractual, financial packaging, and related aspects of implementation will continue to require professional time/fees. Further, at this critical stage of CRWA's development, those professional services may well include extensive liaising with Federal and State agencies in order to assure sufficient and timely availability of funding for the entire scope of the project in such a manner as to hold rate shock to a minimum. Institutionally, CRWA must determine and clearly define the scope and nature of its professional services relationships, delimit responsibility and authority of its professional service providers, and adequately budget for professional fees. This is especially critical if CRWA is to take advantage of pending Federal legislation, potential access to inter-agency grant funds, and the meshing of the State political entities which stand to support and/or benefit from CRWA's development.

2. It must proactively market its future product/service to potential Member/User entities. A marketing concept is essentially foreign to most water utilities. In the rural scenario, ownership is

joint, with the presumption that the "market" knows and meets the need. In the urban setting, ratepayers are conditioned to a "monopolistic" approach, with information and "salesmanship" available on a "need-to-know" basis. If Canyon Regional Water Authority becomes - - and remains - - a fully functional and successful wholesale water purveyor, its staff and professional consultants must adopt a marketing approach in all areas of operations, including regulatory and legislative affairs, the political arena(s), customer communication, employee relations, cost-of-service rates, revenue requirements, information systems, budgeting, public involvement and the like. Included with this marketing approach are these considerations:

- a. Determining requirements for "membership". Current Member Entities have made substantial financial contributions for ongoing operations, organizational and legislative activities, and a regional water plan. Future Member Entities will reap the results of this process which has selected the best option, developed cost and staging scenarios, and the initial investment of the current Member Entities.

With the addition of Customer and/or Member Entities, CRWA's Trustees, in conjunction with professional consultants, must determine the financial and contractual requirements to sit as a new Member Entity of CRWA. In addition, Trustees must set levels and extent of participation, parameters of membership (including whether a new Member Entity can serve as an intermediary wholesale entity), representation in governing affairs, representation in regional forums, and related areas of concern.

- b. Establishing methods for attracting and retaining new Member/User entities. Clearly, potential Member/User entities (which have access to inexpensive water from the Edwards Underground Water District) will be sorely tempted to elect the least expensive option, ignoring future supply and cost restraints as long as possible. Canyon Regional Water Authority must first develop a target constituency and a method by which it can reach and "sell" that target constituency on full participation in CRWA and its activities.

In order to achieve this objective, CRWA must establish a firm external marketing plan designed to attract new member or customer entities. At the same time, CRWA must assure the continued Owner/Member support and understanding from each of its four Member Entities and, where there is any indication of lack of understanding or dissatisfaction with CRWA and its development, defuse any potential disruptive actions. At the very least, public meetings, regular/periodic visits with target organizations, regular newsletters, and other public information vehicles must be developed, implemented, and continued on a regular basis.

CANYON REGIONAL WATER SUPPLY STUDY  
INSTITUTIONAL AND LEGAL ISSUES

- c. Obtaining firm indications of intent to join/purchase from CRWA. This concept includes full-scale joining the CRWA Board of Trustees, execution of preliminary letters of intent to participate, followed by signed contractual arrangements assuring execution of preliminary documents; and determination of and commitment to funding those aspects which can be done on a local/adjunct basis.
- d. Translating indications of intent into contracted water rights. A limited availability of surface water rights currently remains upon which to exercise options. At the same time, CRWA must explore the availability of alternative water systems (such as water re-use ) as a supplement to the expected availability of Canyon Reservoir water. Similarly, CRWA must determine how it will interact/interface with other legislated entities in its primary service area - - and in the surrounding region - - to protect its water resource development/use rights.
- e. Designing/developing/disseminating comprehensive information for varied segments of the "market" to assure positive institutional, legal, political, regulatory, and informational support for financing/construction/expansion alternatives. It is impossible to emphasize enough the need to create and take to the Owner/Members a clear descriptor of the service area, improvements, costs, benefits and the like.

Quite frankly, water utilities have, in general, postured themselves as the purveyors of "silent service." The "silent servicers" now are being asked to undertake "high-dollar" expense projects for which they are neither budgeted nor staffed. As a result, information and customer communication falls by the wayside. It therefore becomes important that the institutional and legal considerations consider and require the implementation of continuing customer communication vehicles.

- 3. It must integrate service areas/service requirements in its political subdivisions which include five counties (with a potential expansion to eight), three river basins, two underground water district (fractured), numerous municipalities, and various utility and other legislatively-created water purveyors. This will necessitate a review of infrastructure/relationships to include the following.
  - a. Contractual documents. Contractual arrangements must include those associated with purchasing or assuring long-term availability of raw surface water resources, either through the Guadalupe-Blanco River Authority (via Canyon Reservoir) or through other surface water sources which might be available. Similar contractual arrangements to be considered will be those for wholesale/retail purchasers of treated water, with such documents developed to provide for long-term customer stability, thus ensuring the financial integrity of the Authority. NOTE: Because CRWA involves trans-basin movement of water from/to Guadalupe-

Blanco/San Antonio Rivers, two approvals are necessary. Likewise, any CRWA transport of water by the Entity of its Members from the Edwards Underground Water District to locations off the Edwards/outside the District will require approval. (An example of this may be found in the interconnection of Bexar Metropolitan Water District with water users in portions of Bexar County which are outside the Edwards area. Such interconnections will require EUWD approval.)

- b. Interlocal cooperation agreements which address and protect both water supply corporation and municipal interests - - a generally unexplored territory in terms of "cooperation" which is made more complex by virtue of the numbers of diverse players having no common history.

Water Supply Corporations (generally rural in the past) have focused on availability of minimal amounts of potable water supplies and meeting of essential service requirements, usually residential in nature. Local ownership and control through mutual ownership associations with a commonality of community have formed the fabric of financing and governance. System master planning (specifically large-sized transmission lines, sufficient storage, proactive rat-making) has been limited in scope, with a more common focus being on "fire-fighting" local connection problems, financial considerations associated with line extensions, and paying off existing debt.

Municipal interests historically have viewed rural areas as beyond their scope of service until annexation for expansion of municipal tax base in consideration beneficial or until "urban flight" into an "exurban" area is perceived as a negative impact on municipal economic development. At such point, municipalities have attempted to exercise their governmental jurisdiction in heavy-handed ways resulting in "service/territorial litigation," resource curtailment (where the rural entity is a contractual "wholesale customer" of the municipality, with a resulting exercise of considerable legislative, regulatory and judicial pressure on the rural systems.)

This historical climate places all parties in an initially "reactive" posture, requiring careful communications, negotiations, and deft crafting of Interlocal Cooperation Agreement language which confers equitable power and benefits on all parties and which assures a process by which utility issues (such as service areas, costs, governance, emergency operations linkage, operating guidelines, long-term planning horizons) and related topics (such as economic development, quality of life, platting/zoning, education, public safety and other essential services) receive direct and fair attention from all parties.

c. Acquisition of required territory for treatment facilities, transmission lines, and storage requirements. The preferred option suggested by this Regional Plan will require development of a new surface water treatment plant, possible inter-location with other water sources (Edwards Underground Water District, New Braunfels Utilities, and Bexar Metropolitan Water District as examples), acquisition of easements and rights-of-way associated with construction of major transmission lines, and location and securing of property for significant regional-scale ground and elevated storage facilities. Presuming the addition of other entities - - municipal, water supply corporation or other - - institutional and legal issues could include purchase/lease of existing treatment facilities, linkage with existing or development of additional river authority treatment (water/wastewater) facilities, and a re-definition of size and location of requisite infrastructure. The scale of regional wholesale surface or ground water systems, treatment facilities, and transmission systems will require significant sizing considerations to cover not only reasonable planning horizons of 15-25 years, but also the mortgage requirements of debt instruments (25-40 years).

d. Active - - and regular - - interfacing with regulatory agencies, existing wastewater, water reuse and hydro-electric interests. Water conservation is clearly the current and future rallying point for state and Federal regulatory agencies. At least one special district has been created to address water reuse in at least a part of the Canyon Regional Water Authority service area (Alamo Conservation and Reuse District). CRWA has reuse/wastewater treatment as a part of its mission and authority.

Further, emphasis currently is placed on regionalization as a means by which small (marginal) systems can comply with State requirements for financial support. Regional scale is implicit in the Safe Drinking Water Act and related environmental quality requirements set in motion by national legislation and the Environmental Protection Agency. Rate-making requirements, state-of-the-art treatment technology, effective (and creative) water conservation methods, and selection and retention of qualified personnel to create and maintain the necessary communication and proactive posture demand advanced thinking and action on the part of CRWA, its membership, and its leadership. Because existing Trustees are long-term, experienced water professionals, the Board comes to its task with a wealth of experience and insight for the opportunity it faces to fill in the void in the organizational lattice between basin-wide authorities and local water supply corporation/municipal retail entities.

e. Modifying existing authorizing legislation, By-Laws, and other documents establishing and governing the Authority to reflect expansion of service area and inclusion of other Member/User entities. If Canyon Regional Water Authority is to become a fully functioning

and viable entity, it must attract other utilities having a common need, purpose, and sense of future-think. Those entities will bring requirements of representation, noticing of potential actions, operating/maintenance funds, and individual system requirements into the structure which currently encompasses a relatively homogeneous entity. Consensus-building among all current and potential Members will require adroit identification of areas of Commonality, as well as areas where differences must be negotiated. While CRWA is viewed initially in the "micro" system, the precedents have positive and significant State-wide implications and must be viewed at the outset as opportunities. Governance issues will have a Regional, State and Federal overlay in the regulatory and political processes. These leadership potentials have been evident since the Summer of 1988 and considered throughout CRWA's implementation efforts.

- f. Determining an equitable working relationship with the Edwards Underground Water District and with other, established special water agencies. The norm is established in the tripartite agreements cited earlier among New Braunfels Utilities, the Edwards Underground Water District, and the Guadalupe-Blanco River Authority. Because of the current reliance on Edwards water by each of the Member Entities, it is logical that similar working relationships can be established between the Edwards and CRWA - - IF CRWA takes the initiative and approaches the Edwards for both intangible and tangible support. Failure to seek said support can, however, lead to reallocation of funds leaving CRWA and its Member Entities missing a substantial economic resource presently available.
- g. Determining an equitable working relationship with the City of San Antonio and its various water-related entities (City Water Board, Department of Environmental Management, Alamo Conservation and Reuse District) presuming that the City elects to follow an independent course with regard to water issues. It is recognized that the City of San Antonio, as the largest population/usage entity in the five-county planning region, has a historical perspective of extensive withdrawal of groundwater resource to meet burgeoning municipal economic and residential needs. Although San Antonio has implemented various conservation and rate models to provide economic compensation for its withdrawal strategies, the immutable fact remains that San Antonio ratepayers currently use 7.5 times as much water as a "minimum" use and pay less than one-sixth what Canyon Regional Water Authority Member Entities pay for that same minimum.

Clearly, if the City of San Antonio is to benefit from reduced dependence on Edwards Aquifer water by CRWA 's Member and customer entities, those entities must receive some quid pro quo. San Antonio cannot operate in a vacuum because of its strategic position over the

Edwards Aquifer and because of its technical ability to extract the water resource not accessible to CRWA's Member and customer entities.

Whether the City of San Antonio "participates" in the development of CRWA in the form of a municipal grant to assist in the construction of infrastructure, a "per account" assessment for a finite time period to assist with construction, a user contract to supply a portion of the City's potable water requirements, or some other pricing/support mechanism is less relevant than is the requirement that the City of San Antonio shoulder some of the direct burden of relieving dependence on its current - - and, quite probably, principal future - - water resource in return for assuring a greater quantity of that resource for its populace.

4. Canyon Regional Water Authority must develop a feasible financing outline/funding proposal which will limit the chilling effect of rate shock on the current rural customer base and which will encourage existing and potential Member/User entities to make commitments to long-term contractual relationships with the Authority. Clearly, this Regional Plan sets forth the business plan by which the current Member Entities can proceed to design, construction and actual operation of its system. However, given the significant disparity in water rates currently in existence, the additional cost (acquisition, capital improvements, debt service, and operations and maintenance) per thousand gallons requires the charting of new institutional and legal paths. These include:

- a. Identifying/developing local agency support. As part of its formative efforts, Canyon Regional Water Authority already has established contact and working relationships with the Alamo Area Council of Governments, the Edwards Underground Water District, and most of the municipal, county, river authority, and special use districts within its service area. It also has an historical relationship with Guadalupe Valley Electric Cooperative and its wholly-owned economic development corporation, thus establishing a part of the public/private partnership which can enhance CRWA's posture for future financing. [NOTE: At this time, CRWA has not contacted the Evergreen Underground Water District in Wilson/Atascosa Counties concerning participation and/or involvement in CRWA's planning/implementation.]

While local support has been forthcoming, particularly in terms of oral and written commentary, there is clear demand for tangible support in the form of wholesale customers participant contracts with long-term contract commitment to sustain system and financial operations.

Priority must be given to establishing a workable plan for entity contacts and contracts. Strategies must be followed which will bring necessary agencies into a working relationship with CRWA in three to six months. This is especially critical if CRWA elects to proceed with



acquisition of water rights and construction of the recommended infrastructure. If borderline drought conditions, currently affecting the CRWA service area, worsen in the approaching summer months, a favorable public climate for prompt action will be further enhanced. Towards this end, a comprehensive listing of water purveyors and permitted entities has been obtained from the Texas Department of Health and the Texas Water Commission so that such a work plan may be established and administered. Further, the Authority is empowered to issue bonds or incur debt, as required, to meet its statutory reason for existence.

- b. Identifying/developing multiple State/Federal agency support including rural and exurban economic development, small system/regionalization requirements, sole-source groundwater supplies, and the increased emphasis on public/private partnership. Significant preliminary work has been undertaken in this arena, largely related to the enactment of State legislation establishing CRWA. The Texas Water Development Board, the Texas Water Commission, and the Texas Department of Health are familiar with CRWA's objectives and options. The Farmer's Home Administration, former financing agency for the four Member Entities, has a CRWA funding application pending. Additionally, it has followed CRWA's evolutionary process and has compared its potential success with that of other wholesale water suppliers it has funded. The governance and organizational structure of Central Texas Regional Water System, Beaver Water District (Lowell, AR) and The Woodlands Joint Powers Agency (The Woodlands, TX) have provided models for developing additional support.

Institutionally and legally, CRWA must focus its efforts on the impact it might have on rural (defined as pertaining to the country as opposed to the city), exurban (defined as small communities beyond the suburbs of a city) and urban (defined as pertaining to or comprising a city or town) economic development. It must become a building block in that economic foundation. It cannot afford the installation of piecemeal infra-structure components. Rather, it must be an active part of the planning and preparation processes associated with the wholesaling water into the less developed portions of the expanding Standard Metropolitan Statistical Area (SMSA) it serves. Accordingly, the survey of funding sources must include:

- (1) Local agencies such as the Edwards Underground Water District, Alamo Conservation and Reuse District, the City of San Antonio, Bexar Metropolitan Water District, Evergreen Underground Water District, various municipal and private companies, water supply corporations, Lackland City Water Company, Guadalupe Valley Electric Cooperative, and various area Chambers of Commerce which have a vested interest in economic development issues.

CANYON REGIONAL WATER SUPPLY STUDY  
INSTITUTIONAL AND LEGAL ISSUES

In addition, Cibolo Creek Municipal Authority is a potential source of water for treatment and distribution by securing water before its discharge to the Cibolo Creek or through acquisition of water via the proposed Stockdale Reservoir as the projected San Antonio River Authority - sponsored Bureau of Reclamation Cibolo Project.

- (2) State agencies such as the Texas Water Development Board's funding alternatives coupled with increasingly stringent regulatory requirements of the Texas Department of Health and the Texas Water Commission may translate into allocation of public works funds at the State level.
- (3) Federal demonstration grant, loan or regulatory programs, to wit
  - (a) Farmers Home Administration, U.S. Department of Agriculture. Seven percent (7%) loan program, bond purchase program or grants. Possible limits on total annual availability. Application has been pending since 1988. Authorization bill for funding, notably that associated with economic development issues, passed the U.S. House of Representatives on March 23, 1990.
  - (b) Economic Development Administration, U.S. Department of Commerce. Grant funds limited to one million; must create significant number of long-term jobs based on strict criteria. Must be funded in one fiscal year and can be packaged with FmHA, with FmHA as the administering agency.
  - (c) U.S. Environmental Protection Agency small systems program funds. Construction grants programs authority has expired; however, 3P (Public/Private Partnership program) offers a unique opportunity to demonstrate use of EPA grant funds in support of sole source aquifer protection, public/private partnership state-of-art treatment technology, regional operations set in an acceptable cost-of-service-based business plan, and bay and estuarine protection concerns, notably those associated with wetlands. National office allocation is the only source, and is dependent on availability of funds and appropriate packaging of request for funds to comply with national environmental priorities.
  - (d) Bureau of Reclamation, U.S. Department of Interior. This agency can provide planning support for reservoir construction, and possible regional support for sole source impact if the Endangered Species Act is involved. The agency will be assisted by the Bureau of Fisheries and Wildlife, also within the Department of Interior.

CANYON REGIONAL WATER SUPPLY STUDY  
INSTITUTIONAL AND LEGAL ISSUES

- (e) Soil Conservation Service, U.S. Department of Agriculture. A partnership program with local Soil Conservation Districts, with Federal construction of several reservoirs where rights-of-way are locally acquired. This option could be used in off-channel, small watershed storage projects if funding is not too backed up and if future construction is anticipated with sufficient lead time.
  - (f) Public Works Bill Authorization. This option will require a special rider to the omnibus bill through U.S. Representative Greg Laughlin to fund a U.S. Corps of Engineers/U.S. Bureau of Reclamation national demonstration project for protection of sole source aquifers, introduction of state-of-art treatment processes, multi-county regional distribution systems, demonstrating water reuse, transfer, and trans-basin surface/underground water management techniques in preservation of historic spring flow and endangered species protection at the Comal and San Marcos Springs, as well as for maintenance of fresh water flow for critical bays and estuaries.
  - (g) National Aeronautics and Space Administration/National Oceanographic and Atmospheric Administration. Civil use programs provide for environmental mapping of regional areas, reflecting topographic and other significant features for resource management. This source will be invaluable in providing maps, photos, and pictorial definitors of both Canyon Regional Water Authority and related and contiguous areas in the affected water complex.
  - (h) U.S. Decennial Census. Canyon Regional Water Authority's multi-region status and congruence with the San Antonio SMSA will provide updated census data in 1991, directly impacting the proposed five-year incremental planning for additional treatment/transmission/storage requirements.
  - (i) U.S. Environmental Protection Agency. Anticipated Congressional enactment of a National Plumbing Code mandating water conservation plumbing fixtures may have grant funds available. It is anticipated that this legislation will be directed primarily as a regulatory effort to reduce water consumption via faucets, commodes, and showerheads.
- c. Packaging local/state/Federal/private initiatives in a timely manner so as to proceed with system design and construction. With the planning phase coming to its end, it is important that CRWA move through its decision-tree matrix, deciding whether, when and how to proceed with the recommendations provided through the Regional Plan. This will require

CANYON REGIONAL WATER SUPPLY STUDY  
INSTITUTIONAL AND LEGAL ISSUES

- (1) the CRWA Board's evaluation of this Report;
- (2) the establishment of a strategic plan;
- (3) the selection of qualified professional firms to assist in implementation;
- (4) the access to whatever financial resources may be available; and
- (5) the recruiting of customers.

Most critical to success will be recruitment of sufficient wholesale customers, linkage with presently available water resources, and development of financial income to secure debt . . . all key elements in testing the Authority's ability to perform.

5. CRWA must integrate all aspects of the "emerging" regional system with equally "emerging" environmental requirements. The Member Entities of Canyon Regional Water Authority recognize clearly that the cost of water will escalate as treatment technology becomes more sophisticated, as water resources become more scarce, and as quality of life issues continue to take precedence. Having direct institutional and legal ramifications are:
  - a. Clearly identified endangered species now subject to scrutiny as part of the Guadalupe-Blanco River Authority lawsuit vis a vis the Edwards Aquifer. The recognized need for preservation of endangered species is but one aspect of this lawsuit. CRWA recognizes the need to assure water flow to support the aquatic environs. Similarly, CRWA recognizes the equally real need to implement water conservation methods on an interim basis as a means of environmental quality management. Finally, CRWA recognizes that, notwithstanding this Regional Plan, the Edwards Aquifer remains the primary (or the only) source of water currently available to their respective systems. The G-BRA/Edwards suit will provide an eventual balance in the "costs" and availability of water resources in the region. IN the interim, CRWA must make choices based on its understanding of the environmental requirements it may be required to implement.
  - b. Potential positive (direct and indirect) impact of reduced dependence on the Edwards Aquifer (by Canyon Regional Water Authority Member/Users) on coastal wetlands currently relying on stream flow from the Guadalupe-Blanco, San Antonio and Nueces Rivers. Wetlands have not received CRWA attention, as it attempts to define its regional role. While Federal and State agencies have primary responsibility for planning and implementation criteria concerning coastal wetlands, CRWA recognizes it has a limited role in assuring the viability of coastal shrimp and fishing industries, of breeding areas for whooping cranes, and of reduced

agricultural productivity in the face of saltwater intrusion absent sufficient freshwater flow. This wetlands concern is mentioned because of the potential for "consumptive" use of the regional water, thereby denying a portion of the historic streamflow from the affected river basins.

- c. Potential positive (direct and indirect) impact of downstream interests in assured continuing minimum streamflow from the Guadalupe-Blanco, San Antonio and Nueces Rivers. This Regional Plan is relatively small in scope. However, as it has developed it becomes obvious that Canyon Regional Water Authority, with its currently finite scope of service and impact, is clearly a "sub-region" of a much larger water resource planning area, consisting of three surface and two sub-surface areas. Clearly, the streamflow from the Nueces River to the City of Corpus Christi is affected by recharge of the Edwards Aquifer; agricultural interests in the Carrizo-Wilcox formation and Evergreen Water District; and wise water use and reuse in the Metropolitan San Antonio area clearly the streamflow from the San Antonio River to its juncture with the Guadalupe-Blanco Rivers and its ultimate flow into San Antonio/Copano Bay is critical to downstream municipal and agricultural water users, as well as to bay and estuarine interests. Clearly there are public policy reasons associated with assuring the artesian flow of springs in New Braunfels and San Marcos, with the concomitant preservation of endangered aquatic species and assurance of water resource for municipal and agricultural interests in that area.
- d. Mitigation requirements associated with endangered species agreements. CRWA is aware of the philosophies at Federal and State agencies to establish and enforce clear mitigation requirements associated with endangered species agreements. Insofar as reducing its dependence on Edwards Aquifer water resources will facilitate the preservation of historic spring flow and the resulting preservation of endangered species, this mandate clearly is supported by CRWA's institutional efforts, as well as its stated basis for legislative creation.

At the same time, CRWA believes that its efforts merit quid pro quo consideration by local, regional, municipal, water supply corporation, and environmental interests in assuring that reduced dependence on the Edwards does not wreak economic havoc by way of rate shock and disproportionate economic burden on its Member Entities and potential wholesale customers through unnecessarily greater comparative costs. The delicate balance between the endangered aquatic/biological specials and the "potentially endangered human species" must be carefully considered, and every effort must be made to assure comprehensive information exchange (s) and reach mutual understanding(s) which results in achieving the best interests of all parties, especially CRWA's founding Member Entities.

**CANYON REGIONAL WATER SUPPLY STUDY  
INSTITUTIONAL AND LEGAL ISSUES**

Canyon Regional Water Authority presently recognizes that multiple institutional and legal constraints and challenges facing it as it implements the Regional Plan. The principal challenge is that of having the vision, using its expertise, and establishing the financial underpinnings - - all based on customer support necessary for achieving its balanced development objectives. The common goal is to assure reasonably-priced wholesale water, delivered in dependable quantities and maintaining excellent quality based on current and projected consumer and regulatory requirements and best available technology.

## 9.0 CONCLUSIONS AND RECOMMENDATIONS

A variety of future water supply and development options for the CRWA, and its member WSCs, were developed and evaluated. Initially twenty-three feasible supply options were identified and subjected to a preliminary screening analysis. Five options were selected for rigorous estimation of implementation feasibility and cost. The conclusions drawn from this study and recommended supply Development options are listed in this section.

### 9.1 Conclusions

#### 9.1.1 Future Demands

- The CRWA member WSCs are projected to serve an aggregate population in excess of 65,000 persons by the year 2020. Each of the WSCs is expected to serve populations in excess of 17,000 persons within their existing respective service areas (Figure 9-1).
- Using the TWDB High Per Capita Use Series Projections With Water Conservation, the aggregate CRWA water supply demand in the year 2020 is approximately 11,400 AF/yr (10.0 MGD) (Figure 9-2).
- Individually, GVVWSC will require a total of 3,608 AF/yr (3.22 MGD); SHWSC will require a total of 2,747 AF/yr (2.45 MGD); CCWSC will require a total of 2,465 AF/yr (2.20 MGD) and ECWSC will require a total of 2,585 AF/yr (2.31 MGD) to meet the projected demands ( also Figure 9-2).
- The amount of additional supplies necessary to satisfy the projected demand is the difference between the projected demand and firm supplies from current sources that can be counted on through the 1990-2020 planning period.

#### 9.1.2 Future Supplies

##### Quantities

- All CRWA members derive all or part of their current water supplies either directly or indirectly from the Edwards Aquifer.
- Under the recently adopted EUWD Drought Management Plan, the firmness of the Edwards Aquifer as a future CRWA supply source is cast into serious doubt. Implementation of Phase I Drought Management demand reduction measures in March 1990 and the apparently inevitable implementation of Phase II management strategies in the summer 1990 underscore the undependable nature of the Edwards Aquifer as a primary future CRWA supply source.

Figure 9-1  
Projected CRWA Member Future Populations  
High Series

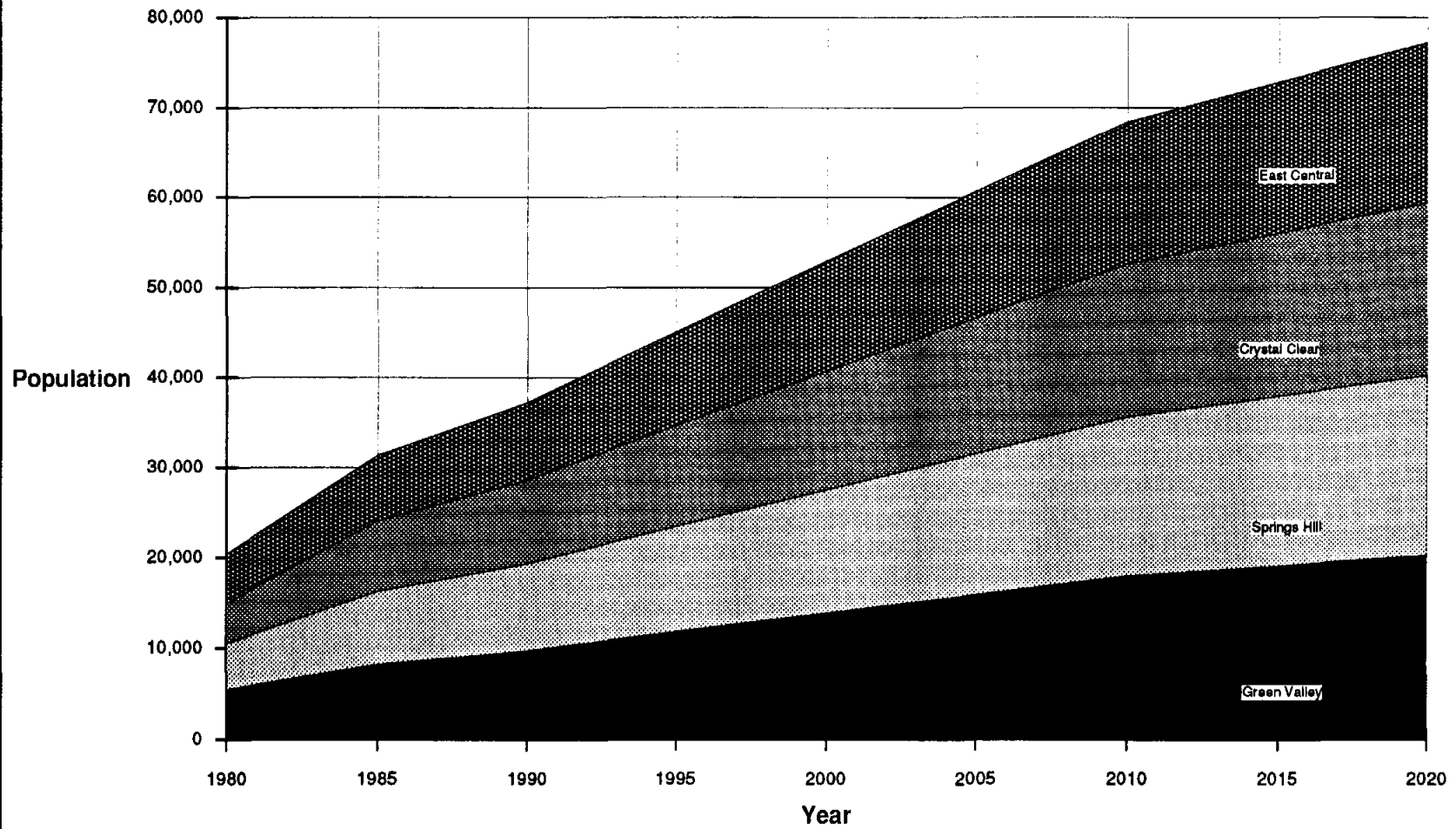
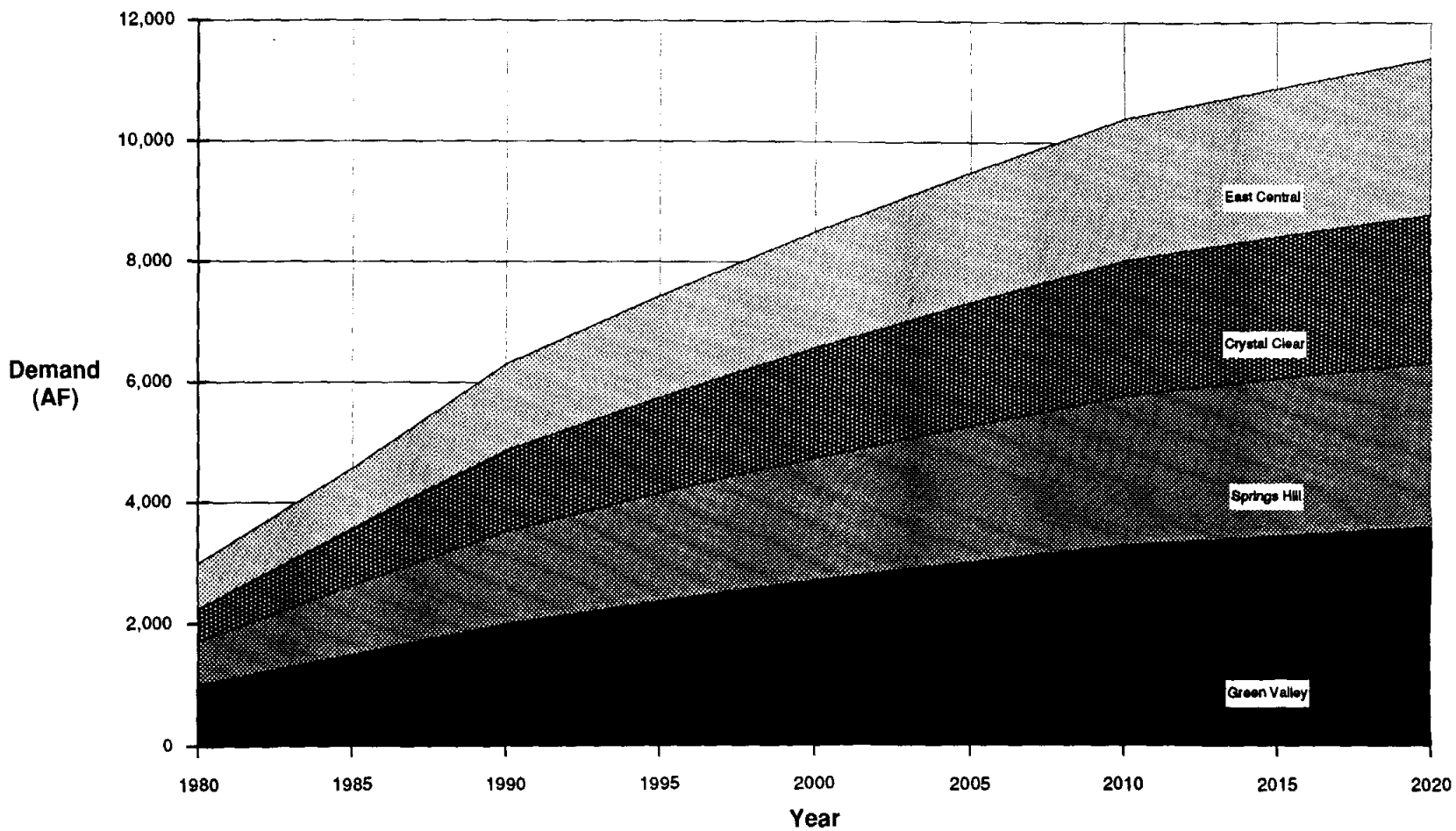



Figure 9-2  
Projected CRWA Member Future Water Demand  
High Population Series - High Per Capita Use - With Conservation



CANYON REGIONAL WATER SUPPLY STUDY  
RESULTS AND CONCLUSION

- Projected future firm drought condition for the Probable Case Development Scenario supplies overlain on projected future demands are shown in Figures 9-3 and 9-4. CRWA needs 2.0 MGD of additional firm supply source and treatment capacity immediately with 2.0 MGD incremental source and treatment capacity additions 1995, 2000 and 2015 Figure 9-5.
- Individually, Gvwsc will require 2,855 AF/yr (2.53 MGD); SHWSC will require 1,240 AF/yr (1.11 MGD); CCWSC will require 2,465 AF/yr (2.20 MGD) and ECWSC will require 2,590 AF/yr (2.31 MGD) of additional water supplies to ensure protection of drought condition projected demands through 2020.

Sources

- The Edwards Aquifer remains the least expensive water supply source available to CRWA members and should be utilized, to the maximum extent allowed under existing permits, contracts and supply agreements, as a future CRWA water supply source.
- Future use of the Edwards Aquifer will be subject to the conditions of the EUWD Drought Management Plan and could be strongly affected by proposed legislation that would limit the export of Edwards water to areas not located directly over the aquifer. Therefore, continued use of the Edwards Aquifer as a major supply source is feasible; however, the long-term reliability of this option is doubtful.
- The GBRA holds TWC Non-consumptive Use Hydropower Generation Water Rights Permits for five impoundments between Canyon Reservoir and the City of Gonzales. The Special Conditions of those permits result in an approximate 1,300 cfs minimum flow restriction in this stretch of the Guadalupe River; effectively precluding appropriation of Guadalupe River water by CRWA except through a Subordination Agreement with the GBRA.
- There are no other firm surface water sources available for appropriation within or near the CRWA service area that would provide a dependable firm supply without expensive on- or off-channel storage.

**Figure 9-3  
Drought Case Projected CRWA Member Future Water  
Demand and Supplies**

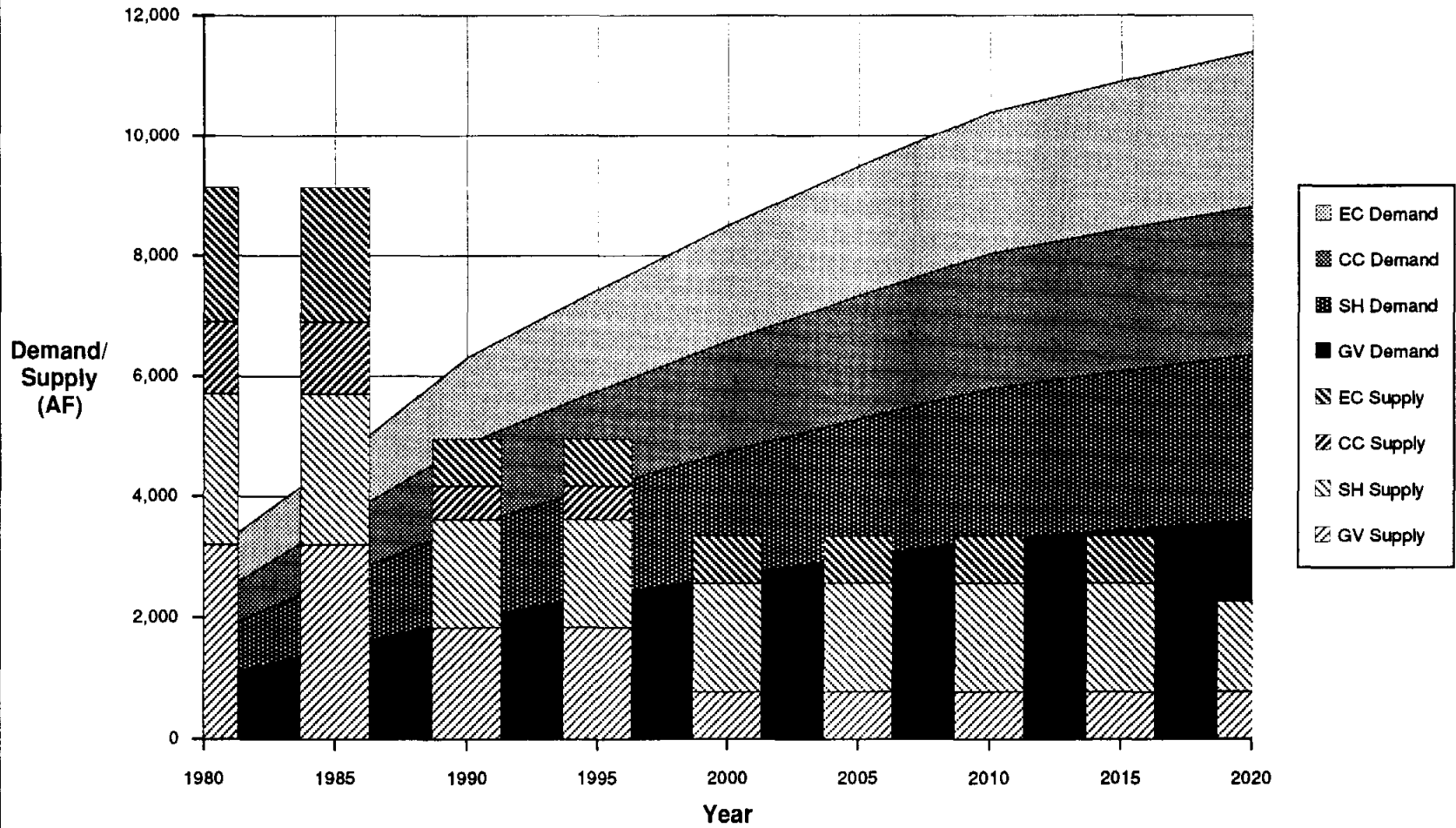

Figure 9-4  
Drought Case Projected CRWA Member Future Water  
Demand and Required Supplemental Supplies

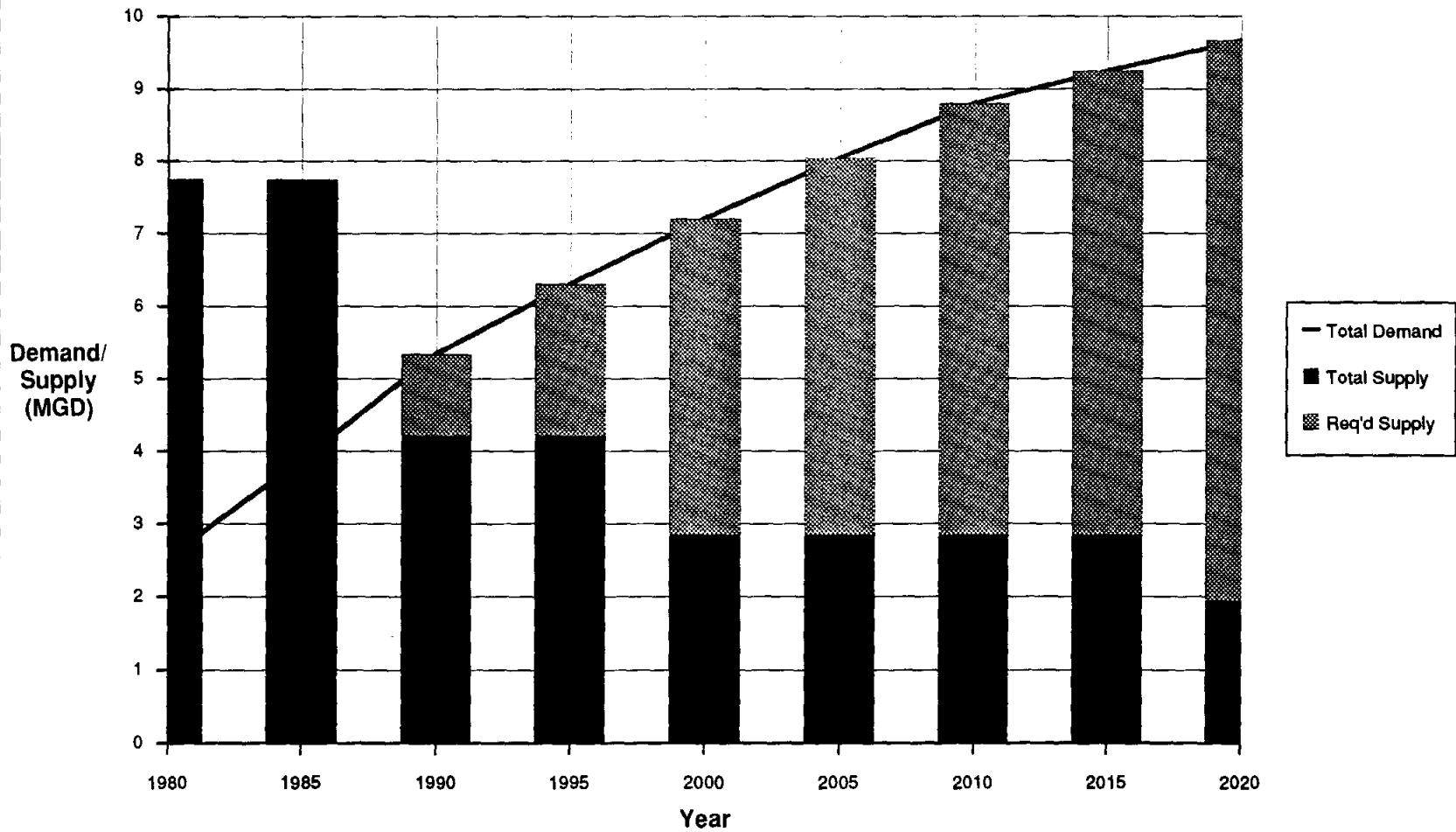
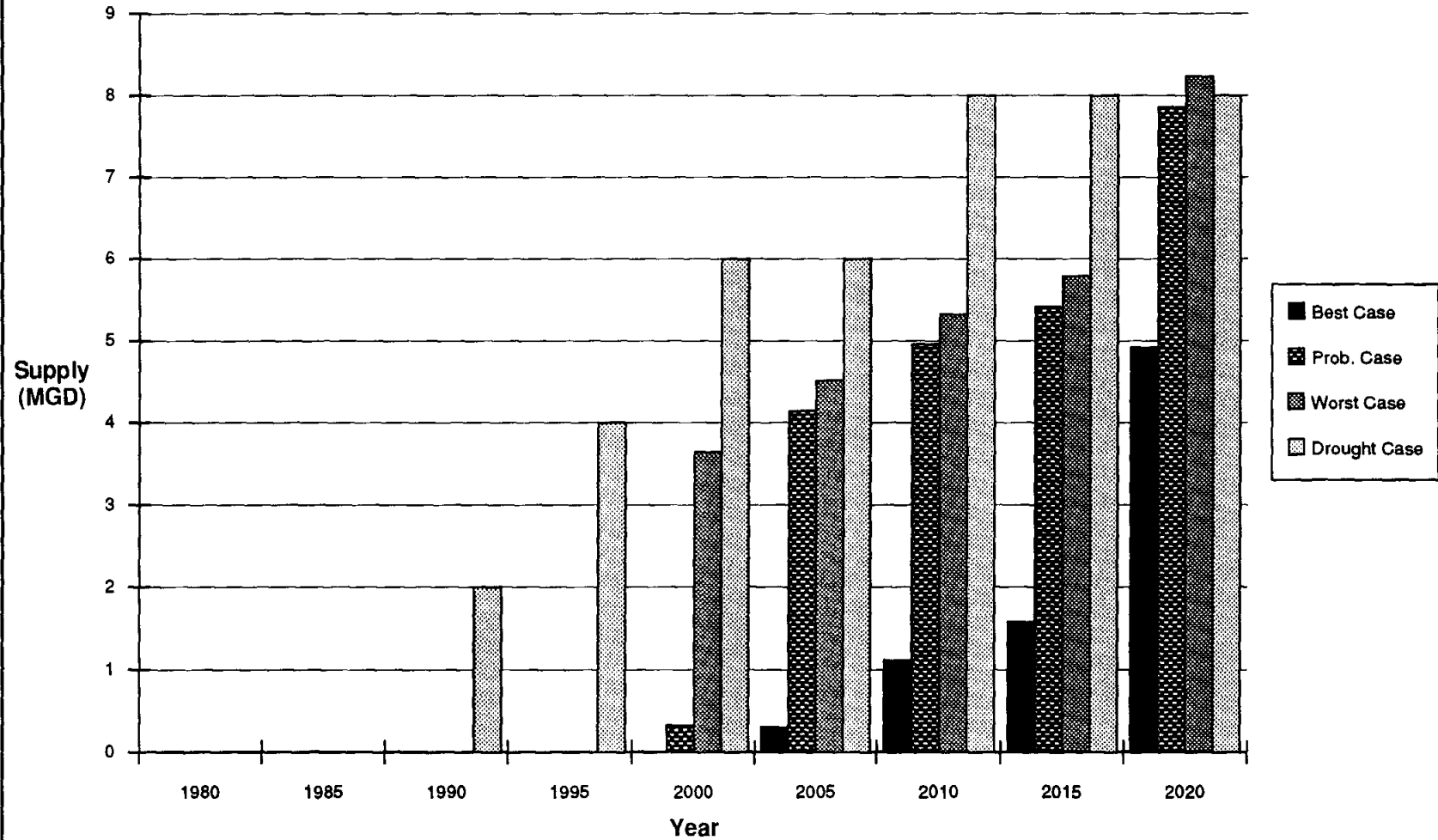

Figure 9-5  
Projected CRWA Member Future Required Supplemental Supplies



- Future supply options such as conversion of coastal basin demands to alternative sources, enhancement of the coastal canal conveyance system, conversion of irrigation rights to municipal rights and recharge of local groundwater formations all either fail to provide sufficient future firm supplies or suffer from major development impediments.
- Local shallow wells fail to provide sufficient future supplies to satisfy projected CRWA demands. During drought periods, these meager deposits would receive little or no recharge and would be quickly depleted.
- The Leona and Carrizo-Wilcox formations both contain groundwater supplies that could serve as future sources to CRWA members. Leona Formation water, however, is known to contain high levels of nitrates which are extremely difficult and expensive to remove. In addition, the Leona Formation would probably prove unreliable during severe drought conditions. Carrizo-Wilcox Formation contains sufficient supplies; however, it also contains elevated levels of iron and manganese which require treatment levels in excess of typical surface water sources.
- Carrizo-Wilcox Formation water should be considered only as a supplemental supply to be blended with other supplies and treated at a surface water treatment facility.
- There are no candidate wastewater sources within or near to the CRWA service area which would provide a cost effective dependable supply for reclamation and reuse.
- Purchase of future supplies from the GBRA and treatment in facilities constructed by either the CRWA or GBRA or use of existing excess capacity of the City of Seguin treatment facility all appear to be feasible and cost effective future CRWA supply and treatment alternatives (Figure 9-6). Use of excess Seguin treatment capacity, however, would be limited to the present through 2005.

## **9.2 Recommendations**

- CRWA should institute an aggressive water conservation program with the following elements:
  1. Education and Information
  2. Plumbing Codes
  3. Retrofit Program
  4. Water Rate Structure
  5. Universal Metering
  6. Water Conservation Landscaping

Figure 9-6  
Cost/1,000 gal of Major CRWA Supply Options

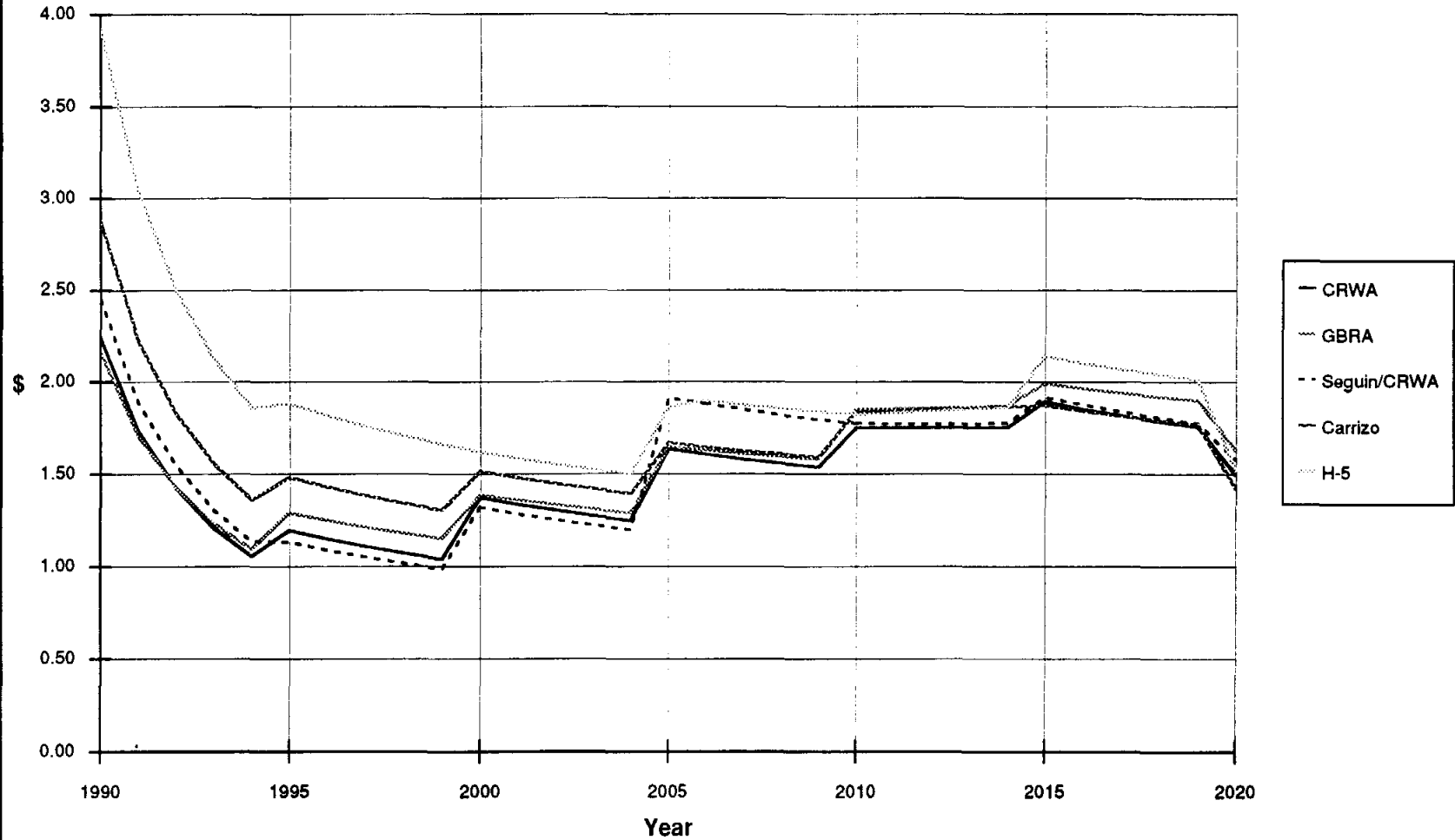

CANYON REGIONAL WATER SUPPLY STUDY  
RESULTS AND CONCLUSION

7. Leak Detection and Repair

8. Recycle and Reuse

- CRWA should approach the EUWD to ascertain the future of permits which allow transfer of Edwards water off the aquifer. CRWA should request renewals of all existing permits. In addition, CRWA should apply for additional permits sufficient to supply future demands. The outcome of these applications will establish a baseline for development of alternative supplies.
- CRWA should enter negotiations with the GBRA to either:
  1. Purchase 4,500 AF/yr from Canyon Reservoir storage through the year 2000 with an option to purchase an additional 4,500 AF/yr beginning in 2000; and begin immediate construction of a new 2.0 MGD water treatment facility near Lake Dunlap; or
  2. Enter into a contractual agreement whereby the GBRA will supply treated water to CRWA in the incremental amounts and times sufficient to meet projected future drought condition firm supply needs.
- Distribution system construction should be phased to reflect short- and long-term future CRWA development options.
  1. CRWA should begin construction of a short-term future water distribution system that will deliver supplies to all potential customers through the year 2005.
  2. Long-term future distribution system decisions should be deferred until such time as the future demand and distribution scenarios identified in this report are either verified or superseded with updated estimates.
- The short-term CRWA treated water distribution system should resemble that depicted in Figure 9-7.



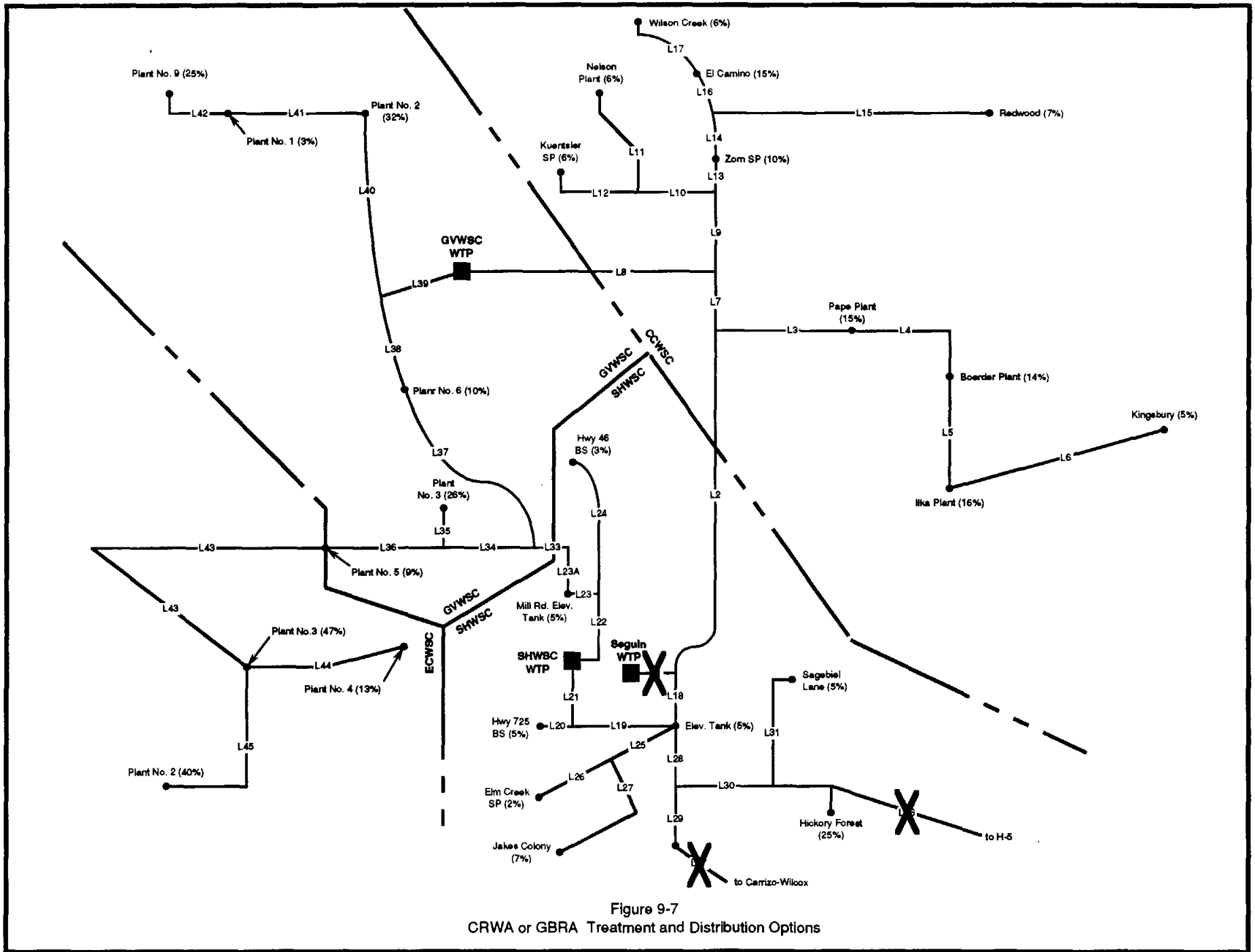

Figure 9-7  
CRWA or GBRA Treatment and Distribution Options