

Georgetown Regional Wastewater Planning Study

- Final Report -

Presented to

City of Georgetown
and
Texas Water Development Board

Presented by

Wallace, Winkler & Rice, Inc.
8225 Central Park Drive, Suite 100
PO. Box 22007
Waco, Texas 76702
(817) 772-9272



In Cooperation with

MSA
1250 Capitol of Texas Highway
Building 3, Suite 501
Austin, Texas 78746
(512) 329-2949

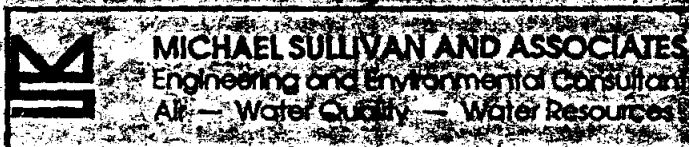

JUN 26 1989

GEORGETOWN REGIONAL WASTEWATER PLANNING STUDY
- FINAL REPORT -

Presented to:
City of Georgetown
and
Texas Water Development Board

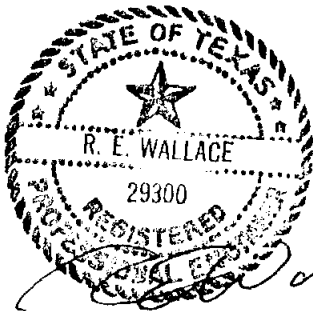

June 16, 1989

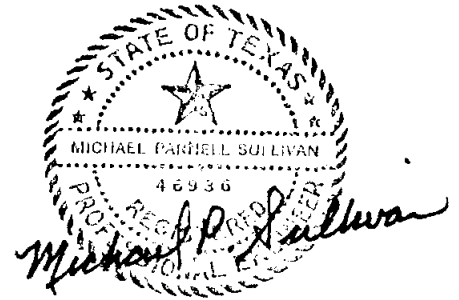

WWR Wallace Winkler and Rice, Inc.
Engineers and Planners
Waco — Temple

In Association With

Michael Sullivan and Associates
Engineers and Environmental Consultants
Austin

ACKNOWLEDGEMENTS

The staff of Wallace Winkler and Rice, Inc. and Michael Sullivan and Associates wish to acknowledge a number of individuals and agencies for their support and cooperation during the performance of this planning study.

The City Council of Georgetown, Texas provided, the financial resources, leadership and direction under which this study was conducted. The Planning Department, in particular Mr. Ed Barry, oversaw the project management which resulted in a timely and exhaustive analysis of all available future development opportunities for the City. A special thanks to former Georgetown Mayor Jim Colbert for his foresight and desire to protect the San Gabriel River and Lake Granger and the environmental integrity of the Georgetown area.

Special thanks to the Texas Water Development Board for their financial and technical support. Dr. Herb Grubb, Mr. Jim Fries and Mr. John Miloy were consistently available and willing to assist during all phases of this study.

This study would not have been possible without the generous contributions of the SCD Development Corporation, Mr. Bobby Stanton, Mr. Jim Coffman, Mr. Max Richter and Bell-Merritt Farms. It is within this type of cooperative private and public effort that genuine regional planning occurs to the benefit of all parties concerned.

Special thanks to the City of Georgetown Utilities Sub-Committee comprised of Mr. Luther Laubach and Mr. Ercel Brashear for their many hours of time, support and guidance during this planning process.

TABLE OF CONTENTS

SECTION	Page
EXECUTIVE SUMMARY	
I. INTRODUCTION	
A. Authorization and Organization	I-1
B. Scope and Objectives of Study	I-1
C. Contents of Report	I-2
II. EXISTING CONDITIONS	
A. Description of Study Area	II-1
1. Geography	II-1
2. Climatology	II-1
3. Hydrology	II-2
B. Land Use Patterns	II-2
1. Historical trends	II-2
2. Planning for Future Growth	II-3
a. Studies by Samuel L. Wyse Associates	II-4
b. The Georgetown Century Plan	II-5
C. Wasteload Collection Systems	II-9
D. Wasteload Treatment Facilities	II-12
1. Georgetown Wastewater Treatment Plant	II-12
2. Wastewater Treatment in the Remainder of the Study Area	II-16
III. POPULATION AND FLOW PROJECTIONS	
A. Subdividing the Study Area	III-1
1. Determining Drainage Area Boundaries	III-1
2. Description of the Drainage Areas	III-3
B. Population Projections	III-5
1. Projecting Total Populations	III-5
2. Projecting Population by Drainage Area	III-5
C. Projecting Wastewater Flows	III-8
IV. IDENTIFICATION OF POTENTIAL TREATMENT PLANT SITES	
A. Preliminary Screening of Potential Sites	IV-1
B. The Selection of Sites for Further Evaluation	IV-1
V. SAN GABRIEL RIVER AND LAKE GRANGER WASTELOAD EVALUATION	
A. Introduction	V-1
1. Hydrology	V-1
2. Water Quality Standards	V-2
3. Wastewater Discharges	V-3
4. Water Quality Conditions	V-3
5. Classification and Rank	V-5
B. QUAL-TX Surface Water Quality Model Simulations	V-5
1. Impact Analysis Overview	V-5

TABLE OF CONTENTS (Continued)

SECTION	Page
2. Model Description and Formulation	V-6
a. General	V-6
b. Segmentation	V-11
c. Hydraulics	V-12
d. Water Quality Kinetics	V-12
e. QUAL-TX Input Requirements	V-14
f. Calibration and Validation	V-15
g. Model Output	V-15
h. Limits of Model	V-15
3. Existing Wasteload Evaluations	V-16
4. QUAL-TX Simulation Alternatives	V-18
5. QUAL-TX Simulation Results	V-36
6. QUAL-TX Simulation Conclusions	V-60
C. Water Quality Simulations - Segment 1247: Lake Granger	V-61
1. Mass Loading Rate Method	V-61
a. Model Description	V-61
b. Simulation Assumptions	V-63
c. Input Data	V-64
d. Eutrophication Potential Calculations	V-65
2. Comparison of Loadings and Chlorophyll-a Concentrations with Those of Other Texas Lakes	V-66
a. Procedures	V-71
b. Computations	V-71
c. Results	V-77
VI ENVIRONMENTAL CONSIDERATIONS	
A. Introduction	VI-1
B. Geology and Groundwater Hydrology of the Georgetown Area	VI-1
1. Introduction	VI-1
a. General Setting	VI-1
b. Purpose	VI-2
c. Methods	VI-2
2. Findings	VI-3
a. Geologic Setting	VI-3
b. Groundwater	VI-5
3. Conclusions	VI-8
C. Biological Resources of the San Gabriel River between Georgetown and Lake Granger	VI-9
1. Introduction	VI-9
2. Regional Setting	VI-9
3. Habitats	VI-10
4. Important Species	VI-10
D. Cultural Resources Along the San Gabriel River	VI-17
1. Introduction	VI-17

TABLE OF CONTENTS (Continued)

SECTION	Page
2. Cultural Setting	VI-19
a. Cultural Background	VI-19
b. Previous Archaeological Research	VI-21
3. Previously Recorded Sites	VI-22
a. Prehistoric Resources	VI-22
b. Historic Resources	VI-30
4. Site Location Patterns	VI-31
5. Recommendations	VI-33
E. References Cited	VI-33
VII. WASTELOAD COLLECTION SYSTEM ALTERNATIVES	
A. Introduction	VII-1
1. Selection of Development Scenarios	VII-1
2. Modification of Existing Georgetown Treatment Plant Operation	VII-1
a. TWC Mandated Effluent Limits	VII-1
b. Compliance Options	VII-2
c. Description of Existing Treatment Process	VII-2
d. Modification of Existing Treatment Process	VII-4
B. Methodology	VII-7
1. Determining Wasteload at each Site	VII-7
a. Service Area Delineation	VII-7
b. Wasteload Projections	VII-12
2. Evaluation and Sizing of Collection Systems	VII-14
a. Gravity Sewers	VII-14
b. Force Mains/Lift Stations	VII-14
c. Sizing of Lines	VII-14
3. Estimating Capital Costs	VII-15
a. Wastewater Treatment Plants	VII-15
b. Collection Systems	VII-17
C. Results	VII-17
1. One Plant Scenario	VII-17
a. Wastewater Treatment Plants	VII-17
b. Wastewater Collection Systems	VII-20
2. Two Plant Scenario	VII-27
a. Wastewater Treatment Plants	VII-27
b. Wastewater Collection Systems	VII-36
3. Three Plant Scenario	VII-39
a. Wastewater Treatment Plants	VII-39
b. Wastewater Collection Systems	VII-46

TABLE OF CONTENTS (Continued)

SECTION	Page
4. Four Plant Scenario	VII-50
a. Wastewater Treatment Plants	VII-50
b. Wastewater Collection Systems	VII-50
5. Two-Stage Scenario	VII-58
a. Wastewater Treatment Plants	VII-58
b. Wastewater Collection Systems	VII-68
6. Comparison of Cost Estimates	VII-68
VIII. OVERALL EVALUATION AND RECOMMENDATIONS	
A. Evaluation of Alternative Scenarios	VIII-1
1. Water Quality Constraints	VIII-1
2. Environmental Considerations	VIII-3
3. Economic Considerations	VIII-3
B. Recommendations	VIII-6
IX. INSTITUTIONAL CONSIDERATIONS AND FINANCIAL PLAN	
A. Institutional Considerations	IX-1
B. Financial Plan	IX-2
X. WATER CONSERVATION AND DROUGHT CONTINGENCY PLANNING	
A. Introduction	X-1
1. Planning Area and Project	X-1
2. Utility Evaluation Data	X-1
3. Need for and Goals of Program	X-2
B. Long-term Water Conservation	X-4
1. Plan Elements	X-4
a. Education and Information	X-6
b. Plumbing Codes	X-7
c. Retrofit Program	X-7
d. Water Rate Structure	X-9
e. Universal Metering	X-9
f. Water Conservation Landscaping	X-9
g. Leak Detection and Repair	X-10
h. Recycle and Reuse	X-10
i. Implementation/Enforcement	X-11
2. Annual Reporting	X-11
3. Contracts with Other Political Subdivisions	X-11

LIST OF TABLES

TABLE	Page
II.1 Major Developments Using On-site Disposal Systems	II-17
III.1 Georgetown Population Projections	III-6
III.2 Population Projections for Each Drainage Area	III-8
III.3 Residential Flow Projections for Each Drainage Area	III-9
III.4 Industrial Flow Projections for Each Drainage Area	III-10
III.5 Total Flow Projections for Each Drainage Area	III-12
IV.1 Potential Candidate Sites Chosen for Initial Screening	IV-3
IV.2 Criteria Used to Evaluate Potential Wastewater Treatment Plant Locations	IV-4
V.1 7-day 2-year Low-flows (7Q2) for Segment 1248	V-1
V.2 Water Quality Criteria of Segments 1247 and 1248	V-2
V.3 Wastewater Loading to Segment 1248 (as used in TWC Wasteload Evaluation)	V-4
V.4 Wastewater Loading to Segment 1248 (current use and projected permit conditions)	V-17
V.5 QUAL-TX San Gabriel River Simulation Scenarios	V-21
V.6 Simulation Scenario A, DO, BOD, and NH ₃ Concentrations	V-37
V.7 Simulation Scenario B1, DO, BOD, and NH ₃ Concentrations	V-39
V.8 Simulation Scenario B2, DO, BOD, and NH ₃ Concentrations	V-41
V.9 Simulation Scenario C1, DO, BOD, and NH ₃ Concentrations	V-43
V.10 Simulation Scenario C2, DO, BOD, and NH ₃ Concentrations	V-46
V.11 Simulation Scenario D1, DO, BOD, and NH ₃ Concentrations	V-48
V.12 Simulation Scenario D2, DO, BOD, and NH ₃ Concentrations	V-50
V.13 Simulation Scenario E, DO, BOD, and NH ₃ Concentrations	V-52
V.14 Simulation Scenario F, DO, BOD, and NH ₃ Concentrations	V-54
V.15 Simulation Scenario G, DO, BOD, and NH ₃ Concentrations	V-56
V.16 Simulation Scenario H, DO, BOD, and NH ₃ Concentrations	V-58
V.17 Permissible Loading Levels for Total Nitrogen and Total Phosphorus	V-62
V.18 Trophic State Indicators of Lake Granger	V-67
V.19 Texas Lake Data	V-68
V.20 Texas Lake Data Sorted for Phosphorus	V-69
V.21 Texas Lake Data Sorted for Chlorophyll-a	V-70
V.22 Linear Regression Results for Phosphorus and Nitrogen Concentrations	V-74
VI.1 General Stratigraphic Section - Georgetown Area	VI-4
VI.2 Fish Species Collected at Station 1 and 4	VI-14
VI.3 Rare or Endangered Species of Known or Possible Occurrence in Williamson County	VI-15
VII.1 Comparison of Georgetown WWTP with TWC Design Criteria	VII-6
VII.2 Wastewater Flow Projections for the One Plant Scenario	VII-13
VII.3 Wastewater Flow Projections for the One Plant Scenario With 15% Conservation	VII-18
VII.4 Estimated Cost of a Single WWTP at Mankin's Crossing	VII-23

LIST OF TABLES (Continued)

TABLE	Page
VII.5 Flows Used to Determine Pipe Sizing in the One Plant Scenario	VII-26
VII.6 Wastewater Flow Projections for Each WWTP in the Two Plant Scenario	VII-30
VII.7 Wastewater Flow Projections for the Two Plant Scenario With 15% Conservation	VII-31
VII.8 Estimated Cost of WWTPs in the Two Plant Scenario	VII-33
VII.9 Estimated Cost of WWTPs in the Two Plant Scenario With 15% Conservation	VII-34
VII.10 Flows Used to Determine Pipe Sizing in the Two Plant Scenario	VII-38
VII.11 Wastewater Flow Projections for Each WWTP in the Three Plant Scenario	VII-40
VII.12 Wastewater Flow Projections for the Three Plant Scenario With 15% Conservation	VII-41
VII.13 Estimated Cost of WWTPs in the Three Plant Scenario	VII-44
VII.14 Estimated Cost of WWTPs in the Three Plant Scenario With 15% Conservation	VII-45
VII.15 Flows Used to Determine Pipe Sizing in the Three Plant Scenario	VII-49
VII.16 Wastewater Flow Projections for Each WWTP in the Four Plant Scenario	VII-51
VII.17 Wastewater Flow Projections for the Four Plant Scenario With 15% Conservation	VII-52
VII.18 Estimated Cost of WWTPs in the Four Plant Scenario	VII-55
VII.19 Estimated Cost of WWTPs in the Four Plant Scenario With 15% Conservation	VII-56
VII.20 Flows Used to Determine Pipe Sizing in the Four Plant Scenario	VII-60
VII.21 Wastewater Flow Projections for Each WWTP in the Two-Stage Scenario	VII-61
VII.22 Wastewater Flow Projections for the Two Stage Scenario With 15% Conservation	VII-62
VII.23 Estimated Cost of WWTPs in the Two Stage Scenario	VII-66
VII.24 Estimated Cost of WWTPs in the Two Stage Scenario With 15% Conservation	VII-67
VII.25 Capital Costs for Collection Systems	VII-71
IX.1 Current Wastewater Rates	IX-3
IX.2 Cost Requirement Analysis	IX-5
IX.3 Rate Requirement Analysis	IX-5
X.1 Expected Savings Through Implementation of a Water Use Retrofit Program	X-8

LIST OF FIGURES

FIGURE	Page
II.1 Georgetown Century Plan Area with TWDB Planning Area and MUDs 5 and 6	II-7
II.2 City of Georgetown Existing Wastewater Collection System	II-10
II.3 Flow vs Discharge of Existing Georgetown WWTP, 1985	II-13
II.4 Flow vs Discharge of Existing Georgetown WWTP, 1986	II-14
II.5 Flow vs Discharge of Existing Georgetown WWTP, 1987	II-15
II.6 Conventional Subsurface Disposal System	II-17
II.7 Major Developments Using On-site Disposal Systems	II-19
III.1 TWDB Planning Area with Drainage Areas	III-2
III.2 Distribution of Existing and Projected Population by Drainage Area	III-7
III.3 Land Use Intensity Map	III-11
IV.1 Potential Candidate Sites Chosen for Initial Screening	IV-2
V.1 QUAL-TX Segmentation Used for Simulations	V-7
V.2 Location of Permitted Facilities and Pending Applications	V-9
V.3 QUAL-TX Simulation Segmentation - Scenario A	V-22
V.4 QUAL-TX Simulation Segmentation - Scenario B	V-24
V.5 QUAL-TX Simulation Segmentation - Scenario C	V-26
V.6 QUAL-TX Simulation Segmentation - Scenario D	V-28
V.7 QUAL-TX Simulation Segmentation - Scenario E and F	V-30
V.8 QUAL-TX Simulation Segmentation - Scenario G	V-32
V.9 QUAL-TX Simulation Segmentation - Scenario H	V-34
V.10 Segment 1248, DO Concentrations - Scenario A	V-38
V.11 Segment 1248, DO Concentrations - Scenario B1	V-40
V.12 Segment 1248, DO Concentrations - Scenario B2	V-42
V.13 Segment 1248, DO Concentrations - Scenario C1	V-44
V.14 Segment 1248, DO Concentrations - Scenario C2	V-47
V.15 Segment 1248, DO Concentrations - Scenario D1	V-49
V.16 Segment 1248, DO Concentrations - Scenario D2	V-51
V.17 Segment 1248, DO Concentrations - Scenario E	V-53
V.18 Segment 1248, DO Concentrations - Scenario F	V-55
V.19 Segment 1248, DO Concentrations - Scenario G	V-57
V.20 Segment 1248, DO Concentrations - Scenario H	V-59
V.21 Vollenweider's Phosphorus Loading Plot Revised to Include the Effects of Flushing on Trophic State	V-62
V.22 Chlorophyll-a Concentration as a Function of Total Phosphorus and Total Inorganic Nitrogen (all data included)	V-72
V.23 Chlorophyll-a Concentration as a Function of Total Phosphorus and Total Inorganic Nitrogen (outliers removed)	V-73

LIST OF FIGURES (Continued)

FIGURE	Page
V.24 Regression Analysis of Chlorophyll-a Concentration as a Function of Total Inorganic Nitrogen	V-75
V.25 Regression Analysis of Chlorophyll-a Concentration as a Function of Total Phosphorus	V-76
VI.1 Georgetown Century Plan Area with Geological Faults and Eastern Extent of Edwards Recharge Zone	VI-6
VI.2 Wells Providing Potable Water Within the Georgetown Century Plan Area	VI-7
VI.3 San Gabriel River Cross-sections	VI-11
VII.1 Flow Diagram of Existing Georgetown Wastewater Treatment Plant	VII-3
VII.2 Flow Diagram of Modified Existing Georgetown Wastewater Treatment Plant	VII-5
VII.3 Service Area for Each WWTP in the One Plant Scenario	VII-8
VII.4 Service Area for Each WWTP in the Two Plant Scenario	VII-9
VII.5 Service Area for Each WWTP in the Three Plant Scenario	VII-10
VII.6 Service Area for Each WWTP in the Four Plant Scenario	VII-11
VII.7 Capital Costs for WWTPs at Different Levels of Treatment	VII-16
VII.8 Wastewater Flow Projections With and Without Water Conservation	VII-19
VII.9 Possible Capacity Build-out for the One Plant Scenario	VII-21
VII.10 Possible Capacity Build-out for the One Plant Scenario with 15% Conservation	VII-22
VII.11 Cumulative WWTP Costs for the One Plant Scenario	VII-24
VII.12 Layout of Collection System for the One Plant Scenario	VII-25
VII.13 Possible Capacity Build-out for the Two Plant Scenario	VII-29
VII.14 Possible Capacity Build-out for the Two Plant Scenario with 15% Conservation	VII-32
VII.15 Cumulative WWTP Costs for the Two Plant Scenario	VII-35
VII.16 Layout of Collection System for the Two Plant Scenario	VII-37
VII.17 Possible Capacity Build-out for the Three Plant Scenario	VII-42
VII.18 Possible Capacity Build-out for the Three Plant Scenario with 15% Conservation	VII-43
VII.19 Cumulative WWTP Costs for the Three Plant Scenario	VII-47
VII.20 Layout of Collection System for the Three Plant Scenario	VII-48
VII.21 Possible Capacity Build-out for the Four Plant Scenario	VII-53
VII.22 Possible Capacity Build-out for the Four Plant Scenario with 15% Conservation	VII-54
VII.23 Cumulative WWTP Costs for the Four Plant Scenario	VII-57
VII.24 Layout of Collection System for the Four Plant Scenario	VII-59
VII.25 Possible Capacity Build-out for the Two Stage Scenario	VII-64
VII.26 Possible Capacity Build-out for the Two Stage Scenario with 15% Conservation	VII-65
VII.27 Cumulative WWTP Costs for the Two Stage Scenario	VII-69
VII.28 Cost of Treatment Capacity - Comparison of Scenarios	VII-70
VII.29 Total Cost of Collection System - Comparison of Scenarios	VII-72
VIII.1 Total Cost of Collection and Treatment With and Without Conservation	VIII-5
X.1 Wastewater Flow Projections With and Without a Water Conservation Program	X-5

EXECUTIVE SUMMARY

A variety of locations were evaluated as potential sites for additional wastewater treatment facilities in the Georgetown Regional Planning Study. Initially, fifteen potential sites were considered, and of these four were selected for further consideration. The four sites chosen for analysis were:

- The City of Georgetown wastewater facility located along the San Gabriel River just downstream of the park road bridge;
- Dove Springs Development Corporation located along an unnamed fork of Mankin's Branch Creek in the vicinity of CR 102;
- Mankin's Crossing at the San Gabriel River between State Highway 29 and the Mankin's Branch Creek confluence; and
- Berry Creek near the confluence of the San Gabriel River and Pecan Branch Creek.

Many factors were taken into account in making the final site recommendations. As with any wastewater treatment facility, the impact of discharges into receiving streams had to be considered, and treatment levels necessary to achieve standards specified by the TWC for Segment 1248 had to be determined. In addition, much of the Georgetown Regional Planning Area is located over the recharge zone of the Edwards Aquifer. This provides a further constraint in planning, because the TWC has prohibited additional discharges into streams overlying the recharge zone of the aquifer.

Other factors that were considered during the course of the study included additional environmental constraints, such as biological considerations or archaeological features, that might influence the ultimate choice of site(s). Finally, the costs associated with scenarios that met the requisite criteria were considered, in order to determine the most economical alternative.

The expected water quality downstream of the outfall of a variety of wastewater treatment plants at various treatment levels was determined. Several scenarios were constructed in order to determine the combination of plants that would give a total treatment capacity of 8 MGD while maintaining water quality levels in the receiving stream above the minimum DO level of 5 mg/L. The following conclusions were drawn from the QUAL-TX modeling of Segment 1248:

- The City of Georgetown could discharge up to approximately 4 MGD from the existing facility with a treatment level upgrade to 10/3/4 and installation of an outfall main in order to discharge effluent beyond the Edwards Aquifer recharge zone. The minimum DO, under summer critical low flow conditions, resulting from this discharge would be 5.2 mg/L. It is not likely that the City of

Georgetown's treatment facility could be expanded beyond 4 MGD without requiring a treatment level of 5/2/5.

- With or without upgrading the City of Georgetown facility, the proposed Dove Springs WWTP could discharge 2.4 MGD at a treatment level of 10/3/4 without violating the main stem of the San Gabriel River (Segment 1248) minimum DO level of 5.0 mg/L under critical summer low flow conditions.
- Without upgrading the Georgetown facility to a treatment level of 10/3/4, the combined discharge of the Dove Springs Development Corporation and Mankin's Crossing facilities at 5.5 MGD (a total segment treatment capacity of 8 MGD) would result in violation of the 5.0 mg/L minimum DO criterion. The minimum predicted DO concentration is 4.3 mg/L.
- With the City of Georgetown facility upgraded to a treatment level of 10/3/4, Dove Springs Development Corporation could discharge up to 2.4 MGD and the Mankin's Crossing facility could discharge up to 3.0 MGD, both at a treatment level of 10/3/4, without violating the state criterion.
- Without upgrading the Georgetown facility to a treatment level of 10/3/4 a combined discharge of Dove Springs Development Corporation, Mankin's Crossing and Berry Creek facilities at 5.5 MGD (a total treatment capacity of 8 MGD) would result in violation of the 5.0 mg/L minimum DO criterion. The minimum predicted DO concentration is 4.3 mg/L.
- With the City of Georgetown facility upgraded to a treatment level of 10/3/4, Dove Springs Development Corporation could discharge up to 1 MGD, a Berry Creek facility up to 2 MGD, and the Mankin's Crossing facility could discharge up to 2.5 MGD, all at a treatment level of 10/3/4, without violating the state criterion. The minimum predicted DO concentration is 5.1 mg/L.
- A 7 MGD facility located at Berry Creek or an 8 MGD facility located at Mankin's Crossing would require a treatment level of 5/2/5 to maintain DO levels above 5 mg/L at summer critical low flow conditions.

Immediately downstream, Lake Granger (Segment 1247) is directly affected by the quality of the effluent discharged into Segment 1248. EPA National Eutrophication Survey data for Texas lakes indicate that Lake Granger is most likely phosphorus limited. This suggests that control of point and nonpoint sources of phosphorus may be important. However, this factor did not affect the choice of future plant locations.

The geological, biological and cultural resources of the area were surveyed in order to determine whether there were any features that would be determinative in choosing the location of the treatment plant(s). The most critical factor in this study was determining the eastern edge of the recharge zone of the

Edwards Aquifer. The geological study was specifically designed to address this point, as well as to determine the location of wells producing potable water from the aquifer. The survey confirms the original assumption that the three new sites chosen for consideration, Berry Creek, Dove Springs and Mankin's Crossing, are not located on the recharge zone of the Edwards Aquifer.

The biological survey, which included sampling at five sites along Segment 1248, indicated that no biological habitats of particular note would be adversely affected by the construction of a WWTP at any of the proposed locations. Several endangered or threatened bird species have been observed in the area, but the immediate vicinity does not appear to be a preferred habitat for any of them.

A survey of cultural resources revealed that the area is rich in archaeological sites. The only extensive excavations have taken place in association with the construction of reservoirs. However, the available information indicates that sites are likely to be prevalent in drainages, particularly at the confluence of streams. Availability of lithic raw materials and proximity to springs increases the probability of such sites. Thus, potential WWTPs may be located on prehistoric sites. These sites are particularly significant and also difficult to identify if buried in alluvial landforms. A complete archaeological survey of any proposed site is recommended, and may be required by the EPA or the TWDB. None of the proposed sites was eliminated based on this brief survey.

Water quality modeling of selected combinations of sites at various treatment levels was used to select the following scenarios for economic evaluation:

- A single, 8.0 MGD facility at Mankin's Crossing with a treatment level of 5/2/5;
- A two plant scenario that maintains the existing treatment plant at 2.5 MGD with an upgraded treatment level of 10/3/4. A large, 5.5 MGD plant would be built at Mankin's Crossing at a treatment level of 10/2/6;
- A three plant scenario with the existing 2.5 MGD treatment plant, a 2.0 MGD plant at Berry Creek and a 3.5 MGD plant at Mankin's Crossing, all at a treatment level of 10/3/4;
- A four plant scenario with a 1.0 MGD plant at Dove Springs. The existing plant is maintained at 2.5 MGD, the Berry Creek plant is built at 2.0 MGD and the Mankin's Crossing plant has a maximum capacity of 2.5 MGD. All plants operate at a treatment level of 10/3/4;
- A two-stage scenario in which the existing plant is maintained at 2.5 MGD and temporary, 1.2 MGD package treatment plants are located at Berry Creek and Dove Springs. When the capacity of

these two plants is exceeded, all of their flows will be diverted to a large, 5.5 MGD plant at Mankin's Crossing.

It is assumed that each of these scenarios meets the TWC criteria for maintaining minimum DO concentrations, as specified by the TWC, for Segment 1248 of the San Gabriel River. Thus, further narrowing down of the alternatives is likely to rely heavily on economic considerations. Cost estimates were derived for each of these scenarios, with and without 15 percent water conservation. The analysis estimated the capital costs of each option in 1990 dollars with a 25 year pay-out period at 10 percent interest. Annual costs were then converted to present (1990) values using a 5 percent annual discount rate.

A comparison of the five scenarios considered shows that the cheapest scenario is a two-stage scenario in which temporary package plants are used to service the majority, but not all, of the service area during an initial ten year period. This scenario has the advantage of deferring the capital cost of a large treatment plant for ten years (15 years with water conservation). In deciding on the second stage of this scenario, the other four scenarios were analyzed for costs.

The most expensive alternative is the one plant scenario. Two factors contribute to the heavy costs associated with this option. First, the existing treatment plant is abandoned, resulting in the immediate construction of an additional 2 MGD of capacity as compared with the other scenarios. The other reason is the fact that water quality modeling shows that the construction of a single, large facility, discharging a total of 8 MGD, would have to have a treatment level of 5/2/5 in order to meet minimum DO concentrations, as specified by the TWC, for Segment 1248 of the San Gabriel River.

Of the remaining three scenarios, cost increases as a function of the number of plants constructed. Thus, the recommended second phase of the two stage scenario is to retain the existing Georgetown plant at 2.5 MGD and to build a large, 5.5 MGD plant at Mankin's Crossing. An additional advantage of the two plant scenario as opposed to scenarios in which additional plants are constructed concerns flexibility. Given the fact that very large growth projections have been used to construct these scenarios, it is likely that there is considerable inaccuracy associated with the growth scenario constructed for each drainage area. Thus, scenarios that allow for large service areas will accommodate a greater degree of flexibility in growth patterns. This will reduce the probability of providing excess capacity at one site, while requiring acceleration of the construction schedule at another.

Based on these considerations, it is recommended that two temporary package plants be constructed in order to accommodate immediate increases in demand and to defer improvements to the existing

Georgetown WWTP. Later, as demand increases, the existing plant would be upgraded to a treatment level of 10/3/4 and the package plants replaced by a larger plant at Mankin's Crossing.

The following development schedule is recommended:

- Immediately converting the existing Georgetown WWTP from a parallel stream process to a single stream, series two-stage process, thereby limiting its capacity to an average daily flow of 1.67 MGD.
- Diverting flows from basins 0 and 3b from the existing plant to a new, 1.2 MGD package plant at Dove Springs. This plant would also serve basins SWID, E and F.
- Constructing a 1.2 MGD temporary package plant at Berry Creek to serve the Berry Creek watershed (basins B, B1 and C) and basin A.
- In 2000 (or when flows to the Dove Springs plant approach plant capacity) replacing this plant with a 2.8 MGD plant at Mankin's Crossing.
- In 2010 (or when the Berry Creek plant approaches full capacity) abandoning this plant and diverting the flows to the Mankin's Crossing plant.
- In 2015 upgrading the existing Georgetown plant to a treatment level of 10/3/4 in order to increase its capacity to 2.5 MGD while complying with the TWC mandate.
- Increasing the capacity of the Mankin's Crossing plant to a total capacity of 5.5 MGD in two phases, in order to extend its life to the end of the planning horizon.
- Implementing a rigorous water conservation plan, in order to defer much of this capital investment for as much as five years.

I INTRODUCTION

I.A Authorization

Because of the projected growth in the Georgetown area, the City of Georgetown and the Town of Weir, together with several private land developers, have agreed to participate in a feasibility study for the development of regional wastewater facilities. This study, financed in part by the Texas Water Development Board (TWDB), was initiated as a result of House Bill 2 and House Joint Resolution 6, passed by the 65th Texas Legislature in 1985, in order to encourage cost-effective regional water and wastewater facility development.

Accordingly, the City of Georgetown contracted with Wallace, Winkler and Rice, Inc. to undertake a study of the adequacy of existing wastewater facilities in the Georgetown area, and to evaluate the nature, timing and costs associated with alternative scenarios for facility improvements required to meet the predicted demand by the year 2030.

I.B Scope and Objectives of Study

The study area considered for the Georgetown Regional Wastewater Planning Study was the area defined by the City of Georgetown as its Century Plan Planning Area plus the recently incorporated Town of Weir. However, much of this area is quite distinct in character from the existing urban development in the immediate Georgetown vicinity, and unlikely to require organized wastewater service during the planning horizon. As a result, a wastewater service area that contained the future urban growth areas described in the Georgetown Century Plan was delineated out of the larger region. It consisted of the Georgetown Extra-territorial Jurisdiction (ETJ) (as of January 1988), the Town of Weir and its associated watersheds, plus three small areas adjacent to the Georgetown ETJ. The area includes the certified service area of the Williamson County MUDs #5 and #6, approximately 1,500 acres of privately owned land and portions of major watersheds that include the San Gabriel River, Berry Creek, Pecan Branch, Smith Branch and Mankin's Branch.

Growth in the Georgetown area has been driven by many of the same factors that have driven growth in Central Texas in general, namely, the overall condition of the State's economy added to its desirable geographic location. The Balcones fault, which parallels IH 35 provides topographical relief to an otherwise predominantly flat terrain. However, the fault line also defines the eastern edge of a limestone plateau (the Edwards) which is underlain by a series of aquifers. These aquifers provide a source of drinking water for the area and are particularly susceptible to contamination from point and non-point sources.

The objective of the study was to determine the adequacy of existing wastewater treatment facilities given population growth projections and the fact that flows being received by the existing treatment plant approach and occasionally exceed the rated plant capacity. Given that additional treatment capacity will be needed, cost estimates were determined for various alternative development scenarios. In developing these scenarios, consideration was paid to the fact that further discharge of effluent to streams overlying the Edwards Aquifer recharge zone is restricted by the Texas Water Commission (TWC).

Protecting the quality of water that recharges the Edwards Aquifer is of primary concern to the TWDB, the TWC and affected cities. This fact has strongly influenced the way that wastewater management can be approached in the Georgetown area. In addition to constraining the amount of treated sewage that can be discharged over the recharge zone, a reduction in the overall number of septic tank systems is also a goal of the TWDB and TWC. Because many of the proposed developments to the west and northwest of Georgetown are located on the recharge zone, finding a means to dispose of wastewater in these areas is critical. This problem has provided an added incentive for regional planning for wastewater management in the Georgetown area.

I.C Contents of Report

This report focuses on the problem of providing adequate wastewater treatment facilities in the Georgetown area, given the following assumptions:

- the existing city wastewater treatment plant is approaching full capacity;
- it is unlikely that additional discharge of treated sewage will be allowed by the TWC at this or any other site located over the Edwards Aquifer recharge zone;
- considerable growth is projected in the Georgetown area, particularly over the Edwards Aquifer recharge zone in areas not currently served by centralized treatment facilities; and
- it is unlikely that major technological advances for on-site systems will reduce the likelihood of aquifer contamination.

The scope of the study includes an assessment of existing wastewater treatment facilities and a determination of future demand for the years 1990, 2000, 2010, 2020 and 2030. These estimates have been derived from a combination of population projection scenarios together with land use intensity predictions. In determining these estimates, an attempt has been made to assign future wastewater flows to specific drainage basins within the study area, in order to locate areas most in need of facility expansion.

Suitable wastewater collection and treatment alternatives have been identified and evaluated relative to these growth areas. Assessments of project costs, environmental constraints, water quality impacts, feasibility and permitting requirements are presented for a variety of alternative scenarios. Recommendations are made for wastewater treatment plant and major collection line locations and sizing, phasing of different projects and potential financing mechanisms. Given the uncertainties associated with growth projections, a major consideration has been maintaining flexibility and allowing for incremental expansion of the various treatment facilities.

Data used in the study have been derived from a variety of sources. The data collection portion of this study relied heavily on previous population projections and land use intensity maps, particularly those included in the Georgetown Century Plan and the 1983 and 1985 studies prepared by Samuel L. Wyse Associates. Computer modeling, using the TWC QUAL-TX Water Quality Simulation Model, was used to determine water quality constraints associated with various plant size and location scenarios. Environmental constraints were determined from existing geological, biological and archaeological data, verified by field investigation. Cost estimates were derived from the known cost of wastewater treatment plant construction, land prices, interceptors costs and the need for pumping stations based on the topography of the area. Throughout the course of the study, several public meetings were held in order to address the concerns of the study participants and affected public entities, as well as private land owners.

The report is organized into ten sections, with the water quality modeling runs included as a appendix. Subsequent sections include:

- A description of existing conditions in the area, including past growth patterns and predicted future trends. Existing wastewater collection and treatment facilities are evaluated, together with plans for future expansion of wastewater services (Section II).
- The methodology used and results obtained for population projections and wastewater flow predictions are given for each drainage basin, with and without aggressive water conservation efforts (Section III).
- A variety of potential wastewater treatment plant sites are evaluated and four sites selected for further evaluation and modeling. The technical, institutional and economic criteria used in making this selection are explained (Section IV).
- Using computer modeling techniques, the water quality of Segment 1248 (the San Gabriel River below Georgetown) and Segment 1247 (Lake Granger) was determined for a variety of scenarios involving various combinations of these four plant sites at various utilization capacities and treat-

ment levels. These data provided additional constraints to be added to the site selection criteria (Section V).

- Three reports that define the environmental constraints associated with additional wastewater treatment facilities are included. Section VI contains geological, biological and archaeological evaluations of the area with particular reference to potential treatment plant sites and the location of interceptor systems.
- Given the projected population/land use distribution and the various environmental and water quality constraints, wasteload collection system alternatives are presented. Major interceptors, minor collectors and pump stations required by each alternative are described and the costs associated with each scenario presented (Section VII).
- Given the technical, environmental, water quality and economic constraints delineated in previous sections, various wasteload collection and treatment system alternatives are evaluated. Recommendations are made about the location of treatment plants and the sizing of interceptors. Cost estimates are included, together with phasing recommendations. An attempt has been made to incorporate some flexibility into the process so that decisions can be made in response to actual growth patterns (Section VIII).
- A financial plan is presented in order to assist the region in raising the funds needed to meet the capital costs associated with these recommendations (Section IX).
- A water conservation plan that could reduce overall wastewater production by as much as 20 percent, if implemented, is presented in Section X.

II EXISTING CONDITIONS

II.A Description of Study Area

II.A.1 Geography

The City of Georgetown is located in Central Texas within the San Gabriel River basin of the Brazos River. To the west is an uplifted limestone plateau, separated by the Balcones escarpment from the more easterly Grand and Blackland Prairies. West of this fault line streams are commonly incised into the limestone strata and provide a source of recharge for the underlying aquifers. East of the fault line the streams meander across wide valleys cut in soft substrates that are generally less porous and permeable. Another characteristic of the escarpment is its destabilizing influence on water-laden air masses originating in the Gulf of Mexico. The escarpment region is the locus of the largest recorded flood-producing storms in the conterminous United States.

The geological features of the area therefore provide both opportunities and constraints for human habitation. The availability of both surface and ground water in the area is probably one of the reasons that evidence of human activity extends back into prehistoric times. However, the vulnerability of the groundwater to contamination, together with the flood-prone nature of the area, does result in some constraints to development activities.

II.A.2 Climatology

The San Gabriel watershed is located in the subtropical region with hot summers and mild winters. Temperatures vary from an average of 9.5°C (49.1°F) in January to 29.3°C (84.7°F) in July. Prevailing winds are southerly throughout most of the year. However, northerly winds can bring sharp drops in temperature during winter months. These cold spells typically last a few days. Precipitation averages 80 centimeters (31.5 inches) of which an insignificant amount falls as snow. Winter precipitation is mainly in the form of light rain, whereas most other rain results from thunderstorms. Although distributed throughout the year, greatest precipitation is experienced in late spring, with a secondary peak occurring in September.

From the perspective of wastewater treatment, it is significant that the months of July and August are typically the warmest and the least precipitous. An inverse relationship exists between riverine water temperature and its ability to recover from waste loading. Also, a given stream configuration tends to exhibit higher average temperatures as the flow is reduced. Therefore, the concurrence of these two climatological conditions greatly increases the recovery period and thus the need for higher treatment levels.

II.A.3 Hydrology

The City of Georgetown is located on Segment 1248 of the San Gabriel River (North Fork) near its confluence with the South Fork. This segment is defined upstream by North San Gabriel Dam, which has controlled its flow since March 1980, and downstream by Lake Granger (Segment 1247). Lake Georgetown, a man-made, 1,300 acre reservoir behind North San Gabriel Dam, provides flood control and water supply for the Georgetown area. The drainage area of Segment 1248 totals 973.4 square kilometers (375.9 square miles) and includes the Middle and South Forks of the San Gabriel, Berry Creek, Pecan Branch, Smith Branch and Mankin's Branch.

Segment 1248 receives much of its flow during spring months, both from surface run-off and from springs in the Edwards Aquifer and associated limestone formations. Notable springs are Berry Springs located 8.1 kilometers (5.0 miles) north of Georgetown on Berry Creek, and Mankin's Branch Springs 9.7 kilometers (6.0 miles) east of Georgetown on Mankin's Branch. In the Circleville vicinity the Wilson Springs contribute flow from the Wolfe City Sands.

The Georgetown area depends on both surface and groundwater for its supply of potable water. Although the Edwards Aquifer is the largest groundwater producer in Texas, it does not supply an unlimited quantity of water. In general the quality is good and only slightly saline. However, during periods of drought real water quality problems exist and both Austin and Georgetown have developed costly water treatment plants. Other sources of groundwater are the Trinity Sands, a much larger formation which yields less water, and the Alluvium Aquifers located along stream beds and recharged by streams.

The Edwards Aquifer is an artesian aquifer lying within compact, impermeable layers of limestone. It is recharged by rainwater returning through surface faults in the Edwards Limestone outcrops and from streamflow entering the outcrop in the stream channels. Water levels in the aquifer are sensitive to recharge and discharge rates; in recent years increased pumping has resulted in the cessation of many springs during drought periods. High infiltration rates result from its rather limited storage capacity and the fact that it is overlain by a very thin unsaturated zone. This makes it susceptible to contamination from surface sources, demonstrated by the increasingly high amounts of bacteria and nitrate nitrogen detected in many wells in the past few years.

II.B. Land Use Patterns

II.B.1 Historical Trends

The San Gabriel River is located in the Grand and Blackland Prairies. Fertile, black clay soils between Georgetown and Circleville support the growth of maize, cotton and corn, as well as livestock rearing. Ini-

tially, the predominant impact on Georgetown's economy was its role as a market center for the surrounding farm areas. In recent years, Georgetown's position as a major agricultural trading center has declined; cash receipts from agricultural products were 14 percent of the total county effective buying income in 1980 and dropped to less than 5 percent by 1985 (Century Plan - Socio-Economic Conditions p. 89). Recent developments have resulted in a diversification and expansion of the region's economic base.

The City's employment base has also been dominated by the service sector. However, between 1980 and 1984 the proportion of jobs in this sector declined from more than one third of the total jobs to less than one quarter. This is a reflection of the rapid expansion of other sectors of the economy, particularly finance, insurance and real estate, and the government sector. Construction and manufacturing continue to make up significant and growing sectors of the economy. Major industries located in Williamson County include electric equipment manufacturing, limestone quarrying, electronic components fabrication, oil field equipment construction and pharmaceutical preparation. Overall the number of jobs available in Georgetown increased from 3,824 in 1980 to 6,494 in 1984 (Century Plan - Socio-Economic Conditions p. 93).

The City of Georgetown and adjacent developed areas combine to form a functioning economic unit of approximately 18,500 people. Georgetown is also part of the Austin Metropolitan Statistical Area (MSA), which includes Austin, Buda, Round Rock, Pflugerville, Leander and Cedar Park, thereby encompassing parts of Hays, Travis and Williamson Counties. Since 1980 an increasing number of Georgetown residents appear to be working outside the City. Thus, the growth of Georgetown is influenced by, but does not directly parallel, the growth of the Austin MSA.

The population of the City of Georgetown has more than doubled since 1970, a slightly lower rate than that of Williamson County, but faster than that of the State as a whole. Between 1980 and 1987 the rate was faster than that of the Austin MSA. Most of this increase can be accounted for by the overall migration into central Texas, which has declined considerably since the economic downturn beginning in 1986. Thus, the growth of Georgetown will be largely dependent upon the state of the regional economy and the job opportunities that are created.

II.B.2 Planning for Future Growth

Because Georgetown has experienced considerable rates of growth over the last few decades, the City has undertaken several studies in order to predict future growth rates and the need for infrastructure. The first comprehensive plan prepared for the City of Georgetown in 1964 was mostly descriptive, and contained few recommendations. A more detailed plan, the 1976 Comprehensive Urban Plan was prepared by Samuel L. Wyse Associates, and contained a greater level of detail, but suffered from a lack of commu-

nity input. In 1979 the City undertook a series of public hearings in each of eight sectors of the City, in order to obtain citizen input on needs, issues and problems. This supplement to the 1976 plan, a Guide to Growth and Development in Georgetown, Texas, focused on immediate problems and provided a guide for decision-making in association with rezoning and subdivision action.

Another plan, produced in 1983 and updated in 1985 by Samuel L. Wyse Associates, included a Development Impact Analysis, a Thoroughfare Plan and a Parks and Recreation Plan. The Development Impact Analysis included a Development Plan which was adopted by the City in February 1986. A more extensive study was undertaken by the City in the subsequent two years, culminating in the Georgetown Century Plan. It was designed to be a comprehensive planning document that took into account all of the socio-economic and physical factors that have an impact on and are affected by growth and development.

II.B.2.a Studies by Samuel L. Wyse Associates

The Development Impact Analysis (1985) was designed to provide an analysis of the impact of the very large number of development proposals received by the City in 1983 and 1984. Data on numbers and types of building permits were analyzed in terms of their potential impacts on population, land use, facilities and the environment. Using 24 Planning Districts, population predictions for each area were made for the year 2005. As compared to previous studies, much more development (up to 40 percent of total future growth) was predicted for the northwest part of town and less in the south. In addition, the number of duplexes and apartments was considerably increased, thereby increasing the density of development. Previous low-density areas along IH 35 between the forks of the San Gabriel River, and far to the east along State Highway 29 were predicted to be potential sites for development, requiring additional extensions of utilities and facilities.

In general, it was felt that drainage divides would have a large impact on the pattern of growth. Also, that the growth of certain areas would be constrained by the availability of utility services, particularly in the west and northwest. The opening of the South Smith Branch toward Rabbit Hill and the Berry Creek drainage area to the north is also dependent upon the provision of sewer services. Growth in the southwest is constrained by the presence of quarry lands; development to the southeast depends upon better vehicular access.

The study also revealed, given the predicted growth pattern, an inadequate amount of commercial, retail and industrial area, and an inadequate amount of public and semi-public lands. Assuming a total population of 35,000 (in 2005), an additional 194 acres of commercial land (400 square feet per person), an additional 26 acres of public and semi-public land (0.12 acres per 100 persons), an additional 137 acres of school land (0.64 acres per 100 persons) and an additional 207 acres of developed park and recreation

space (0.97 acres per 100 persons) were considered necessary. In addition, streets make up 25 percent of developed land and industrial activities were expected to account for 30 percent of the future labor force. Including the quarry, industrial activities were expected to require a total of 1,742 acres, with an additional 10 percent for railroad lines and facilities.

With most of this proposed development in the design and platting stage, it was anticipated that most of the impact would not be felt until 1987. However, assuming all of the development proceeded as planned, the proposed number of dwelling units would far exceed the absorption rates anticipated for the near future.

Recommendations were made concerning land use suitability of each matrix, taking into account access, relationship to residential areas, ease of providing utility services, physical limitations and current uses. The following conclusions were drawn:

- Growth to the east would benefit from accessibility of utility facilities and limited amounts of environmentally-sensitive areas, but would be constrained by major drainage divides.
- The aesthetic qualities of the northwest will result in a doubling of its population, limited mainly by the utility system.
- Large lot residential development is expected to continue to the west and extreme northwest of the City where there is no sewer service.
- Expansion in the southwest will be limited by the quarry property.
- Higher intensity commercial and multi-family uses are expected near the intersections along IH 35, particularly at F.M. 2338, the North Loop near the airport, and F.M. 2243.
- Heavy industrial uses are predicted along the Georgetown Railroad near IH 35 and U.S. Highway 81 in the south; light industrial uses are anticipated near the airport and between IH 35 and U.S. Highway 81 in the north.

II.B.2.b The Georgetown Century Plan

In order for long-term aspects of growth management plans to transcend short-term changes in the socio-political and economic environment, it is necessary for the plan to be officially adopted by the City Council. The cornerstone of this endeavor was laid in April 1986, when the citizens of Georgetown voted to amend the City Charter by adding a provision establishing "... comprehensive planning as a continuous and on-going governmental function ...". This provision created not only the requirement for the process of

comprehensive planning, but also indicated that the results of the process were to be documented through the adoption of a "comprehensive plan," subsequently named the Georgetown Century Plan.

The process began with a significant financial commitment by the City in its fiscal 1986-87 and 1987-88 budgets. A planning area was established (see Figure II.1), covering approximately 156 square miles. The boundaries, established by a combination of geographical and jurisdictional factors, encompassed that area that could reasonably be expected to be included in the Georgetown extra-territorial jurisdiction (ETJ) by the end of the Century Plan period (the year 2010). The south and southwest limits of the planning area generally follow the boundary of the Georgetown Independent School District (GISD) and also coincide with the common ETJ line between Georgetown and Round Rock or Leander, respectively. The eastern limit extends north from the GISD line along County Road 100 until it joins the San Gabriel River just south of Mankin's Branch confluence. The line then follows the San Gabriel River north along the officially adopted line of demarcation between Georgetown and Weir. From FM 972 around to the San Gabriel River the north and west boundaries were established by projecting two arcs each having a 5 mile radius.

The following requirements of the Charter amendment relate directly to the Georgetown Regional Wastewater Planning Study:

- The purpose of the Plan is to: manage the future development, ensure appropriate and beneficial use of natural resources, facilitate the provision of wastewater facilities and services.
- All public and private development should be in conformity with the adopted Plan.
- Each of several Plan elements should be coordinated and internally consistent.

Another contribution made by the Century Plan to this study comes from information contained in the nine Base Study reports published by the City in the first half of 1987. The central topic of each of these reports roughly matches an aspect or "element" of the community identified by the City Charter as being a required portion of the comprehensive plan. Each study was designed to provide an inventory, as well as a broad understanding of existing conditions, past trends and future needs of the community. In this study, particular attention was paid to the Socio-Economic Conditions, Physical Features, Utilities and Land- Use Study reports.

The next phase of the Century Plan to be implemented was the Policy Plan Element, drafted by a seventy five (75) member citizen advisory group using the Base Study as an information base. The Policy Plan delineates the policies, goals and objectives to be achieved by actions of the City relative to thirteen cate-

GEORGETOWN REGIONAL
WASTEWATER PLANNING
STUDY

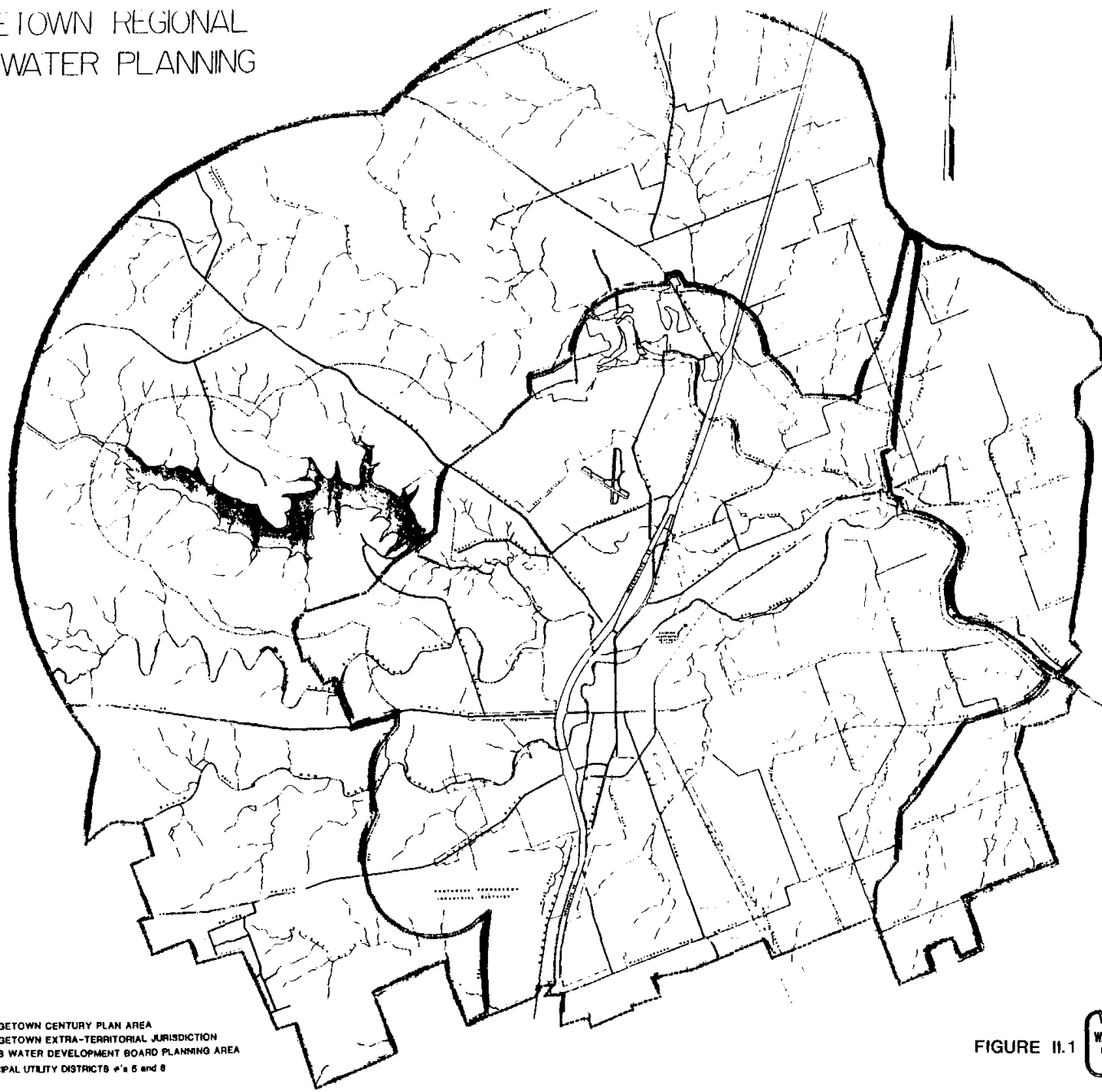

- LEGEND**
- GEORGETOWN CENTURY PLAN AREA
 - - - GEORGETOWN EXTRA-TERRITORIAL JURISDICTION
 - ⊕⊕⊕ TEXAS WATER DEVELOPMENT BOARD PLANNING AREA
 - MUNICIPAL UTILITY DISTRICTS #5 and 8

FIGURE II.1

WWR
WALLACE, WHIKLER & RICE, INC.
ENGINEERS • PLANNERS • SURVEYORS
7429 • TEMPLE

gories that cover the spectrum of subject areas specified in the City Charter. It also discusses at greater length the projected scope, function and guiding principles of the Plan, as well as administrative rules and procedures. Subsequent to a public review and comment period, the Century Plan-Policy Plan element was adopted by the City Council in February 1988. This action established the policy statements and administrative procedures as legally binding guidelines for subsequent City actions for the life of the Plan.

The following statements from the 1988 Policy Plan Summary brochure are directly related to this analysis:

- Develop a water resources system to provide an adequate quantity and quality of water to meet the city's needs;
- Increase the quality of life by upgrading existing and providing new facilities and services;
- Work towards establishing individually self-supporting utility operations;
- Develop a system to aid in the creation of environmentally suitable development projects;
- Establish utility policies which consider the needs of all citizens and take precautions to prevent harmful impacts on the environment;
- The Utilities Functional Plan will encourage and provide for economic development in Georgetown;
- Provide . . . wastewater . . . services to meet the needs of and encourage economic development.

The current phase of the Century Plan activity began in the first quarter of 1988 and is scheduled to continue through April 1989. This phase involves the preparation and adoption of three of the 15 "functional plan elements" discussed in the Policy Plan and derived from the City Charter. This effort is expected to constitute the Land Use, Transportation and Utilities elements of the Century Plan. Since this work is proceeding concurrently with the regional wastewater study and will not be completed prior to the submittal of the final report, its results cannot be fully incorporated into this study. However, some of the preliminary decisions have been utilized to the degree appropriate in formulating recommendations for the expansion of wastewater facilities.

The centerpiece of this current phase of the Century Plan is the development of a computerized system for establishing and monitoring the quantitative relationship between infrastructure demands generated by development (specifically water, wastewater and traffic demands) and the capacity of the infrastructure network to satisfy those demands. The technical aspects of this program are being carried out under contract with a consultant team headed by Richard Verdoorn, Inc. of Austin. A key concept involved in this

system is the allocation of a fixed maximum quantity of the known capacity (both existing and proposed) to each parcel of land in the Georgetown Planning Area. Thus, as long as these maximum limits are not exceeded, the required future demand/capacity for each network will be known.

In an effort to utilize as much of this concurrent planning effort as possible, three preliminary products were incorporated into the wastewater study. The Century Plan - Preliminary Land Use Intensity Map was developed by the City for use in provisional modeling of future infrastructure demands. It has been used in this study to indicate the likely location and land use activity mix of expected future growth. Also used in this study were the Land Use/Infrastructure Equivalency Tables, developed to quantify the demand in gallons of wastewater per acre per day for some 15 types of land use activity in Georgetown. Finally, the initial results of the computer modeling for existing land use wastewater generation were used to help establish the base line from which future demands were projected. Each of these products was used to varying degrees in the distribution and projection of population and wastewater flows and is discussed in more detail in Section III of this report.

II.C Wasteload Collection Systems

The major wastewater collection system within the Georgetown area is that operated by the City of Georgetown. It serves an estimated 15 percent of the total study area. Figure II.2 shows the location and configuration of the existing network of collection lines, manholes, pump stations and the treatment facility.

Previous studies have organized the collection system network into eight major interceptor lines. Interceptors 1-4 serve the older part of the City south and east of the South Fork San Gabriel. Almost all of these lines are over 30 years old and constructed of vitrified clay. Thus, they are nearing the end of expected service life. At one time the majority of this portion of the system flowed by gravity to the treatment plant. However, currently there are two lift stations, the small Scenic Drive and the 15th Street lift stations added during the 1970s and serving Interceptor 3. More recently, Interceptor 3 was separated at IH 35 so that flows generated west of the expressway are now diverted south into Interceptor 0. Also, with the construction of the 3rd Street Lift Station in 1987, flows generated west of Business 35 are now diverted from Interceptor 1 into the reconstructed Interceptor 5.

Interceptor 5 runs from the major lift station located in San Gabriel Park west along the North Fork San Gabriel. Much of this system is vitrified clay pipe and 10-20 years old. Several major modifications were made to this system during 1986-87 including: the replacement of the major trunk line from the park to IH 35; the construction of a new trunk line from IH 35 to Big Country Lift Station and the elimination of that lift station in favor of an inverted syphon; and the replacement of the trunk line upstream to the Little Country

CITY OF GEORGETOWN

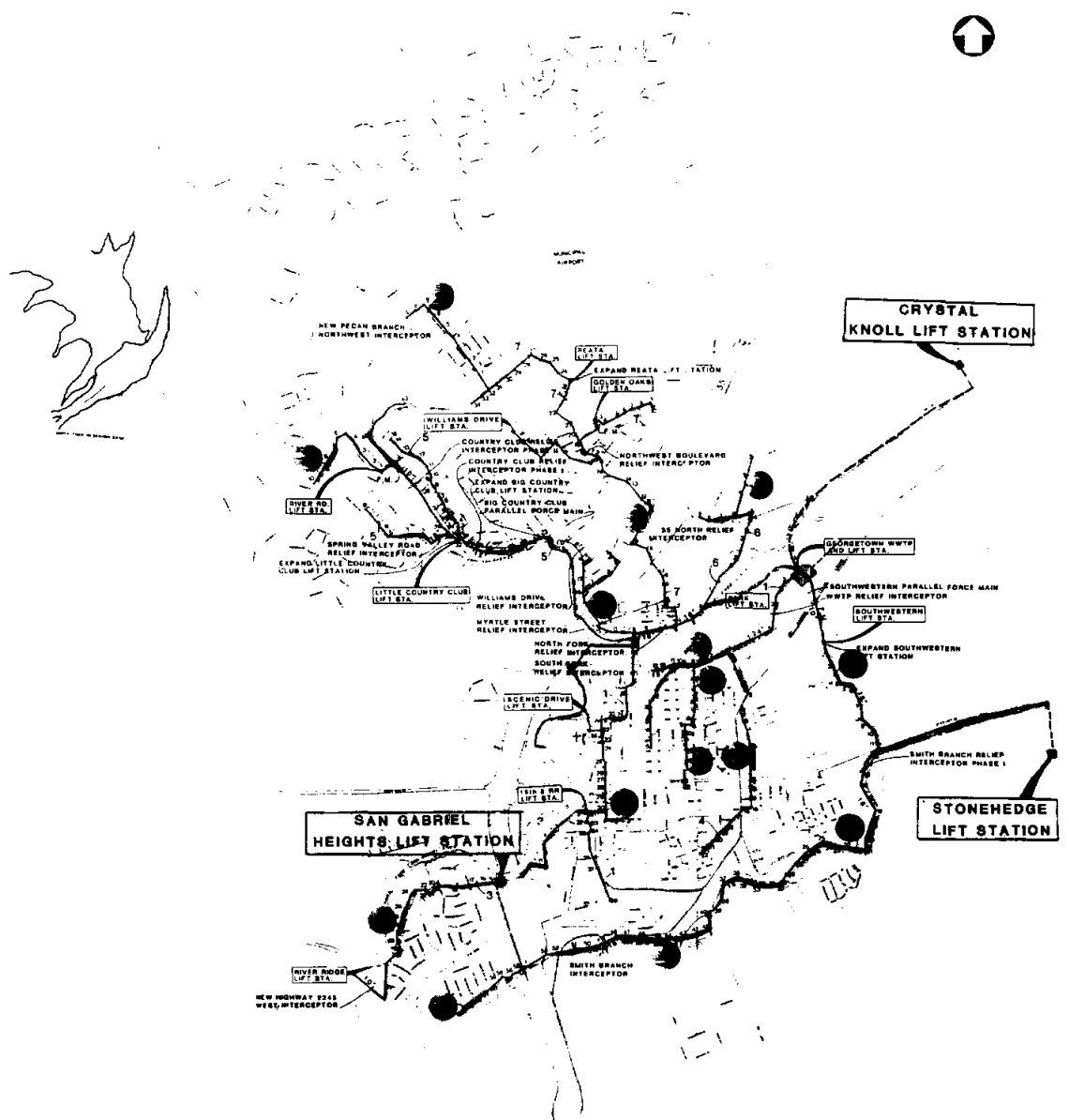

LEGEND

- EXISTING FORCE MAIN
- EXISTING SEWER LINE
- EXISTING LIFT STATION
- EXISTING MANHOLE
- EXISTING WASTEWATER TREATMENT PLANT
- EXISTING CHANGE IN GRADE
- EXISTING CLEANOUT
- MANHOLE IDENTIFICATION NUMBERS
- INTERCEPTOR NUMBER

EXISTING WASTEWATER COLLECTION SYSTEM

WWR
WALLACE, WINKLER & RICE, INC.
 ENGINEERS • PLANNERS • SURVEYORS
 TAOB • TEMPLE

Lift Station. Additional improvements further upstream are still needed to reduce inflow/exflow and provide for future service extension.

Interceptor 6 runs from the Park Lift Station north to Georgetown High School. This network, mostly of PVC pipe, appears to be in good general condition. The likely future service area is quite limited. However, this line could provide service for the septic tank developments existing along Business 35 North.

Interceptor 7 runs from the Park Lift Station northwest to just short of the Serenada area. This system serves all of the land between IH 35 and FM 2338 except for an area immediately surrounding Northside Middle School served by Interceptor 5. It is similar in age and construction to Interceptor 5, but has significantly less line less than ten years old. The natural service area of this system has been tripled by the construction of three lift stations that pump effluent from the Pecan Branch Creek basin. All three of these facilities operate near capacity and some segments of the gravity line along Northwest Blvd. are overloaded. The Reata Lift Station is the largest pumping facility and is scheduled for minor improvements in the Georgetown FY 1988-89 budget. However, this section of the City is likely to remain prime for future development and as this occurs, capacity problems will increase. Previous studies have recommended the elimination of these three lift stations and the construction of a new major interceptor along Pecan Branch Creek. Unless a new treatment facility is located downstream (between IH 35 and the Berry Creek confluence), the wastewater would still need to be pumped into the downtown treatment plant. This could be accomplished by using the partially constructed Crystal Knoll Lift Station and force main located at the intersection of Pecan Branch Creek with C.R. 152.

Interceptor 0 begins at the Southwestern Lift Station located some 2000 feet south of the wastewater treatment plant and runs south and west along Smith Branch Creek to a point west of IH 35. It has served all connections south of State Highway 29 and west of IH 35 since the previously mentioned diversion of Interceptor 3 by completion of the San Gabriel Heights Lift Station. It also serves a rather narrow strip along the southern perimeter of the City from IH 35 to Highway 29 East. The Southwestern Lift Station has been overloaded during peak flow periods for some time. Similarly, the lower one third of the collection line has had capacity problems. This condition is reported to be more a problem of infiltration into the system than of too many connections and is attributed to its construction through unstable clay soils with inadequate bedding. Extensive rehabilitation of this interceptor has been proposed as part of the ongoing wastewater rehabilitation program. Once the needed improvements have been made this line has the potential for serving a very large area south of the City. This area has been designated as being the highest priority new development area by the Century Plan and the extension of water and wastewater services to this area is currently in progress.

In summary, Georgetown has had a centralized wastewater collection system for more than 30 years. Portions of the system are quite old, although there have been frequent additions to it. The collection lines are largely of vitrified clay. About 80 percent of the pipes are clay and 20 percent are plastic. Many of the older sewer lines are in need of maintenance or replacement. Some of the laterals were constructed over insufficient bedding materials in low water table areas, causing the lines to settle. Severe infiltration of the system by surface and groundwater is evident by the significant increases in the amount of water processed by the plant following a good rain. This also results in overflows at several manholes in the collection system. These problems are being addressed through an ongoing sewer rehabilitation program and through the coordination of construction related to new development.

II.D Wastewater Treatment Facilities

II.D.1 Georgetown Wastewater Treatment Plant

Georgetown currently owns and operates one WWTP located south of the San Gabriel River, east of College Street. It was originally built in 1965 and totally rebuilt with new structures and a new treatment process in 1983. It utilizes a contact stabilization process and has a rated capacity of 2.5 MGD. Sewage is received from all parts of the collection system and treated effluent is discharged directly into the San Gabriel River.

The WWTP operates under Texas Permit #10489-Z, and under the National Pollution Discharge Elimination System (NPDES) Permit #Tx0022667 which regulates both the quality and quantity of discharge. Currently, the plant's maximum allowable discharge is 2.5 MGD averaged over a month and the maximum daily discharge is 3.5 MGD, of which up to 1.0 MGD may be discharged via irrigation by Southwestern University and the golf course. The pollutant level is set at 10 milligrams per liter of 5-day biochemical oxygen demand (BOD₅) and 15 milligrams per liter of total suspended solids (TSS). There are currently no requirements for nitrification. Thus, the effluent ammonia (NH₃) concentration is assumed at 15 mg/L.

In 1988 the WWTP was operating at 68 percent of its monthly rated capacity and had never exceeded its permitted daily limit or maximum monthly limit. In 1986 it was cited as one of the ten best in the State by the Texas Water Quality Board. However, there have been several instances when discharge flows have approached the maximum allowable and this has led to speculation that flows could exceed the maximum capacity of the existing plant by 1990. Analysis of self-reporting data for January 1985 through December 1987, indicates that very high flow months correspond to periods of heavy precipitation (Figures II.3 - II.5). Most notably, the last four months of 1986 have discharge flows recorded as 2.27, 2.82, 1.82 and 2.27 MGD as compared to precipitation levels of 4.44, 8.12, 2.49 and 6.53 inches. Similarly, 3.55 MGD discharged in June 1987 is obviously the result of 8.01 inches of precipitation in late May followed by 9.78

Figure II.3
 Flow vs Discharge of Existing Georgetown
 WWTP from 1985 TWC Self-Reporting Data

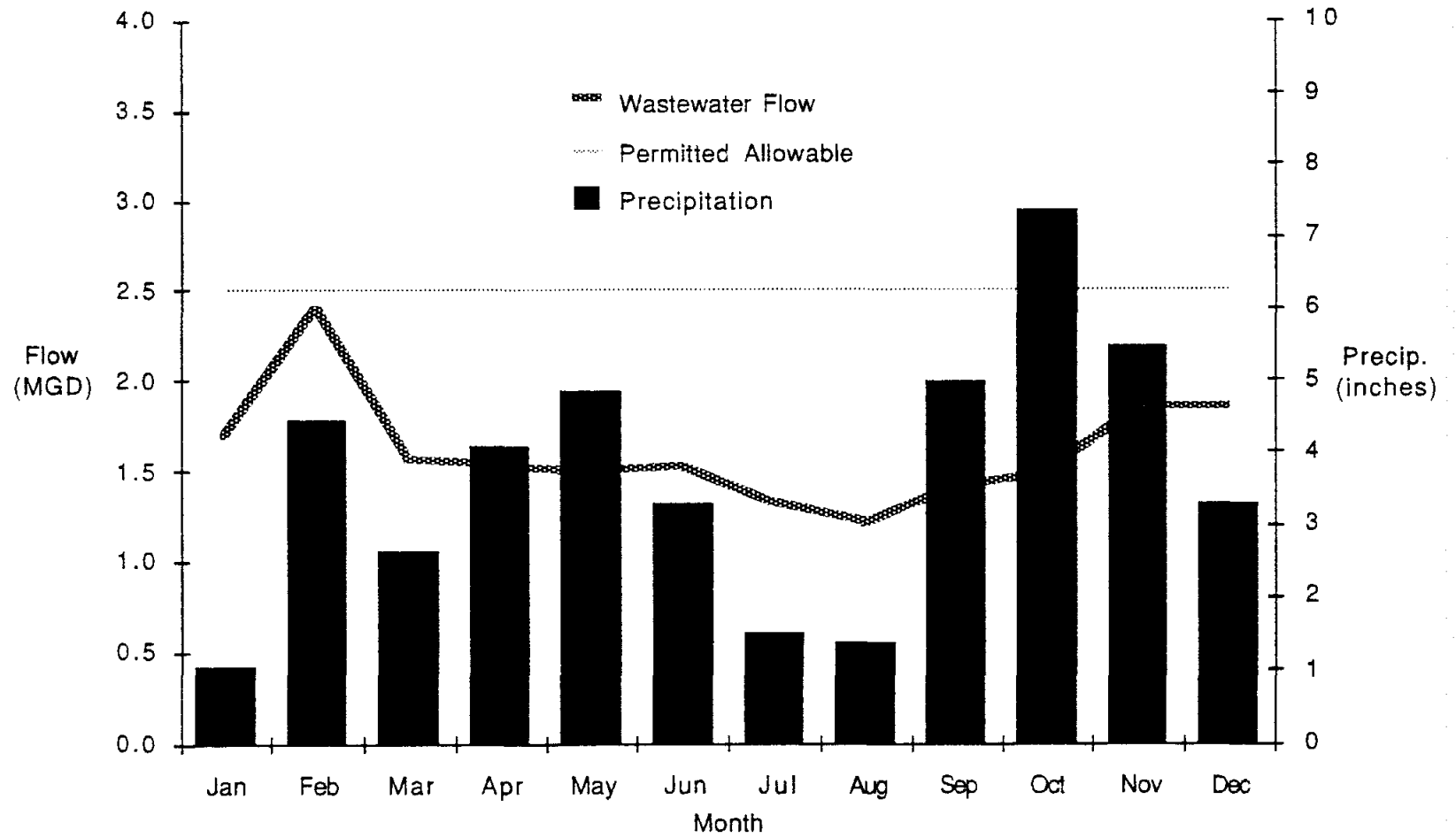

Figure II.4
 Flow vs Discharge of Existing Georgetown
 WWTP from 1986 TWC Self-Reporting Data

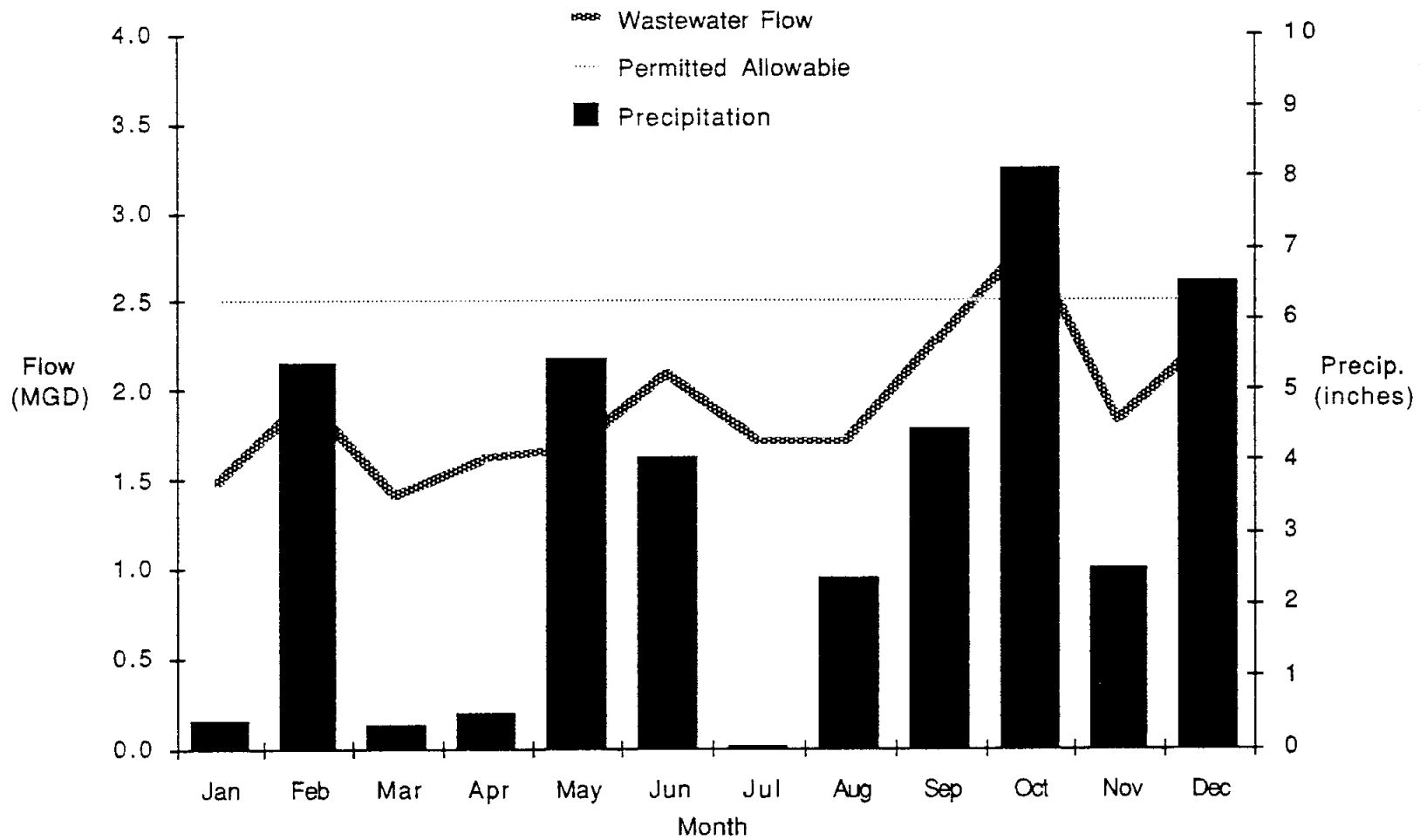
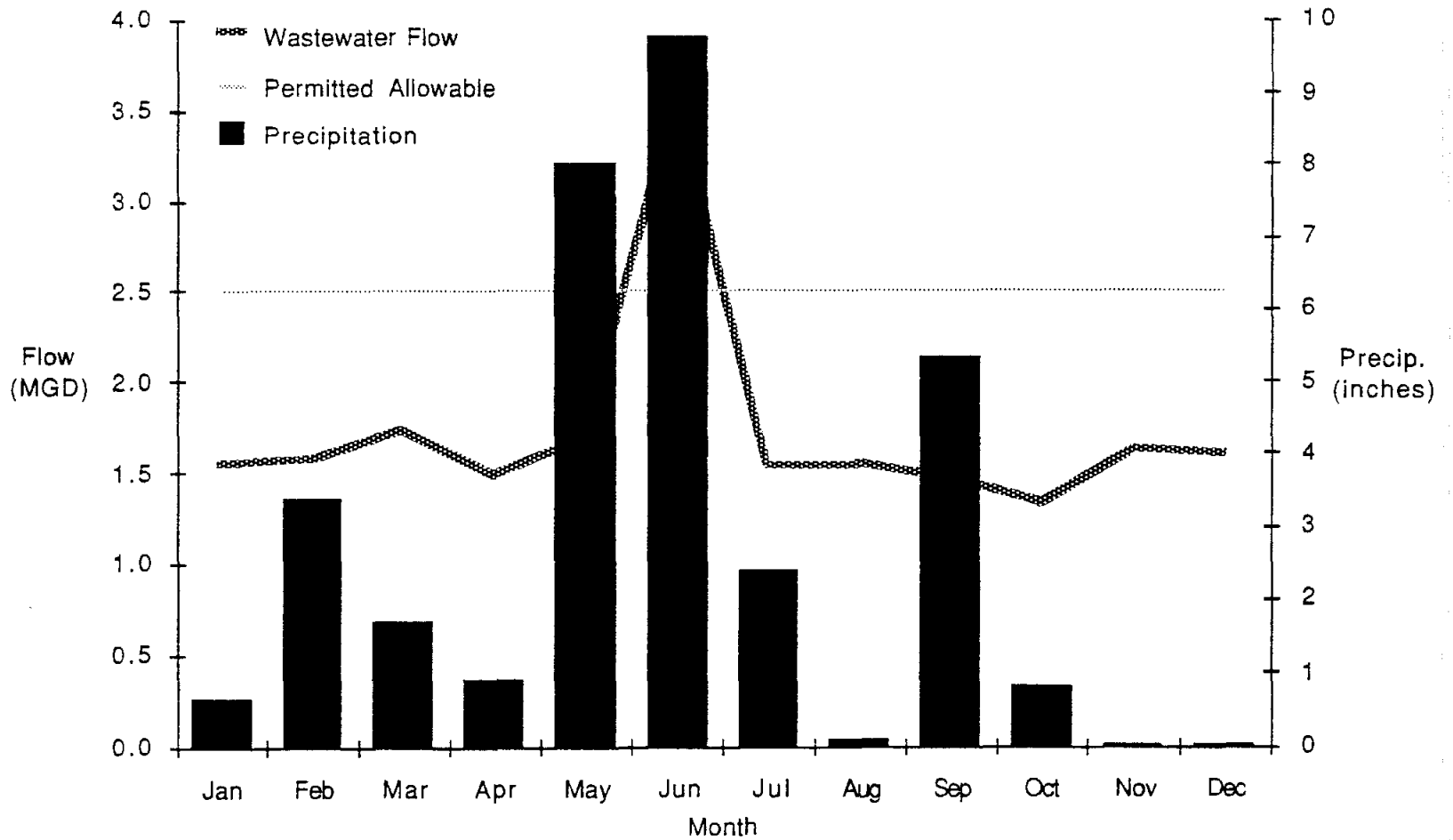

Figure II.5
 Flow vs Discharge of Existing Georgetown
 WWTP from 1987 TWC Self-Reporting Data



II-15

inches in June. Throughout the remainder of 1987, base flows appear to be approximately 1.6 MGD. These data suggest that the City of Georgetown has a inflow/infiltration problem that the City is currently addressing.

II.D.2 Wastewater Treatment in the Remainder of the Study Area

Williamson County MUDs No. 5 and 6 are currently sewered and treated by a 0.4 MGD facility. This facility has a zero discharge permit and disposal of effluent is by spray irrigation. Due to its location on the Edwards Aquifer recharge zone (Figure II.1), it is unlikely that this permit will ever be amended to allow discharge to a surface water course. South and east of the City, the Dove Springs Development Corporation has a permit for a 0.2 MGD facility at a treatment level of 10/15/4, with a proposed new application to the TWC to raise the discharge flow from this facility to 1.2 MGD.

The remainder of the study area relies exclusively on on-site disposal systems, primarily septic tanks utilizing subterranean drain fields to discharge "treated" effluent (see Figure II.6). The installation and operation of these facilities is regulated by the County Health Department under rules promulgated by the Texas Department of Health and the Texas Water Commission. Due largely to substandard installation and maintenance, especially of older units, these systems pose a threat to the water quality of underlying aquifers. This is particularly significant within the recharge zone of the western half of the study area, a preferred growth region. The primary regulation of these systems takes the form of construction standards and minimum lot size requirements for new construction. The minimum lot size for systems over the recharge zone is one acre and for non-recharge areas it is one half acre. The only remedial program in effect is a requirement that failed systems cannot be permitted within 300 feet of an organized collection system with available capacity. Given these requirements, it is obvious that development at normal urban densities can only occur in areas served by organized wastewater collection and treatment facilities.

An accurate inventory of the number and location of on-site systems is beyond the scope of this study. However, the major developments using on-site disposal systems in the Georgetown Regional Wastewater Planning Area are shown in Table II.1 and Figure II.7. Table II.1 lists 2,664 lots, many of which are developed and most are overlying the Edwards Aquifer recharge zone. An estimated 750,000 gallons per day of effluent is discharged from these systems onto the recharge zone.

It is evident that the most significant occurrence of septic tanks is north of State Highway 29 at the edge of or beyond the city limit. The western half of drainage area 1 contains the Oakcrest Ranchettes/Greenridge subdivisions with some 227 residential lots covering 505 acres. Area 3a contains one 32 lot residential subdivision and several scattered commercial and residential lots. Area 5a includes a half-dozen

TYPICAL LAYOUT

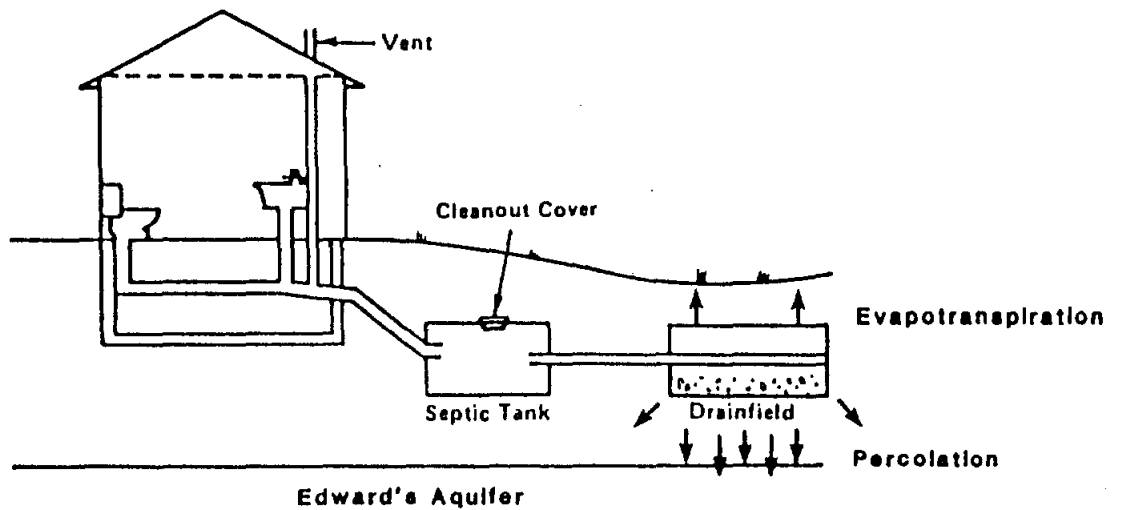

* NOTE: QUANTITY OF WASTEWATER FROM SEPTIC TANK SYSTEMS IS APPROXIMATELY 750,000 G.P.D. ON THE EDWARD'S AQUIFER RECHARGE ZONE

FIGURE II.6

CONVENTIONAL SUBSURFACE DISPOSAL

WWR
 WALLACE, WINKLER & RICE, INC.
 ENGINEERS • PLANNERS • SURVEYORS
 TACO • TEMPLE

**Table II.1
Major Developments Using On-site Disposal Systems**

Drainage	Development Area	Lots	Acres	Remarks
1	Oakcrest Ranchettes/ Greenridge ^{a/}	227	505	
3a	Legend Oaks Legend Oaks II Wolf Tract	49 6 8	30 7 9	Proposed commercial
5a	San Gabriel Estates Oakcrest Estates ^{a/} Turtle Bend Country West	38 93 63 39	88 176 35 41	
5b	River Hills Hwy 29 strip north	70 7	85 57	Residential/commercial
A	Pennington Place Other	38 100	38	Estimate (unplatted parcels)
B	Serenada Estates Andice Strip ^{a/} Georgetown Airport Golden Oaks Industrial Park North Gabriel Estates	547 4 NA 49 47 25	718 15 45 138 20 29	Estimate Commercial
B1	Serenada East Logan Ranch Sanaloma Estates Brangus Ranch ^{b/} Air Country Estates ^{b/} Tonkawan Country Berry Creek Airport Industrial Park	368 82 124 25 26 24 98 6	250 323 53 60 56 52 73 18	
C				Two commercial developments - data not available
D				Two residential developments - data not available
D1	Indian Creek Dove Springs	151 62	88 40	
E	FM 1460 strip Rabbit Hollow Unnamed Subdivision ^{b/} Clearview Estates	59 83 12 20	134 11	
F	IH 35 Strip West ^{b/} IH 35 Strip East ^{b/} McCoy's Subdivision	15 30 7	40 45 13	Commercial
Far South	Advance Custom Molders Plant	2	17	Employs approximately 150 persons
Wood Ranch	Wood Ranch Sections 1-4	60	171	

^{a/} Taken from the Century Plan Data Base (as developed for use in the Century Plan - Land Use Plan Element)

^{b/} Estimated from the Georgetown Zoning Map
Other data taken from Williamson County Plat Records

GEORGETOWN REGIONAL
WASTEWATER PLANNING
STUDY

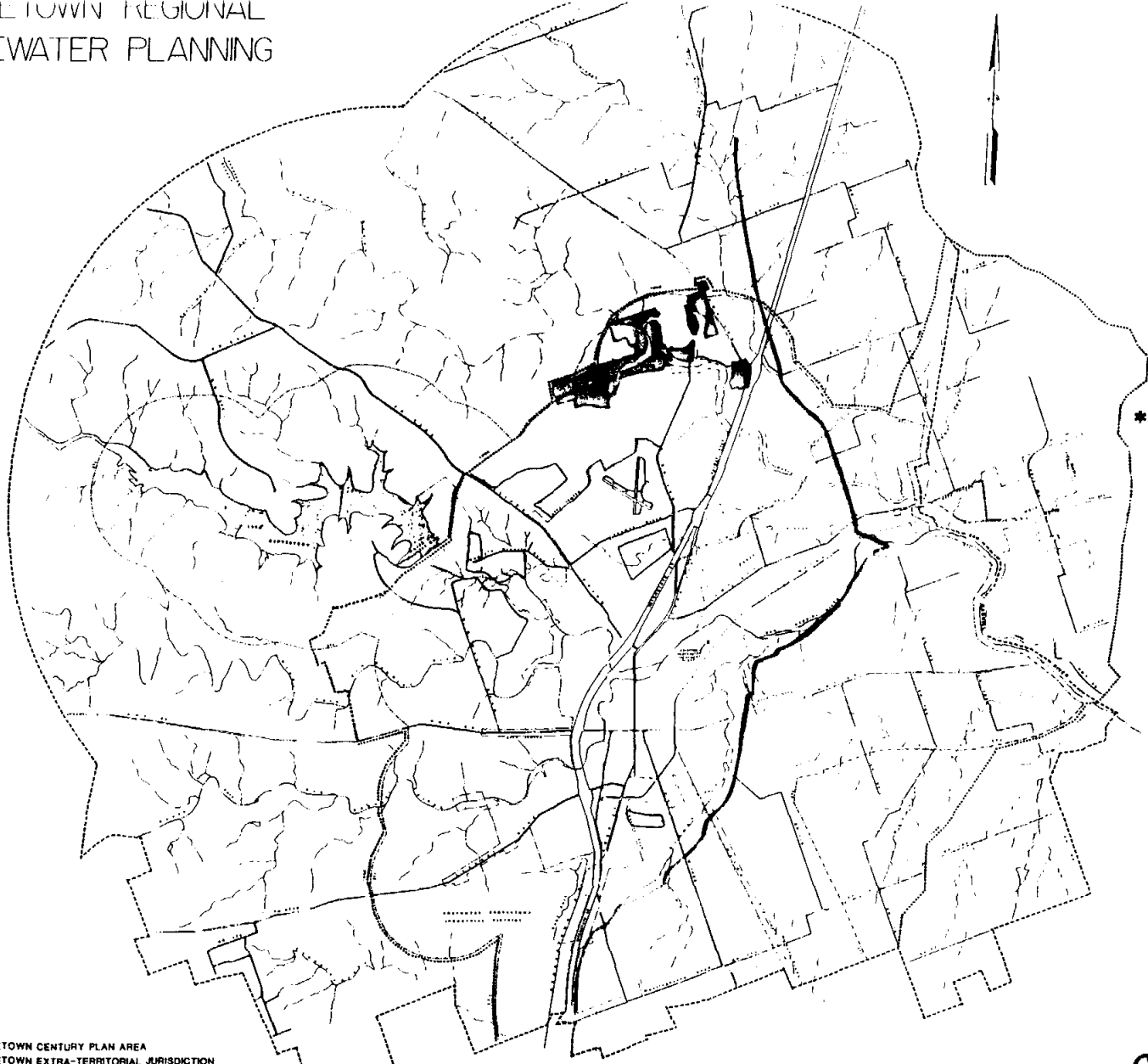

* NOTE: QUANTITY OF WASTEWATER FROM SEPTIC TANK SYSTEMS IS APPROXIMATELY 750,000 GPD ON THE EDWARD'S AQUIFER RECHARGE ZONE

LEGEND

- GEORGETOWN CENTURY PLAN AREA
- GEORGETOWN EXTRA-TERRITORIAL JURISDICTION
- TEXAS WATER DEVELOPMENT BOARD PLANNING AREA
- MUNICIPAL UTILITY DISTRICTS ON SEPTIC TANK SYSTEMS
- AREAS OUTSIDE CITY LIMITS ON SEPTIC TANK SYSTEMS
- EASTERN EXTENT OF EDWARD'S AQUIFER RECHARGE ZONE

MAJOR DEVELOPMENTS USING
ON-SITE DISPOSAL SYSTEMS

FIGURE II.7



subdivisions totaling some 233 lots on 340 acres. Area 5b has 70-80 lots of various uses and plans have been approved by the City to extend service to part of the undeveloped area.

The largest contiguous area developed and/or proposed for development using these systems is that portion of areas B and B1 adjacent to and west of IH 35. This area covers more than 4,000 acres and currently is divided into 1,800 to 2,000, mostly residential, lots. Also included in these two areas is the airport and numerous commercial lots such as Industrial Park North and other developments along Business 35 north of Georgetown High School. A relatively high percentage of these lots, both residential and commercial, have septic systems in place.

Drainage area A east of town has no major consolidated developments but does contain numerous homes on lots smaller than 10 acres. Similarly, all of the population of the Weir area (areas A1, A2, A2a and A3) are served by on-site systems. Other drainage areas, including D1, E, F and Far South, contain scattered, small to medium sized developments located primarily adjacent to major roadways.

III POPULATION AND FLOW PROJECTIONS

Siting of wastewater treatment plants is critical, because, unlike water supply systems, collection systems rely primarily on gravity to transport wastewater. Lines in a wastewater collection network operate most economically when gravity is used to deliver effluent from individual structures to a wastewater treatment plant. Thus, the optimum location of a treatment plant is generally the lowest point in the service area.

In determining the optimum site(s) for wastewater plant(s), the critical determination is to predict where population growth will occur within the area and how the resulting wastewater flows can be gravity fed to a suitable site for treatment. With this in mind, the study area watershed was divided into 23 drainage areas. The primary division lines chosen were the major ridge lines. Within these subbasins, further subdivisions were made based on socio-economic factors and, in some cases, major highways (see Figure III.1).

Population and land use distribution served as the basis for projecting wastewater flows. A variety of data sources were used to predict both total growth within the study area, and how that growth would be distributed. Having assigned residential population to each of the 23 drainage areas for each decade through the 2030 planning horizon, flows were determined using a per capita rate of wastewater production. Flows resulting from anticipated commercial and industrial developments were then added to these estimates to derive the total projected flow for each drainage area.

III.A Subdividing the Study Area

III.A.1 Determining Drainage Area Boundaries

Many of the major streets in the Georgetown area have been constructed along ridge lines. Thus, in this study they often provide an appropriate means of delineating drainage areas, because this increases the extent to which gravity flow can be used to feed major interceptors. Other factors such as the existing collection system and development patterns are then used to refine these major boundaries. For instance, F.M. 2338 was used to define the southern limit of the Berry/Pecan Creek drainage basin west of IH 35. Interstate Highway 35 and State Highway 29 delineate the boundaries of basins 0, 1, 2, 3a, 3b, 5b, A, and D1. Similarly, the Wood Ranch basin is bordered by Wood Road.

Basins are labeled either numerically or alphabetically. The numeric basins represent areas currently served with sewer or additions to major interceptors in adjacent basins. For the numeric basins, consideration was given to a study performed by Richardson-Verdoorn, Inc. designating a boundary, called the urban area. The alphabetically labeled basins represent areas not currently serviced with major interceptors, but rather septic tanks or nothing at all. Three areas that do not conform to these criteria are

GEORGETOWN REGIONAL
WASTEWATER PLANNING
STUDY

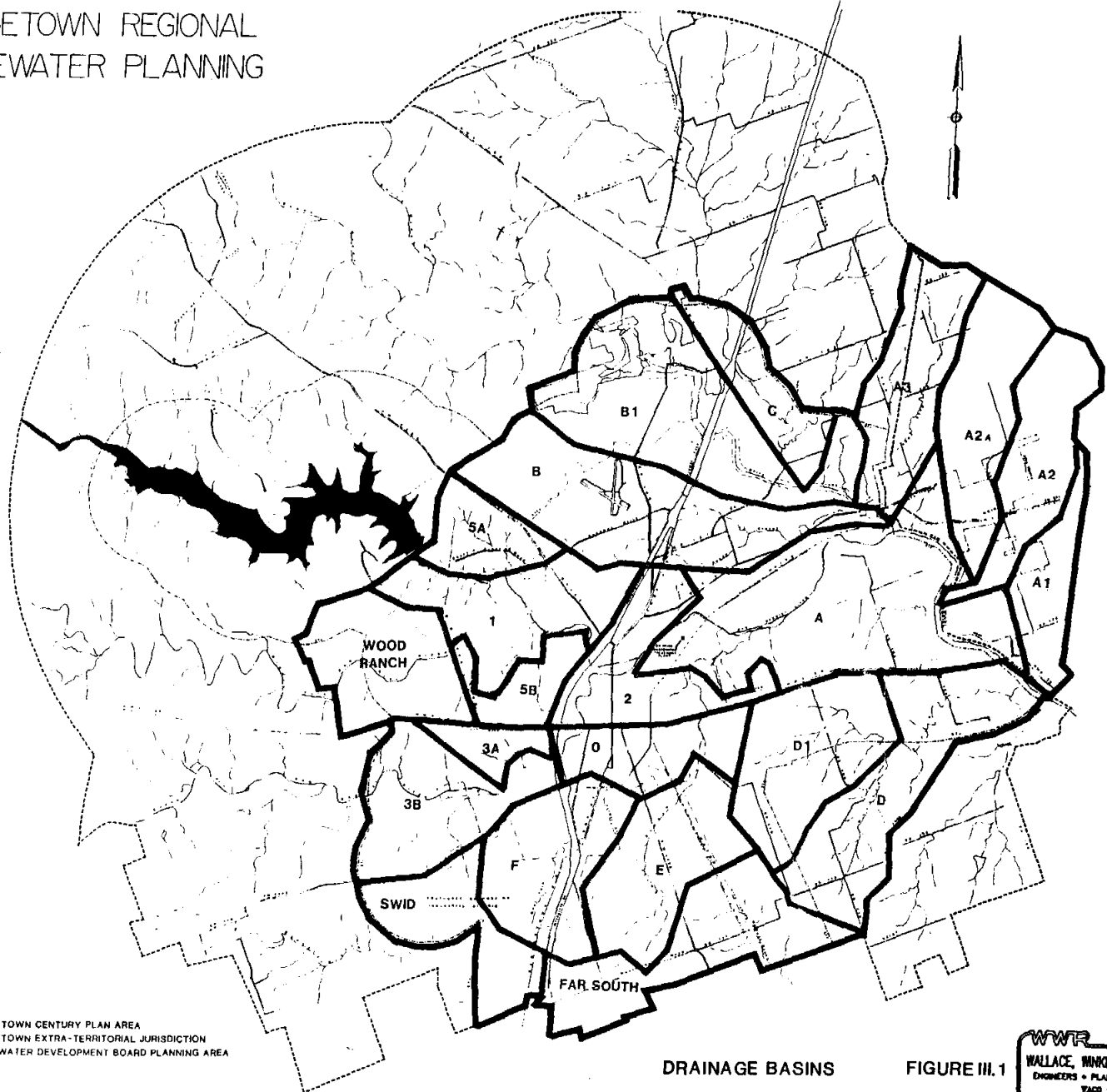

LEGEND
 - - - - GEORGETOWN CENTURY PLAN AREA
 GEORGETOWN EXTRA-TERRITORIAL JURISDICTION
 ——— TEXAS WATER DEVELOPMENT BOARD PLANNING AREA

DRAINAGE BASINS

FIGURE III.1

WWP
 WALLACE, WINKLER & RICE, INC.
 ENGINEERS • PLANNERS • SURVEYORS
 P.A.C.S. • TEXAS

the Southwestern Industrial District, Wood Ranch and the Far South, named more by description than by any level of service.

For basins 3a, 3b, 5a, and 5b, the forks of the San Gabriel River are boundaries which divide the entire basin into smaller sub-basins. These lines are additions to the City of Georgetown's existing interceptors called 3 and 5 in previous studies performed by Freese & Nichols.

Out of the 22 basins, 15 have outer boundaries described by the TWDB Planning Area Boundary.

III.A.2 Description of the Drainage Areas

Within the Berry Creek watershed, drainage area B has significant levels of development, several platted but undeveloped subdivisions, and contains the airport. Moving northward, B1 has considerable existing development, including Williamson County MUDs 5 and 6. Like area B, it has good access because it is dissected by IH 35, although the eastern portion may be dependent on the construction of the proposed Mokan Roadway for further growth. Area C also has good access that would be enhanced by the construction of Mokan. Although currently demonstrating limited development, it has good potential for growth through the 2030 planning horizon.

Areas A1, A2, A2a and the eastern half of A3 include the Town of Weir, which was incorporated in 1987. It is predominantly rural with dryland crop farming. The northeast quadrant of the Georgetown area has always experienced the slowest rates of growth, mostly because of accessibility problems and availability of adequate sewage collection and treatment facilities. This situation will continue until such time as the Mokan Roadway is completed or sewage collection and treatment facilities are constructed along the San Gabriel River below Berry Creek.

Another major ridge line is delineated by State Highway 29, which dissects the older portion of Georgetown. Drainage area 2, north of SH 29, and area 0, south of SH 29, contain most of old Georgetown. They have the highest population density and limited potential for growth. West of IH 35 and north of the Middle Fork San Gabriel, drainage area 1 is an extension of the development pattern of the downtown area. However, the western half is currently developed on septic tanks and contains large amounts of floodplain thereby limiting the intensity of growth possible.

North of SH, 29 and also developed to varying degrees on septic tanks are drainage areas 5A, 5B and A and the Wood Ranch Property. Both 5A and 5B have good access and therefore good potential for growth. In 1986 utilities were extended to 5B and a major commercial development (Rivery) has been planned and approved for this area. The Wood Ranch west of Georetown is designated as a separate area because of its large size under single ownership. Although discouraged by the Century Land Use Plan,

this makes it a potential candidate for designation as a municipal utility district unless City services are provided. It is currently undeveloped except for that portion used as a quarry by Capital Aggregates.

Area A, east of the developed portion of the town, contains the existing treatment plant and a significant area of City and university owned land. Growth potential for this area is severely limited due to large amounts of floodplain, lack of access and the relatively small parcel size of much of the land. There are, however, a handful of scattered tracts large enough to constitute a major development that could become marketable with the completion of the Mogan Roadway and addition of sewage collection and treatment facilities along the San Gabriel River.

With the exception of the previously discussed area 0 and limited portions of areas 3B and F, the area of urban development south of SH 29 has again been limited by availability of utility services. In an attempt to encourage growth in this area, the City has recently budgetted \$600,000 for the extension of water and sewer services. It hopes to encourage industrial development, particularly in area F which is dissected by IH 35 and already has significant residential and commercial areas. Adjacent area E has good potential for residential growth, if Westinghouse Road is widened and the development of the Georgetown Loop Road proceeds. These two areas have been given high priority for growth in the Georgetown Century Plan and by the Georgetown City Council.

In the southwest, areas 3A, 3B and the Southwest Industrial District (SWID) are relatively undeveloped and limited by lack of utilities. The eastern third of 3B is developed with higher density residential uses and significant commercial use. The western third contains a major rock quarry. Area 3A has relatively consolidated ownership but no apparent plans for development over the foreseeable future. Similarly, the SWID area is expected to continue its present use as a quarry through most of the study period.

The Mankin's Branch watershed in the southeast has been divided into areas D and D1. It contains several isolated septic tank subdivisions and the site of the proposed Dove Springs WWTP. There is considerable agricultural activity in the area, particularly dryland row crops and dairy farming. Future growth potential is poor unless the construction of the Mogan Roadway has a significant impact. However, taking into account floodplain and property ownership patterns, these areas are more conducive to development than area A to the north.

The Far South basin drains into the Brushy Creek watershed. There is high potential for future growth adjacent to IH 35, but wastewater would have to be pumped up into the San Gabriel River basin unless service could be arranged at the Brushy Creek Regional Wastewater Treatment Plant. Currently the area is predominantly rural with several horse breeders, but also contains a plastics manufacturing plant and

some "cottage" businesses. Widening of Westinghouse Road and completion of Mokon in addition to water and sewer services are crucial to the development of the eastern two-thirds of the area.

III.B Population Projections

III.B.1 Projecting Total Populations

Several attempts have been made to predict population growth rates in the Georgetown area. In general, the results obtained depend on the timing of the study. During the mid 1980s many population growth rate predictions were revised upwards because of the unprecedented rates of growth being experienced at that time. For instance, the 1985 addition to the 1983 study by Samuel Wyse Associates was specifically designed to revise earlier projections, based on current rates of growth. Now, with the current slow down in economic growth, earlier, more conservative growth rates seem more acceptable.

Population growth rates in this study rely heavily on estimates made by the TWDB, the City of Georgetown (the Century Plan) and Samuel Wyse Associates. The TWDB has determined for each county a high and low population projection scenario out to the year 2030. In this study all population projections have been guided by these limits. In its Century Plan, the City of Georgetown has developed population projections to the year 2010. The rates of growth predicted by the City closely track the TWDB's low estimates to the year 2000 and then increase so that by the year 2010 they exceed the TWDB high estimate. Thus, there is general agreement on the rate of population growth to the year 2000, and then it becomes more speculative.

In order to more closely track the TWDB projections, in this study, the rate of growth predicted for 1990-2000 was used to extrapolate out to the year 2010 using the City 2000 estimate as a baseline. This resulted in a value close to, but not exceeding, the TWDB upper limit. This figure was then used to extrapolate out to the years 2020 and 2030, using the same rates of growth as those used by the TWDB. Table III.1 shows the resulting estimates, together with the results of the studies previously discussed.

III.B.2 Projecting Population by Drainage Area

The most detailed attempts to predict the geographic distribution of growth in the Georgetown area were the studies carried out by Samuel Wyse Associates. Using total population projections, they distributed the population among single family and multi-family units and assigned these living units to different areas of the city based on development trends and some of the socio-economic and physical criteria discussed earlier. Detailed maps were produced showing existing dwelling units by drainage area and those predicted for the year 2005 (assuming 2.7 persons per unit).

**Table III.1
Georgetown Population Projections**

Year	City		TWDB (Low)		TWDB (High)		WWR	
	Total	%/year	Total	%/year	Total	%/year	Total	%/year
1980	9,441	8.0	9,441	7.9	9,441	9.9	9,441	7.4
1990	17,000	4.4	16,867	4.5	18,822	4.6	16,433	4.9
2000	24,500	6.6	24,388	2.8	27,514	3.6	24,500	4.9
2010	43,500		31,159	3.1	37,500	3.4	36,389	3.0
2020	-----		40,890	2.2	50,411	3.4	47,392	3.3
2030	-----		49,698		67,767		63,209	

Using the maps produced by Samuel Wyse Associates, the 23 drainage areas developed for this study were overlaid (Figure III.2). The 1985 population for each of these new areas was then recalculated to reflect any differential between them and the Wyse drainage basins (also called Planning Districts). Because the total 2005 population predicted by Samuel Wyse Associates (35,033) closely approximated the estimates made by the TWDB for the year 2010, the Wyse basin distributions were selected as the total population by area for the year 2010. Some adjustment was then made for the targetted growth in areas E and F, the implications of the Century Plan Draft Land Use Intensity Map, and population projections associated with the proposed development in MUDs 5 and 6 in area B1. The following assumptions were made:

- the total population for each decade must be equal to the numbers given in Table III.1 (plus the Town of Weir);
- the rate of growth in the downtown area (areas 0, 1 and 2) will probably be less than that of the area as a whole;
- growth is likely to be concentrated in those areas where residential subdivisions and commercial tracts are already proposed, especially areas B, B1, 5A, 5B, E and F;
- the construction of Mokan would favor development in drainage areas D1 and eastern portions of B and B1;

City of Georgetown, Texas

POPULATION DISTRIBUTION

L E G E N D
Existing Population
Future Population
Each Dot Represents 10 Dwelling
Units or About 27 Persons

WALLACE MANAGER & RICE, INC.
ENGINEERS - PLANNERS - SURVEYORS
1500 - 1502 - 1504

NORTH

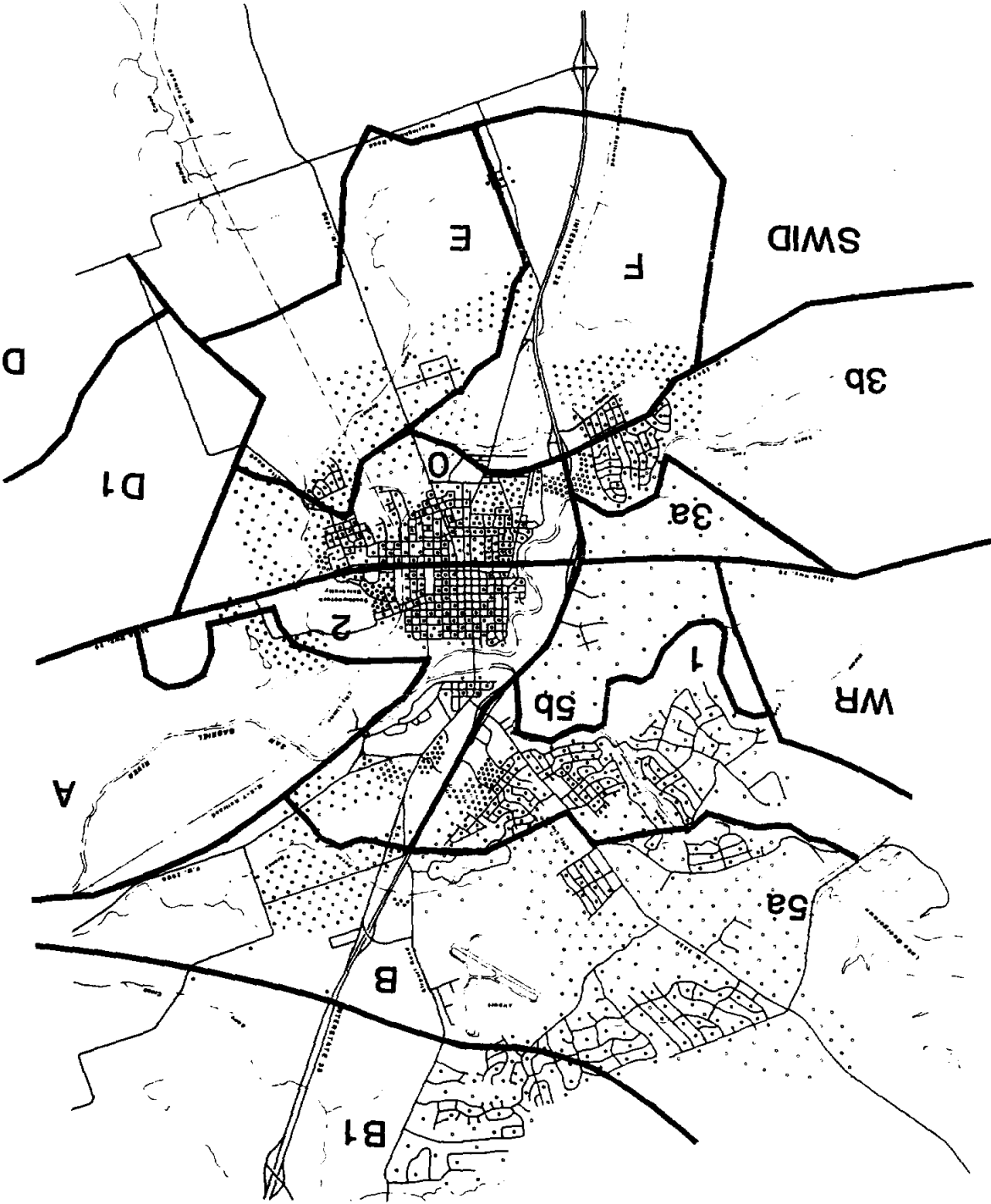

- the Town of Weir (areas A1, A2, A2a and A3) would grow at the same rate as the surrounding rural Williamson County, as estimated by the TWDB;

Using the present (1985) and future (2010) values for each drainage area, the rate of population growth in each was determined. These numbers were used to develop estimates for the years 1990 and 2000, assuming a linear rate of growth. Similar rates of growth for each drainage basin were used to project out to the years 2020 and 2030. Using all of these assumptions, the population estimates shown in Table III.2 were obtained.

**Table III.2
Population Projections for each Drainage Area**

Basin	Description	Projected Population				
		1990	2000	2010	2020	2030
0	Downtown (south)	3,438	5,164	7,497	8,327	10,290
1	North Fork San Gabriel	3,078	4,144	6,051	7,215	8,745
2	Downtown (north)	3,033	3,723	5,547	6,754	10,441
3a	South Fork San Gabriel	0	286	455	576	748
3b	South Fork San Gabriel	1,253	1,845	2,624	3,582	4,532
5a	Booty's Crossing	296	688	1,090	1,909	2,524
5b	Middle Fork San Gabriel	292	420	748	928	1,463
A	San Gabriel	350	635	1,145	1,477	1,998
B	Pecan Branch	1,552	2,313	3,145	4,095	5,446
B1	Berry Creek	1,900	2,832	4,471	5,419	7,207
C	Dry Berry Creek	0	0	0	0	0
D	Mankin's Branch	0	151	271	407	541
D1	North Mankin's Branch	130	192	324	447	682
E	Smith's Branch	275	576	1,210	2,541	3,831
F	I - 35 South	695	1,345	2,586	3,394	4,387
W.R.	Wood Ranch	141	186	226	321	373
SWID	Industrial District	0	0	0	0	0
F.S.	Westinghouse Road	0	0	0	0	0
A1	East Weir	35	64	90	115	151
A2	Middle Weir	92	140	186	238	314
A2a	West Weir	86	138	182	233	307
A3	East Fork San Gabriel	55	88	123	156	206
		16,701	24,930	36,971	48,134	64,186

III.C Projecting Wastewater Flows

Wastewater flows were determined for each drainage area from a combination of residential and commercial/industrial estimates. Residential flows were based on previously discussed population projections; commercial/industrial flows were estimated from available land use data. In all cases current use patterns

were used; no assumptions were made about water conservation. Using the data in Table III.2, residential uses were calculated assuming 110 gallons per person per day. This represents the current rate of wastewater generation in Georgetown, as published in the Century Plan Utilities Base Study (1987). Residential flows predicted for each drainage area are shown in Table III.3.

The City of Georgetown has implemented an intensive infiltration/inflow (I&I) remediation program aimed at reduction of identified excessive I&I problems. The goal of the program is to reduce average daily dry weather flows to levels acceptable under the SRF program (<120 gpcd). The Texas Design Criteria for Sewerage Systems (31 TAC §§317.4) recommends municipal sewerage collection system and WWTP designs based on 100 gpcd. The 110 gpcd used in this study is an average of recommended maximum and minimum design standards. However, with the implementation of a water conservation program that reduced water consumption by 15 percent, per capita flows would be less than 100 gallons per day.

**Table III.3
Residential Flow Projections for each Drainage Area**

Basin	Description	Projected Wastewater Flow (MGD) ^{a/}				
		1990	2000	2010	2020	2030
0	Downtown (south)	0.378	0.568	0.825	0.916	1.132
1	North Fork San Gabriel	0.339	0.456	0.666	0.794	0.962
2	Downtown (north)	0.334	0.410	0.610	0.743	1.149
3a	South Fork San Gabriel	0.000	0.031	0.050	0.063	0.082
3b	South Fork San Gabriel	0.138	0.203	0.289	0.394	0.499
5a	Booty's Crossing	0.033	0.076	0.120	0.210	0.278
5b	Middle Fork San Gabriel	0.032	0.046	0.082	0.102	0.161
A	San Gabriel	0.039	0.070	0.126	0.162	0.220
B	Pecan Branch	0.178	0.266	0.362	0.471	0.626
B1	Berry Creek	0.219	0.326	0.514	0.623	0.828
D	Mankin's Branch	0.000	0.017	0.030	0.045	0.060
D1	North Mankin's Branch	0.014	0.021	0.036	0.049	0.075
E	Smith's Branch	0.033	0.069	0.145	0.304	0.460
F	I - 35 South	0.076	0.148	0.284	0.373	0.483
W.R.	Wood Ranch	0.015	0.020	0.025	0.035	0.041
A1	East Weir	0.004	0.007	0.010	0.013	0.017
A2	Middle Weir	0.010	0.015	0.020	0.025	0.035
A2a	West Weir	0.009	0.015	0.020	0.026	0.034
A3	East Fork San Gabriel	0.006	0.010	0.012	0.018	0.022
		1.857	2.774	4.226	5.367	7.164

^{a/} Based on the population projections shown in Table III.2 and assuming 110 gpd.

Commercial/industrial estimates were based on land use intensity maps and the Equivalency Tables produced for the Century Plan. A two-step process was used. First, the total amount of commercial, industrial and public use acreage for a given population base had to be determined. This acreage then had to be

geographically distributed by drainage area. As described in Section II.B.2.a, Samuel Wyse Associates used the per capita amount of acreage typically needed to sustain a population to determine the amount of acreage needed for commercial, industrial and public uses for their 2005 estimated population. As explained earlier, their estimates were readily adapted to our 2010 estimates, given the discrepancy in total population predicted.

The Century Plan Land Use Intensity Map (Figure III.3) was then used to assign the total commercial, industrial and other acreage to specific drainage areas. Because the original land use intensity maps vastly overestimate the amount of acreage likely to be developed for each use, the number of developed acres was typically estimated as a percentage of total land area assigned to each use. Then, using values developed for Georgetown in the Century Plan Land Use Element for the wastewater production per acre for each use, the total industrial/commercial wastewater production per drainage area could be determined (see Table III.4). As with population projections, data for 2000, 2020 and 2030 were extrapolated from the rates of growth determined by comparing values for the present with those for 2010.

**Table III.4
Industrial Flow Projections for each Drainage Area**

Basin	Description	Projected Wastewater Flow (MGD) ^{a/}				
		1990	2000	2010	2020	2030
C	Dry Berry Creek	0.010	0.025	0.038	0.050	0.065
SWID	Industrial District	0.100	0.175	0.230	0.300	0.353
F.S.	Westinghouse Road	0.075	0.100	0.150	0.195	0.230
A3	East Fork San Gabriel	0.006	0.010	0.012	0.017	0.023
		0.191	0.310	0.431	0.562	0.671

^{a/} Based on land use intensity data developed in the Century Plan.

The values for wastewater flows produced from both residential and commercial/industrial were summed for each basin, as shown in Table III.5. Based on these estimates, total flows for the region will exceed 2 MGD by 1990 and will approach 8 MGD by the year 2030. However, as explained in Section X, a rigorous water conservation program could result in a considerable reduction in wastewater generation. The scenario described focuses on reducing water consumption in new construction (because of the high rates of projected growth) and assumes that a stringent plumbing code would reduce per capita wastewater generation from 110 gcd to 80 gcd. The overall result would be a 15-20 percent reduction in wastewater generation in the Georgetown area by the year 2020. We have not taken water conservation into account in developing the plant location scenarios, because it is unlikely to affect these decisions. However, it is abundantly clear from the discussion in Section VII that reducing wastewater generation could result in considerable cost savings, by delaying the construction of various phases of the project.

GEORGETOWN REGIONAL WASTEWATER PLANNING STUDY

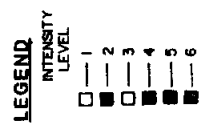
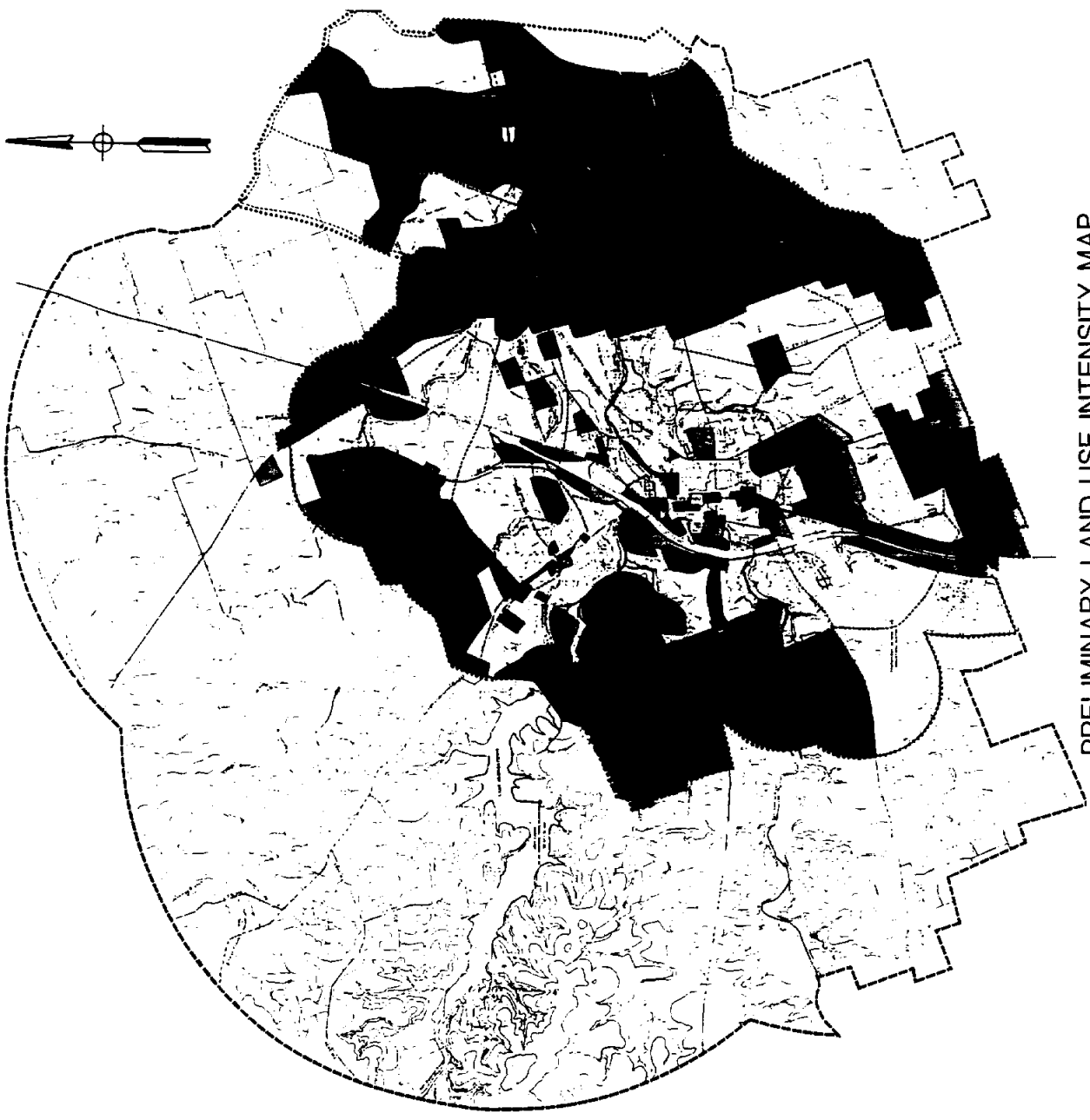

WWR
WALLACE, WARDLER & RICE, INC.
ENGINEERS • PLANNERS • SURVEYORS
2400 • TOWSON

PRELIMINARY LAND USE INTENSITY MAP

FIGURE III.3

**Table III.5
Total Flow Projections for each Drainage Area**

Basin	Description	Projected Wastewater Flow (MGD)				
		1990	2000	2010	2020	2030
0	Downtown (south)	0.378	0.568	0.825	0.916	1.132
1	North Fork San Gabriel	0.339	0.456	0.666	0.794	0.962
2	Downtown (north)	0.334	0.410	0.610	0.743	1.149
3a	South Fork San Gabriel	0.000	0.031	0.050	0.063	0.082
3b	South Fork San Gabriel	0.138	0.203	0.289	0.394	0.499
5a	Booty's Crossing	0.033	0.076	0.120	0.210	0.278
5b	Middle Fork San Gabriel	0.032	0.046	0.082	0.102	0.161
A	San Gabriel	0.039	0.070	0.126	0.162	0.220
B	Pecan Branch	0.178	0.266	0.362	0.471	0.626
B1	Berry Creek	0.219	0.326	0.514	0.623	0.828
C	Dry Berry Creek	0.010	0.025	0.038	0.050	0.065
D	Mankin's Branch	0.000	0.017	0.030	0.045	0.060
D1	North Mankin's Branch	0.014	0.021	0.036	0.049	0.075
E	Smith's Branch	0.033	0.069	0.145	0.304	0.460
F	I - 35 South	0.076	0.148	0.284	0.373	0.483
W.R.	Wood Ranch	0.015	0.020	0.025	0.035	0.041
SWID	Industrial District	0.100	0.175	0.230	0.300	0.353
F.S.	Westinghouse Road	0.075	0.100	0.150	0.195	0.230
A1	East Weir	0.004	0.007	0.010	0.013	0.017
A2	Middle Weir	0.010	0.015	0.020	0.025	0.035
A2a	West Weir	0.009	0.015	0.020	0.026	0.034
A3	East Fork San Gabriel	0.012	0.020	0.025	0.035	0.045
		2.048	3.084	4.657	5.928	7.835

IV IDENTIFICATION OF POTENTIAL TREATMENT PLANT SITES

IV.A Preliminary Screening of Potential Sites

The screening of potential sites for wastewater treatment facilities was a two-stage process. Initially, City staff selected fifteen sites, based on the following criteria:

- The topography of the area. Because gravity flow is the most economical way of transferring sewage from individual structures to the treatment plant, optimum locations would be downhill from a significant service area and at the confluence of several subareas.
- The lower limit of the largest service area is Mankin's Crossing, given the boundaries of this regional wastewater study.
- Williamson County MUDs 5 and 6 have a permit to treat wastewater and use the effluent for irrigation. Dove Springs Development Corporation has a 2.5 MGD permit but no facility has been constructed.
- There is market pressure to increase the quantity of development in the northwest portion of the City and this is dependent upon the provision of centralized wastewater treatment facilities in order to protect the Edwards Aquifer.
- The City wishes to encourage growth to the south of town and is taking appropriate steps to encourage this.
- Many existing lift stations are now or will become overloaded and offer the possibility of being consolidated and/or replaced by small treatment plants.

Using these criteria, fifteen sites were selected and the advantages and disadvantages of each delineated, as shown in Figure IV.1 and Table IV.1.

IV.B The Selection of Sites for Further Evaluation

In an attempt to quantify the next stage of the selection procedure, each of the 15 potential sites was rated with respect to the chosen criteria (see Table IV.2). The criteria were selected to encompass a variety of attributes, both physical and socio-economic. The importance given to each factor is reflected in the range of values assigned to it. The following rationale was used, with the criteria listed in order of importance:

GEORGETOWN REGIONAL
WASTEWATER PLANNING
STUDY

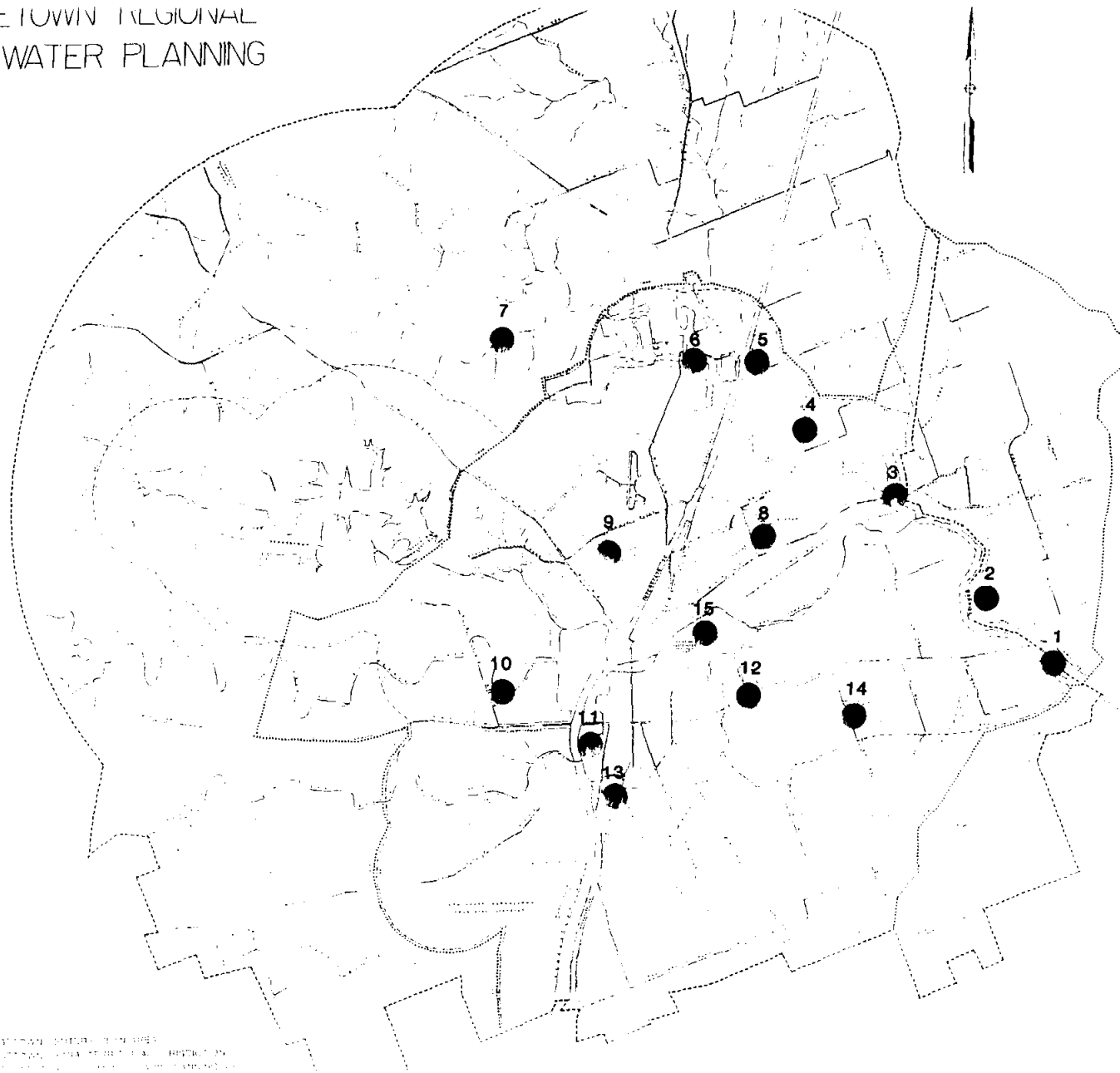

LEGEND

- REGIONAL BOUNDARY
- CITY BOUNDARY
- SEWER SERVICE AREA BOUNDARY

WWR
WALLACE, WINKLER & RICE, INC.
ENGINEERS • PLANNERS • SURVEYORS
VADO • TEMPE

FIGURE IV.1

Table IV.1
Potential Candidate Sites Chosen for Initial Screening

Site	Advantages	Disadvantages
1 Mankins Crossing - San Gabriel River between State Hwy 29 and Mankin's Branch Creek confluence	Could serve largest area by gravity Relatively remote	Largest distance from development Located in broad floodplain
2 Weir - San Gabriel River north of State Hwy 29 and south of Weir	Could serve large area by gravity Remote, but closer to development than Mankin's Crossing	Poor accessibility Significant distance from development Floodplain
3 Berrys Creek - near confluence of Berrys Creek and Pecan Branch with the San Gabriel River	Site previously studied Closest gravity site to Georgetown WWTP Good potential road and rail access Good location relative to projected near-term development	Significant portion of study area not served by gravity Located in broad floodplain Potential significant public opposition
4 Dry Berrys Creek near confluence with Berrys Creek	Site previously studied Could coincide with future development Remote location - potentially little public opposition	Poor access except adjacent to IH 35 Broad floodplain On Edwards Aquifer recharge zone Probability of significant public opposition Demand tied to Mogan Roadway
5 Dry Berrys Creek downstream of IH 35 crossing	Site previously studied Could coincide with future development Remote location - potentially little public opposition	Relatively small service area Poor access except adjacent to IH 35 On Edwards Aquifer recharge zone Demand tied closely to Mogan Roadway
6 Airport Rd - Berrys Creek between Airport Rd and IH 35	Existing zero discharge permits for WCMUDs # 5 & 6 Good potential access Consolidated ownership downstream Good future demand potential	Small service area On Edwards Aquifer recharge zone
7 Wilding - Berrys Creek between WCMUDs # 5 & 6 and WCMUDs # 7 & 8	Existing permits for WCMUDs # 7 & 8 Considerable septic tank development Remote location - potentially little public opposition Could coincide with future development	Uncertain future demand On Edwards Aquifer recharge zone
8 Crystall Knoll lift station on Pecan Branch Creek	Would eliminate existing lift station Moderately sized service area Good existing and future development Relatively good access and floodplain	Fragmented land ownership On Edwards Aquifer recharge zone
9 Reata lift station on Pecan Branch Creek	Would eliminate overloaded lift station Good existing and future development mix Good access Minimal floodplain problems	High land costs Potential for significant public opposition Relatively small service area On Edwards Aquifer recharge zone
10 Middle Fork of the San Gabriel above Georgetown Country Club	Moderately large service area with consolidated ownership Potential for irrigation of golf course Can serve Wood Ranch tract	Limited access Undeveloped service area Potential for significant public opposition On Edwards Aquifer recharge zone
11 South Fork of the San Gabriel above State Hwy 29 bridge	Moderately large service area Some existing development Could eliminate two existing lift stations	Broad floodplain location Potential for significant public opposition On Edwards Aquifer recharge zone
12 Smith Branch Creek near State Hwy 29 crossing	Could eliminate overloaded lift station Large service area with good existing and future development mix Potential for irrigation of golf course Consolidated land ownership	On Edwards Aquifer recharge zone Small gravity service area
13 Smith Branch Creek near Business 35	Would relieve overloaded lift station Near planned future development Recreational opportunities with discharge downstream Moderately large service area with good development mix	Potential for significant public opposition On Edwards Aquifer recharge zone High land costs
14 Unnamed fork of Mankins Branch Creek near CR 102 (Dove Springs WWTP site)	Discharge permit issued Could serve Smith Branch Interceptor Near existing development Property available	Very small gravity service area Future development closely tied to Mogan Roadway
15 Current City of Georgetown plant	Minimal potential public opposition Minimal development problems Good service area	Cannot accommodate larger service area On Edwards Aquifer recharge zone

Table IV.2
Criteria Used to Evaluate Potential Wastewater Treatment Plant Locations

Criteria b/	Site a/														
	1	2	3	4	5	6	7	8	9	10	11	12	13	14	15
Size of Service Area	10	8	6	3	1	1	0	2	1	1	1	4	2	0	5
On Edwards Aquifer	0	0	0	-10	-10	-10	-10	-10	-10	-10	-10	-10	-1	0	-10
Amount of Existing Development	1	2	3	1	1	3	2	4	5	-	3	5	5	2	6
Potential For Development	1	2	3	4	3	6	4	4	3	3	3	5	5	2	4
Previous Investment/Infrastructure	2	0	2	2	2	4	4	6	7	0	5	8	2	4	10
Potential for Public Opposition	-2	-3	-5	-3	-2	-2	-2	-3	-6	-6	-4	-2	-3	-2	0
Site Availability	3	4	2	3	4	4	4	4	3	4	2	4	4	5	6
Accessibility	4	2	4	2	5	5	2	5	4	4	2	6	6	4	6
Floodplain	-4	-3	-1	-4	-3	-3	-3	-2	-2	-3	-4	-3	-2	0	0
TOTAL	15 c/	12 d/	10 c/	-2	1	8	1	10	5	-7	-2	17 e/	9	15 c/	27 c/

a/ Site location numbers:

- 1 Mankin's Crossing SGR
- 2 Town of Weir SGR
- 3 Berry Creek SGR
- 4 Dry Bert Creek SGR
- 5 Dry Berry Creek IH-35
- 6 Airport Road BC
- 7 Wilding BC
- 8 Crystal Knoll PBC
- 9 Reata PBC
- 10 Middle Gabriel
- 11 South Fork
- 12 Southwestern SBC
- 13 Business IH-35 SBC
- 14 Doves Springs MBC
- 15 Existing Georgetown WWTP SGR

b/ Range of Ranking Values:

- Size of Service Area => 0 to 10
- On Edwards Aquifer => 0 or -10
- Amount of Existing and Potential Development => 0 to 10
- Previous Investment/Infrastructure => 0 to 10
- Potential for Public Opposition => -6 to 0
- Site Availability => 0 to 6
- Accessibility => 0 to 6
- Floodplain => -6 to 0

c/ Selected for further evaluation

d/ Not selected because of its proximity to Sites 1 and 3.

e/ Not selected because of its proximity to Site 15, the existing Georgetown WWTP.

- The size of the service area served by gravity was considered to be the most important factor and rated on a scale of 1 to 10. This factor could be critical in determining the economic viability of a given site.
- The location of the potential site with respect to the Edwards Aquifer is probably just as important and could be determinative, unless an outfall pipe could be built in order to discharge effluent below the fault line. The Texas Water Commission has adopted TWC Rule 313 which essentially prohibits the permitting and construction of new wastewater treatment facilities discharging to any water course on the Edward's recharge zone; two recent discharge permit applications within the Georgetown study area were denied for this reason. Sites located on the Edwards Aquifer were given a negative, -10 rating.
- The amount of development served by the potential site also relates to the economic viability of a site. A total potential score of 10 was used to reflect the importance of this factor. Different criteria were used to assess existing development and the potential for future growth, because of the uncertainty associated with the latter.
- The relationship of the site to existing infrastructure (collection systems and lift stations), as well as other types of investment such as previous studies and/or wastewater treatment plant permits, was rated on a scale of 1 to 10.
- The potential for public opposition was considered to be of somewhat lesser importance and was rated on a scale of 0 to -6.
- Three physical characteristics of the site, availability, accessibility and relationship to the floodplain, were each rated on a scale of 1 to 6. None of these features was considered to be determinative in site location decisions, but could be significant in assessing the cost of each option.

Summing the values obtained for each site resulted in a potential maximum score of 42 and an minimum of -22. Seven sites scored a value of 10 or higher and were considered for further evaluation:

- Current City of Georgetown plant (Site 15) rated highest and was chosen for further evaluation. Its main advantages are the existing infrastructure at the site, the availability of land and probability of limited public opposition. Although it already has a moderately-sized service area, its main drawbacks are the limited potential for an increase in the size of its service area and the fact that it is located on the Edward Aquifer recharge zone.

- Smith Branch Creek near State Highway 29 (Site 12) had the second highest score with many of the attributes of the current site. It is the site of an existing lift station that presently diverts flows to the downtown location. Because of its close proximity to the downtown site and the fact that it is located on the Edwards Aquifer recharge zone, it was felt that it could continue to serve as the site of a lift station, serving either the downtown or Dove Springs site. It was not considered for further evaluation.
- Unnamed fork of Mankin's Branch Creek near CR 102 (Site 14, Dove Springs site) is a site that already has a permit for a 0.2 MGD WWTP. Its main advantage is that it is off the Edwards Aquifer recharge zone. However, it has a very small gravity service area and wastewater flows would have to be pumped into the drainage basin. It was further evaluated as the potential site for a small WWTP.
- Mankin's Crossing (Site 1) had the same overall rating as the Dove Springs site and was considered for further evaluation. Although somewhat remote from existing and potential development, it has the largest gravity service area.
- Weir (Site 2) is upstream from Mankin's Crossing. Its close proximity to Mankin's Crossing and the fact that it had a slightly smaller service area eliminated it from further consideration.
- Berry Creek near the confluence with Pecan Branch (Site 3) has many of the attributes of Mankin's Crossing. Being further upstream it has a smaller service area but is closer to existing and potential development. It was evaluated in the context of a multi-plant scenario.
- Crystal Knoll lift station (Site 8) has a moderately-sized service area not far from downtown. However, because it is located on the Edwards Aquifer recharge zone and wastewater could be gravity fed to the Berry Creek site, it was not considered further.

The four selected sites, the current City of Georgetown plant, Dove Springs, Mankin's Crossing and Berry Creek, were then assessed in various combinations with respect to water quality effects, as described in Section V. The wastewater flow projections described in Section III were used to predict the wastewater load that would realistically be diverted to each site under each development scenario.

V SAN GABRIEL RIVER AND LAKE GRANGER WASTELOAD EVALUATION

V.A Introduction

V.A.1 Hydrology

Segment 1248 of the San Gabriel River (North Fork) is located in Central Texas in the Brazos River Basin. It extends from Lake Georgetown at the North San Gabriel Dam a total of 38.3 kilometers (23.7 miles) to the headwaters of Granger Lake, a point 1.9 kilometers (1.2 miles) downstream of SH 95. The drainage area totals 973.4 square kilometers (375.9 square miles), including parts of Williamson and Burnet Counties, as well as the City of Georgetown, portions of Bertram and several small communities. Seven kilometers (4.3 miles) below the Lake Georgetown dam is the confluence with the South Fork San Gabriel River. Other major tributaries are the Middle Fork San Gabriel, Berry Creek, Pecan Branch, Smith Branch and Mankin's Branch.

Lake Granger (Segment 1247) is located in central Texas about 6.5 miles east of the City of Granger and 9.5 miles northeast of the City of Taylor. The lake constitutes a 21,000 acre impoundment along the San Gabriel River as a result of a 15,240 foot long dam 31.9 river miles upstream from its confluence with the Little River.

Both segments receive much of their flow during spring months, both from surface run-off and from springs in the Edwards Aquifer and associated limestone formations. Notable springs are Berry Springs located 8.1 kilometers (5.0 miles) north of Georgetown on Berry Creek, and Mankin's Branch Springs 9.7 kilometers (6.0 miles) east of Georgetown on Mankin's Branch. In the Circleville vicinity the Wilson Springs contribute flow from the Wolfe City Sands.

Segment 1248 has been regulated since March 1980 by the North San Gabriel Dam at the headwaters. A statistical analysis of flow data collected since this time was performed to determine the 7-day 2-year low-flow value (7Q2) for Segment 1248. The results obtained from USGS stations are shown in Table V.1, together with those for two tributary stations collected over the period of record, 1968-1984.

Table V.1
7-day 2-year Low-flows (7Q2) for Segment 1248

USGS Station Number	Location	7-day 2-year low-flow	
		m ³ /s	ft ³ /s
08104700	Upstream of IH 35 northwest of Georgetown	0.007	0.24
08105300	Near Weir	0.328	11.57
08104900	South Fork San Gabriel River at Georgetown	0.009	0.33
08105100	Berry Creek near Georgetown	0.005	0.18

The stream channel is deeply eroded to limestone beds 3.1 to 4.6 meters (10-15 feet) below the floodplain. It is surrounded by a wide, wooded river valley with gently-sloping grassy banks. Elevation of the mainstem decreases from 244 meters (800 feet) at the headwaters to 165 meters (540 feet) at the its boundary with Segment 1247, an average slope of 0.0021.

V. A. 2 Water Quality Standards

Pursuant to Texas Water Code §26.023 and Federal Water Pollution Control Act §303, rules on required water quality standards and numerical criteria have been developed for both segments. The rules concerning Texas Surface Water Quality Standards are contained in 31 TAC §§333.11-333.21 and in the most current TWC publication of the Texas Surface Water Quality Standards.

For Segments 1247 and 1248 of the San Gabriel River the designated uses are: contact recreation, high quality aquatic habitat and public water supply. The numerical criteria developed for the San Gabriel River are intended to ensure water quality consistent with these designated uses. The water quality criteria of both segment are shown in Table V.2.

**Table V.2
Water Quality Criteria of Segments 1247 and 1248**

Parameter	Segment 1247	Segment 1248
Dissolved oxygen	Not less than 5 mg/L	Not less than 5 mg/L
pH (range)	6.5 to 9.0	6.5 to 9.0
Temperature	Not to exceed 90°F	Not to exceed 95°F
Chloride (annual average)	Not to exceed 25 mg/L	Not to exceed 35 mg/L
Sulfate (annual average)	Not to exceed 30 mg/L	Not to exceed 30 mg/L
Total dissolved solids (annual average)	Not to exceed 290 mg/L	Not to exceed 350 mg/L
Fecal coliform (30-day geometric mean)	Not to exceed 200/100 mL	Not to exceed 200/100 mL

The new Texas Water Quality Standards (adopted April 4, 1988) condition permit issuance on nonimpairment of designated uses. Therefore, not only must the numerical criteria of the segment be maintained, but all designated uses must be maintained. Deviation from these rules can only be accomplished through implementation of a Use Attainability Study conducted under the guidance of the U.S. Environmental Protection Agency.

Determination of criteria attainment is made from samples collected one foot below the water surface (or one third of the water depth if the depth is less than 1.5 feet) if the stream exhibits a vertically mixed water column. If the stream is vertically stratified, a depth integrated sample is required. Sampling is required four or more times a year. Exceptions to these numerical criteria apply whenever the flow equals or exceeds the low flow criteria, defined as either the 7Q2 or 0.0028 m³/s (0.1 ft³/s), whichever value is higher.

V.A.3 Wastewater Discharges

Approved, pending and projected permits for wastewater discharge affecting Segment 1248 of the San Gabriel River as of January 15, 1987 are shown in Table V.3. Existing loadings are based on monthly self-reporting data. Permitted loadings are based on the 30-day (or annual) average value in the permit. Ammonia nitrogen loading is based on an assumed effluent concentration of 15 mg/L NH₃-N for those domestic discharges that do not have a permitted NH₃-N limitation or that did not self-report NH₃-N.

In general, the current permit limitations required for domestic discharges to the San Gabriel River required advanced secondary treatment. Final permit limitations for the two existing dischargers total 0.13 m³/s, 110 kg/day BOD₅ and 165 kg/day NH₃-N (2.9 MGD, 242 lb/day BOD₅ and 365 lb/day NH₃-N). If approved, pending applications would add 0.03 m³/s, 29 kg/day BOD₅ and 20 kg/day NH₃-N (0.8 MGD, 65 lb/day BOD₅ and 44 lb/day NH₃-N).

Wastewater flows have increased over the period of record from approximately 0.5 MGD in 1975 to 1.6 MGD in 1985 and are projected at 2.5 MGD by 1990 without water conservation. However, since 1983 BOD₅ loadings have decreased significantly, from a high of 210 lb/day to 31 lb/day in 1985, as a result of improvements to the Georgetown wastewater treatment plant.

There are no direct dischargers to Lake Granger (Segment 1247) or its tributaries within 5 miles of the reservoir. However, Texas Water Code §§ 309.3(d) requires all new dischargers within five miles of a public drinking water supply reservoir that discharge into tributaries to that reservoir must treat to at least a level of modified secondary treatment with enhanced solids separation.

V.A.4 Water Quality Conditions

Data stored in the Texas Natural Resources Information Service (TNRIS) Stream Monitoring Network (SMN) data base, which includes that collected by TWC at two monitoring stations within Segment 1248, indicate that all of the mean values for measurements taken during the period October 1, 1981 and September 30, 1985 are within the numerical criteria. A minimum dissolved oxygen level measurement of 3.7 mg/L and a maximum fecal coliform sample of 512/100 mL indicate that violations occurred during the period.

Table V.3
Existing, Projected, and Permitted Wastewater Loading to
Segment 1248 of the San Gabriel River ^{#/}

Discharger name Permit No.	River Kilometer	Status	Flow (MGD)	BOD ₅ (mg/L)	NH ₃ -N (mg/L)	DO (mg/L)	BOD ₅ (lb/day)	NH ₃ -N (lb/day)
Georgetown (10489.002)	96.3	Existing (1985)	1.6017	2.3	15.0	5.0	30.5	200.4
		Projected (2005)	2.8000	10.0	3.0	4.0	233.5	70.1
		Permitted (final)	2.5000	10.0	15.0	2.0	208.5	312.8
SCB Development Company (12831.001)	89.7 (8.0)	Existing (1985)		No discharge				
		Projected (2005)	0.4000	10.0	15.0	4.0	33.4	50.0
		Permitted (final)	0.4000	10.0	15.0	2.0	33.4	50.0
168 Acre No Georgetown J V (13261.001 Pdg)	89.7 (15.8)	Existing (1985)		Not in existence				
		Projected (2005)	0.3250	10.0	3.0	4.0	27.1	8.1
		Pending permit	0.3250	10.0	3.0	4.0	27.1	8.1
Pecan Branch Utility (13297.001 Pdg)	89.7	Existing (1985)		Not in existence				
		Projected (2005)	0.2000	10.0	3.0	4.0	16.7	5.0
		Pending permit	0.2000	10.0	3.0	4.0	16.7	5.0
Dove Springs Development Co. (13322.001)	84.2 (6.9)	Existing (1985)		Not in existence				
		Projected (2005)	0.2500	10.0	15.0	4.0	20.8	31.3
		Permitted (final)	0.2500	10.0	15.0	4.0	20.8	31.3

^{#/} As used in the TWC Segment 1248 Wasteload Evaluation.

SMN dissolved oxygen trend data collected at SH 29 east of Georgetown indicate average values greater than the criterion of 5 mg/l. in all years from 1968 to 1985. Minimum values below the criterion were obtained in two years. At the low water crossing in San Gabriel Park at Georgetown, upstream of the Georgetown discharge, all SMN measurements for the period of record have been greater than the criterion. Data collected between 1974 and 1985 from the North Fork San Gabriel at IH 35 in Georgetown, again, upstream of the Georgetown discharge, indicate that dissolved oxygen levels remained above the criterion for this period.

Likewise, SMN data indicate relatively good water quality for Segment 1247.

V.A.5 Classification and Rank

Classification and Rank are taken from The State of Texas Water Quality Inventory (1988) prepared by TWC. Segment 1248 was classified as "water quality limited" and ranked 34 out of a possible 342. TWC designation of a segment as "water quality limited" as opposed to an "effluent limited" designation, indicated that there is either a demonstrated history of water quality standard violations within the segment or that there is a significant probability, usually demonstrated through model studies, that there will be violations of the State standards resulting from future development discharges at conventional treatment levels. For "water quality limited" segments, treatment levels for each proposed discharge are considered on a case-by-case basis. Each proposed discharge is analyzed with respect to its individual impact as well as the cumulative impact of all other dischargers to the segment on the designated uses and water quality standards of that segment. Hence, each proposed discharge flow and location must be modeled to determine the synergistic effect of it and other existing or proposed discharges. Segment 1247 is not ranked.

V.B QUAL-TX Surface Water Quality Model Simulations

V.B.1 Impact Analysis Overview

Water quality simulations using the QUAL-TX Model can serve two separate functions: (1) for existing or proposed facilities, the model can be used to predict the DO concentrations downstream of the treatment plant outfall under existing or proposed conditions; and (2) where minimum receiving streamwater quality criteria have been established, the model can be used to analyze any number of proposed facility location and treatment level scenarios.

The scope of this modeling analysis included simulation of the main stem of the San Gabriel River between Lake Georgetown and Lake Granger (Segment 1248) under a variety of proposed wastewater treatment plant locations, each at different flows and treatment levels. The goal of this QUAL-TX Model

application was to provide information on treatment plant locations and treatment levels necessary to maintain DO levels downstream of the outfall(s) above the minimum standard of 5 mg/L.

Serious candidate sites were further analyzed to determine appropriate treatment levels necessary to preserve the numeric water quality criteria and designated uses of the San Gabriel River. Section VIII describes how this information was used with the engineering and economic analyses to develop a set of options for future wastewater collection and treatment in the Georgetown area through the year 2030.

V.B.2 Model Description and Formulation

V.B.2.a General

Impacts of wastewater discharges on receiving streams are generally predicted and evaluated through the application of computer simulation models. These models vary in complexity from simple dissolved oxygen (DO) models to full ecological models which are capable of predicting populations densities of algae, production of macrophytes and other rooted aquatic plants, and fish populations. Selection of an appropriate model is generally a function of the level of sophistication required by a particular application and the availability of data. The more sophisticated the model, the more data it generally requires.

In addition to their use as tools in impact analyses of proposed actions, these models are frequently used as design aids in determining the assimilative capacity of receiving streams, constrained by the prescribed standards for that particular water body. Through iterative application of the simulation models, appropriate effluent limits can be established for proposed wastewater treatment facilities. The TWC generally accepts the QUAL-TX Steady-State Stream Simulation Model as the standard in the evaluation of impacts of a proposed WWTP discharge on the receiving stream water quality and performance of wasteload evaluations.

QUAL-TX is a longitudinally segmented steady-state simulation model that attempts to account for the major sources and sinks of a number of water quality constituents in a system composed of a number of complex interacting subsystems, each with its own set of physical and biological characteristics (Figures V.1 and V.2). The model is capable of computing longitudinal concentrations of a number of physical, chemical and biological water quality parameters such as: stream velocity, width, depth, temperature and dispersion characteristics; biochemical oxygen demand, dissolved oxygen, ammonia, nitrite, nitrate and phosphorus concentrations; and production of algae and macrophytes.

In most applications, the primary parameter of interest in QUAL-TX simulations is dissolved oxygen, which is computed as a function of the following simultaneous actions:

Segment 1248 Upper Boundary
Releases/Splits from Lake Georgetown

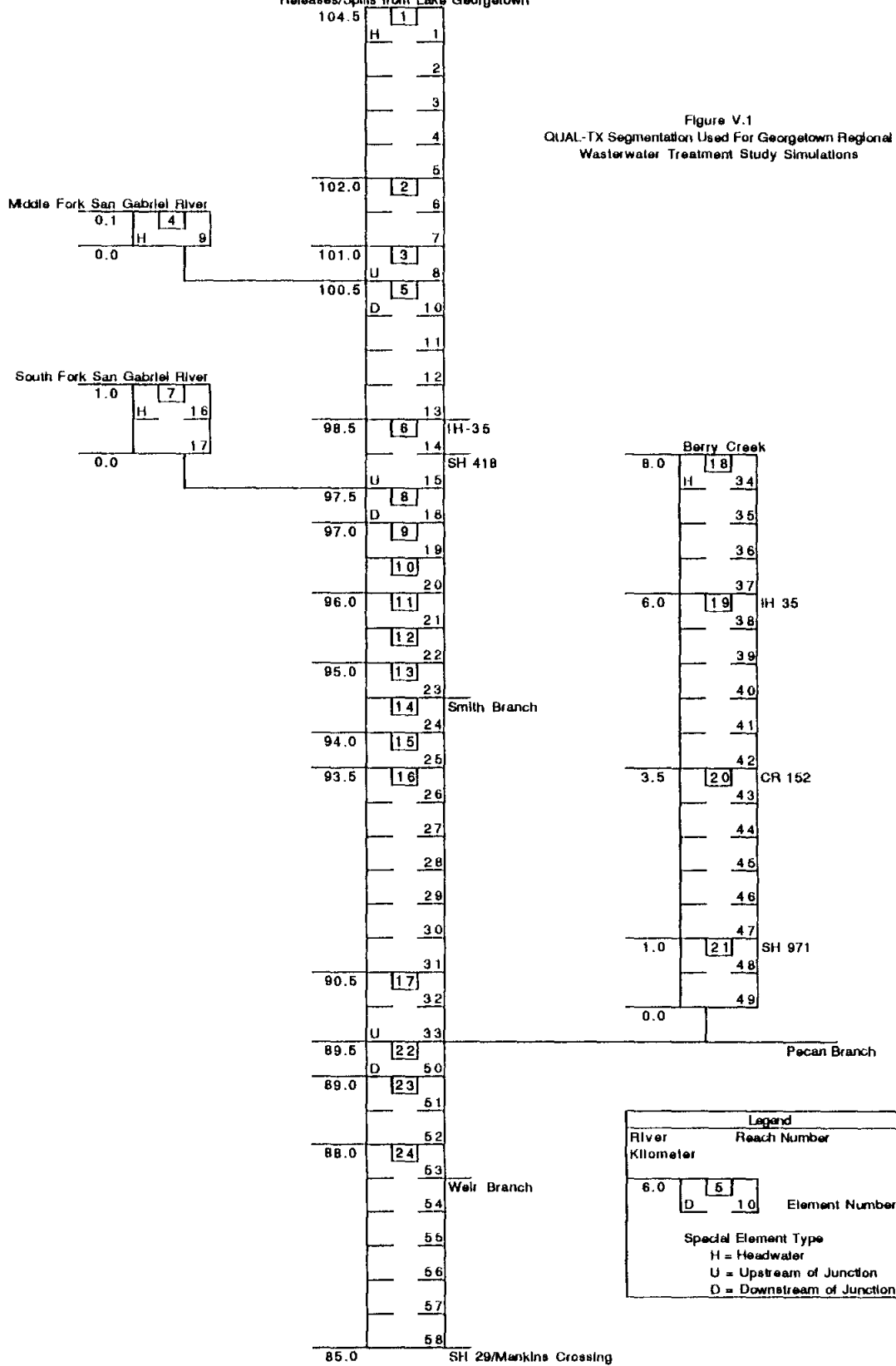
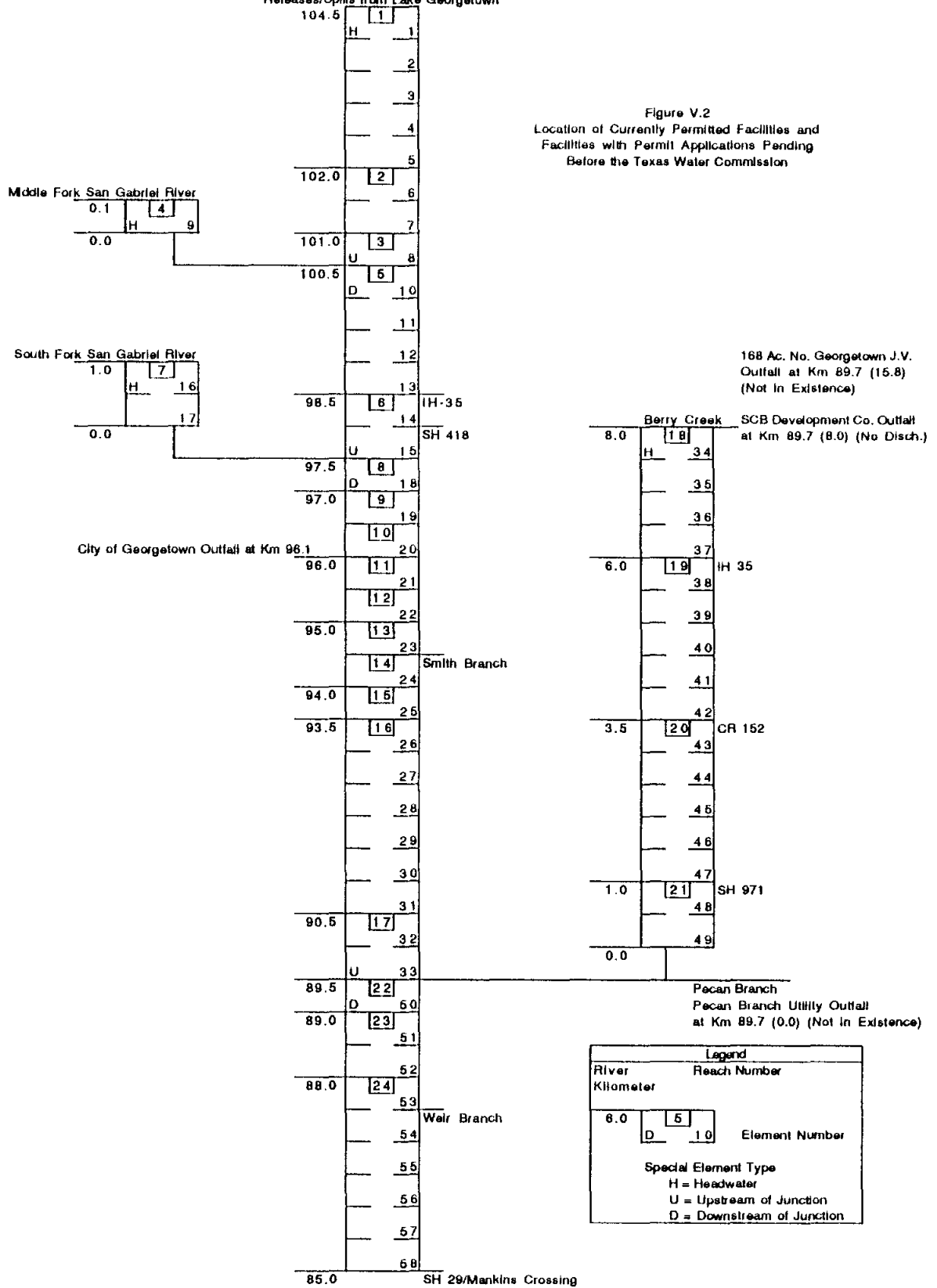

Figure V.1
 QUAL-TX Segmentation Used For Georgetown Regional
 Wastewater Treatment Study Simulations
 (Continued)

85.0	25	SH 29/Mankins Crossing
		59
		60
		61
		62
		63
		64
		65
		66
		67
80.5	26	FM 1660
		68
		69
		70
		71
		72
		73
		74
		75
76.5	27	
		76
		77
		78
		79
		80
		81
		82
73.0	28	
		83
		84
		85
		86
		87
		88
		89
		90
		91
		92
68.0	29	SH 95
		93
		94
		Pecan Branch
		95
		96
66.0		Segment 1248 Lower Boundary Segment 1247 Upper Boundary (Lake Granger)

Segment 1248 Upper Boundary
Releases/Spills from Lake Georgetown



85.0	25	SH 29/Mankins Crossing
	59	
	60	Dove Springs Development Co. Outfall at Km 84.2 (Not In Existence)
	61	
	62	
	63	
	64	
	65	
	66	
	67	
80.5	26	FM 1660
	68	
	69	
	70	
	71	
	72	
	73	
	74	
	75	
76.5	27	
	76	
	77	
	78	
	79	
	80	
	81	
	82	
73.0	28	
	83	
	84	
	85	
	86	
	87	
	88	
	89	
	90	
	91	
	92	
68.0	29	SH 96
	93	
	94	Pecan Branch
	95	
	96	
66.0		Segment 1248 Lower Boundary Segment 1247 Upper Boundary

Figure V.2
Location of Currently Permitted Facilities and
Facilities with Permit Applications Pending
Before the Texas Water Commission
(Continued)

- DO consumption through biochemical oxidation of dissolved and suspended organic material not removed in the wastewater treatment process (BOD);
- DO consumption through biochemical oxidation of ammonia (NH₃) to nitrite (NO₂) and then nitrate (NO₃);
- DO consumption through biochemical oxidation of organic sediments (SOD);
- DO consumption through algal respiration at night;
- DO production through natural diffusion and turbulent mixing at the air/water interface;
- DO production through day-time algal photosynthesis.

A simplification of the basic QUAL-TX oxygen balance equation is:

$$DO = DO_o - BOD - NOD - SOD - RESP + REAER + PROD \quad [V-1]$$

where,

DO	=	dissolved oxygen concentration,
DO _o	=	initial condition dissolved oxygen,
BOD	=	biochemical oxygen demand ,
NOD	=	nitrogenous oxygen demand,
SOD	=	sediment oxygen demand ,
RESP	=	oxygen consumed by algal respiration,
REAER	=	oxygen added to the water column through reaeration, and
PROD	=	oxygen produced by algae photosynthesis.

However, in other applications the primary interest may be the rate of removal of a specific parameter, the concentration of a parameter at a specific location downstream of the discharge, or the production of algae or rooted aquatic plants.

V.B.2.b Segmentation

The QUAL-TX model considers a series of longitudinally-oriented computational elements representing stream segments. During simulation the concentration of a water quality constituent is calculated by:

$$C = C_{in} + C_w \pm \text{Reaction} - C_{out} \quad [V-2]$$

where

C	=	the concentration of the constituent within the element
C _{in}	=	the concentration from the previous element, transported by flow
C _w	=	any concentration added to the element from an outside source
C _{out}	=	the concentration to the next element, transported by flow

The element length for each situation is a function of data availability, computation time and desired solution accuracy. Intuitively, an element length of one meter would allow for a more representative simulation than a 500-meter element length given the availability of data at one-meter intervals. Because computer

time for simulation is greater with decreasing element size, a balance must be determined between computation time and resulting solution accuracy. Generally, data are available at several hundred meter or kilometer intervals, and a 0.5 to 1.0 kilometer element size is used.

Elements representing stream segments with similar physical and chemical characteristics are grouped into reaches. Modeling reaches of a stream generally represents the transport of flow from the source, or headwaters, to the lower boundary. Tributaries are represented by separate reaches and contribute flow at intermediate points along the mainstem. Hydraulic characteristics and biological and physical rate coefficients may be specified for individual reaches.

V.B.2.c Hydraulics

The hydraulic characterization of stream segments is important in dissolved oxygen modeling as physical properties of a system directly affect atmospheric reaeration, a primary DO source. Because the shape of a stream changes as a function of flow, flow-dependent velocity and depth equations are necessary for each stream reach. These equations are:

$$V = aQ^b \qquad D = cQ^d \qquad W = eQ^f \qquad [V-3], [V-4], [V-5]$$

where

- V = velocity
- Q = flow
- D = depth
- W = width
- a,c,e = coefficients
- b,d,f = exponents

According to the laws of continuity, $Q/V/W$ must equal D , and, therefore $b+d+f$ must equal 1.0. When data are not sufficient to regress these exponential values, typical values are assumed and the velocity and depth coefficients a and c may then be calculated from known velocity, depth and flow relationships.

V.B.2.d Water Quality Kinetics

This section describes individual physical or chemical parameters and the associated sources (+) and sinks (-) considered by the QUAL-TX model for each parameter.

Carbonaceous Biochemical Oxygen Demand (CBOD)

BOD is the dissolved and suspended organic material in the water column. CBOD refers specifically to the carbonaceous portion of the material and excludes any nitrogenous components. CBOD is expressed in terms of either oxygen demand or oxygen used in the decay of the substance, not in terms of the specific substance. CBOD may generally be accounted for as follows:

$$CBOD = CBOD_{\text{wasteload contributions}} + CBOD_{\text{runoff contributions}} - CBOD_{\text{decayed}} - CBOD_{\text{settled}} \quad [V-6]$$

Nitrogenous Biochemical Oxygen Demand (NOD or NBOD)

NOD refers to the nitrogenous portion of dissolved and suspended organic material in the water column. The nitrogen series consists of organic nitrogen (ORGN), ammonia nitrogen (NH₃), nitrite nitrogen (NO₂), and nitrate nitrogen (NO₃). As ORGN decays, it becomes NH₃ which oxidizes to form NO₂ and NO₃. Because the reaction from NO₂ to NO₃ is usually instantaneous, these two components are usually expressed as one (NO₂₊₃). The oxidation of NH₃ utilizes dissolved oxygen at a laboratory rate of about 4.33 mg/L oxygen consumed per 1 mg/L NH₃ oxidized. NH₃ and NO₂₊₃ are also consumed by algae and macrophytes as nutrients. All of these forms of nitrogen are contributed to a system by point source wasteloads, as well as by natural contributors. Water column sources and sinks may be generalized as follows:

$$\begin{aligned}
 \text{ORGN} &= \text{Algal biomass} - \text{ORGN decay} - \text{ORGN settling} \\
 \text{NH}_3 &= \text{Decayed ORGN} - \text{NH}_3 \text{ decayed} - \text{Algal uptake} \\
 \text{NO}_2+\text{NO}_3 &= \text{Decayed NH}_3 - \text{Algal uptake}
 \end{aligned}$$

Sediment Oxygen Demand (SOD)

SOD is the settled organic material which decays to exert an oxygen demand from the water column. Naturally-occurring SOD is commonly caused by settled detritus in a stream. In theory, 100 percent of all settled organic material becomes an oxygen-demanding substance. Realistically, however, in areas where settling velocities are large compared to advective velocities, sediment layers may build up so that only a thin top layer is exposed to the dissolved oxygen in the water column. QUAL-TX allows for this occurrence by providing a percent conversion factor for both settled CBOD and ORGN. SOD is considered within QUAL-TX as:

$$\text{SOD} = \text{SOD}_{\text{background}} + \text{CBOD}_{\text{settled}} + \text{ORGN}_{\text{settled}} \quad \text{[V-7]}$$

Atmospheric Reaeration (K₂)

Reaeration is a term used to describe natural diffusion and turbulent mixing at the air/water interface. At the primary DO source, reaeration is generally expressed as a function of stream velocity and depth. Several equations are available for the calculation of atmospheric reaeration in this manner as implied by the following:

$$K_2 \text{ at } 20^\circ \text{C} = \frac{aV^b}{D^c} \quad \text{[V-8]}$$

where

- V = velocity
- D = depth
- a,b,c = constants

The TWC generally uses the Texas equation which was regressed from reaeration data measured in streams throughout Texas. Reaeration is measured in the field using krypton-tritium radiotracer techniques. The Texas equation for reaeration is, specifically:

$$K_2 \text{ at } 20^\circ \text{C} = \frac{1.923V^{0.273}}{D^{0.894}} \quad [V-9]$$

Photosynthetic Reaeration

This type of reaeration occurs as a result of the photosynthesis/respiration cycles of aquatic plantlife. Over a diurnal period, photosynthesis produces oxygen and respiration consumes oxygen. The net effect over a daily period is assumed to be a dissolved oxygen source. In the QUAL-TX model, when algae and macrophyte growth are not being simulated, this DO source is expressed through the use of algae or macrophyte water column concentrations in the initial conditions specifications.

Temperature

Water temperature directly affects the rate at which decay and other processes take place. For example, the rate at which bacteria consume oxygen while decaying ammonia nitrogen slows significantly at colder temperatures. In order to take this into account, all rates are input at 20°C values and corrected to actual temperatures internally. This temperature correction is in the form of:

$$K_2 \text{ at temp } T^\circ\text{C} = K_2 \text{ at } 20^\circ\text{C } q^{(T-20)} \quad [V-10]$$

Theta values have been determined experimentally for each rate.

V.B.2.e QUAL-TX Input Requirements

In order to perform a QUAL-TX model simulation, data collected for a stream must be reduced to the appropriate format. First, the segmentation of the stream is used to describe each reach. This is input into the model as beginning and ending stream distances, as well as the length of each element within the reach. Hydraulic equations must also be specified for each reach. Using measured time-of-travel data in conjunction with average flows, widths and depths of the time-of-travel reach, the coefficients of the hydraulic equations can be calculated. Ideally, hydraulic information would be available for all reaches in a system; however, this is not generally the case. In addition to these requirements, headwater and wasteload flows and associated quality must be available for major sources. Because QUAL-TX simulates a diurnal average, diurnal data, which include dissolved oxygen and temperature, are collected. Samples analyzed by a laboratory are composited over a diurnal period and result in BOD, nitrogen series, phosphorus and conservative water quality constituents. For each complete set of data, a flow balance is used

V.B.3 Existing Wasteload Evaluation

The Texas Water Commission Water Quality Assessment Unit performed a wasteload evaluation (WLE) for the San Gabriel/North Fork San Gabriel River, Segment 1248, in 1985 and 1986. A DRAFT of that evaluation was published on March 16, 1987. A final report has not been adopted by the TWC. The TWC study focussed on existing permitted facilities or facilities with pending permits applications. In addition, the TWC study did not consider development scenarios beyond the proposed maximum lifetime capacities of existing facilities, e.g., the Georgetown facility was projected at a maximum discharge rate of 2.8 MGD for 2005. The discharge flows and treatment levels used in that study are shown in Table V.4.

As part of 1987 WLE, the TWC calibrated and validated the QUAL-TX Water Quality Simulation Model for Segment 1248 and its major tributaries using measured data collected on August 20, 1985 and September 26, 1979, respectively. The segmentation developed for the TWC WLE formed a basis for the segmentations used in this study. Examination of the calibration and validation simulation output demonstrated a reasonable fit with the empirical data.

The major conclusions of the TWC WLE are:

- "The ultimate permitted treatment level with a 4 mg/L effluent dissolved oxygen requirement for the Georgetown WWTP allows for maintenance of the dissolved oxygen criterion in the San Gabriel River at flows of 1.8 MGD or less under critical summer conditions and for flows greater than 1.8 MGD under critical non-summer low flow conditions.
- "At discharges greater than 1.8 MGD during critical summer months, the 5 mg/L criterion may be attained in the San Gabriel River with nitrification at the Georgetown WWTP."

The major recommendations of the TWC WLE are:

- "The City of Georgetown should meet effluent qualities of 10 mg/L BOD₅, 3 mg/L NH₃-N, and 4 mg/L DO during the summer months of May through September at discharges greater than 1.8 MGD. Otherwise, effluent qualities of 10 mg/L BOD₅, 15 mg/L NH₃-N, and 4 mg/L DO are required.
- "All other dischargers should retain their final permitted values. Where advanced secondary treatment is specified, a 4 mg/L dissolved oxygen concentration should be required.
- "Requests for discharges greater than those outlined in the projection will be considered on a case-by-case basis. New dischargers to the segment should be commensurate with those considered in this wasteload evaluation and will be considered on a case-by-case basis.

Table V.4
Existing, Projected, and Permitted Wastewater Loading to
Segment 1248 of the San Gabriel River^{a/}

Discharger name Permit No.	River Kilometer	Status	Flow (MGD)	BOD ₅ (mg/L)	NH ₃ -N (mg/L)	DO (mg/L)	BOD ₅ (lb/day)	NH ₃ -N (lb/day)
Georgetown (10489.002)	96.3	Existing (1988)	1.7000	2.3	15.0	5.0	32.4	212.7
		Projected (2005)	2.8000	10.0	3.0	4.0	233.5	70.1
		Permitted (final)	2.5000	10.0	15.0	2.0	208.5	312.8
SCB Development Company (12831.001)	89.7 (8.0)	Existing (1988)		No discharge				
		Projected (2005)	0.4000	10.0	15.0	4.0	33.4	50.0
		Permitted (final)	0.4000	10.0	15.0	2.0	33.4	50.0
168 Acre No Georgetown J V (13261.001 Pdg)	89.7 (15.8)	Existing (1988)		Not in existence				
		Projected (2005)	0.3250	10.0	3.0	4.0	27.1	8.1
		Pending permit	0.3250	10.0	3.0	4.0	27.1	8.1
Pecan Branch Utility (13297.001 Pdg)	89.7	Existing (1988)		Not in existence				
		Projected (2005)	0.2000	10.0	3.0	4.0	16.7	5.0
		Pending permit	0.2000	10.0	3.0	4.0	16.7	5.0
Dove Springs Development Co. (13322.001)	84.2 (6.9)	Existing (1988)		Not in existence				
		Projected (2005)	1.0000	10.0	3.0	4.0	20.8	83.2
		Permitted (final)	0.2500	10.0	15.0	4.0	20.8	31.3

^{a/} Current use and projected permit conditions.

- "New effluent limitations as recommended in this wasteload evaluation shall be complied with no later than July 1, 1992, regardless of the availability of state and/or federal funds.
- "All existing permits should be amended to reflect the recommended effluent limitations and to include compliance schedules for meeting those limitations as soon as is determined practicable and feasible by the Texas Water Commission.
- "Regionalization of facilities is strongly encouraged to take advantage of economies of scale and improved operation and maintenance opportunities at larger facilities.
- "Existing uses, which have been identified and attained, must be maintained in accordance with existing statutes."

V.B.4 QUAL-TX Simulation Alternatives

The result of the screening analysis described in Section IV was the selection of four recommended locations for modeling analysis using the QUAL-TX Water Quality Simulation Program. The four sites chosen for modeling are:

- The City of Georgetown (G.T.) wastewater facility located along the San Gabriel River just downstream of the park road bridge, on the assumption that either a variance could be secured to TWC Rule 313 that would allow expansion of the existing facility, or that the effluent could be economically piped downstream, off of the Edwards recharge zone;
- Dove Springs Development Corporation (D.S.) located along an unnamed fork of Mankin's Branch Creek in the vicinity of CR 102;
- Mankin's Crossing (M.X.) at the San Gabriel River between State Highway 29 and the Mankin's Branch Creek confluence; and
- Berry Creek (B.C.) near the confluence of the San Gabriel River and Pecan Branch Creek.

In the selection of future development scenarios for simulation with QUAL-TX, the following facts are significant: (1) the City of Georgetown currently owns and operates a permitted 2.5 MGD facility with a treatment level of 10/15/2. This permit is likely to be renewable, at current levels, with the TWC for the foreseeable future and, if necessary, the City of Georgetown could increase the treatment levels of this facility to extend its useful life to the term of the planning horizon, and (2) the Dove Springs Development Corporation currently has a permit for 0.2 MGD at a treatment level of 10/15/4, with a proposed new application to the TWC to raise the discharge flow from this facility to 1.0 MGD.

The various combinations of sites selected for simulation with the QUAL-TX water quality model are listed in Table V.5. The simulation scenarios were developed under the assumption that, for the immediate future, the City of Georgetown will continue to utilize its existing 2.5 MGD treatment facility and that the Dove Springs Development Corporation permit will be issued for 1.0 MGD at a treatment level of 10/3/4. The simulation scenarios are described as follows:

- Scenario A (Figure V.3) assumes only the Georgetown facility under its currently permitted conditions (Aa1); under conditions with the current flow and conditions necessary to meet the dissolved oxygen criteria of the San Gabriel River-Segment 1248 (Aa2); and with an expansion of the facility to 4.0 MGD, with treatment levels of 10/3/4 and 5/2/5, respectively (Ab1 and Ab2).
- Scenario B1 (Figure V.4) assumes the existence of only the City of Georgetown facility and the proposed Dove Springs Development Corporation facility. Three simulation cases are considered. For the first case (B1a1) the City of Georgetown and Dove Springs Development Corporation discharges are assumed at their permitted or assumed permitted levels. The second case (B1a2) assumes that Georgetown is at its currently permitted level and the Dove Springs Development Corporation plant will be permitted for 2.4 MGD at a treatment level of 10/3/4. In the third case (B1a3) the Georgetown facility is upgraded to treat 2.5 MGD at a treatment level of 10/3/4 and the Dove Springs Development Corporation facility is permitted at 10/3/4 with a capacity of 2.4 MGD.
- Scenario B2 (Figure V.4) assumes that the City of Georgetown WWTP will be expanded to accommodate 4 MGD at a treatment level of 10/3/4 and the Dove Springs Development Corporation treatment facility will be designed to accommodate 1.2 MGD at 10/3/4 (B2a1) with a future expansion to 2.4 MGD at 10/3/4 (B2a2).
- Scenario C1 (Figure V.5) assumes that the Georgetown treatment plant operates at 2.5 MGD. Simulation case C1a1 assumes Georgetown at a treatment level of 10/15/2, Dove Springs Development Corporation at 10/3/4 with a capacity of 1 MGD and a new facility at the Mankin's Crossing site to accommodate 4.5 MGD at a treatment level of 10/3/4. Simulation case C1a2 assumes the Georgetown facility will be upgraded to a treatment level of 10/3/4 and the Dove Springs Development Corporation and Mankin's Crossing facility will operate as in scenario C1 (1.0 MGD and 4.5 MGD, respectively, with a 10/3/4). Simulation case C1a3 assume the City of Georgetown operates at 2.5 MGD with an upgraded treatment level of 10/3/4; Dove Springs Development Corporation plant will be expanded to 2.4 MGD at a treatment level of 10/3/4, and a Mankin's Crossing plant will be constructed to accommodate 3 MGD at a treatment level of 10/3/4.

- Scenario C2 (Figure V.5) assumes that the Georgetown plant will operate at a capacity of 4 MGD and all facilities will have a treatment level of 10/3/4. Simulation case C2a1 assumes a capacity of 1 MGD at the Dove Springs plant with a larger, 3 MGD plant to be constructed near Mankin's Crossing. In simulation case C2a2 the combined capacity of these two plants remains the same; however, the Dove Springs plant is expanded to 2.4 MGD and the Mankin's Crossing plant is constructed with a capacity of 1.6 MGD.
- Scenario D1 (Figure V.6) assumes that the Georgetown plant capacity remains at the current 2.5 MGD, the Dove Springs plant has a capacity of 1.0 MGD and two additional treatment plants are considered. The Mankin's Crossing plant is constructed at a capacity of 2.5 MGD and a fourth plant is constructed at Berry Creek with a capacity of 2 MGD. For simulation case D1a1 the Georgetown plant stays at its present treatment level of 10/15/2, with an upgrade to 10/3/4 for scenario D1a2. The other three plants are all assumed at a treatment level of 10/3/4 for both cases.
- Scenario D2 (Figure V.6) assumes an upgrading of the Georgetown plant to 4 MGD with a treatment levels of 10/3/4. The Dove Springs and Berry Creek plants are included with varying capacities (totalling 4 MGD) at a treatment level of 10/3/4. Simulation case D2a1 assumes Dove Springs has a capacity of 1 MGD and Berry Creek has a capacity of 3 MGD. Simulation case D2a2 assumes the Dove Springs capacity increases to 2.4 MGD and that the Berry Creek capacity is reduced to 1.6 MGD.
- Scenario E (Figure V.7) considers one large, 7 MGD plant at Berry Creek. Simulation case E1 is at a treatment level of 10/3/4 and in E2 the treatment level is increased to 5/2/5.
- Scenario F (Figure V.7) considers one large, 8 MGD plant at Mankin's Crossing. Simulation case F1 is at a treatment level of 10/3/4 and in F2 the treatment level is increased to 5/2/5.
- Scenario G (Figure V.8) eliminates the plant at Dove Springs and allocates 2 MGD to Berry Creek and 3.5 MGD to Mankin's Crossing. The Georgetown plant remains at 2.5 MGD. All plants operate at a treatment level of 10/3/4.
- Scenario H (Figure V.9) assumes two plants, the existing Georgetown plant (at 2.5 MGD) and an additional plant at Mankin's Crossing with a capacity of 5.5 MGD. Both have a treatment level of 10/3/4.

**Table V.5
QUAL-TX San Gabriel River Simulation Scenarios**

Scenario	Case	Facility	Discharge Rate (MGD)	Treatment Level (BOD ₅ /NH ₃ /DO _{eff.})	Total Discharge (MGD)
A	Aa1	Georgetown	2.5	10/15/2	2.5
	Aa2	Georgetown	2.5	10/3/4	2.5
	Ab1	Georgetown	4.0	10/3/4	4.0
	Ab2	Georgetown	4.0	5/2/5	4.0
B1	B1a1	Georgetown	2.5	10/15/2	3.5
		Dove Springs Dev.	1.0	10/15/4	
	B1a2	Georgetown	2.5	10/15/2	4.9
		Dove Springs Dev.	2.4	10/3/4	
	B1a3	Georgetown	2.5	10/3/4	4.9
		Dove Springs Dev.	2.4	10/3/4	
B2	B2a1	Georgetown	4.0	10/3/4	5.2
		Dove Springs Dev.	1.2	10/3/4	
	B2a2	Georgetown	4.0	10/3/4	6.4
		Dove Springs Dev.	2.4	10/3/4	
C1	C1a1	Georgetown	2.5	10/15/2	8.0
		Dove Springs Dev.	1.0	10/3/4	
		Mankin's Crossing	4.5	10/3/4	
	C1a2	Georgetown	2.5	10/3/4	8.0
		Dove Springs Dev.	1.0	10/3/4	
		Mankin's Crossing	4.5	10/3/4	
	C1a3	Georgetown	2.5	10/3/4	7.9
		Dove Springs Dev.	2.4	10/3/4	
		Mankin's Crossing	3.0	10/3/4	
C2	C2a1	Georgetown	4.0	10/3/4	8.0
		Dove Springs Dev.	1.0	10/3/4	
		Mankin's Crossing	3.0	10/3/4	
	C2a2	Georgetown	4.0	10/3/4	8.0
		Dove Springs Dev.	2.4	10/3/4	
		Mankin's Crossing	1.6	10/3/4	
D1	D1a1	Georgetown	2.5	10/15/2	8.0
		Dove Springs Dev.	1.0	10/3/4	
		Berry Creek	2.0	10/3/4	
		Mankin's Crossing	2.5	10/3/4	
	D1a2	Georgetown	2.5	10/3/4	8.0
		Dove Springs Dev.	1.0	10/3/4	
		Berry Creek	2.0	10/3/4	
		Mankin's Crossing	2.5	10/3/4	
D2	D2a1	Georgetown	4.0	10/3/4	8.0
		Dove Springs Dev.	1.0	10/3/4	
		Berry Creek	3.0	10/3/4	
	D2a2	Georgetown	4.0	10/3/4	8.0
		Dove Springs Dev.	2.4	10/3/4	
		Berry Creek	1.6	10/3/4	
E	E1	Berry Creek	7.0	10/3/4	7.0
	E2	Berry Creek	7.0	5/2/5	7.0
F	F1	Mankin's Crossing	8.0	10/3/4	8.0
	F2	Mankin's Crossing	8.0	5/2/5	8.0
G	G1	Georgetown	2.5	10/3/4	8.0
		Berry Creek	2.0	10/3/4	
		Mankin's Crossing	3.5	10/3/4	
H	H1	Georgetown	2.5	10/3/4	8.0
		Mankin's Crossing	5.5	10/2/6	

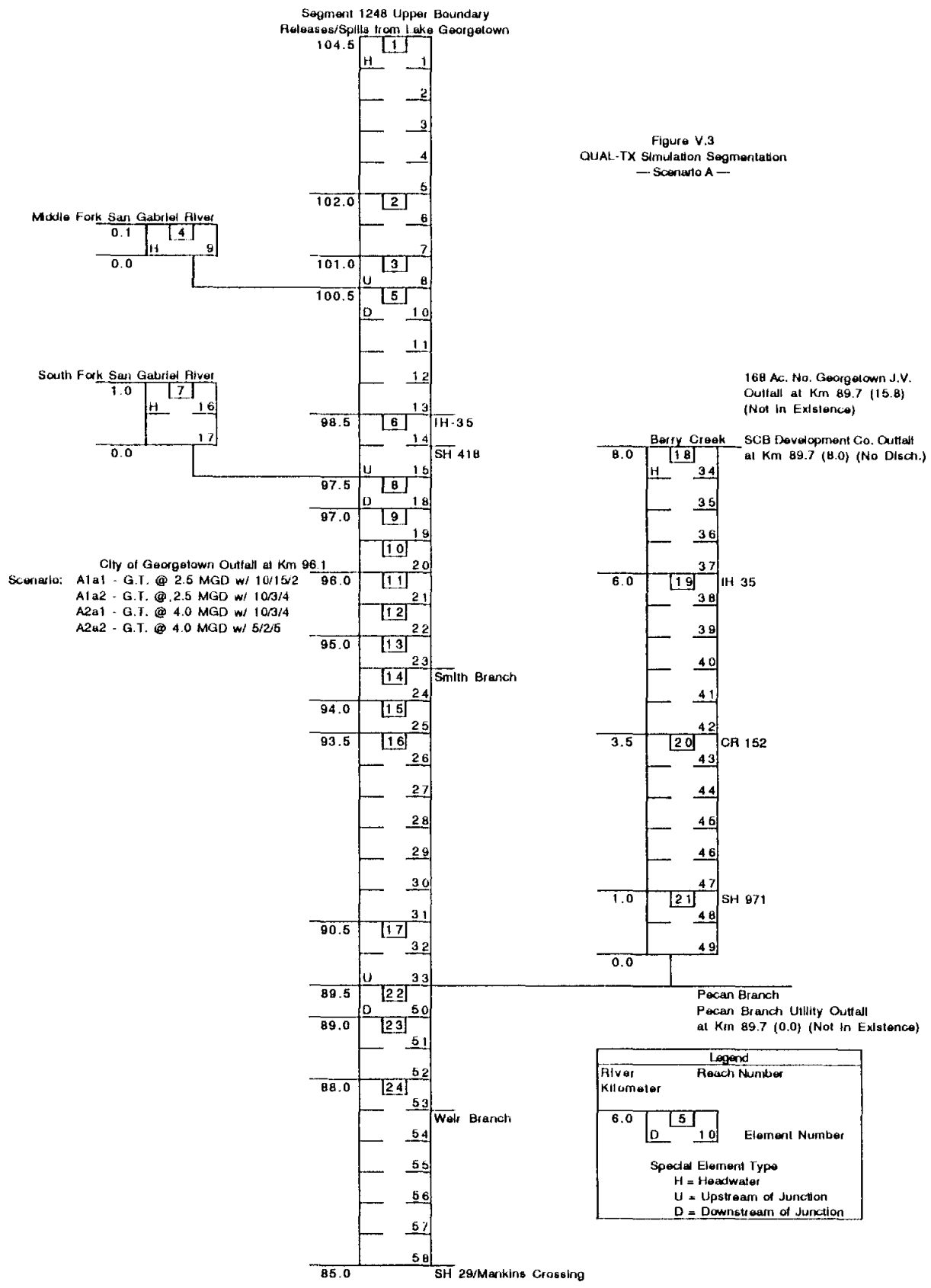

Figure V.3
QUAL-TX Simulation Segmentation
— Scenario A —

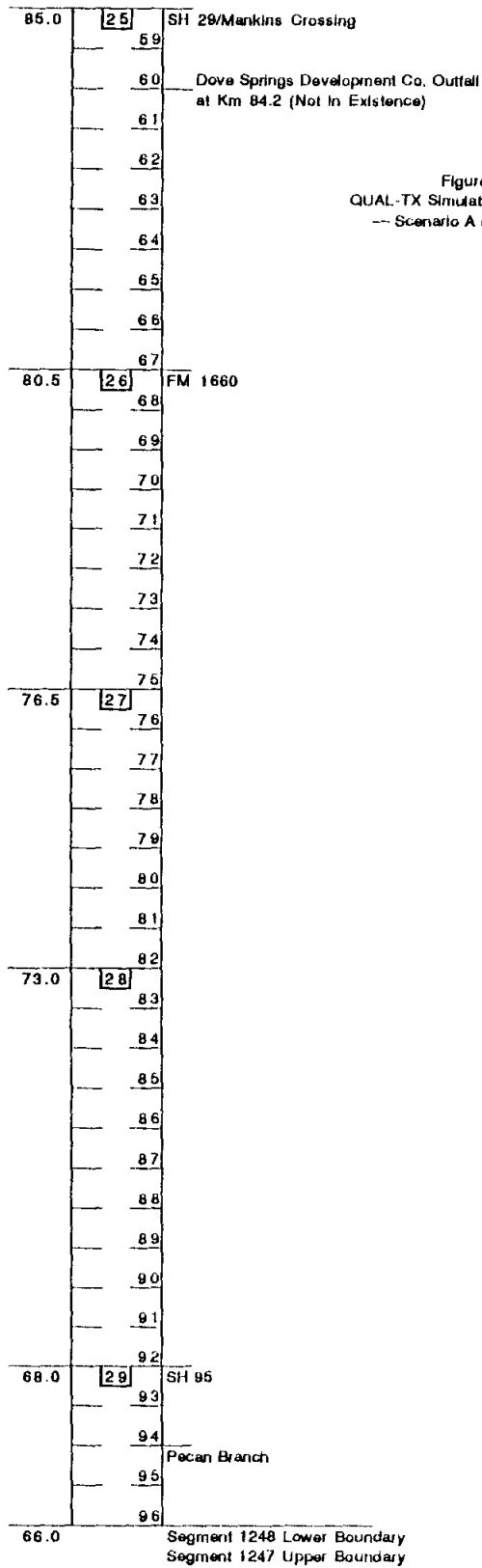
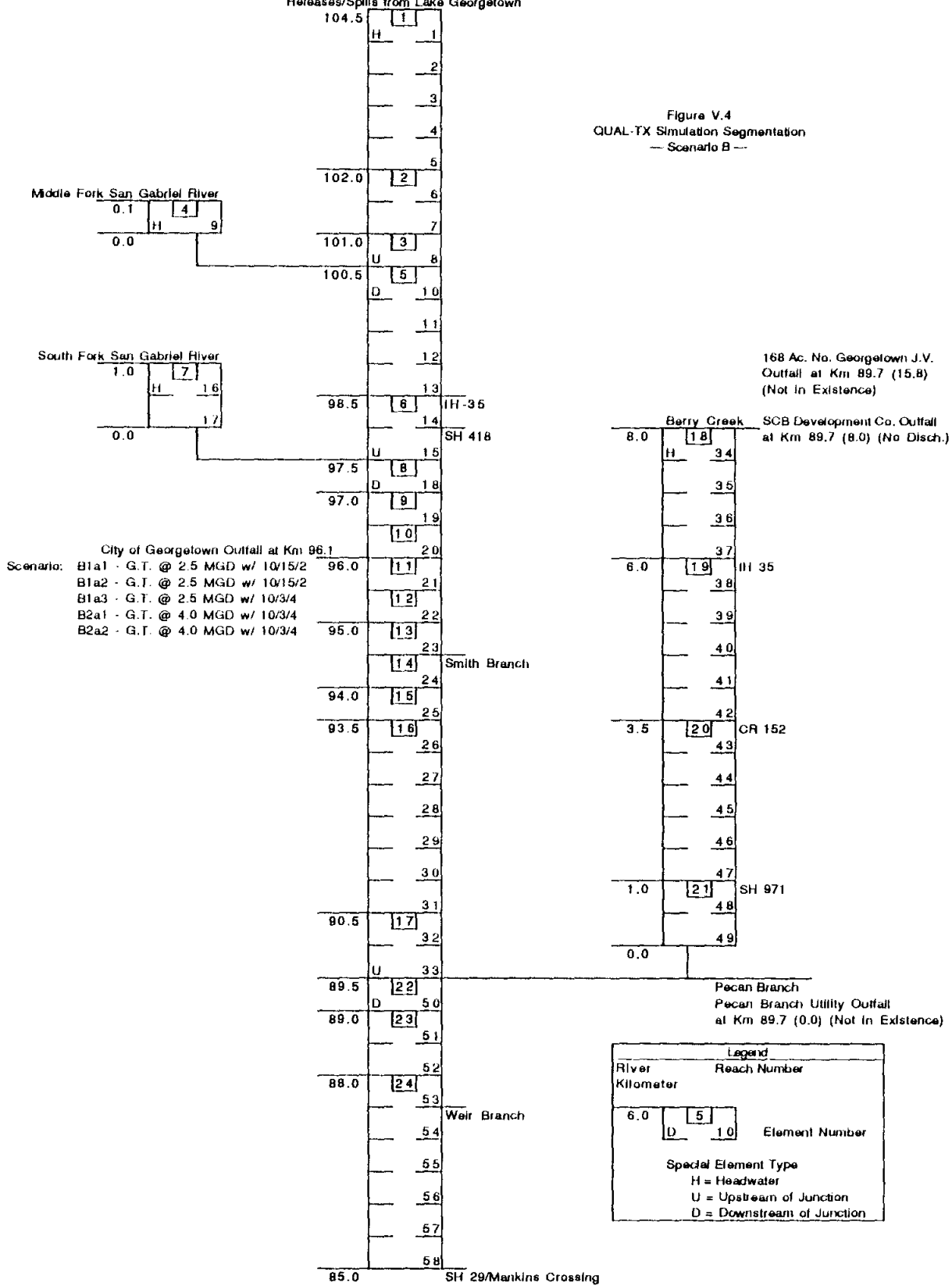

Figure V.3
 QUAL-TX Simulation Segmentation
 -- Scenario A (Continued) --

Segment 1248 Upper Boundary
Releases/Spills from Lake Georgetown



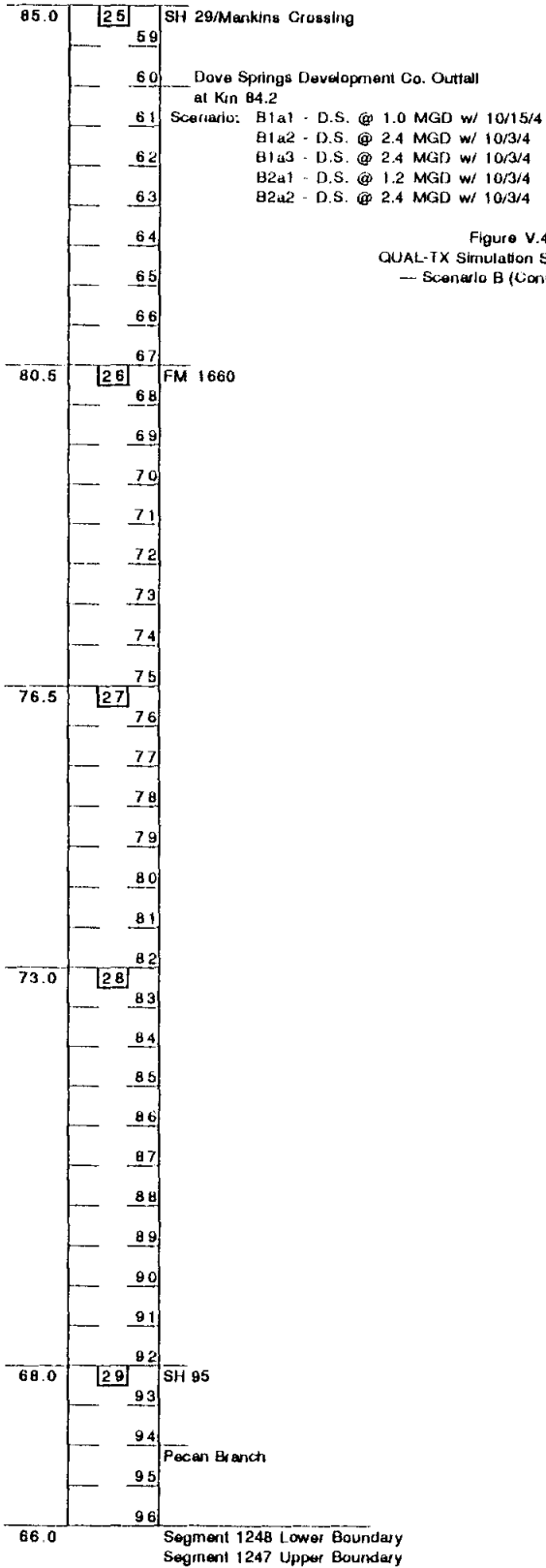
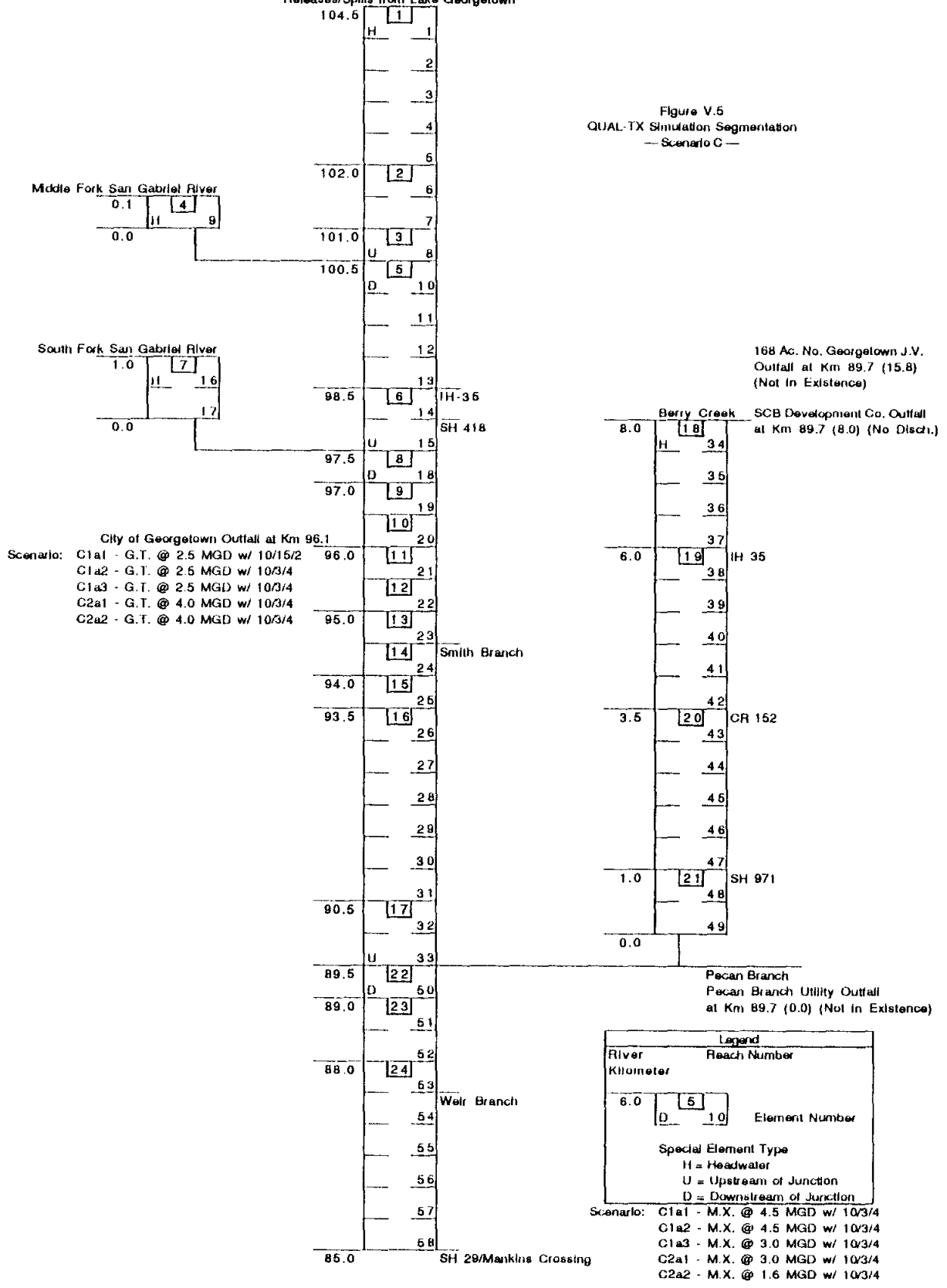

Figure V.4
 QUAL-TX Simulation Segmentation
 — Scenario B (Continued) —

Segment 1248 Upper Boundary
Releases/Spills from Lake Georgetown



Scenario: C1a1 - M.X. @ 4.5 MGD w/ 10/3/4
 C1a2 - M.X. @ 4.5 MGD w/ 10/3/4
 C1a3 - M.X. @ 3.0 MGD w/ 10/3/4
 C2a1 - M.X. @ 3.0 MGD w/ 10/3/4
 C2a2 - M.X. @ 1.6 MGD w/ 10/3/4

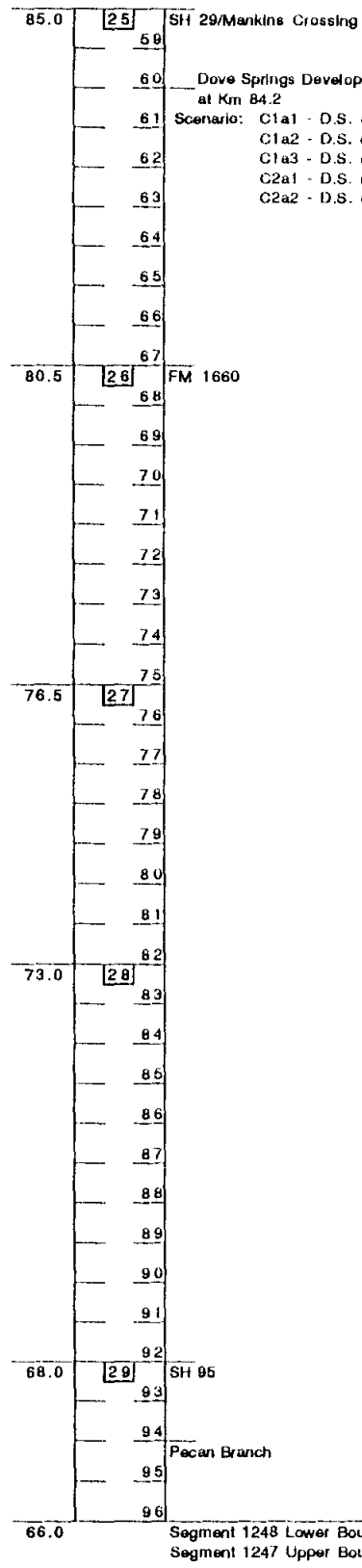
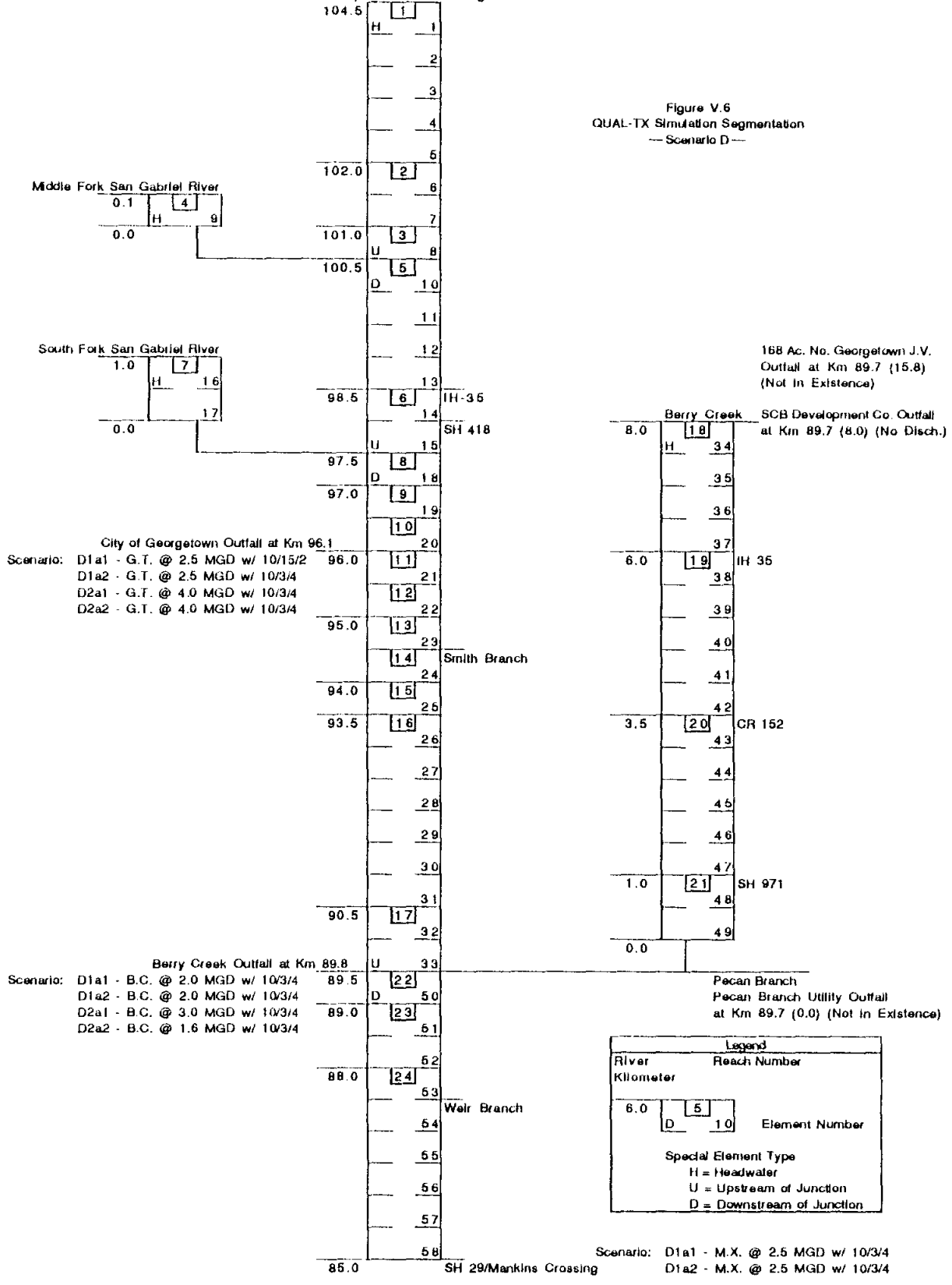

Figure V.5
 QUAL-TX Simulation Segmentation
 --- Scenario C (Continued) ---

Segment 1248 Upper Boundary
Releases/Spills from Lake Georgetown



Scenario: D1a1 - M.X. @ 2.5 MGD w/ 10/3/4
 D1a2 - M.X. @ 2.5 MGD w/ 10/3/4

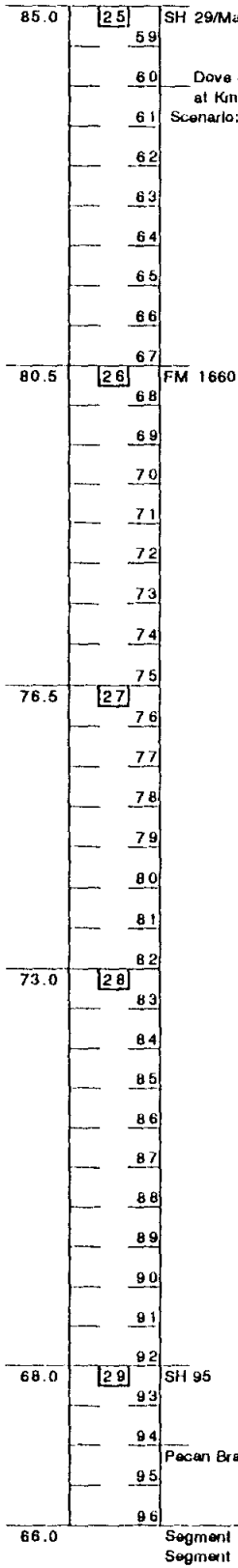
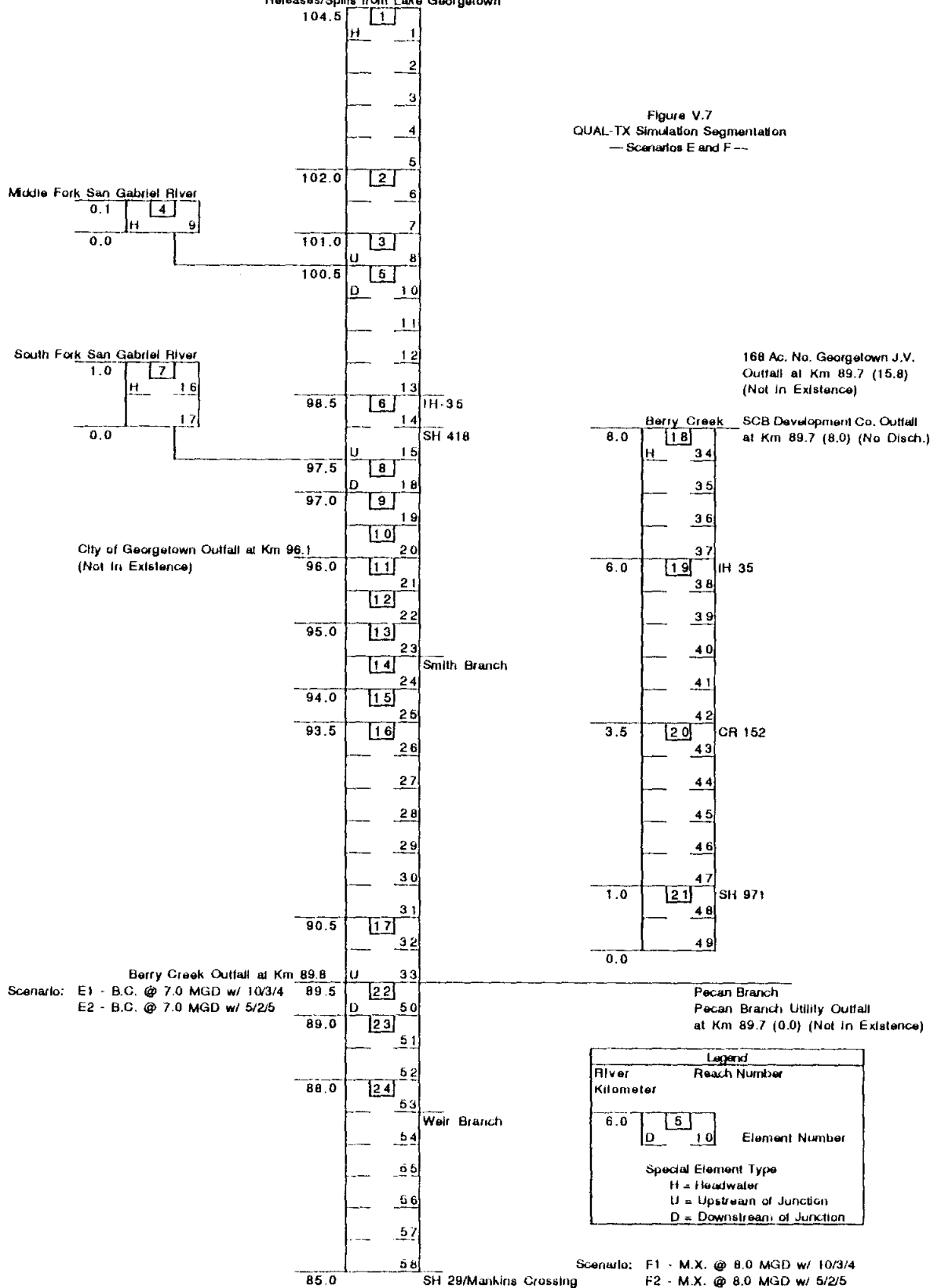

Figure V.6
 QUAL-TX Simulation Segmentation
 — Scenario D (Continued) —

Segment 1248 Upper Boundary
Releases/Spills from Lake Georgetown



Scenario: F1 - M.X. @ 8.0 MGD w/ 10/3/4
 F2 - M.X. @ 8.0 MGD w/ 5/2/5

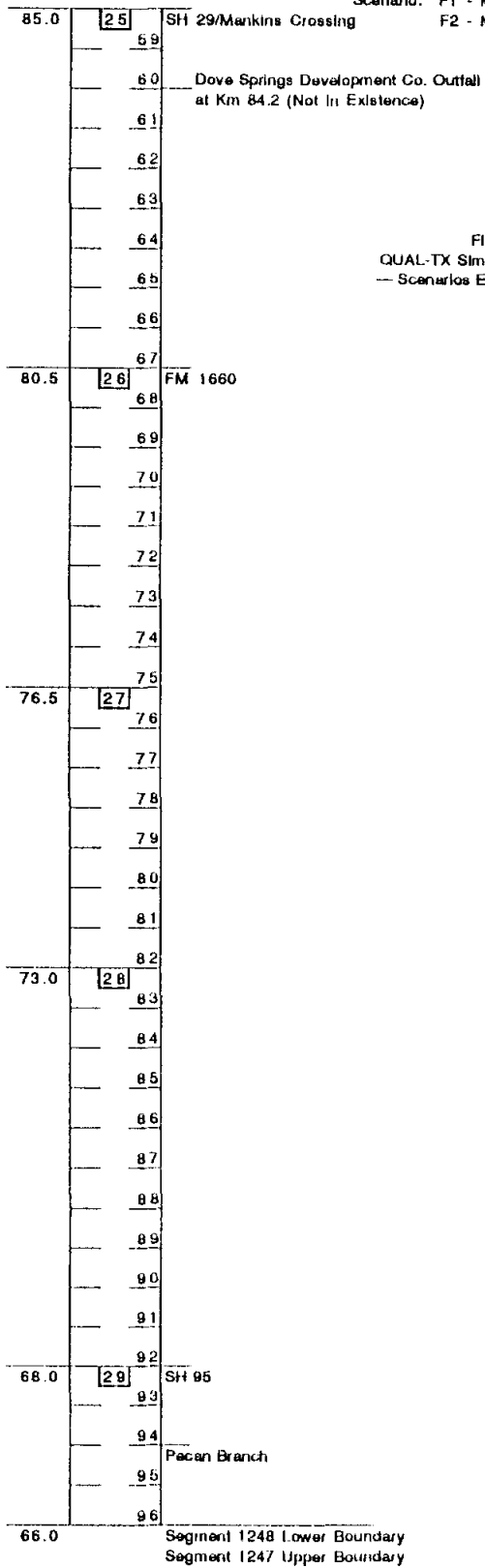
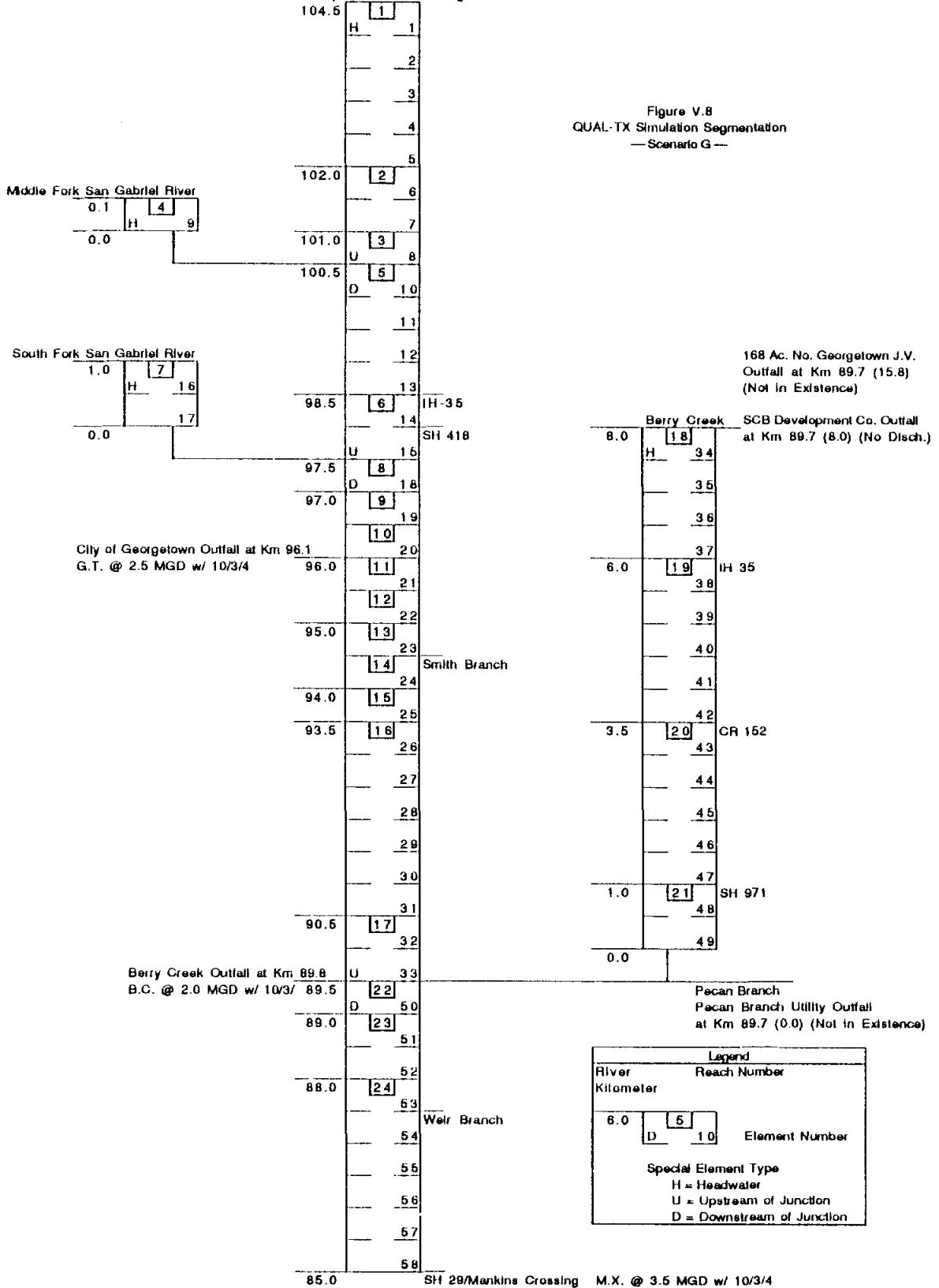

Figure V.7
 QUAL-TX Simulation Segmentation
 — Scenarios E and F (Continued) —

Segment 1248 Upper Boundary
Releases/Splits from Lake Georgetown



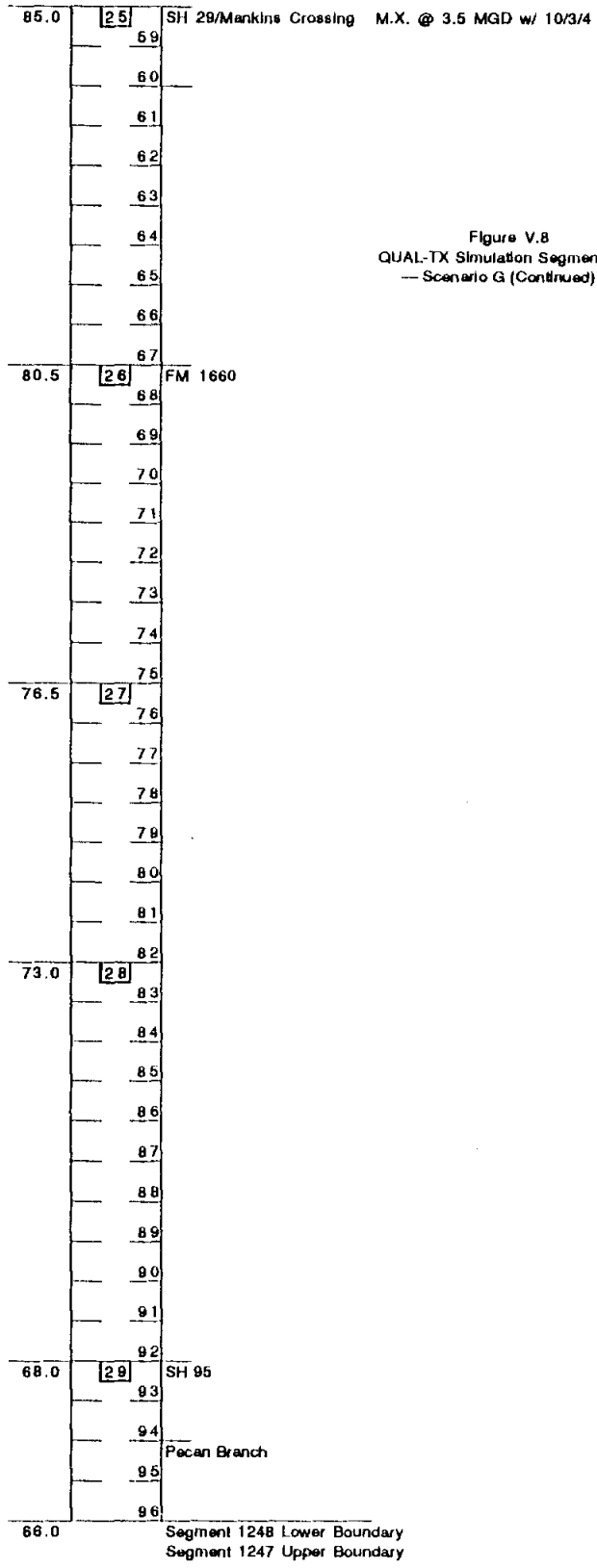
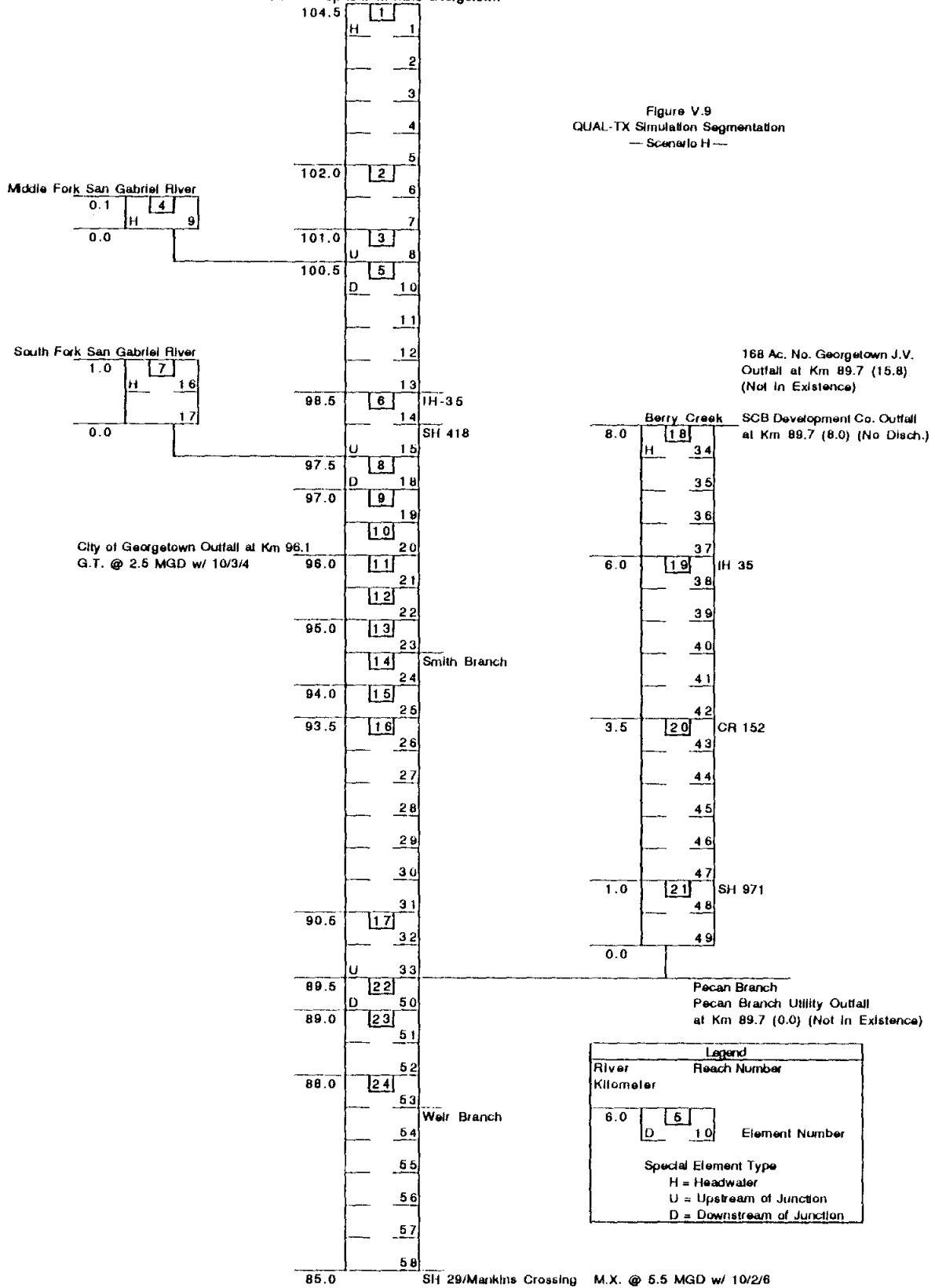

Figure V.8
 QUAL-TX Simulation Segmentation
 --- Scenario G (Continued) ---

Segment 1248 Upper Boundary
Releases/Spills from Lake Georgetown



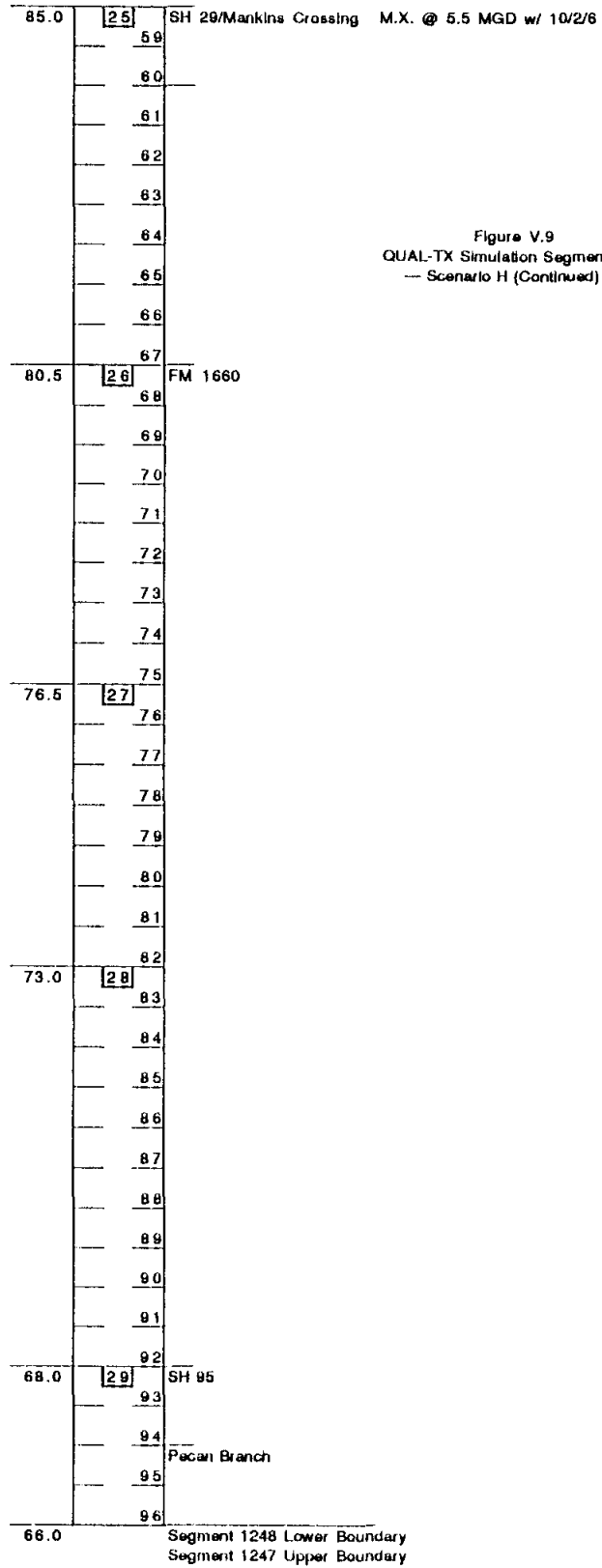

Figure V.9
 QUAL-TX Simulation Segmentation
 -- Scenario H (Continued) --

V.B.5 Simulation Results

Scenario A simulation results (Table V.6 and Figure V.10) show that the current Georgetown wastewater treatment facility, operating at currently permitted flow and treatment levels under critical summer low flow and temperature conditions, cannot maintain the TWC prescribed minimum dissolved oxygen level of 5 mg/L in the San Gabriel River downstream of its outfall. The minimum dissolved oxygen concentration predicted as a result of the Georgetown wastewater discharge is 4.3 mg/L. In addition, the dissolved oxygen sag remains below 5.0 mg/L for at least 7 kilometers (4.4 miles) downstream of the outfall. Increasing the Georgetown plant treatment level to 10/3/4 results in minimum DO levels greater than 5.5 mg/L downstream of its outfall, well above the State's minimum criteria. In addition, at a treatment level of 10/3/4 the City of Georgetown could discharge to the San Gabriel River 4.0 MGD and maintain a minimum DO level of 5.2 mg/L.

Scenario B1 (Table V.7 and Figure V.11) also shows, that at currently permitted levels, the City of Georgetown violates the State's minimum dissolved oxygen concentration of 5.0 downstream of its outfall. However, the addition of the Dove Springs Development Corporation discharge at either 1.0 MGD or 2.4 MGD with treatment levels of 10/15/4 or 10/3/4 does not sufficiently depress DO concentrations to violate the State criteria.

Scenario B2 (Table V.8 and Figure V.12) does not demonstrate any violations of the states minimum dissolved oxygen criteria for the San Gabriel River Segment 1248. Increasing the Dove Springs Development Corporation effluent flow from 1.2 to 2.4 MGD does not significantly depress dissolved oxygen levels. The likely reason for this minor impact is a combination of the dilution supplied by the background flow of the San Gabriel River flow and the Georgetown discharge ($Q_{total} = 10.3$ MGD) which has recovered to a dissolved oxygen level of approximately 6.4 mg/L prior to the Dove Springs Development Corporation release.

Scenario C1 (Table V.9 and Figure V.13) demonstrates the compound effects of the Dove Springs Development Corporation outfall and a facility built near the confluence of the San Gabriel River with Mankin's Branch Creek. Because of the close proximity of the confluence of Mankin's Branch Creek, the receiving stream for the Dove Springs Development Corporation outfall, and the likely location of a Mankin's Crossing facility, the combined impact of the two outfalls becomes significant. Under this development scenario it would be necessary for the City of Georgetown to increase treatment levels to 10/3/4 to allow the Dove Springs Development Corporation to increase their flow to 2.4 MGD. The Mankin's Crossing plant would be limited to 3.0 MGD at a treatment level of 10/3/4 in order to preclude violation of the State's water quality standards. If higher flow rates are desired at either the Dove Springs or Mankin's Crossing plants a treatment level of 5/2/5 would be necessary.

Table V.6
Simulation Scenario A - DO, BOD, and NH3 Concentrations ^{a/}

River Km	Flow, cms	Simulation Scenario A1a1			Simulation Scenario A1a2			Simulation Scenario A1b1			Simulation Scenario A1b2		
		DO, mg/L	BOD, mg/L	NH3, mg/L	DO, mg/L	BOD, mg/L	NH3, mg/L	DO, mg/L	BOD, mg/L	NH3, mg/L	DO, mg/L	BOD, mg/L	NH3, mg/L
104.0	0.007	6.6	0.6	0.2	6.6	0.6	0.2	6.6	0.6	0.2	6.6	0.6	0.2
103.5	0.007	6.8	0.4	0.2	6.8	0.4	0.2	6.8	0.4	0.2	6.8	0.4	0.2
103.0	0.007	6.9	0.3	0.2	6.9	0.3	0.2	6.9	0.3	0.2	6.9	0.3	0.2
102.5	0.007	7.0	0.4	0.1	7.0	0.4	0.1	7.0	0.4	0.1	7.0	0.4	0.1
102.0	0.007	7.0	0.4	0.1	7.0	0.4	0.1	7.0	0.4	0.1	7.0	0.4	0.1
101.5	0.007	7.1	0.4	0.0	7.1	0.4	0.0	7.1	0.4	0.0	7.1	0.4	0.0
101.0	0.007	7.1	0.5	0.0	7.1	0.5	0.0	7.1	0.5	0.0	7.1	0.5	0.0
100.5	0.007	7.1	0.5	0.0	7.1	0.5	0.0	7.1	0.5	0.0	7.1	0.5	0.0
100.0	0.047	6.5	1.0	0.1	6.5	1.0	0.1	6.5	1.0	0.1	6.5	1.0	0.1
99.5	0.070	6.5	1.0	0.2	6.5	1.0	0.2	6.5	1.0	0.2	6.5	1.0	0.2
99.0	0.094	6.6	0.9	0.2	6.6	0.9	0.2	6.6	0.9	0.2	6.6	0.9	0.2
98.5	0.117	6.6	0.9	0.2	6.6	0.9	0.2	6.6	0.9	0.2	6.6	0.9	0.2
98.0	0.141	6.6	0.9	0.2	6.6	0.9	0.2	6.6	0.9	0.2	6.6	0.9	0.2
97.5	0.164	6.6	0.8	0.2	6.6	0.8	0.2	6.6	0.8	0.2	6.6	0.8	0.2
97.0	0.197	6.6	0.7	0.2	6.6	0.7	0.2	6.6	0.7	0.2	6.6	0.7	0.2
96.5	0.221	6.6	0.6	0.2	6.6	0.6	0.2	6.6	0.6	0.2	6.6	0.6	0.2
96.0	0.343	5.1	3.6	4.9	5.8	3.6	1.1	5.5	4.6	1.4	6.0	2.6	1.0
95.5	0.343	4.6	3.3	4.6	5.6	3.3	1.1	5.2	4.3	1.4	5.9	2.5	1.0
95.0	0.343	4.5	3.1	4.5	5.6	3.1	1.1	5.2	4.0	1.4	6.0	2.3	1.0
94.5	0.343	4.5	2.8	4.4	5.7	2.8	1.1	5.2	3.7	1.4	6.0	2.1	1.1
94.0	0.343	4.3	2.8	4.2	5.6	2.8	1.1	5.2	3.7	1.4	6.0	2.2	1.0
93.5	0.343	4.4	2.7	4.1	5.7	2.7	1.1	5.2	3.5	1.4	6.0	2.1	1.0
93.0	0.343	4.5	2.5	3.9	5.8	2.5	1.1	5.3	3.3	1.4	6.0	2.0	1.0
92.5	0.343	4.6	2.4	3.8	5.8	2.4	1.1	5.4	3.1	1.3	6.1	1.9	1.0
92.0	0.343	4.6	2.2	3.7	5.9	2.2	1.0	5.4	3.0	1.3	6.1	1.8	1.0
91.5	0.343	4.7	2.1	3.5	6.0	2.1	1.0	5.5	2.8	1.3	6.2	1.7	1.0
91.0	0.343	4.8	2.0	3.4	6.0	2.0	1.0	5.6	2.7	1.3	6.2	1.7	1.0
90.5	0.343	4.9	1.9	3.3	6.1	1.9	1.0	5.6	2.5	1.2	6.3	1.6	1.0
90.0	0.343	4.6	1.6	3.0	6.0	1.6	0.9	5.5	2.2	1.2	6.1	1.4	0.9
89.5	0.343	4.6	1.4	2.7	6.0	1.4	0.8	5.5	2.0	1.1	6.1	1.2	0.9
89.0	0.361	4.7	1.3	2.3	6.0	1.3	0.7	5.5	1.7	1.0	6.1	1.1	0.8
88.5	0.374	4.9	1.2	2.0	6.1	1.2	0.6	5.6	1.6	0.9	6.2	1.0	0.7
88.0	0.388	5.0	1.1	1.8	6.2	1.1	0.6	5.7	1.4	0.8	6.2	1.0	0.6
87.5	0.388	5.2	1.0	1.6	6.3	1.0	0.5	5.8	1.3	0.7	6.3	0.9	0.6
87.0	0.388	5.4	0.9	1.4	6.4	0.9	0.5	6.0	1.2	0.7	6.3	0.9	0.6
86.5	0.388	5.5	0.8	1.3	6.4	0.8	0.4	6.1	1.1	0.6	6.4	0.8	0.5
86.0	0.388	5.7	0.8	1.2	6.5	0.8	0.4	6.2	1.0	0.6	6.5	0.8	0.5
85.5	0.388	5.8	0.7	1.1	6.6	0.7	0.4	6.3	1.0	0.5	6.5	0.7	0.4
85.0	0.388	6.0	0.7	1.0	6.7	0.7	0.3	6.3	0.9	0.5	6.6	0.7	0.4
84.5	0.388	6.1	0.7	0.9	6.7	0.7	0.3	6.4	0.8	0.4	6.7	0.6	0.4
84.0	0.388	6.2	0.6	0.8	6.8	0.6	0.3	6.5	0.8	0.4	6.7	0.6	0.3
83.5	0.388	6.3	0.6	0.7	6.8	0.6	0.2	6.6	0.8	0.4	6.8	0.6	0.3
83.0	0.388	6.4	0.6	0.6	6.9	0.6	0.2	6.6	0.7	0.3	6.8	0.6	0.3
82.5	0.388	6.5	0.6	0.6	6.9	0.6	0.2	6.7	0.7	0.3	6.9	0.6	0.3
82.0	0.388	6.6	0.5	0.5	6.9	0.5	0.2	6.8	0.6	0.3	6.9	0.5	0.2
81.5	0.388	6.6	0.5	0.4	7.0	0.5	0.2	6.8	0.6	0.3	6.9	0.5	0.2
81.0	0.388	6.7	0.5	0.4	7.0	0.5	0.1	6.9	0.6	0.2	7.0	0.5	0.2
80.5	0.388	6.8	0.5	0.3	7.0	0.5	0.1	6.9	0.6	0.2	7.0	0.5	0.2
80.0	0.388	6.8	0.5	0.3	7.1	0.5	0.1	6.9	0.5	0.2	7.0	0.5	0.2
79.5	0.388	6.9	0.5	0.3	7.1	0.5	0.1	7.0	0.5	0.2	7.1	0.5	0.1
79.0	0.388	6.9	0.5	0.2	7.1	0.5	0.1	7.0	0.5	0.1	7.1	0.5	0.1
78.5	0.388	7.0	0.4	0.2	7.1	0.4	0.1	7.0	0.5	0.1	7.1	0.5	0.1
78.0	0.388	7.0	0.4	0.2	7.1	0.4	0.1	7.1	0.5	0.1	7.1	0.4	0.1
77.5	0.388	7.0	0.4	0.2	7.2	0.4	0.0	7.1	0.5	0.1	7.1	0.4	0.1
77.0	0.388	7.1	0.4	0.1	7.2	0.4	0.0	7.1	0.5	0.1	7.2	0.4	0.1
76.5	0.388	7.1	0.4	0.1	7.2	0.4	0.0	7.1	0.5	0.1	7.2	0.4	0.1
76.0	0.388	7.1	0.4	0.1	7.2	0.4	0.0	7.1	0.5	0.1	7.2	0.4	0.1
75.5	0.388	7.1	0.4	0.1	7.2	0.4	0.0	7.2	0.4	0.1	7.2	0.4	0.0
75.0	0.388	7.1	0.4	0.1	7.2	0.4	0.0	7.2	0.4	0.0	7.2	0.4	0.0
74.5	0.388	7.2	0.4	0.1	7.2	0.4	0.0	7.2	0.4	0.0	7.2	0.4	0.0
74.0	0.388	7.2	0.4	0.0	7.2	0.4	0.0	7.2	0.4	0.0	7.2	0.4	0.0
73.5	0.388	7.2	0.4	0.0	7.2	0.4	0.0	7.2	0.4	0.0	7.2	0.4	0.0
73.0	0.388	7.2	0.4	0.0	7.2	0.4	0.0	7.2	0.4	0.0	7.2	0.4	0.0
72.5	0.388	7.2	0.4	0.0	7.2	0.4	0.0	7.2	0.4	0.0	7.3	0.4	0.0
72.0	0.388	7.2	0.4	0.0	7.2	0.4	0.0	7.2	0.4	0.0	7.3	0.4	0.0
71.5	0.388	7.2	0.4	0.0	7.3	0.4	0.0	7.3	0.4	0.0	7.3	0.4	0.0
71.0	0.388	7.2	0.4	0.0	7.3	0.4	0.0	7.3	0.4	0.0	7.3	0.4	0.0
70.5	0.388	7.2	0.4	0.0	7.3	0.4	0.0	7.3	0.4	0.0	7.3	0.4	0.0
70.0	0.388	7.2	0.4	0.0	7.3	0.4	0.0	7.3	0.4	0.0	7.3	0.4	0.0
69.5	0.388	7.3	0.4	0.0	7.3	0.4	0.0	7.3	0.4	0.0	7.3	0.4	0.0
69.0	0.388	7.3	0.4	0.0	7.3	0.4	0.0	7.3	0.4	0.0	7.3	0.4	0.0
68.5	0.388	7.3	0.4	0.0	7.3	0.4	0.0	7.3	0.4	0.0	7.3	0.4	0.0
68.0	0.388	7.3	0.4	0.0	7.3	0.4	0.0	7.3	0.4	0.0	7.3	0.4	0.0
67.5	0.388	7.3	0.4	0.0	7.3	0.4	0.0	7.3	0.4	0.0	7.3	0.4	0.0
67.0	0.388	7.3	0.4	0.0	7.3	0.4	0.0	7.3	0.4	0.0	7.3	0.4	0.0
66.5	0.388	7.3	0.4	0.0	7.3	0.4	0.0	7.3	0.4	0.0	7.3	0.4	0.0
66.0	0.388	7.3	0.4	0.0	7.3	0.4	0.0	7.3	0.4	0.0	7.3	0.4	0.0

^{a/} Scenario A1 - City of Georgetown Plant Only

A1a1 - G.T. @ 2.5 MGD w/ 10/15/2

A1a2 - G.T. @ 2.5 MGD w/ 10/3/4

A1b1 - G.T. @ 4.0 MGD w/ 10/3/4

A1b2 - G.T. @ 4.0 MGD w/ 5/2/5

Figure V.10
 San Gabriel River - Segment 1248
 Dissolved Oxygen Concentrations Assuming
 City of Georgetown WWTP Only
 — Scenario A —

V-38

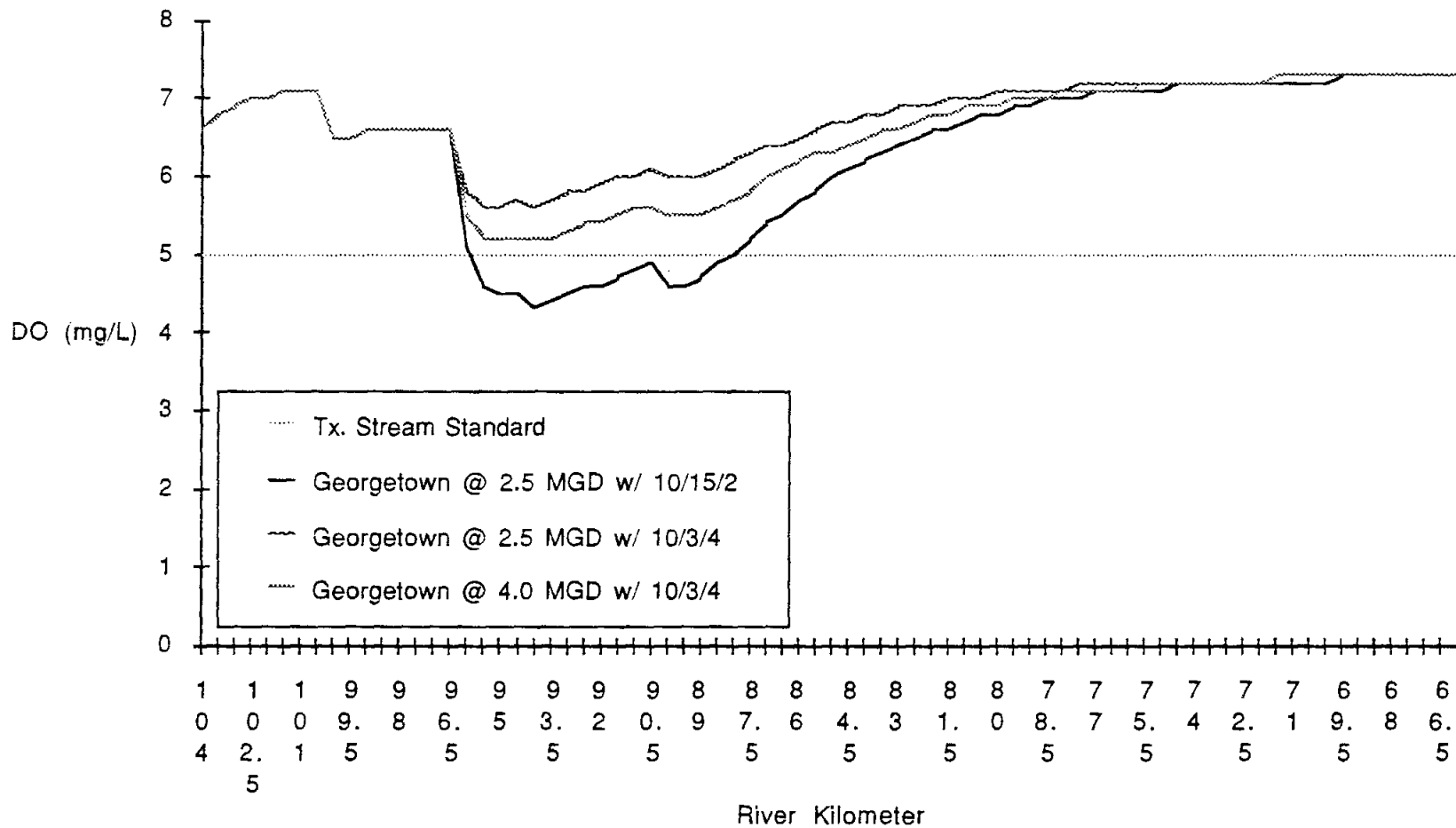

Table V.7
Simulation Scenario B1 - DO, BOD, and NH3 Concentrations ^{a/}

River Km	Flow, cms	Simulation Scenario B1a1			Simulation Scenario B1a2			Simulation Scenario B1a3		
		DO, mg/L	BOD, mg/L	NH3, mg/L	DO, mg/L	BOD, mg/L	NH3, mg/L	DO, mg/L	BOD, mg/L	NH3, mg/L
104.0	0.007	6.6	0.6	0.2	6.6	0.6	0.2	6.6	0.6	0.2
103.5	0.007	6.8	0.4	0.2	6.8	0.4	0.2	6.8	0.4	0.2
103.0	0.007	6.9	0.3	0.2	6.9	0.3	0.2	6.9	0.3	0.2
102.5	0.007	7.0	0.4	0.1	7.0	0.4	0.1	7.0	0.4	0.1
102.0	0.007	7.0	0.4	0.1	7.0	0.4	0.1	7.0	0.4	0.1
101.5	0.007	7.1	0.4	0.0	7.1	0.4	0.0	7.1	0.4	0.0
101.0	0.007	7.1	0.5	0.0	7.1	0.5	0.0	7.1	0.5	0.0
100.5	0.007	7.1	0.5	0.0	7.1	0.5	0.0	7.1	0.5	0.0
100.0	0.047	6.5	1.0	0.1	6.5	1.0	0.1	6.5	1.0	0.1
99.5	0.070	6.5	1.0	0.2	6.5	1.0	0.2	6.5	1.0	0.2
99.0	0.094	6.6	0.9	0.2	6.6	0.9	0.2	6.6	0.9	0.2
98.5	0.117	6.6	0.9	0.2	6.6	0.9	0.2	6.6	0.9	0.2
98.0	0.141	6.6	0.9	0.2	6.6	0.9	0.2	6.6	0.9	0.2
97.5	0.164	6.6	0.8	0.2	6.6	0.8	0.2	6.6	0.8	0.2
97.0	0.187	6.6	0.7	0.2	6.6	0.7	0.2	6.6	0.7	0.2
96.5	0.221	6.6	0.6	0.2	6.6	0.6	0.2	6.6	0.6	0.2
96.0	0.343	5.1	3.6	4.9	5.1	3.6	4.9	5.8	3.6	1.1
95.5	0.343	4.6	3.3	4.6	4.6	3.3	4.6	5.6	3.3	1.1
95.0	0.343	4.5	3.1	4.5	4.5	3.1	4.5	5.6	3.1	1.1
94.5	0.343	4.5	2.8	4.4	4.5	2.8	4.4	5.7	2.8	1.1
94.0	0.343	4.3	2.8	4.2	4.3	2.8	4.2	5.6	2.8	1.1
93.5	0.343	4.4	2.7	4.1	4.4	2.7	4.1	5.7	2.7	1.1
93.0	0.343	4.5	2.5	3.9	4.5	2.5	3.9	5.8	2.5	1.1
92.5	0.343	4.6	2.4	3.8	4.6	2.4	3.8	5.8	2.4	1.1
92.0	0.343	4.6	2.2	3.7	4.6	2.2	3.7	5.9	2.2	1.0
91.5	0.343	4.7	2.1	3.5	4.7	2.1	3.5	6.0	2.1	1.0
91.0	0.343	4.8	2.0	3.4	4.8	2.0	3.4	6.0	2.0	1.0
90.5	0.343	4.9	1.9	3.3	4.9	1.9	3.3	6.1	1.9	1.0
90.0	0.343	4.6	1.6	3.0	4.6	1.6	3.0	6.0	1.6	0.9
89.5	0.343	4.6	1.4	2.7	4.6	1.4	2.7	6.0	1.4	0.8
89.0	0.361	4.7	1.3	2.3	4.7	1.3	2.3	6.0	1.3	0.7
88.5	0.374	4.9	1.2	2.0	4.9	1.2	2.0	6.1	1.2	0.6
88.0	0.388	5.0	1.1	1.8	5.0	1.1	1.8	6.2	1.1	0.6
87.5	0.388	5.2	1.0	1.6	5.2	1.0	1.6	6.3	1.0	0.5
87.0	0.388	5.4	0.9	1.4	5.4	0.9	1.4	6.4	0.9	0.5
86.5	0.388	5.5	0.8	1.3	5.5	0.8	1.3	6.4	0.8	0.4
86.0	0.388	5.7	0.8	1.2	5.7	0.8	1.2	6.5	0.8	0.4
85.5	0.388	5.8	0.7	1.1	5.8	0.7	1.1	6.6	0.7	0.4
85.0	0.388	6.0	0.7	1.0	6.0	0.7	1.0	6.7	0.7	0.3
84.5	0.388	6.1	0.7	0.9	6.1	0.7	0.9	6.7	0.7	0.3
84.0	0.388	6.2	0.6	0.8	6.2	0.6	0.8	6.8	0.6	0.3
83.5	0.431	5.8	1.3	1.4	5.7	2.0	0.9	6.1	2.0	0.6
83.0	0.431	5.7	1.2	1.3	5.6	1.8	0.9	6.0	1.8	0.5
82.5	0.431	5.7	1.1	1.2	5.7	1.7	0.8	6.0	1.7	0.5
82.0	0.431	5.8	1.0	1.1	5.8	1.6	0.8	6.1	1.6	0.5
81.5	0.431	5.9	0.9	1.0	5.8	1.4	0.7	6.1	1.4	0.5
81.0	0.431	6.0	0.9	0.9	5.9	1.3	0.7	6.2	1.3	0.4
80.5	0.431	6.1	0.8	0.8	6.0	1.2	0.6	6.3	1.2	0.4
80.0	0.431	6.2	0.8	0.7	6.1	1.1	0.6	6.3	1.1	0.4
79.5	0.431	6.3	0.7	0.7	6.2	1.1	0.5	6.5	1.0	0.3
79.0	0.431	6.4	0.6	0.5	6.3	1.0	0.5	6.5	0.9	0.3
78.5	0.431	6.5	0.6	0.5	6.4	0.9	0.5	6.6	0.9	0.3
78.0	0.431	6.6	0.6	0.4	6.5	0.9	0.4	6.7	0.8	0.3
77.5	0.431	6.7	0.6	0.4	6.5	0.8	0.4	6.7	0.8	0.3
77.0	0.431	6.7	0.5	0.4	6.6	0.8	0.4	6.8	0.7	0.2
76.5	0.431	6.8	0.5	0.3	6.7	0.7	0.3	6.8	0.7	0.2
76.0	0.431	6.8	0.5	0.3	6.7	0.7	0.3	6.9	0.7	0.2
75.5	0.431	6.9	0.5	0.3	6.8	0.7	0.3	6.9	0.6	0.2
75.0	0.431	6.9	0.5	0.2	6.8	0.6	0.2	6.9	0.6	0.2
74.5	0.431	7.0	0.5	0.2	6.9	0.6	0.2	7.0	0.6	0.1
74.0	0.431	7.0	0.5	0.2	6.9	0.6	0.2	7.0	0.6	0.1
73.5	0.431	7.0	0.5	0.2	6.9	0.6	0.2	7.0	0.6	0.1
73.0	0.431	7.1	0.5	0.1	7.0	0.6	0.2	7.1	0.5	0.1
72.5	0.431	7.1	0.4	0.1	7.0	0.5	0.1	7.1	0.5	0.1
72.0	0.431	7.1	0.4	0.1	7.0	0.5	0.1	7.1	0.5	0.1
71.5	0.431	7.1	0.4	0.1	7.1	0.5	0.1	7.1	0.5	0.1
71.0	0.431	7.1	0.4	0.1	7.1	0.5	0.1	7.1	0.5	0.1
70.5	0.431	7.2	0.4	0.1	7.1	0.5	0.1	7.2	0.5	0.1
70.0	0.431	7.2	0.4	0.1	7.1	0.5	0.1	7.2	0.5	0.0
69.5	0.431	7.2	0.4	0.0	7.2	0.5	0.1	7.2	0.5	0.0
69.0	0.431	7.2	0.4	0.0	7.2	0.5	0.1	7.2	0.4	0.0
68.5	0.431	7.2	0.4	0.0	7.2	0.4	0.0	7.2	0.4	0.0
68.0	0.431	7.2	0.4	0.0	7.2	0.4	0.0	7.2	0.4	0.0
67.5	0.431	7.2	0.4	0.0	7.2	0.4	0.0	7.2	0.4	0.0
67.0	0.431	7.2	0.4	0.0	7.2	0.4	0.0	7.3	0.4	0.0
66.5	0.431	7.3	0.4	0.0	7.2	0.4	0.0	7.3	0.4	0.0
66.0	0.431	7.3	0.4	0.0	7.2	0.4	0.0	7.3	0.4	0.0

^{a/} Scenario B1 - Georgetown and Dove Springs Development Company Only
 B1a1 - G.T. @ 2.5 MGD w/ 10/15/2; D.S. @ 1.0 MGD w/ 10/15/4
 B1a2 - G.T. @ 2.5 MGD w/ 10/15/2; D.S. @ 2.4 MGD w/ 10/3/4
 B1a3 - G.T. @ 2.5 MGD w/ 10/3/4; D.S. @ 2.4 MGD w/ 10/3/4

Figure V.11
 San Gabriel River - Segment 1248
 Dissolved Oxygen Concentrations Assuming
 City of Georgetown and Dove Springs Development WWTPs Only
 — Scenario B1 —

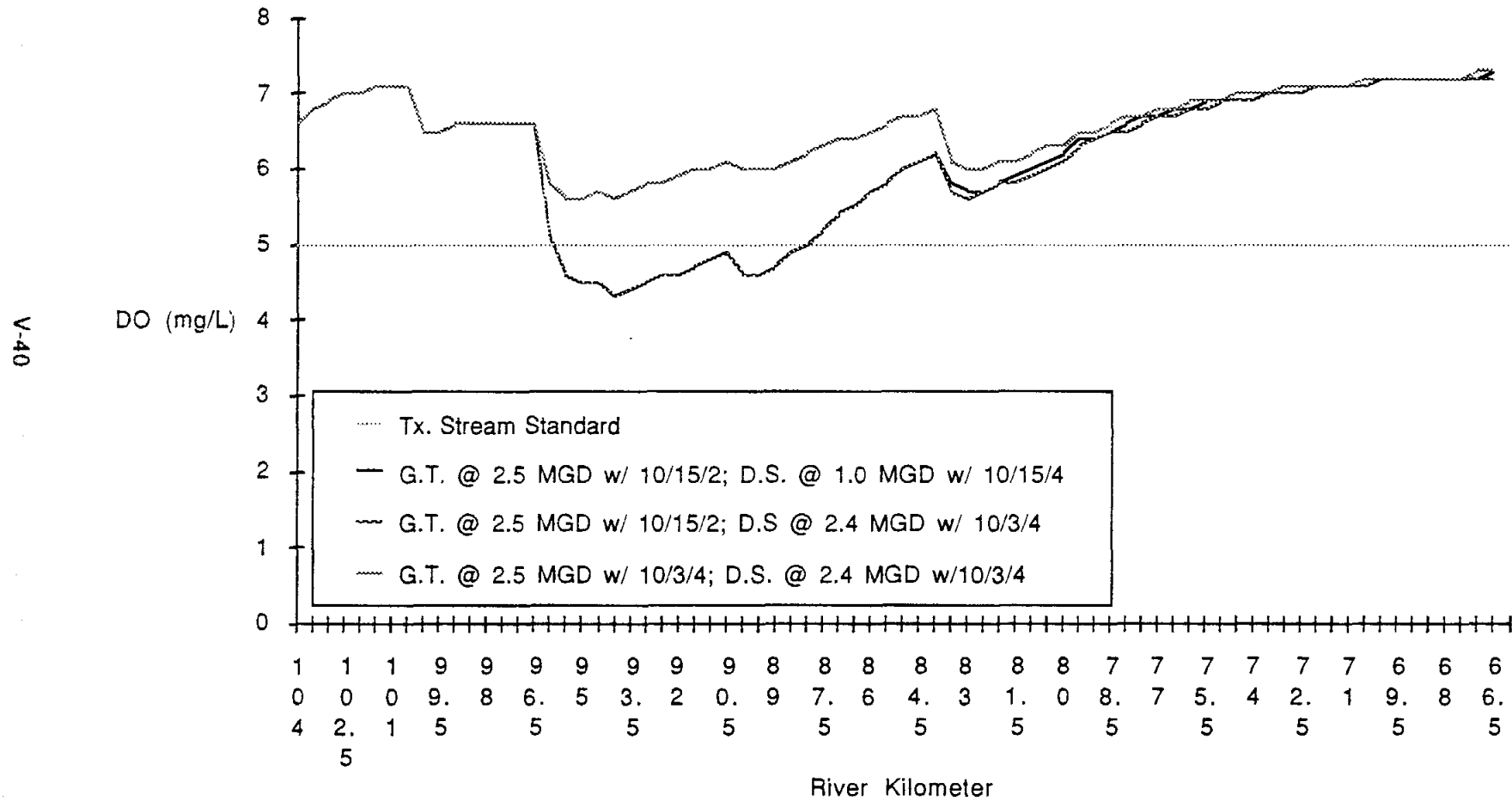

Table V.8
Simulation Scenario B2 - DO, BOD, and NH3 Concentrations a/

River Km	Flow, cms	Simulation Scenario B2a1			Simulation Scenario B2a2		
		DO, mg/L	BOD, mg/L	NH3, mg/L	DO, mg/L	BOD, mg/L	NH3, mg/L
104.0	0.007	6.6	0.6	0.2	6.6	0.6	0.2
103.5	0.007	6.8	0.4	0.2	6.8	0.4	0.2
103.0	0.007	6.9	0.3	0.2	6.9	0.3	0.2
102.5	0.007	7.0	0.4	0.1	7.0	0.4	0.1
102.0	0.007	7.0	0.4	0.1	7.0	0.4	0.1
101.5	0.007	7.1	0.4	0.0	7.1	0.4	0.0
101.0	0.007	7.1	0.5	0.0	7.1	0.5	0.0
100.5	0.007	7.1	0.5	0.0	7.1	0.5	0.0
100.0	0.047	6.5	1.0	0.1	6.5	1.0	0.1
99.5	0.070	6.5	1.0	0.2	6.5	1.0	0.2
99.0	0.094	6.6	0.9	0.2	6.6	0.9	0.2
98.5	0.117	6.6	0.9	0.2	6.6	0.9	0.2
98.0	0.141	6.6	0.9	0.2	6.6	0.9	0.2
97.5	0.164	6.6	0.8	0.2	6.6	0.8	0.2
97.0	0.197	6.6	0.7	0.2	6.6	0.7	0.2
96.5	0.221	6.6	0.6	0.2	6.6	0.6	0.2
96.0	0.408	5.5	4.6	1.4	5.5	4.6	1.4
95.5	0.408	5.2	4.3	1.4	5.2	4.3	1.4
95.0	0.408	5.2	4.0	1.4	5.2	4.0	1.4
94.5	0.408	5.2	3.7	1.4	5.2	3.7	1.4
94.0	0.408	5.2	3.7	1.4	5.2	3.7	1.4
93.5	0.408	5.2	3.5	1.4	5.2	3.5	1.4
93.0	0.408	5.3	3.3	1.4	5.3	3.3	1.4
92.5	0.408	5.4	3.1	1.3	5.4	3.1	1.3
92.0	0.408	5.4	3.0	1.3	5.4	3.0	1.3
91.5	0.408	5.5	2.8	1.3	5.5	2.8	1.3
91.0	0.408	5.6	2.7	1.3	5.6	2.7	1.3
90.5	0.408	5.6	2.5	1.2	5.6	2.5	1.2
90.0	0.408	5.5	2.2	1.2	5.5	2.2	1.2
89.5	0.408	5.5	2.0	1.1	5.5	2.0	1.1
89.0	0.427	5.5	1.7	1.0	5.5	1.7	1.0
88.5	0.440	5.6	1.6	0.9	5.6	1.6	0.9
88.0	0.453	5.7	1.4	0.8	5.7	1.4	0.8
87.5	0.453	5.8	1.3	0.7	5.8	1.3	0.7
87.0	0.453	6.0	1.2	0.7	6.0	1.2	0.7
86.5	0.453	6.1	1.1	0.6	6.1	1.1	0.6
86.0	0.453	6.2	1.0	0.6	6.2	1.0	0.6
85.5	0.453	6.3	1.0	0.5	6.3	1.0	0.5
85.0	0.453	6.3	0.9	0.5	6.3	0.9	0.5
84.5	0.453	6.4	0.8	0.4	6.4	0.8	0.4
84.0	0.453	6.5	0.8	0.4	6.5	0.8	0.4
83.5	0.506	6.2	1.4	0.5	6.0	2.0	0.6
83.0	0.506	6.2	1.3	0.5	5.9	1.8	0.6
82.5	0.506	6.3	1.2	0.5	6.0	1.7	0.6
82.0	0.506	6.3	1.1	0.4	6.0	1.6	0.6
81.5	0.506	6.4	1.1	0.4	6.1	1.5	0.5
81.0	0.506	6.5	1.0	0.4	6.1	1.4	0.5
80.5	0.506	6.5	0.9	0.3	6.2	1.3	0.5
80.0	0.506	6.6	0.9	0.3	6.3	1.2	0.4
79.5	0.506	6.6	0.8	0.3	6.3	1.1	0.4
79.0	0.506	6.7	0.8	0.3	6.4	1.0	0.4
78.5	0.506	6.7	0.7	0.3	6.5	1.0	0.4
78.0	0.506	6.8	0.7	0.2	6.5	0.9	0.3
77.5	0.508	6.8	0.7	0.2	6.6	0.9	0.3
77.0	0.506	6.9	0.6	0.2	6.7	0.8	0.3
76.5	0.506	6.9	0.6	0.2	6.7	0.8	0.3
76.0	0.506	7.0	0.6	0.2	6.8	0.7	0.2
75.5	0.506	7.0	0.6	0.1	6.8	0.7	0.2
75.0	0.506	7.0	0.6	0.1	6.9	0.7	0.2
74.5	0.506	7.0	0.5	0.1	6.9	0.7	0.2
74.0	0.506	7.1	0.5	0.1	6.9	0.6	0.2
73.5	0.508	7.1	0.5	0.1	7.0	0.6	0.2
73.0	0.506	7.1	0.5	0.1	7.0	0.6	0.1
72.5	0.506	7.1	0.5	0.1	7.0	0.6	0.1
72.0	0.506	7.2	0.5	0.1	7.1	0.5	0.1
71.5	0.506	7.2	0.5	0.1	7.1	0.5	0.1
71.0	0.506	7.2	0.5	0.0	7.1	0.5	0.1
70.5	0.506	7.2	0.5	0.0	7.1	0.5	0.1
70.0	0.506	7.2	0.4	0.0	7.1	0.5	0.1
69.5	0.506	7.2	0.4	0.0	7.2	0.5	0.1
69.0	0.508	7.2	0.4	0.0	7.2	0.5	0.1
68.5	0.506	7.2	0.4	0.0	7.2	0.5	0.0
68.0	0.506	7.3	0.4	0.0	7.2	0.5	0.0
67.5	0.506	7.3	0.4	0.0	7.2	0.5	0.0
67.0	0.506	7.3	0.4	0.0	7.2	0.4	0.0
66.5	0.506	7.3	0.4	0.0	7.2	0.4	0.0
66.0	0.506	7.3	0.4	0.0	7.3	0.4	0.0

a/ Scenario B2 - Georgetown and Dove Springs Development Company Only
 B2a1 - G.T. @ 4.0 MGD w/ 10/3/4; D.S. @ 1.2 MGD w/ 10/3/4
 B2a2 - G.T. @ 4.0 MGD w/ 10/3/4; D.S. @ 2.4 MGD w/ 10/3/4

Figure V.12
 San Gabriel River - Segment 1248
 Dissolved Oxygen Concentrations Assuming
 City of Georgetown and Dove Springs Development WWTPs Only
 — Scenario B2 —

V-42

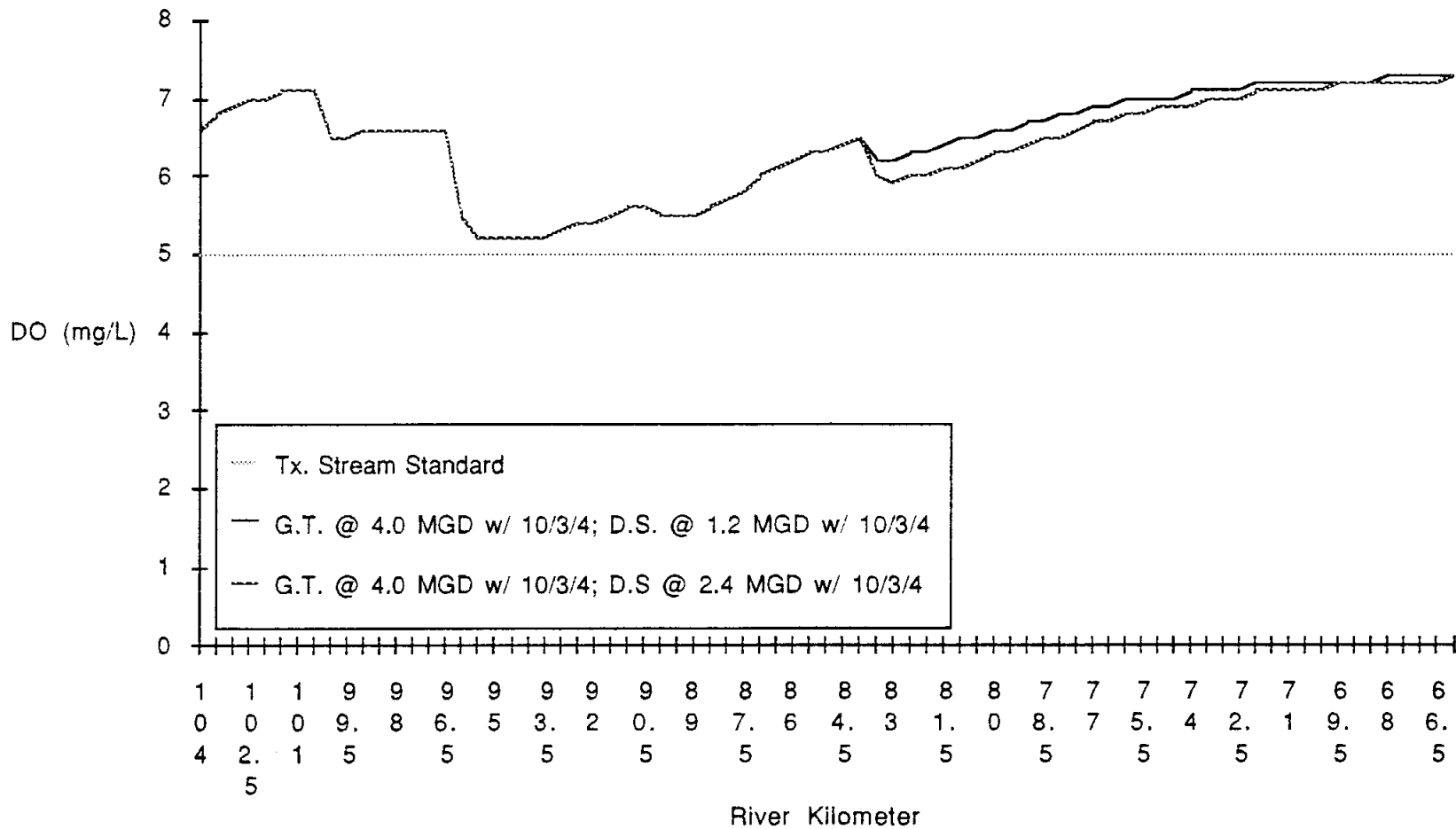

Table V.9
Simulation Scenario C1 - DO, BOD, and NH3 Concentrations a/

River Km	Flow, cms	Simulation Scenario C1a1			Simulation Scenario C1a2			Simulation Scenario C1a3		
		DO, mg/L	BOD, mg/L	NH3, mg/L	DO, mg/L	BOD, mg/L	NH3, mg/L	DO, mg/L	BOD, mg/L	NH3, mg/L
104.0	0.007	6.6	0.6	0.2	6.6	0.6	0.2	6.6	0.6	0.2
103.5	0.007	6.8	0.4	0.2	6.8	0.4	0.2	6.8	0.4	0.2
103.0	0.007	6.9	0.3	0.2	6.9	0.3	0.2	6.9	0.3	0.2
102.5	0.007	7.0	0.4	0.1	7.0	0.4	0.1	7.0	0.4	0.1
102.0	0.007	7.0	0.4	0.1	7.0	0.4	0.1	7.0	0.4	0.1
101.5	0.007	7.1	0.4	0.0	7.1	0.4	0.0	7.1	0.4	0.0
101.0	0.007	7.1	0.5	0.0	7.1	0.5	0.0	7.1	0.5	0.0
100.5	0.007	7.1	0.5	0.0	7.1	0.5	0.0	7.1	0.5	0.0
100.0	0.047	6.5	1.0	0.1	6.5	1.0	0.1	6.5	1.0	0.1
99.5	0.070	6.5	1.0	0.2	6.5	1.0	0.2	6.5	1.0	0.2
99.0	0.094	6.6	0.9	0.2	6.6	0.9	0.2	6.6	0.9	0.2
98.5	0.117	6.6	0.9	0.2	6.6	0.9	0.2	6.6	0.9	0.2
98.0	0.141	6.6	0.9	0.2	6.6	0.9	0.2	6.6	0.9	0.2
97.5	0.164	6.6	0.8	0.2	6.6	0.8	0.2	6.6	0.8	0.2
97.0	0.197	6.6	0.7	0.2	6.6	0.7	0.2	6.6	0.7	0.2
96.5	0.221	6.6	0.6	0.2	6.6	0.6	0.2	6.6	0.6	0.2
96.0	0.343	5.1	3.6	4.9	5.8	3.6	1.1	5.8	3.6	1.1
95.5	0.343	4.6	3.3	4.6	5.6	3.3	1.1	5.6	3.3	1.1
95.0	0.343	4.5	3.1	4.5	5.6	3.1	1.1	5.6	3.1	1.1
94.5	0.343	4.5	2.8	4.4	5.7	2.8	1.1	5.7	2.8	1.1
94.0	0.343	4.3	2.8	4.2	5.6	2.8	1.1	5.6	2.8	1.1
93.5	0.343	4.4	2.7	4.1	5.7	2.7	1.1	5.7	2.7	1.1
93.0	0.343	4.5	2.5	3.9	5.8	2.5	1.1	5.8	2.5	1.1
92.5	0.343	4.6	2.4	3.8	5.8	2.4	1.1	5.8	2.4	1.1
92.0	0.343	4.6	2.2	3.7	5.9	2.2	1.0	5.9	2.2	1.0
91.5	0.343	4.7	2.1	3.5	6.0	2.1	1.0	6.0	2.1	1.0
91.0	0.343	4.8	2.0	3.4	6.0	2.0	1.0	6.0	2.0	1.0
90.5	0.343	4.9	1.9	3.3	6.1	1.9	1.0	6.1	1.9	1.0
90.0	0.343	4.6	1.6	3.0	6.0	1.6	0.9	6.0	1.6	0.9
89.5	0.343	4.6	1.4	2.7	6.0	1.4	0.8	6.0	1.4	0.8
89.0	0.361	4.7	1.3	2.3	6.0	1.3	0.7	6.0	1.3	0.7
88.5	0.374	4.9	1.2	2.0	6.1	1.2	0.6	6.1	1.2	0.6
88.0	0.388	5.0	1.1	1.8	6.2	1.1	0.6	6.2	1.1	0.6
87.5	0.388	5.2	1.0	1.6	6.3	1.0	0.5	6.3	1.0	0.5
87.0	0.388	5.4	0.9	1.4	6.4	0.9	0.5	6.4	0.9	0.5
86.5	0.388	5.5	0.8	1.3	6.4	0.8	0.4	6.4	0.8	0.4
86.0	0.388	5.7	0.8	1.2	6.5	0.8	0.4	6.5	0.8	0.4
85.5	0.388	5.8	0.7	1.1	6.6	0.7	0.4	6.6	0.7	0.4
85.0	0.388	6.0	0.7	1.0	6.6	0.7	0.3	6.7	0.7	0.3
84.5	0.585	4.9	3.6	1.6	5.3	3.6	1.2	5.7	2.9	1.0
84.0	0.585	4.7	3.3	1.5	5.1	3.3	1.1	5.5	2.6	0.9
83.5	0.629	4.4	3.4	1.9	4.9	3.4	1.1	5.1	3.3	1.0
83.0	0.629	4.3	3.1	1.8	4.8	3.1	1.1	5.0	3.0	1.0
82.5	0.629	4.3	2.9	1.7	4.9	2.9	1.0	5.0	2.8	0.9
82.0	0.629	4.4	2.6	1.6	4.9	2.6	1.0	5.1	2.6	0.9
81.5	0.629	4.5	2.4	1.5	5.0	2.4	0.9	5.2	2.4	0.9
81.0	0.629	4.6	2.3	1.4	5.1	2.3	0.9	5.3	2.2	0.8
80.5	0.629	4.8	2.1	1.3	5.2	2.1	0.9	5.4	2.0	0.8
80.0	0.629	4.9	1.9	1.2	5.4	1.9	0.8	5.5	1.9	0.7
79.5	0.629	5.0	1.8	1.2	5.5	1.8	0.8	5.6	1.7	0.7
79.0	0.629	5.2	1.7	1.1	5.6	1.7	0.7	5.7	1.6	0.7
78.5	0.629	5.3	1.6	1.0	5.7	1.6	0.7	5.8	1.5	0.6
78.0	0.629	5.5	1.5	0.9	5.8	1.5	0.6	5.9	1.4	0.6
77.5	0.629	5.6	1.4	0.9	5.9	1.4	0.6	6.0	1.3	0.5
77.0	0.629	5.7	1.3	0.8	6.0	1.3	0.6	6.1	1.2	0.5
76.5	0.629	5.8	1.2	0.8	6.1	1.2	0.5	6.2	1.2	0.5
76.0	0.629	5.9	1.1	0.7	6.2	1.1	0.5	6.3	1.1	0.4
75.5	0.629	6.0	1.1	0.6	6.3	1.1	0.5	6.3	1.0	0.4
75.0	0.629	6.1	1.0	0.6	6.4	1.0	0.4	6.4	1.0	0.4
74.5	0.629	6.2	1.0	0.6	6.4	1.0	0.4	6.5	0.9	0.4
74.0	0.629	6.3	0.9	0.5	6.5	0.9	0.4	6.6	0.9	0.3
73.5	0.629	6.4	0.9	0.5	6.6	0.9	0.3	6.6	0.8	0.3
73.0	0.629	6.5	0.8	0.4	6.6	0.8	0.3	6.7	0.8	0.3
72.5	0.629	6.5	0.8	0.4	6.7	0.8	0.3	6.7	0.8	0.3
72.0	0.629	6.6	0.7	0.4	6.7	0.7	0.3	6.8	0.7	0.2
71.5	0.629	6.7	0.7	0.3	6.8	0.7	0.2	6.8	0.7	0.2
71.0	0.629	6.7	0.7	0.3	6.8	0.7	0.2	6.9	0.7	0.2
70.5	0.629	6.8	0.7	0.3	6.9	0.7	0.2	6.9	0.6	0.2
70.0	0.629	6.8	0.6	0.3	6.9	0.6	0.2	6.9	0.6	0.2
69.5	0.629	6.9	0.6	0.2	6.9	0.6	0.2	7.0	0.6	0.2
69.0	0.629	6.9	0.6	0.2	7.0	0.6	0.2	7.0	0.6	0.1
68.5	0.629	6.9	0.6	0.2	7.0	0.6	0.1	7.0	0.6	0.1
68.0	0.629	7.0	0.6	0.2	7.0	0.6	0.1	7.1	0.6	0.1
67.5	0.629	7.0	0.5	0.2	7.1	0.5	0.1	7.1	0.5	0.1
67.0	0.629	7.0	0.5	0.1	7.1	0.5	0.1	7.1	0.5	0.1
66.5	0.629	7.1	0.5	0.1	7.1	0.5	0.1	7.1	0.5	0.1
66.0	0.629	7.1	0.5	0.1	7.1	0.5	0.1	7.1	0.5	0.1

A/ Scenario C1 - City of Georgetown, Dove Springs Development Company, and Manlin's Crossing Facility
 C1a1 - G.T. @ 2.5 MGD w/ 10/15/2; D.S. @ 1.0 MGD w/ 10/3/4; M.X. @ 4.5 MGD w/ 10/3/4
 C1a2 - G.T. @ 2.5 MGD w/ 10/3/4; D.S. @ 1.0 MGD w/ 10/3/4; M.X. @ 4.5 MGD w/ 10/3/4
 C1a3 - G.T. @ 2.5 MGD w/ 10/3/4; D.S. @ 2.4 MGD w/ 10/3/4; M.X. @ 3.0 MGD w/ 10/3/4

Scenario C2 (Table V.10 and Figure V.14) does not indicate any violations of the State's water quality criteria.

Scenario D1 (Table V.11 and Figure V.15) again demonstrates that the key to minimizing the adverse impacts of all future development on the water quality of the San Gabriel River is the upgrading of the Georgetown facility to a treatment level of 10/3/4.

Scenario D2 (Table V.12 and Figure V.16) demonstrates that a 3 MGD facility at a treatment level of 10/3/4 built near the confluence of Berry Creek and the San Gabriel River would result in a violation of the State's water quality criteria even with the Dove Springs Development Corporation plant limited to 1 MGD at a treatment level of 10/3/4. A more appropriate development scenario for this combination of plants, from a water quality standpoint, would be to enlarge the Dove Springs Development Corporation facility to 2.4 MGD and limit the Berry Creek plant to 1.6 MGD.

Scenario E (Table V.13 and Figure V.17) examined the probability of developing one large regional wastewater facility to accommodate 7 MGD constructed near the confluence of Berry Creek and the San Gabriel River. Simulations indicate that a treatment level of 5/2/2 would be necessary to maintain dissolved oxygen levels above the State criteria of 5.0 mg/L.

Scenario F (Table V.14 and Figure V.18) also examined the construction of a single, 8 MGD facility near Mankin's Creek Branch confluence with the San Gabriel River. Simulations, again, indicate that a treatment level of at least 5/2/5 would be necessary to maintain a 5 mg/L DO level downstream of the outfall.

Scenario G (Table V.15 and Figure V.19) assumes that there are three treatment plants: the existing City of Georgetown plant at 2.5 MGD, a 2 MGD facility built near the confluence of Pecan Branch, Berry Creek and the San Gabriel River and a 3 MGD facility near the confluence of Mankin's Branch and the San Gabriel River. Simulations demonstrate that operating all of the plants at a treatment level of 10/3/4 would maintain the 5 mg/l DO standard for Segment 1248 downstream of all outfalls.

Scenario H (Table V.16 and Figure V.20) is a two plant scenario. The Georgetown treatment plant could operate at 2.5 MGD at a treatment level of 10/3/4 and maintain Segment 1248 minimum DO concentration levels at 5 mg/L. However, a Mankin's Crossing facility at 5.5 MGD would require a treatment level of 10/2/6 to maintain DO levels greater than 5 mg/L downstream of its outfall.

Table V.10
Simulation Scenario C2 - DO, BOD, and NH3 Concentrations a/

River Km	Flow, cms	Simulation Scenario C2a1			Simulation Scenario C2a2		
		DO, mg/L	BOD, mg/L	NH3, mg/L	DO, mg/L	BOD, mg/L	NH3, mg/L
104.0	0.007	6.6	0.6	0.2	6.6	0.6	0.2
103.5	0.007	6.8	0.4	0.2	6.8	0.4	0.2
103.0	0.007	6.9	0.3	0.2	6.9	0.3	0.2
102.5	0.007	7.0	0.4	0.1	7.0	0.4	0.1
102.0	0.007	7.0	0.4	0.1	7.0	0.4	0.1
101.5	0.007	7.1	0.4	0.0	7.1	0.4	0.0
101.0	0.007	7.1	0.5	0.0	7.1	0.5	0.0
100.5	0.007	7.1	0.5	0.0	7.1	0.5	0.0
100.0	0.047	6.5	1.0	0.1	6.5	1.0	0.1
99.5	0.070	6.5	1.0	0.2	6.5	1.0	0.2
99.0	0.094	6.6	0.9	0.2	6.6	0.9	0.2
98.5	0.117	6.6	0.9	0.2	6.6	0.9	0.2
98.0	0.141	6.6	0.9	0.2	6.6	0.9	0.2
97.5	0.164	6.6	0.8	0.2	6.6	0.8	0.2
97.0	0.197	6.6	0.7	0.2	6.6	0.7	0.2
96.5	0.221	6.6	0.6	0.2	6.6	0.6	0.2
96.0	0.408	5.5	4.6	1.4	5.5	4.6	1.4
95.5	0.408	5.2	4.3	1.4	5.2	4.3	1.4
95.0	0.408	5.2	4.0	1.4	5.2	4.0	1.4
94.5	0.408	5.2	3.7	1.4	5.2	3.7	1.4
94.0	0.408	5.2	3.7	1.4	5.2	3.7	1.4
93.5	0.408	5.2	3.5	1.4	5.2	3.5	1.4
93.0	0.408	5.3	3.3	1.4	5.3	3.3	1.4
92.5	0.408	5.4	3.1	1.3	5.4	3.1	1.3
92.0	0.408	5.4	3.0	1.3	5.4	3.0	1.3
91.5	0.408	5.5	2.8	1.3	5.5	2.8	1.3
91.0	0.408	5.6	2.7	1.3	5.6	2.7	1.3
90.5	0.408	5.6	2.5	1.2	5.6	2.5	1.2
90.0	0.408	5.5	2.2	1.2	5.5	2.2	1.2
89.5	0.408	5.5	2.0	1.1	5.5	2.0	1.1
89.0	0.426	5.5	1.7	1.0	5.5	1.7	1.0
88.5	0.440	5.6	1.6	0.9	5.6	1.6	0.9
88.0	0.453	5.7	1.4	0.8	5.7	1.4	0.8
87.5	0.453	5.8	1.3	0.7	5.8	1.3	0.7
87.0	0.453	6.0	1.2	0.7	6.0	1.2	0.7
86.5	0.453	6.1	1.1	0.6	6.1	1.1	0.6
86.0	0.453	6.2	1.0	0.6	6.2	1.0	0.6
85.5	0.453	6.3	1.0	0.5	6.3	1.0	0.5
85.0	0.453	6.3	0.9	0.5	6.3	0.9	0.5
84.5	0.585	5.6	2.8	1.0	5.9	2.0	0.8
84.0	0.585	5.4	2.6	1.0	5.9	1.8	0.7
83.5	0.628	5.3	2.7	1.0	5.4	2.7	0.9
83.0	0.628	5.2	2.5	0.9	5.4	2.5	0.8
82.5	0.628	5.3	2.3	0.9	5.4	2.3	0.8
82.0	0.628	5.3	2.2	0.8	5.5	2.1	0.8
81.5	0.628	5.4	2.0	0.8	5.6	2.0	0.7
81.0	0.628	5.5	1.9	0.7	5.6	1.8	0.7
80.5	0.628	5.6	1.7	0.7	5.7	1.7	0.7
80.0	0.628	5.7	1.6	0.7	5.8	1.6	0.6
79.5	0.628	5.8	1.5	0.6	5.9	1.5	0.6
79.0	0.628	5.9	1.4	0.6	6.0	1.4	0.5
78.5	0.628	6.0	1.3	0.6	6.1	1.3	0.5
78.0	0.628	6.1	1.2	0.5	6.2	1.2	0.5
77.5	0.628	6.2	1.2	0.5	6.3	1.1	0.5
77.0	0.628	6.3	1.1	0.5	6.3	1.1	0.4
76.5	0.628	6.4	1.0	0.4	6.4	1.0	0.4
76.0	0.628	6.4	1.0	0.4	6.5	1.0	0.4
75.5	0.628	6.5	0.9	0.4	6.5	0.9	0.3
75.0	0.628	6.6	0.9	0.3	6.6	0.9	0.3
74.5	0.628	6.6	0.8	0.3	6.7	0.8	0.3
74.0	0.628	6.7	0.8	0.3	6.7	0.8	0.3
73.5	0.628	6.7	0.8	0.3	6.8	0.7	0.3
73.0	0.628	6.8	0.7	0.2	6.8	0.7	0.2
72.5	0.628	6.8	0.7	0.2	6.8	0.7	0.2
72.0	0.628	6.9	0.7	0.2	6.9	0.7	0.2
71.5	0.628	6.9	0.6	0.2	6.9	0.6	0.2
71.0	0.628	6.9	0.6	0.2	7.0	0.6	0.2
70.5	0.628	7.0	0.6	0.2	7.0	0.6	0.1
70.0	0.628	7.0	0.6	0.1	7.0	0.6	0.1
69.5	0.628	7.0	0.6	0.1	7.0	0.6	0.1
69.0	0.628	7.1	0.5	0.1	7.1	0.5	0.1
68.5	0.628	7.1	0.5	0.1	7.1	0.5	0.1
68.0	0.628	7.1	0.5	0.1	7.1	0.5	0.1
67.5	0.628	7.1	0.5	0.1	7.1	0.5	0.1
67.0	0.628	7.2	0.5	0.1	7.2	0.5	0.1
66.5	0.628	7.2	0.5	0.1	7.2	0.5	0.1
66.0	0.628	7.2	0.5	0.1	7.2	0.5	0.1

a/ Scenario C2 - City of Georgetown, Dove Springs Development Company, and Mankin's Crossing Facility
C2a1 - G.T. @ 4.0 MGD w/ 10/3/4; D.S. 1.0 MGD w/ 10/3/4; M.X. @ 3.0 MGD w/ 10/3/4
C2a2 - G.T. @ 4.0 MGD w/ 10/3/4; D.S. 2.4 MGD w/ 10/3/4; M.X. @ 1.6 MGD w/ 10/3/4

Figure V.14
 San Gabriel River - Segment 1248
 Dissolved Oxygen Concentrations Assuming City of Georgetown,
 Dove Springs Development, and Mankin's Crossing WWTPs
 — Scenario C2 —

V-47

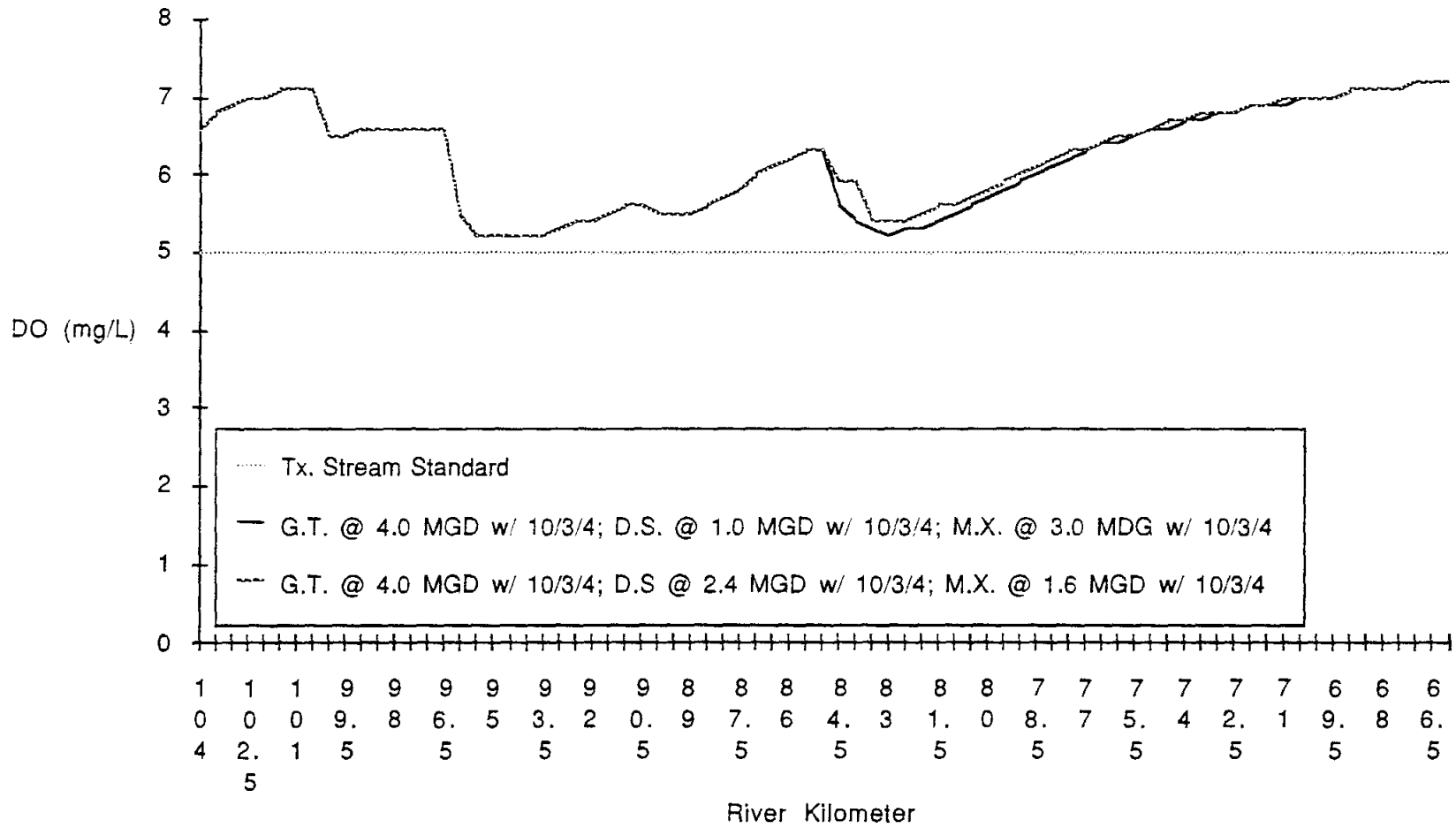

Table V.11
Simulation Scenario D1 - DO, BOD, and NH3 Concentrations a/

River Km	Flow, cms	Simulation Scenario D1a1			Simulation Scenario D1a2		
		DO, mg/L	BOD, mg/L	NH3, mg/L	DO, mg/L	BOD, mg/L	NH3, mg/L
104.0	0.007	6.6	0.6	0.2	6.6	0.6	0.2
103.5	0.007	6.8	0.4	0.2	6.8	0.4	0.2
103.0	0.007	6.9	0.3	0.2	6.9	0.3	0.2
102.5	0.007	7.0	0.4	0.1	7.0	0.4	0.1
102.0	0.007	7.0	0.4	0.1	7.0	0.4	0.1
101.5	0.007	7.1	0.4	0.0	7.1	0.4	0.0
101.0	0.007	7.1	0.5	0.0	7.1	0.5	0.0
100.5	0.007	7.1	0.5	0.0	7.1	0.5	0.0
100.0	0.047	6.5	1.0	0.1	6.5	1.0	0.1
99.5	0.070	6.5	1.0	0.2	6.5	1.0	0.2
99.0	0.094	6.6	0.9	0.2	6.6	0.9	0.2
98.5	0.117	6.6	0.9	0.2	6.6	0.9	0.2
98.0	0.141	6.6	0.9	0.2	6.6	0.9	0.2
97.5	0.164	6.6	0.8	0.2	6.6	0.8	0.2
97.0	0.197	6.6	0.7	0.2	6.6	0.7	0.2
96.5	0.221	6.6	0.6	0.2	6.6	0.6	0.2
96.0	0.343	5.1	3.6	4.9	5.8	3.6	1.1
95.5	0.343	4.6	3.3	4.6	5.6	3.3	1.1
95.0	0.343	4.5	3.1	4.5	5.6	3.1	1.1
94.5	0.343	4.5	2.8	4.4	5.7	2.8	1.1
94.0	0.343	4.3	2.8	4.2	5.6	2.8	1.1
93.5	0.343	4.4	2.7	4.1	5.7	2.7	1.1
93.0	0.343	4.5	2.5	3.9	5.8	2.5	1.1
92.5	0.343	4.6	2.4	3.8	5.8	2.4	1.1
92.0	0.343	4.6	2.2	3.7	5.9	2.2	1.0
91.5	0.343	4.7	2.1	3.5	6.0	2.1	1.0
91.0	0.343	4.8	2.0	3.4	6.0	2.0	1.0
90.5	0.343	4.9	1.9	3.3	6.1	1.9	1.0
90.0	0.343	4.6	1.6	3.0	6.0	1.6	0.9
89.5	0.343	4.6	1.4	2.7	6.0	1.4	0.8
89.0	0.448	4.3	2.8	2.4	5.3	2.8	1.2
88.5	0.462	4.2	2.5	2.2	5.3	2.5	1.1
88.0	0.475	4.3	2.3	2.0	5.3	2.3	1.0
87.5	0.475	4.4	2.1	1.8	5.3	2.1	0.9
87.0	0.475	4.6	1.9	1.7	5.4	1.9	0.9
86.5	0.475	4.7	1.7	1.6	5.5	1.7	0.8
86.0	0.475	4.9	1.6	1.5	5.7	1.6	0.8
85.5	0.475	5.1	1.5	1.3	5.8	1.5	0.7
85.0	0.475	5.2	1.3	1.2	5.9	1.3	0.7
84.5	0.585	4.9	2.8	1.5	5.4	2.8	1.0
84.0	0.585	4.8	2.6	1.4	5.3	2.6	1.0
83.5	0.628	4.8	2.7	1.3	5.1	2.7	1.0
83.0	0.628	4.8	2.5	1.3	5.2	2.5	1.0
82.5	0.628	4.9	2.3	1.2	5.2	2.3	0.9
82.0	0.628	5.0	2.2	1.1	5.3	2.2	0.9
81.5	0.628	5.1	2.0	1.1	5.4	2.0	0.8
81.0	0.628	5.2	1.9	1.0	5.5	1.9	0.8
80.5	0.628	5.3	1.7	0.9	5.6	1.7	0.7
80.0	0.628	5.5	1.6	0.9	5.7	1.6	0.7
79.5	0.628	5.6	1.5	0.8	5.8	1.5	0.6
79.0	0.628	5.7	1.4	0.8	5.9	1.4	0.6
78.5	0.628	5.8	1.3	0.7	6.0	1.3	0.6
78.0	0.628	5.9	1.2	0.7	6.1	1.2	0.5
77.5	0.628	6.0	1.2	0.6	6.2	1.2	0.5
77.0	0.628	6.1	1.1	0.6	6.3	1.1	0.5
76.5	0.628	6.2	1.0	0.5	6.3	1.0	0.4
76.0	0.628	6.3	1.0	0.5	6.4	1.0	0.4
75.5	0.628	6.4	0.9	0.5	6.5	0.9	0.4
75.0	0.628	6.4	0.9	0.4	6.6	0.9	0.3
74.5	0.628	6.5	0.8	0.4	6.6	0.8	0.3
74.0	0.628	6.6	0.8	0.4	6.7	0.8	0.3
73.5	0.628	6.6	0.8	0.3	6.7	0.8	0.3
73.0	0.628	6.7	0.7	0.3	6.8	0.7	0.3
72.5	0.628	6.7	0.7	0.3	6.8	0.7	0.2
72.0	0.628	6.8	0.7	0.3	6.9	0.7	0.2
71.5	0.628	6.8	0.6	0.2	6.9	0.6	0.2
71.0	0.628	6.9	0.6	0.2	6.9	0.6	0.2
70.5	0.628	6.9	0.6	0.2	7.0	0.6	0.2
70.0	0.628	7.0	0.6	0.2	7.0	0.6	0.1
69.5	0.628	7.0	0.6	0.2	7.0	0.6	0.1
69.0	0.628	7.0	0.5	0.1	7.1	0.5	0.1
68.5	0.628	7.0	0.5	0.1	7.1	0.5	0.1
68.0	0.628	7.1	0.5	0.1	7.1	0.5	0.1
67.5	0.628	7.1	0.5	0.1	7.1	0.5	0.1
67.0	0.628	7.1	0.5	0.1	7.2	0.5	0.1
66.5	0.628	7.1	0.5	0.1	7.2	0.5	0.1
66.0	0.628	7.2	0.5	0.1	7.2	0.5	0.1

a/ Scenario D1 - City of Georgetown, Dove Springs Development Company, Mankin's Crossing, and Berry Creek Facilities
D1a1 - G.T. @ 2.5 MGD w/ 10/15/2; D.S. 1.0 MGD w/ 10/3/4; B.C. @ 2.0 MGD w/ 10/3/4; M.X. @ 2.5 MGD w/ 10/3/4
D1a2 - G.T. @ 2.5 MGD w/ 10/3/4; D.S. 1.0 MGD w/ 10/3/4; B.C. @ 2.0 MGD w/ 10/3/4; M.X. @ 2.5 MGD w/ 10/3/4

Table V.12
Simulation Scenario D2 - DO, BOD, and NH3 Concentrations a/

River Km	Flow, cms	Simulation Scenario D2a1			Simulation Scenario D2a2		
		DO, mg/L	BOD, mg/L	NH3, mg/L	DO, mg/L	BOD, mg/L	NH3, mg/L
104.0	0.007	6.6	0.6	0.2	6.6	0.6	0.2
103.5	0.007	6.8	0.4	0.2	6.8	0.4	0.2
103.0	0.007	6.9	0.3	0.2	6.9	0.3	0.2
102.5	0.007	7.0	0.4	0.1	7.0	0.4	0.1
102.0	0.007	7.0	0.4	0.1	7.0	0.4	0.1
101.5	0.007	7.1	0.4	0.0	7.1	0.4	0.0
101.0	0.007	7.1	0.5	0.0	7.1	0.5	0.0
100.5	0.007	7.1	0.5	0.0	7.1	0.5	0.0
100.0	0.047	6.5	1.0	0.1	6.5	1.0	0.1
99.5	0.070	6.5	1.0	0.2	6.5	1.0	0.2
99.0	0.094	6.6	0.9	0.2	6.6	0.9	0.2
98.5	0.117	6.6	0.9	0.2	6.6	0.9	0.2
98.0	0.141	6.6	0.9	0.2	6.6	0.9	0.2
97.5	0.164	6.6	0.8	0.2	6.6	0.8	0.2
97.0	0.197	6.6	0.7	0.2	6.6	0.7	0.2
96.5	0.221	6.6	0.6	0.2	6.6	0.6	0.2
96.0	0.408	5.5	4.6	1.4	5.5	4.6	1.4
95.5	0.408	5.2	4.3	1.4	5.2	4.3	1.4
95.0	0.408	5.2	4.0	1.4	5.2	4.0	1.4
94.5	0.408	5.2	3.7	1.4	5.2	3.7	1.4
94.0	0.408	5.2	3.7	1.4	5.2	3.7	1.4
93.5	0.408	5.2	3.5	1.4	5.2	3.5	1.4
93.0	0.408	5.3	3.3	1.4	5.3	3.3	1.4
92.5	0.408	5.4	3.1	1.3	5.4	3.1	1.3
92.0	0.408	5.4	3.0	1.3	5.4	3.0	1.3
91.5	0.408	5.5	2.8	1.3	5.5	2.8	1.3
91.0	0.408	5.6	2.7	1.3	5.6	2.7	1.3
90.5	0.408	5.7	2.5	1.2	5.6	2.5	1.2
90.0	0.408	5.5	2.2	1.2	5.5	2.2	1.2
89.5	0.408	5.5	2.0	1.1	5.5	2.0	1.1
89.0	0.558	4.8	3.6	1.4	5.1	2.8	1.2
88.5	0.571	4.7	3.2	1.3	5.1	2.5	1.1
88.0	0.585	4.7	2.9	1.2	5.1	2.3	1.1
87.5	0.585	4.8	2.7	1.2	5.2	2.1	1.0
87.0	0.585	4.9	2.5	1.1	5.3	1.9	0.9
86.5	0.585	5.0	2.3	1.1	5.4	1.8	0.9
86.0	0.585	5.1	2.1	1.0	5.5	1.6	0.8
85.5	0.585	5.2	1.9	0.9	5.7	1.5	0.8
85.0	0.585	5.4	1.8	0.9	5.8	1.4	0.7
84.5	0.585	5.5	1.7	0.8	5.9	1.3	0.7
84.0	0.585	5.6	1.5	0.8	6.0	1.2	0.6
83.5	0.628	5.6	1.9	0.8	5.6	2.2	0.8
83.0	0.628	5.6	1.7	0.8	5.6	2.0	0.7
82.5	0.628	5.7	1.6	0.7	5.7	1.9	0.7
82.0	0.628	5.8	1.5	0.7	5.7	1.7	0.7
81.5	0.628	5.9	1.4	0.6	5.8	1.6	0.6
81.0	0.628	6.0	1.3	0.6	5.9	1.5	0.6
80.5	0.628	6.1	1.2	0.5	6.0	1.4	0.6
80.0	0.628	6.2	1.2	0.5	6.1	1.3	0.5
79.5	0.628	6.2	1.1	0.5	6.1	1.2	0.5
79.0	0.628	6.3	1.0	0.4	6.2	1.2	0.5
78.5	0.628	6.4	1.0	0.4	6.3	1.1	0.4
78.0	0.628	6.5	0.9	0.4	6.4	1.0	0.4
77.5	0.628	6.5	0.9	0.4	6.4	1.0	0.4
77.0	0.628	6.6	0.8	0.3	6.5	0.9	0.4
76.5	0.628	6.7	0.8	0.3	6.6	0.9	0.3
76.0	0.628	6.7	0.8	0.3	6.6	0.8	0.3
75.5	0.628	6.8	0.7	0.3	6.7	0.8	0.3
75.0	0.628	6.8	0.7	0.2	6.7	0.8	0.3
74.5	0.628	6.8	0.7	0.2	6.8	0.7	0.2
74.0	0.628	6.9	0.6	0.2	6.8	0.7	0.2
73.5	0.628	6.9	0.6	0.2	6.9	0.7	0.2
73.0	0.628	7.0	0.6	0.2	6.9	0.6	0.2
72.5	0.628	7.0	0.6	0.2	6.9	0.6	0.2
72.0	0.628	7.0	0.6	0.1	7.0	0.6	0.2
71.5	0.628	7.1	0.5	0.1	7.0	0.6	0.1
71.0	0.628	7.1	0.5	0.1	7.0	0.6	0.1
70.5	0.628	7.1	0.5	0.1	7.1	0.6	0.1
70.0	0.628	7.1	0.5	0.1	7.1	0.5	0.1
69.5	0.628	7.1	0.5	0.1	7.1	0.5	0.1
69.0	0.628	7.2	0.5	0.1	7.1	0.5	0.1
68.5	0.628	7.2	0.5	0.1	7.2	0.5	0.1
68.0	0.628	7.2	0.5	0.1	7.2	0.5	0.1
67.5	0.628	7.2	0.5	0.0	7.2	0.5	0.1
67.0	0.628	7.2	0.5	0.0	7.2	0.5	0.1
66.5	0.628	7.2	0.5	0.0	7.2	0.5	0.0
66.0	0.628	7.2	0.5	0.0	7.2	0.5	0.0

a/ Scenario D2 - City of Georgetown, Dove Springs Development Company, and Berry Creek Facilities
D2a1 - G.T. @ 4.0 MGD w/ 10/3/4; D.S. 1.0 MGD w/ 10/3/4; B.C. @ 3.0 MGD w/ 10/3/4
D2a2 - G.T. @ 4.0 MGD w/ 10/3/4; D.S. 2.4 MGD w/ 10/3/4; B.C. @ 1.6 MGD w/ 10/3/4

Figure V.16
 San Gabriel River - Segment 1248
 Dissolved Oxygen Concentrations Assuming City of Georgetown,
 Dove Springs Development, and Berry Creek WWTPs
 — Scenario D2 —

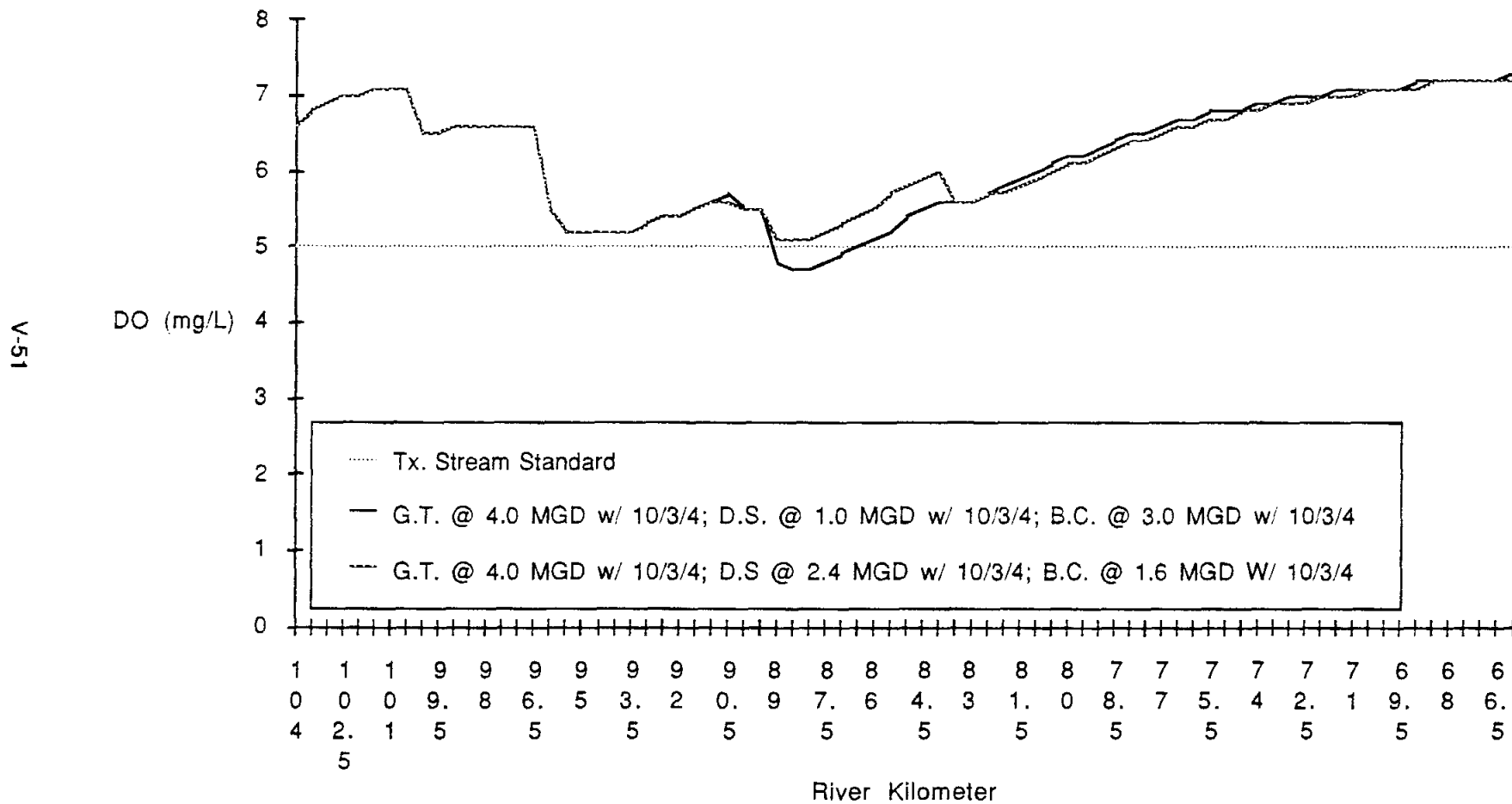
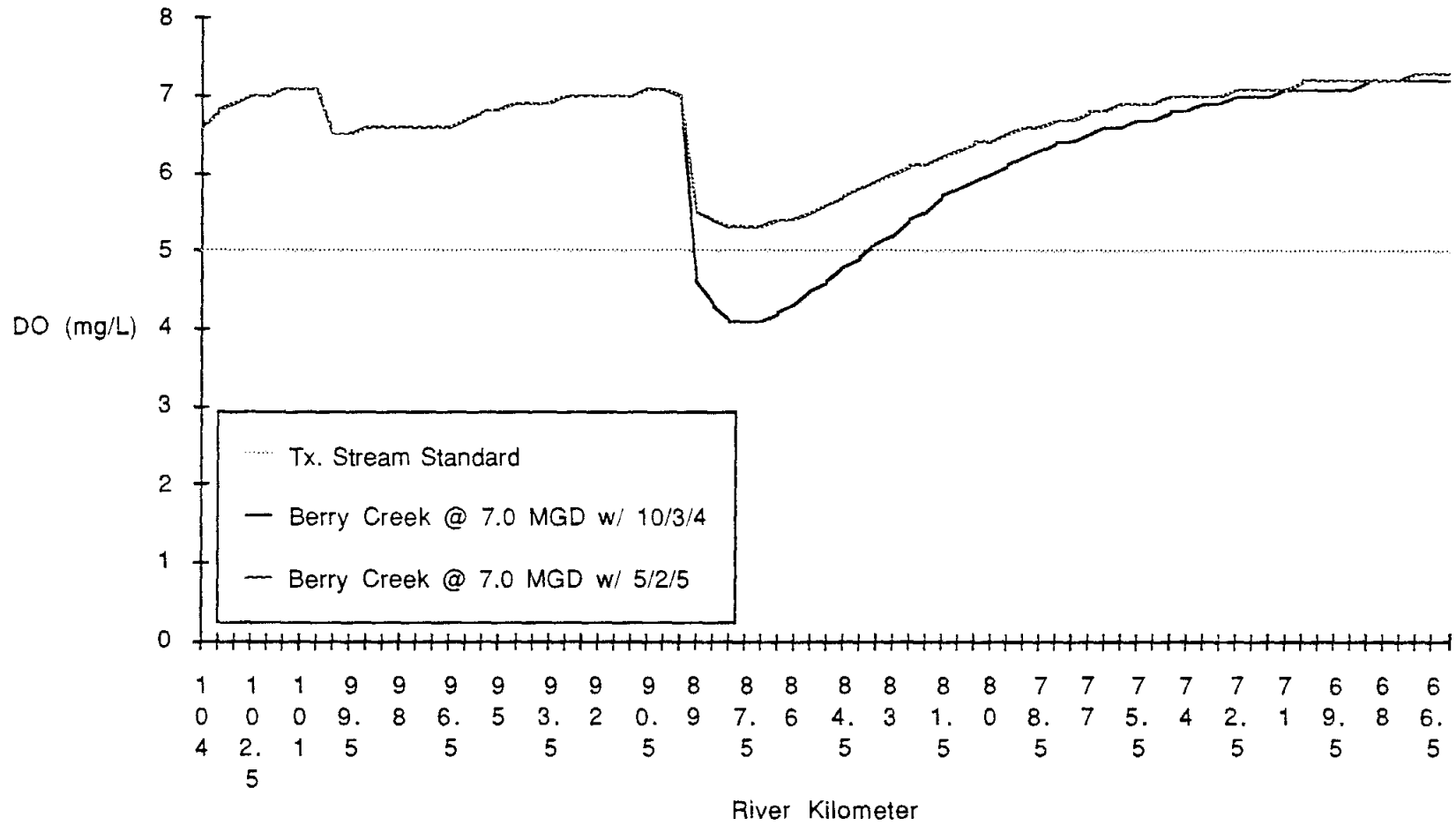

Table V.13
Simulation Scenario E - DO, BOD, and NH3 Concentrations a/

River Km	Flow, cms	Simulation Scenario E1			Simulation Scenario E2		
		DO, mg/L	BOD, mg/L	NH3, mg/L	DO, mg/L	BOD, mg/L	NH3, mg/L
104.0	0.007	6.6	0.6	0.2	6.6	0.6	0.2
103.5	0.007	6.8	0.4	0.2	6.8	0.4	0.2
103.0	0.007	6.9	0.3	0.2	6.9	0.3	0.2
102.5	0.007	7.0	0.4	0.1	7.0	0.4	0.1
102.0	0.007	7.0	0.4	0.1	7.0	0.4	0.1
101.5	0.007	7.1	0.4	0.0	7.1	0.4	0.0
101.0	0.007	7.1	0.5	0.0	7.1	0.5	0.0
100.5	0.007	7.1	0.5	0.0	7.1	0.5	0.0
100.0	0.047	6.5	1.0	0.1	6.5	1.0	0.1
99.5	0.070	6.5	1.0	0.2	6.5	1.0	0.2
99.0	0.094	6.6	0.9	0.2	6.6	0.9	0.2
98.5	0.117	6.6	0.9	0.2	6.6	0.9	0.2
98.0	0.141	6.6	0.9	0.2	6.6	0.9	0.2
97.5	0.164	6.6	0.8	0.2	6.6	0.8	0.2
97.0	0.197	6.6	0.7	0.2	6.6	0.7	0.2
96.5	0.221	6.6	0.6	0.2	6.6	0.6	0.2
96.0	0.233	6.7	0.8	0.2	6.7	0.8	0.2
95.5	0.233	6.8	0.9	0.2	6.8	0.9	0.2
95.0	0.233	6.8	0.7	0.2	6.8	0.7	0.2
94.5	0.233	6.9	0.6	0.2	6.9	0.6	0.2
94.0	0.233	6.9	0.8	0.2	6.9	0.8	0.2
93.5	0.233	6.9	0.8	0.2	6.9	0.8	0.2
93.0	0.233	7.0	0.7	0.2	7.0	0.7	0.2
92.5	0.233	7.0	0.7	0.2	7.0	0.7	0.2
92.0	0.233	7.0	0.7	0.2	7.0	0.7	0.2
91.5	0.233	7.0	0.7	0.2	7.0	0.7	0.2
91.0	0.233	7.0	0.7	0.2	7.0	0.7	0.2
90.5	0.233	7.1	0.7	0.2	7.1	0.7	0.2
90.0	0.233	7.1	0.6	0.2	7.1	0.6	0.2
89.5	0.233	7.0	0.5	0.2	7.0	0.5	0.2
89.0	0.558	4.6	5.4	1.7	5.5	2.9	1.2
88.5	0.571	4.3	4.8	1.6	5.4	2.7	1.1
88.0	0.585	4.1	4.4	1.5	5.3	2.4	1.1
87.5	0.585	4.1	4.0	1.4	5.3	2.2	1.0
87.0	0.585	4.1	3.7	1.4	5.3	2.1	1.0
86.5	0.585	4.2	3.3	1.3	5.4	1.9	1.0
86.0	0.585	4.3	3.1	1.3	5.4	1.8	0.9
85.5	0.585	4.5	2.8	1.2	5.5	1.6	0.9
85.0	0.585	4.6	2.6	1.1	5.6	1.5	0.9
84.5	0.585	4.8	2.4	1.1	5.7	1.4	0.8
84.0	0.585	4.9	2.2	1.0	5.8	1.3	0.8
83.5	0.585	5.1	2.0	1.0	5.9	1.2	0.7
83.0	0.585	5.2	1.9	0.9	6.0	1.2	0.7
82.5	0.585	5.4	1.7	0.8	6.1	1.1	0.7
82.0	0.585	5.5	1.6	0.8	6.1	1.0	0.6
81.5	0.585	5.7	1.5	0.7	6.2	1.0	0.6
81.0	0.585	5.8	1.4	0.7	6.3	0.9	0.6
80.5	0.585	5.9	1.3	0.6	6.4	0.9	0.5
80.0	0.585	6.0	1.2	0.6	6.4	0.8	0.5
79.5	0.585	6.1	1.1	0.6	6.5	0.8	0.4
79.0	0.585	6.2	1.1	0.5	6.6	0.7	0.4
78.5	0.585	6.3	1.0	0.5	6.6	0.7	0.4
78.0	0.585	6.4	1.0	0.4	6.7	0.7	0.4
77.5	0.585	6.4	0.9	0.4	6.7	0.7	0.3
77.0	0.585	6.5	0.9	0.4	6.8	0.6	0.3
76.5	0.585	6.6	0.8	0.3	6.8	0.6	0.3
76.0	0.585	6.6	0.8	0.3	6.9	0.6	0.3
75.5	0.585	6.7	0.7	0.3	6.9	0.6	0.2
75.0	0.585	6.7	0.7	0.3	6.9	0.6	0.2
74.5	0.585	6.8	0.7	0.2	7.0	0.5	0.2
74.0	0.585	6.8	0.6	0.2	7.0	0.5	0.2
73.5	0.585	6.9	0.6	0.2	7.0	0.5	0.2
73.0	0.585	6.9	0.6	0.2	7.0	0.5	0.2
72.5	0.585	7.0	0.6	0.2	7.1	0.5	0.1
72.0	0.585	7.0	0.6	0.2	7.1	0.5	0.1
71.5	0.585	7.0	0.5	0.1	7.1	0.5	0.1
71.0	0.585	7.1	0.5	0.1	7.1	0.5	0.1
70.5	0.585	7.1	0.5	0.1	7.2	0.5	0.1
70.0	0.585	7.1	0.5	0.1	7.2	0.5	0.1
69.5	0.585	7.1	0.5	0.1	7.2	0.4	0.1
69.0	0.585	7.1	0.5	0.1	7.2	0.4	0.1
68.5	0.585	7.2	0.5	0.1	7.2	0.4	0.1
68.0	0.585	7.2	0.5	0.1	7.2	0.4	0.0
67.5	0.585	7.2	0.5	0.1	7.2	0.4	0.0
67.0	0.585	7.2	0.5	0.0	7.3	0.4	0.0
66.5	0.585	7.2	0.5	0.0	7.3	0.4	0.0
66.0	0.585	7.2	0.4	0.0	7.3	0.4	0.0

a/ Scenario E - Berry Creek Plant Only
E1 - B.C. @ 7.0 MGD w/ 10/3/4
E2 - B.C. @ 7.0 MGD w/ 5/2/5

Figure V.17
 San Gabriel River - Segment 1248
 Dissolved Oxygen Concentrations Assuming Berry Creek WWTP Only
 — Scenario E —



V-53

Table V.14
Simulation Scenario F - DO, BOD, and NH3 Concentrations a/

River Km	Flow, cms	Simulation Scenario F1			Simulation Scenario F2		
		DO, mg/L	BOD, mg/L	NH3, mg/L	DO, mg/L	BOD, mg/L	NH3, mg/L
104.0	0.007	6.6	0.6	0.2	6.6	0.6	0.2
103.5	0.007	6.8	0.4	0.2	6.8	0.4	0.2
103.0	0.007	6.9	0.3	0.2	6.9	0.3	0.2
102.5	0.007	7.0	0.4	0.1	7.0	0.4	0.1
102.0	0.007	7.0	0.4	0.1	7.0	0.4	0.1
101.5	0.007	7.1	0.4	0.0	7.1	0.4	0.0
101.0	0.007	7.1	0.5	0.0	7.1	0.5	0.0
100.5	0.007	7.1	0.5	0.0	7.1	0.5	0.0
100.0	0.047	6.5	1.0	0.1	6.5	1.0	0.1
99.5	0.070	6.5	1.0	0.2	6.5	1.0	0.2
99.0	0.094	6.6	0.9	0.2	6.6	0.9	0.2
98.5	0.117	6.6	0.9	0.2	6.6	0.9	0.2
98.0	0.141	6.6	0.9	0.2	6.6	0.9	0.2
97.5	0.164	6.6	0.8	0.2	6.6	0.8	0.2
97.0	0.187	6.6	0.7	0.2	6.6	0.7	0.2
96.5	0.221	6.6	0.6	0.2	6.6	0.6	0.2
96.0	0.233	6.7	0.8	0.2	6.7	0.8	0.2
95.5	0.233	6.8	0.9	0.2	6.8	0.9	0.2
95.0	0.233	6.9	0.7	0.2	6.9	0.7	0.2
94.5	0.233	6.9	0.6	0.2	6.9	0.6	0.2
94.0	0.233	6.9	0.8	0.2	6.9	0.8	0.2
93.5	0.233	6.9	0.8	0.2	6.9	0.8	0.2
93.0	0.233	7.0	0.7	0.2	7.0	0.7	0.2
92.5	0.233	7.0	0.7	0.2	7.0	0.7	0.2
92.0	0.233	7.0	0.7	0.2	7.0	0.7	0.2
91.5	0.233	7.0	0.7	0.2	7.0	0.7	0.2
91.0	0.233	7.0	0.7	0.2	7.0	0.7	0.2
90.5	0.233	7.1	0.7	0.2	7.1	0.7	0.2
90.0	0.233	7.1	0.6	0.2	7.1	0.6	0.2
89.5	0.233	7.0	0.5	0.2	7.0	0.5	0.2
89.0	0.251	7.0	0.5	0.1	7.0	0.5	0.1
88.5	0.265	7.0	0.5	0.1	7.0	0.5	0.1
88.0	0.278	7.0	0.5	0.1	7.0	0.5	0.1
87.5	0.278	7.0	0.5	0.1	7.0	0.5	0.1
87.0	0.278	7.1	0.5	0.1	7.1	0.5	0.1
86.5	0.278	7.1	0.5	0.1	7.1	0.5	0.1
86.0	0.278	7.1	0.5	0.1	7.1	0.5	0.1
85.5	0.278	7.1	0.5	0.1	7.1	0.5	0.1
85.0	0.278	7.1	0.4	0.1	7.1	0.4	0.1
84.5	0.628	4.7	5.5	1.6	5.6	3.0	1.1
84.0	0.628	4.3	5.0	1.8	5.4	2.7	1.1
83.5	0.628	4.0	4.6	1.5	5.3	2.5	1.1
83.0	0.628	4.0	4.3	1.5	5.3	2.3	1.1
82.5	0.628	4.0	3.9	1.4	5.3	2.2	1.0
82.0	0.628	4.0	3.6	1.4	5.3	2.0	1.0
81.5	0.628	4.2	3.3	1.3	5.4	1.9	1.0
81.0	0.628	4.3	3.1	1.3	5.5	1.7	0.9
80.5	0.628	4.4	2.8	1.2	5.5	1.6	0.9
80.0	0.628	4.6	2.6	1.1	5.6	1.5	0.9
79.5	0.628	4.8	2.4	1.1	5.7	1.4	0.8
79.0	0.628	4.9	2.2	1.0	5.8	1.3	0.8
78.5	0.628	5.1	2.1	1.0	5.9	1.2	0.7
78.0	0.628	5.2	1.9	0.9	6.0	1.2	0.7
77.5	0.628	5.4	1.8	0.8	6.1	1.1	0.7
77.0	0.628	5.5	1.7	0.8	6.1	1.0	0.6
76.5	0.628	5.6	1.5	0.7	6.2	1.0	0.6
76.0	0.628	5.7	1.4	0.7	6.3	0.9	0.5
75.5	0.628	5.8	1.4	0.7	6.4	0.9	0.5
75.0	0.628	6.0	1.3	0.6	6.4	0.8	0.5
74.5	0.628	6.1	1.2	0.6	6.5	0.8	0.5
74.0	0.628	6.2	1.1	0.5	6.6	0.8	0.4
73.5	0.628	6.2	1.1	0.5	6.6	0.7	0.4
73.0	0.628	6.3	1.0	0.5	6.7	0.7	0.4
72.5	0.628	6.4	0.9	0.4	6.7	0.7	0.3
72.0	0.628	6.5	0.9	0.4	6.8	0.6	0.3
71.5	0.628	6.5	0.8	0.4	6.8	0.6	0.3
71.0	0.628	6.6	0.8	0.3	6.8	0.6	0.3
70.5	0.628	6.7	0.8	0.3	6.9	0.6	0.2
70.0	0.628	6.7	0.7	0.3	6.9	0.6	0.2
69.5	0.628	6.8	0.7	0.3	6.9	0.5	0.2
69.0	0.628	6.8	0.7	0.2	7.0	0.5	0.2
68.5	0.628	6.9	0.7	0.2	7.0	0.5	0.2
68.0	0.628	6.9	0.6	0.2	7.0	0.5	0.2
67.5	0.628	6.9	0.6	0.2	7.1	0.5	0.1
67.0	0.628	7.0	0.6	0.2	7.1	0.5	0.1
66.5	0.628	7.0	0.6	0.1	7.1	0.5	0.1
66.0	0.628	7.0	0.6	0.1	7.1	0.5	0.1

a/ Scenario F - Mankin's Crossing Plant Only
F1 - M.X. @ 8.0 MGD w/ 10/3/4
F2 - M.X. @ 8.0 MGD w/ 5/25

Figure V.18
 San Gabriel River - Segment 1248
 Dissolved Oxygen Concentrations Assuming Mankin's Crossing WWTP Only
 — Scenario F —

V-55

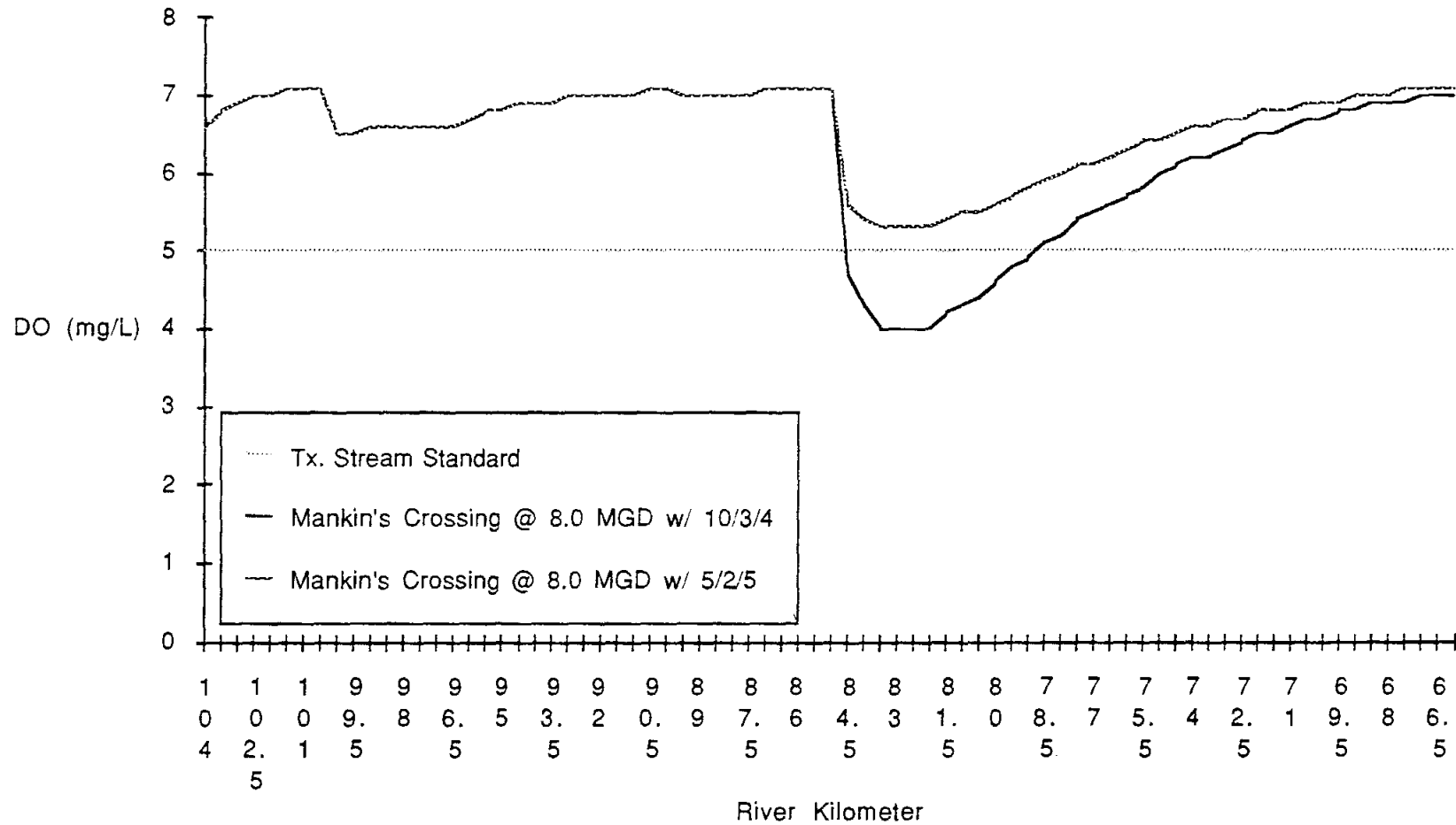

Table V.15
Simulation Scenario G - DO, BOD, and NH3 Concentrations a/

River Km	Flow, cms	Simulation Scenario G		
		DO, mg/L	BOD, mg/L	NH3, mg/L
104.0	0.007	6.8	0.6	0.2
103.5	0.007	6.8	0.4	0.2
103.0	0.007	6.9	0.3	0.2
102.5	0.007	7.0	0.4	0.1
102.0	0.007	7.0	0.4	0.1
101.5	0.007	7.1	0.4	0.0
101.0	0.007	7.1	0.5	0.0
100.5	0.007	7.1	0.5	0.0
100.0	0.047	6.5	1.0	0.1
99.5	0.070	6.5	1.0	0.2
99.0	0.094	6.6	0.9	0.2
98.5	0.117	6.6	0.9	0.2
98.0	0.141	6.6	0.9	0.2
97.5	0.164	6.6	0.8	0.2
97.0	0.197	6.6	0.7	0.2
96.5	0.221	6.6	0.6	0.2
96.0	0.343	5.8	3.6	1.1
95.5	0.343	5.6	3.3	1.1
95.0	0.343	5.6	3.1	1.1
94.5	0.343	5.7	2.8	1.1
94.0	0.343	5.6	2.8	1.1
93.5	0.343	5.7	2.7	1.1
93.0	0.343	5.8	2.5	1.1
92.5	0.343	5.8	2.4	1.1
92.0	0.343	5.9	2.2	1.0
91.5	0.343	6.0	2.1	1.0
91.0	0.343	6.0	2.0	1.0
90.5	0.343	6.1	1.9	1.0
90.0	0.343	6.0	1.6	0.9
89.5	0.343	6.0	1.4	0.8
89.0	0.448	5.3	2.8	1.2
88.5	0.462	5.3	2.5	1.1
88.0	0.475	5.3	2.3	1.0
87.5	0.475	5.3	2.1	0.9
87.0	0.475	5.4	1.9	0.9
86.5	0.475	5.5	1.7	0.8
86.0	0.475	5.7	1.6	0.8
85.5	0.475	5.8	1.5	0.7
85.0	0.475	5.9	1.3	0.7
84.5	0.607	5.3	3.0	1.1
84.0	0.607	5.2	2.8	1.1
83.5	0.607	5.1	2.6	1.0
83.0	0.607	5.2	2.4	1.0
82.5	0.607	5.2	2.2	0.9
82.0	0.607	5.3	2.0	0.9
81.5	0.607	5.4	1.9	0.8
81.0	0.607	5.5	1.8	0.8
80.5	0.607	5.7	1.6	0.7
80.0	0.607	5.8	1.5	0.7
79.5	0.607	5.9	1.4	0.6
79.0	0.607	6.0	1.3	0.6
78.5	0.607	6.1	1.2	0.5
78.0	0.607	6.2	1.2	0.5
77.5	0.607	6.2	1.1	0.5
77.0	0.607	6.3	1.0	0.4
76.5	0.607	6.4	1.0	0.4
76.0	0.607	6.5	0.9	0.4
75.5	0.607	6.5	0.9	0.4
75.0	0.607	6.6	0.8	0.3
74.5	0.607	6.7	0.8	0.3
74.0	0.607	6.7	0.7	0.3
73.5	0.607	6.8	0.7	0.3
73.0	0.607	6.8	0.7	0.2
72.5	0.607	6.9	0.7	0.2
72.0	0.607	6.9	0.6	0.2
71.5	0.607	6.9	0.6	0.2
71.0	0.607	7.0	0.6	0.2
70.5	0.607	7.0	0.6	0.1
70.0	0.607	7.0	0.6	0.1
69.5	0.607	7.1	0.5	0.1
69.0	0.607	7.1	0.5	0.1
68.5	0.607	7.1	0.5	0.1
68.0	0.607	7.1	0.5	0.1
67.5	0.607	7.2	0.5	0.1
67.0	0.607	7.2	0.5	0.1
66.5	0.607	7.2	0.5	0.1
66.0	0.607	7.2	0.5	0.0

a/ Scenario G - City of Georgetown, Berry Creek, and Mankin's Crossing Plants Only.
G.T. @ 2.5 MGD w/ 10/3/4; B.C. @ 2 MGD w/ 10/3/4;
M.X. @ 3.5 MGD w/ 10/3/4

Table V.16
Simulation Scenario H - DO, BOD, and NH3 Concentrations a/

River Km	Flow, cms	Simulation Scenario H		
		DO, mg/L	BOD, mg/L	NH3, mg/L
104.0	0.007	6.8	0.6	0.2
103.5	0.007	6.8	0.4	0.2
103.0	0.007	6.9	0.3	0.2
102.5	0.007	7.0	0.4	0.1
102.0	0.007	7.0	0.4	0.1
101.5	0.007	7.1	0.4	0.0
101.0	0.007	7.1	0.5	0.0
100.5	0.007	7.1	0.5	0.0
100.0	0.047	6.5	1.0	0.1
99.5	0.070	6.5	1.0	0.2
99.0	0.094	6.6	0.9	0.2
98.5	0.117	6.6	0.9	0.2
98.0	0.141	6.6	0.9	0.2
97.5	0.164	6.6	0.8	0.2
97.0	0.197	6.6	0.7	0.2
96.5	0.221	6.6	0.6	0.2
96.0	0.343	5.8	3.6	1.1
95.5	0.343	5.6	3.3	1.1
95.0	0.343	5.6	3.1	1.1
94.5	0.343	5.7	2.8	1.1
94.0	0.343	5.6	2.8	1.1
93.5	0.343	5.7	2.7	1.1
93.0	0.343	5.8	2.5	1.1
92.5	0.343	5.8	2.4	1.1
92.0	0.343	5.9	2.2	1.0
91.5	0.343	6.0	2.1	1.0
91.0	0.343	6.0	2.0	1.0
90.5	0.343	6.1	1.9	1.0
90.0	0.343	6.0	1.6	0.9
89.5	0.343	6.0	1.4	0.8
89.0	0.361	6.0	1.3	0.7
88.5	0.374	6.1	1.2	0.6
88.0	0.388	6.2	1.1	0.6
87.5	0.388	6.3	1.0	0.5
87.0	0.388	6.4	0.9	0.5
86.5	0.388	6.4	0.8	0.4
86.0	0.388	6.5	0.8	0.4
85.5	0.388	6.6	0.7	0.4
85.0	0.388	6.7	0.7	0.3
84.5	0.628	5.8	4.1	1.0
84.0	0.628	5.4	3.7	0.9
83.5	0.628	5.2	3.4	0.9
83.0	0.628	5.1	3.2	0.9
82.5	0.628	5.1	2.9	0.8
82.0	0.628	5.1	2.7	0.8
81.5	0.628	5.2	2.5	0.8
81.0	0.628	5.3	2.3	0.7
80.5	0.628	5.4	2.1	0.7
80.0	0.628	5.5	2.0	0.7
79.5	0.628	5.6	1.8	0.6
79.0	0.628	5.7	1.7	0.6
78.5	0.628	5.8	1.6	0.6
78.0	0.628	5.9	1.5	0.5
77.5	0.628	6.0	1.4	0.5
77.0	0.628	6.1	1.3	0.5
76.5	0.628	6.2	1.2	0.4
76.0	0.628	6.3	1.1	0.4
75.5	0.628	6.4	1.1	0.4
75.0	0.628	6.4	1.0	0.4
74.5	0.628	6.5	1.0	0.3
74.0	0.628	6.6	0.9	0.3
73.5	0.628	6.6	0.9	0.3
73.0	0.628	6.7	0.8	0.3
72.5	0.628	6.7	0.8	0.3
72.0	0.628	6.8	0.8	0.2
71.5	0.628	6.8	0.7	0.2
71.0	0.628	6.9	0.7	0.2
70.5	0.628	6.9	0.7	0.2
70.0	0.628	6.9	0.6	0.2
69.5	0.628	7.0	0.6	0.2
69.0	0.628	7.0	0.6	0.1
68.5	0.628	7.0	0.6	0.1
68.0	0.628	7.1	0.6	0.1
67.5	0.628	7.1	0.5	0.1
67.0	0.628	7.1	0.5	0.1
66.5	0.628	7.1	0.5	0.1
66.0	0.628	7.1	0.5	0.1

a/ Scenario H - City of Georgetown and Manlin's Creek Plants Only
G.T. @ 2.5 MGD w/ 10/3/4 and M.X. @ 5.5 MGD w/ 10/2/6

Figure V.20
 San Gabriel River - Segment 1248
 Dissolved Oxygen Concentrations Assuming
 City of Georgetown and Mankin's Crossing WWTPs Only
 — Scenario H —

V-59

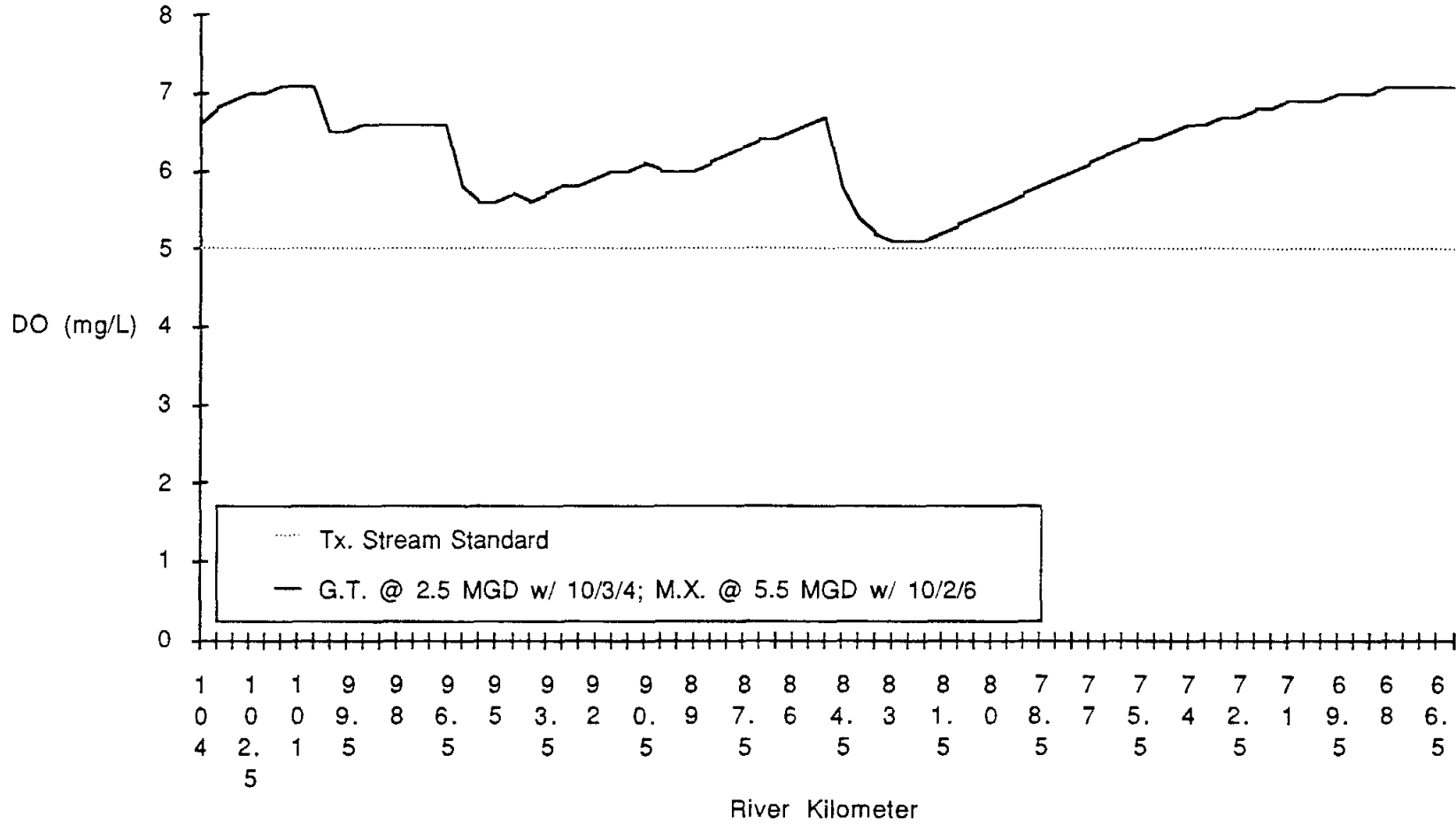

V.B.6 QUAL-TX Simulation Conclusions

The Texas Water Commission Wasteload Evaluation for Segment 1248 concluded:

- "The ultimate permitted treatment level with a 4 mg/L effluent dissolved oxygen requirement for the Georgetown WWTP allows for maintenance of the dissolved oxygen criterion in the San Gabriel River at flows of 1.8 MGD or less under critical summer conditions and for flows greater than 1.8 MGD under critical non-summer low flow conditions.
- "At discharges greater than 1.8 MGD during critical summer months, the 5 mg/L criterion may be attained in the San Gabriel River with nitrification at the Georgetown WWTP."

Simulations performed in accordance with this regional wastewater planning study substantiate both of these conclusions and add the following case-specific conclusions:

- The City of Georgetown could discharge up to approximately 4 MGD from the existing facility with a treatment level upgrade to 10/3/4 and installation of an outfall main to discharge effluent beyond the Edwards Aquifer recharge zone. The minimum DO, under summer critical low flow conditions, resulting from this discharge would be 5.2 mg/L. It is not likely that the City of Georgetown's treatment facility could be expanded beyond 4 MGD without requiring a treatment level of 5/2/5.
- With or without upgrading the City of Georgetown facility, the proposed Dove Springs WWTP could discharge 2.4 MGD at a treatment level of 10/3/4 without violating the main stem of the San Gabriel River (Segment 1248) minimum DO level of 5.0 mg/L under critical summer low flow conditions.
- Without upgrading the Georgetown facility to a treatment level of 10/3/4, the combined discharge of the Dove Springs Development Corporation and Mankin's Crossing facilities at 5.5 MGD (a total segment treatment capacity of 8 MGD) would result in violation of the 5.0 mg/L minimum DO criterion. The minimum predicted DO concentration is 4.3 mg/L.
- With the City of Georgetown facility upgraded to a treatment level of 10/3/4, Dove Springs Development Corporation could discharge up to 2.4 MGD and the Mankin's Crossing facility could discharge up to 3.0 MGD, both at a treatment level of 10/3/4, without violating the state criterion.
- Without upgrading the Georgetown facility to a treatment level of 10/3/4 a combined discharge of Dove Springs Development Corporation, Mankin's Crossing and Berry Creek facilities at 5.5 MGD (a total treatment capacity of 8 MGD) would result in violation of the 5.0 mg/L minimum DO criterion. The minimum predicted DO concentration is 4.3 mg/L.

- With the City of Georgetown facility upgraded to a treatment level of 10/3/4, Dove Springs Development Corporation could discharge up to 1 MGD, a Berry Creek facility up to 2 MGD, and the Mankin's Crossing facility could discharge up to 2.5 MGD, all at a treatment level of 10/3/4, without violating the state criterion. The minimum predicted DO concentration is 5.1 mg/L.
- A 7 MGD facility located at Berry Creek or an 8 MGD facility located at Mankin's Crossing would require a treatment level of 5/2/5 to maintain DO levels above 5 mg/L at summer critical low flow conditions.

V.C Water Quality Simulations - Segment 1247: Lake Granger

As with stream water quality models, there is a myriad of empirical and mechanistic models available for prediction of the long-term eutrophication impacts to an impoundment resulting from a proposed activity. And, as with stream water quality models, selection of the most appropriate model is often a function of availability of data; the more data available, the more sophisticated the model that can be used.

For this study, a two phased approach to the eutrophication analysis was used. First, the trophic state of Lake Granger was calculated, based on either nitrogen or phosphorus as the limiting nutrient, for conditions with and without a Georgetown Regional WWTP in place. These loadings were compared with computed boundary condition loadings for oligotrophic-mesotrophic and mesotrophic-eutrophic conditions. Second, the mean water column concentrations of nitrogen and phosphorus were computed for Lake Granger and resulting chlorophyll-a concentrations were computed using regressions developed from the U.S. EPA National Eutrophication Survey of Texas lakes. These concentrations were compared with the observed levels in other Texas lakes and the potential for eutrophic conditions in Lake Granger predicted.

V.C.1 Mass Loading Rate Method

V.C.1.a Model Description

Numerous investigators have related the annual areal mass loadings ($\text{gm}/\text{m}^2/\text{yr}$) of nitrogen and phosphorus to the trophic state of reservoirs throughout the United States and Europe (Vollenweider, 1968 and 1975, Chapra and Rechow, 1983, U.S. EPA, 1983). Vollenweider's work is the most widely recognized and used for this type of eutrophication analysis.

Vollenweider's original eutrophication criteria (1968) were developed for U.S. and European lakes predominantly in the northern temperate zones (Table V.17) but were modified to include a broader cross-section of U.S. lakes (Figure V.21). Texas impoundments, however, are often light limited and do not respond as readily to high nutrient loads as impoundments in other regions of the country. For this reason, eutrophication criteria were doubled and used only as a guideline of potential eutrophication.

Table V.17
Permissible Loading Levels for Total Nitrogen
and Total Phosphorus (Biochemically Active)
(gm/m²/yr)

Mean Depth (m), up to	Permissible Loadings, up to		Dangerous Loading, in excess of	
	N	P	N	P
5	1.0	0.07	2.0	0.13
10	1.5	0.10	3.0	0.20
50	4.0	0.25	8.0	0.50
100	6.0	0.40	12.0	0.80
150	7.5	0.50	15.0	1.00
200	9.0	0.60	18.0	1.20

Source: Engineering Approaches for Lake Management - Volume I: Data Analysis and Empirical Modeling.

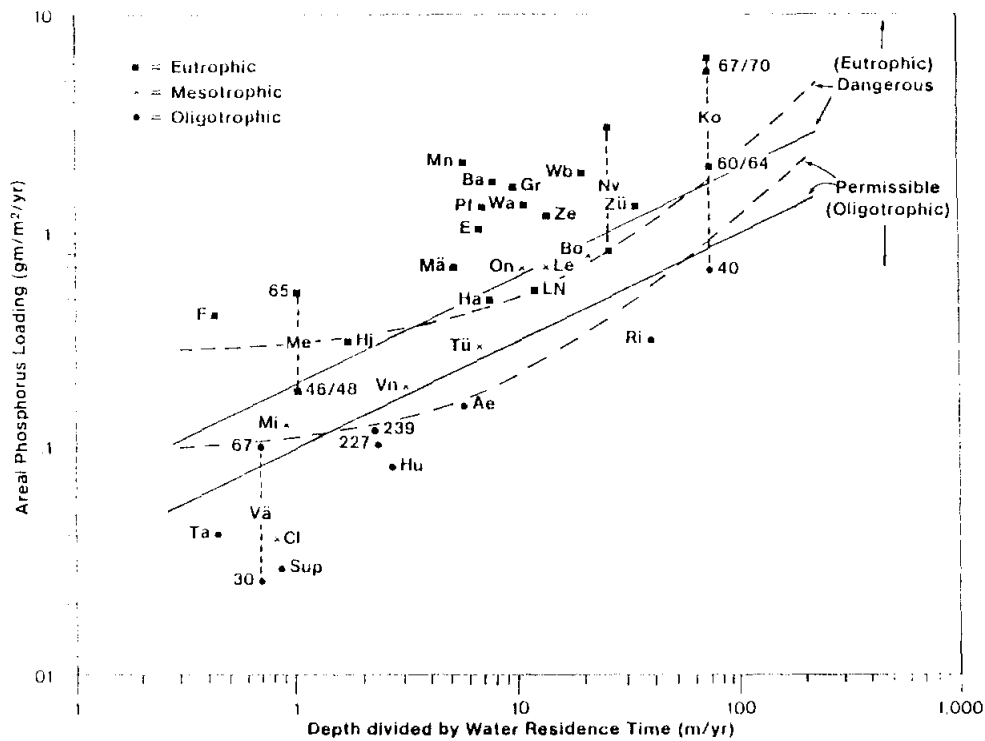

Figure V.21 Vollenweider's (1975) Phosphorus Loading Plot Revised to Include the Effects of Flushing on Trophic State.

The primary equations in annual average nutrient mass loading calculation is:

$$\omega_n = (P_n + P_p)/A \quad \text{and} \quad \omega_p = (N_n + N_p)/A \quad [V-11], [V-12]$$

where ω = Annual average areal loading, gm/m²/yr,
 P_n = Total annual phosphorus load from point sources, gm/yr,
 P_p = Total annual phosphorus load from non-point sources, gm/yr,
 N_n = Total annual nitrogen load from point sources, gm/yr,
 N_p = Total annual nitrogen load from non-point sources, gm/yr, and
 A = Surface area of the impoundment.

Based on the work by Vollenweider and others, trophic boundaries have been established between oligotrophic - mesotrophic and mesotrophic - eutrophic systems.

$$\omega'_1 = \alpha (z_{avg} \cdot \rho + v_s) \quad \text{and} \quad \omega'_2 = \beta (z_{avg} \cdot \rho + v_s) \quad [V-13], [V-14]$$

where ω'_1 = Oligotrophic - mesotrophic boundary annual areal loading, gm/m²/yr,
 ω'_2 = Mesotrophic - eutrophic boundary annual areal loading, gm/m²/yr,
 α and β = Boundary water column concentration constants, mg/L,
 z_{avg} = Mean reservoir depth, meters,
 ρ = Inverse of hydraulic retention time, 1/yr, and
 v_s = Net sedimentation rate, m/yr.

Accepted ranges of boundary constants are: $\alpha = 0.010 - 0.020$ mg/L and $\beta = 0.020 - 0.030$ mg/L for phosphorus and $\alpha = 0.10 - 0.20$ mg/L and $\beta = 0.20 - 0.40$ mg/L for nitrogen. A typical settling rate for phosphorus is $v_{sp} = 12.4$ m/yr and a typical range of settling rates given for nitrogen is $v_{sn} = 10 - 16$ m/yr.

V.C.1.b Simulation Assumptions

The following assumptions were applied to the Lake Granger eutrophication simulations:

- Flows into and out of the impoundment consist of annual average flows as recorded by the U.S. Geological Survey (USGS Stations No.08105300 near Weir and No. 08105700 near Lanesport), corrected for intervening drainage area contributions. Hydraulic residence time of the impoundment was computed using monthly calculated inflows and outflows, recorded lake content (USGS Station No. 08105600), and computed monthly net lake evaporation.
- The proposed Georgetown Regional Wastewater Facility(ies) will operate at a maximum of 7 - 8 MGD with an effluent total phosphorus concentration of approximately 10 mg/L, 80% of which is ortho-phosphate (PO₄-P). The WWTP effluent total inorganic nitrogen entering the impound-

ment will be the sum of NH_3 , NO_2 , and NO_3 as predicted by the QUAL-TX simulations for Reach No. 29 Element No. 96 (approximately 38 Km downstream of the proposed discharge point).

- Phosphorus water column trophic state boundary concentrations are $\alpha = 0.020$ mg/L and $\beta = 0.040$ mg/L. Nitrogen water column trophic state boundary concentrations are $\alpha = 0.20$ mg/L and $\beta = 0.40$ mg/L. These are double the normally accepted Vollenweider boundary values.
- Phosphorus settling rate is 12.4 m/yr: Nitrogen settling rate is 16 m/yr.
- Non-point contributions of phosphorus at background levels recommended in the QUAL-TX Model documentation: $[\text{P}] = 0.020$ mg/L and $[\text{N}] = 0.10$ mg/L.

V.C.1.c Input Data

The input data required for the empirical approach to eutrophication analysis are summarized below.

- Drainage area feeding Lake Granger = 730 mi² (including drainage area of Lake Georgetown)
- Lake Geometry

Volume	V =	65,510 af (80,805,028 m ³)
Surface Area	A =	4,400 ac (17,805,585 m ²)
Depth	z_{avg} =	5.91 m
Outflow Rate	Q =	279 cfs (248,998,795 m ³ /yr)

- Nonpoint Source Nutrient Loadings to Lake Granger

Phosphorus

$$\begin{aligned} \text{Non-point Sources} &= (0.020 \text{ mg/L})(246,636,272 \text{ m}^3/\text{yr})(10^{-6} \text{ kg/mg})(10^3 \text{ L/m}^3) \\ &= 4,933 \text{ kg/yr} \end{aligned}$$

Nitrogen

$$\begin{aligned} \text{Non-point Sources} &= (0.10 \text{ mg/L})(246,636,272 \text{ m}^3/\text{yr})(10^{-6} \text{ kg/mg})(10^3 \text{ L/m}^3) \\ &= 24,664 \text{ kg/yr} \end{aligned}$$

- Point Source Nutrient Loadings Under 1988 Discharge and Treatment Levels

Phosphorus

$$\begin{aligned} \text{Point Source} &= (8.0 \text{ mg/L})(0.07492 \text{ m}^3/\text{sec})(31,536,000 \text{ sec/yr}) \\ &\quad (10^{-6} \text{ kg/mg})(10^3 \text{ L/m}^3) \\ &= 18,900 \text{ kg/yr} \end{aligned}$$

Nitrogen

$$\begin{aligned} \text{Point Source} &= (7.14 \text{ mg/L})(0.07492 \text{ m}^3/\text{sec})(31,536,000 \text{ sec/yr}) \\ &\quad (10^{-6} \text{ kg/mg})(10^3 \text{ L/m}^3) \\ &= 16,868 \text{ kg/yr} \end{aligned}$$

- Point Source Nutrient Loadings Under Projected 2030 Discharge and Treatment Levels

Phosphorus

$$\begin{aligned} \text{Point Source} &= (8.0 \text{ mg/L})(0.30667 \text{ m}^3/\text{sec})(31,536,000 \text{ sec/yr}) \\ &\quad (10^{-6} \text{ kg/mg})(10^3 \text{ L/m}^3) \\ &= 77,369 \text{ kg/yr} \end{aligned}$$

Nitrogen

$$\begin{aligned} \text{Point Source} &= (10.59 \text{ mg/L})(0.30667 \text{ m}^3/\text{sec})(31,536,000 \text{ sec/yr}) \\ &\quad (10^{-6} \text{ kg/mg})(10^3 \text{ L/m}^3) \\ &= 102,417 \text{ kg/yr} \end{aligned}$$

V.C.1.d Eutrophication Potential Calculations

Hydraulic Retention Time

Without a Georgetown WWTP

$$\tau_{w/o} = V/Q = 80,805,028 \text{ m}^3/246,636,272 \text{ m}^3/\text{yr} = 0.328 \text{ yrs}$$

$$\rho_{w/o} = 1/\tau = 1/0.328 \text{ yrs} = 3.052/\text{yr}$$

With Georgetown's Existing WWTP - 1988

$$\tau_{w/ (1988)} = V/Q = 80,805,028 \text{ m}^3/248,998,795 \text{ m}^3/\text{yr} = 0.325 \text{ yrs}$$

$$\rho_{w/ (1988)} = 1/\tau = 1/0.325 \text{ yrs} = 3.081/\text{yr}$$

With a Georgetown Regional System - 2030

$$\tau_{w/ (2030)} = V/Q = 80,805,028 \text{ m}^3/256,307,417 \text{ m}^3/\text{yr} = 0.315 \text{ yrs}$$

$$\rho_{w/ (2030)} = 1/\tau = 1/0.315 \text{ yrs} = 3.170/\text{yr}$$

Phosphorus Trophic Boundary Loadings

Without Georgetown

$$\begin{aligned} \omega'_{p1w/o} &= (0.020 \text{ mg/L}) [(5.91 \text{ m})(3.052/\text{yr}) + 12.4 \text{ m/yr}] = 0.609 \text{ gm/m}^2/\text{yr} \\ &= (0.609 \text{ gm/m}^2/\text{yr})(10^{-3} \text{ kg/gm})(17,805,585 \text{ m}^2) = 10,839 \text{ kg/yr} \end{aligned}$$

$$\begin{aligned} \omega'_{p2w/o} &= (0.040 \text{ mg/L}) [(5.91 \text{ m})(3.052/\text{yr}) + 12.4 \text{ m/yr}] = 1.217 \text{ gm/m}^2/\text{yr} \\ &= (1.217 \text{ gm/m}^2/\text{yr})(10^{-3} \text{ kg/gm})(17,805,585 \text{ m}^2) = 21,678 \text{ kg/yr} \end{aligned}$$

With Georgetown's Existing WWTP - 1988

$$\begin{aligned} \omega'_{p1w/ (1988)} &= (0.020 \text{ mg/L}) [(5.91 \text{ m})(3.081/\text{yr}) + 12.4 \text{ m/yr}] = 0.612 \text{ gm/m}^2/\text{yr} \\ &= (0.612 \text{ gm/m}^2/\text{yr})(10^{-3} \text{ kg/gm})(17,805,585 \text{ m}^2) = 10,900 \text{ kg/yr} \end{aligned}$$

$$\begin{aligned} \omega'_{p2w/ (1988)} &= (0.040 \text{ mg/L}) [(5.91 \text{ m})(3.081/\text{yr}) + 12.4 \text{ m/yr}] = 1.224 \text{ gm/m}^2/\text{yr} \\ &= (1.224 \text{ gm/m}^2/\text{yr})(10^{-3} \text{ kg/gm})(17,805,585 \text{ m}^2) = 21,800 \text{ kg/yr} \end{aligned}$$

With a Georgetown Regional System - 2030

$$\begin{aligned} \omega'_{p1w/ (2030)} &= (0.020 \text{ mg/L}) [(5.91 \text{ m})(3.170/\text{yr}) + 12.4 \text{ m/yr}] = 0.623 \text{ gm/m}^2/\text{yr} \\ &= (0.623 \text{ gm/m}^2/\text{yr})(10^{-3} \text{ kg/gm})(17,805,585 \text{ m}^2) = 11,088 \text{ kg/yr} \end{aligned}$$

$$\begin{aligned}\omega'_{p2w/2030} &= (0.040 \text{ mg/L}) [(5.91 \text{ m})(3.170/\text{yr}) + 12.4 \text{ m/yr}] = 1.224 \text{ gm/m}^2/\text{yr} \\ &= (1.224 \text{ gm/m}^2/\text{yr})(10^{-3} \text{ kg/gm})(17,805,585 \text{ m}^2) = 22,175 \text{ kg/yr}\end{aligned}$$

Nitrogen Trophic Boundary Loadings

Without Georgetown

$$\begin{aligned}\omega'_{n1w/o} &= (0.20 \text{ mg/L}) [(5.91 \text{ m})(3.052/\text{yr}) + 16 \text{ m/yr}] = 6.807 \text{ gm/m}^2/\text{yr} \\ &= (6.807 \text{ gm/m}^2/\text{yr})(10^{-3} \text{ kg/gm})(17,805,585 \text{ m}^2) = 121,211 \text{ kg/yr}\end{aligned}$$

$$\begin{aligned}\omega'_{n2w/o} &= (0.40 \text{ mg/L}) [(5.91 \text{ m})(3.052/\text{yr}) + 16 \text{ m/yr}] = 13.615 \text{ gm/m}^2/\text{yr} \\ &= (13.615 \text{ gm/m}^2/\text{yr})(10^{-3} \text{ kg/gm})(17,805,585 \text{ m}^2) = 242,422 \text{ kg/yr}\end{aligned}$$

With Georgetown's Existing WWTP - 1988

$$\begin{aligned}\omega'_{n1w/1988} &= (0.20 \text{ mg/L}) [(5.91 \text{ m})(3.081/\text{yr}) + 16 \text{ m/yr}] = 6.842 \text{ gm/m}^2/\text{yr} \\ &= (6.842 \text{ gm/m}^2/\text{yr})(10^{-3} \text{ kg/gm})(17,805,585 \text{ m}^2) = 121,821 \text{ kg/yr}\end{aligned}$$

$$\begin{aligned}\omega'_{n2w/1988} &= (0.40 \text{ mg/L}) [(5.91 \text{ m})(3.081/\text{yr}) + 16 \text{ m/yr}] = 13.681 \text{ gm/m}^2/\text{yr} \\ &= (13.681 \text{ gm/m}^2/\text{yr})(10^{-3} \text{ kg/gm})(17,805,585 \text{ m}^2) = 242,642 \text{ kg/yr}\end{aligned}$$

With a Georgetown Regional System - 2030

$$\begin{aligned}\omega'_{n1w/2030} &= (0.20 \text{ mg/L}) [(5.91 \text{ m})(3.170/\text{yr}) + 16 \text{ m/yr}] = 6.947 \text{ gm/m}^2/\text{yr} \\ &= (6.947 \text{ gm/m}^2/\text{yr})(10^{-3} \text{ kg/gm})(17,805,585 \text{ m}^2) = 123,694 \text{ kg/yr}\end{aligned}$$

$$\begin{aligned}\omega'_{n2w/2030} &= (0.40 \text{ mg/L}) [(5.91 \text{ m})(3.170/\text{yr}) + 16 \text{ m/yr}] = 13.893 \text{ gm/m}^2/\text{yr} \\ &= (13.893 \text{ gm/m}^2/\text{yr})(10^{-3} \text{ kg/gm})(17,805,585 \text{ m}^2) = 247,388 \text{ kg/yr}\end{aligned}$$

Eutrophication Potential

The potential eutrophication impacts of the effluent from a Georgetown Regional WWTP on Lake Granger are evident from inspection of Table V.18.

Without the proposed Georgetown facility, the annual average areal loadings of phosphorus and nitrogen from the contributing drainage area (4,933 kg/yr and 24,664 kg/yr, respectively) are within the permissible limits for maintenance of an oligotrophic system. However, with the Georgetown WWTP, the annual average areal loadings of phosphorus and nitrogen are 23,833 kg/yr and 41,532 kg/yr in 1988 and 82,302 kg/yr and 127,081 kg/yr in 2030

V.C.2 Comparison of Loadings and Chlorophyll-a Concentrations with Those of Other Texas Lakes

Between 1973 and 1976 the U.S. EPA performed a national lake eutrophication survey in an attempt to correlate, among other things, mass loadings of nitrogen and phosphorus from point and non-point sources with chlorophyll-a concentrations in lakes (U.S. EPA, 1977). Hundreds of reservoirs across the United States were sampled for temperature, depth, conductivity, pH, dissolved oxygen, total phospho-

rus, kjeldahl nitrogen, dissolved ortho-phosphorus, ammonia-nitrogen, nitrite and nitrate-nitrogen, and heavy metals. Algal assays were performed to determine the limiting nutrient for each lake; in Texas 39 lakes were sampled (Tables V-19, V-20 and V-21). Each lake was ranked nationally according to median total phosphorus, median inorganic nitrogen, median secchi disk depth, mean chlorophyll-a, minimum DO and median ortho-phosphate concentrations.

Table V.18
Trophic State Indicators of Lake Granger Without
and With a Georgetown Regional Wastewater
Treatment Plant

Parameter	ω' (kg/yr)	Actual Loading ω (kg/yr) (Yr 1988)	ω/ω' (-) (Yr 1988)	Actual Loading ω (kg/yr) (Yr 2030)	ω/ω' (-) (Yr 2030)
Phosphorus					
p1w/o	10,839	4,933	0.46	4,933	0.46
p2w/o	21,678	4,933	0.23	4,933	0.23
p1w/ (1988)	10,900	23,833	2.19	-	-
p2w/ (1988)	21,800	23,833	1.09	-	-
p1w/ (2030)	11,287	-	-	82,302	7.27
p2w/ (2030)	22,175	-	-	82,302	3.78
Nitrogen					
n1w/o	121,211	24,664	0.20	24,664	0.20
n2w/o	242,422	24,664	0.10	24,664	0.10
n1w/ (1988)	121,821	42,532	0.34	-	-
n2w/ (1988)	243,642	42,532	0.17	-	-
n1w/ (2030)	123,694	-	-	127,081	1.03
n2w/ (2030)	247,388	-	-	127,081	0.51

Table V.19
Texas Lake Data

Lake Name	Median Tot-P mg/L	Median Inorg-N mg/L	Mean Chlor-a µg/L
Amistad Lake	0.013	0.500	2.042
Bastrop Lake	0.022	0.090	12.892
Bellon Reservoir	0.016	0.185	8.025
Braunig Lake	0.134	0.150	22.762
Brownwood Lake	0.027	0.100	4.887
Lake Buchanan	0.036	0.250	8.606
Caddo Lake	0.055	0.070	14.808
Calaveras Lake	0.038	0.060	22.500
Canyon Lake	0.010	0.450	2.500
Lake Colorado City	0.043	0.090	12.675
Corpus Christi Lake	0.113	0.130	19.756
Diversion Lake	0.025	0.080	15.867
Eagle Mountain Lake	0.024	0.070	5.662
Fort Phantom Hill Lake	0.060	0.105	6.317
Garza Little Elm Reservoir	0.045	0.380	14.156
Kemp Lake	0.023	0.110	10.217
Houston Lake	0.097	0.260	16.650
Lake of the Pines	0.031	0.090	12.919
Lavon Reservoir	0.063	0.180	5.400
Livingston Lake	0.196	0.555	16.112
Lyndon B. Johnson Lake	0.042	0.420	8.100
Medina Lake	0.010	0.600	12.944
Lake Meredith	0.021	0.070	3.037
Palestine Lake	0.031	0.180	10.619
Possum Kingdom Reservoir	0.023	0.070	9.495
San Angelo Reservoir	0.098	0.140	24.675
Sam Rayburn Reservoir	0.029	0.150	6.267
E. V. Spence Reservoir	0.036	0.080	11.775
Somerville Lake	0.053	0.115	24.491
Stamford Lake	0.073	0.060	18.457
Stillhouse Hollow Reservoir	0.018	0.160	3.917
Tawakoni Lake	0.046	0.100	18.246
Texarkana	0.106	0.120	19.119
Texoma Lake	0.042	0.160	12.493
Travis Lake	0.018	0.250	5.595
Trinidad Lake	0.389	0.110	24.300
Twin Buttes Reservoir	0.029	0.250	8.708
White River Reservoir	0.020	0.110	4.333
White River Reservoir	0.028	0.120	6.912

Source: U.S. Environmental Protection Agency National Eutrophication Survey.

Table V.20
Texas Lake Data
Sorted in Descending Order on Phosphorus

Lake Name	Median Tot-P mg/L	Median Inorg-N mg/L	Mean Chlor-a µg/L
Trinidad Lake	0.389	0.110	24.300
Livingston Lake	0.196	0.555	16.112
Braunig Lake	0.134	0.150	22.762
Corpus Christi Lake	0.113	0.130	19.756
Texarkana	0.106	0.120	19.119
San Angelo Reservoir	0.098	0.140	24.675
Houston Lake	0.097	0.260	16.650
Stamford Lake	0.073	0.060	18.457
Lavon Reservoir	0.063	0.180	5.400
Fort Phantom Hill Lake	0.060	0.105	6.317
Caddo Lake	0.055	0.070	14.808
Somerville Lake	0.053	0.115	24.491
Tawakoni Lake	0.046	0.100	18.246
Garza Little Elm Reservoir	0.045	0.380	14.156
Lake Colorado City	0.043	0.090	12.675
Texoma Lake	0.042	0.160	12.493
Lyndon B. Johnson Lake	0.042	0.420	8.100
Calaveras Lake	0.038	0.060	22.500
E. V. Spence Reservoir	0.036	0.080	11.775
Lake Buchanan	0.036	0.250	8.606
Palestine Lake	0.031	0.180	10.619
Lake of the Pines	0.031	0.090	12.919
Twin Buttes Reservoir	0.029	0.250	8.708
Sam Rayburn Reservoir	0.029	0.150	6.267
White River Reservoir	0.028	0.120	6.912
Brownwood Lake	0.027	0.100	4.887
Diversion Lake	0.025	0.080	15.867
Eagle Mountain Lake	0.024	0.070	5.662
Possum Kingdom Reservoir	0.023	0.070	9.495
Kemp Lake	0.023	0.110	10.217
Bastrop Lake	0.022	0.090	12.892
Lake Meredith	0.021	0.070	3.037
White River Reservoir	0.020	0.110	4.333
Travis Lake	0.018	0.250	5.595
Stillhouse Hollow Reservoir	0.018	0.160	3.917
Belton Reservoir	0.016	0.185	8.025
Amistad Lake	0.013	0.500	2.042
Medina Lake	0.010	0.600	12.944
Canyon Lake	0.010	0.450	2.500

Source: U.S. Environmental Protection Agency National Eutrophication Survey.

Table V.21
Texas Lake Data
Sorted in Descending Order on Chlorophyll-a

Lake Name	Median Tot-P mg/L	Median Inorg-N mg/L	Mean Chlor-a µg/L
San Angelo Reservoir	0.098	0.140	24.675
Somerville Lake	0.053	0.115	24.491
Trinidad Lake	0.389	0.110	24.300
Braunig Lake	0.134	0.150	22.762
Calaveras Lake	0.038	0.060	22.500
Corpus Christi Lake	0.113	0.130	19.756
Texarkana	0.106	0.120	19.119
Stamford Lake	0.073	0.060	18.457
Tawakoni Lake	0.046	0.100	18.246
Houston Lake	0.097	0.260	16.650
Livingston Lake	0.196	0.555	16.112
Diversion Lake	0.025	0.080	15.867
Caddo Lake	0.055	0.070	14.808
Garza Little Elm Reservoir	0.045	0.380	14.156
Medina Lake	0.010	0.600	12.944
Lake of the Pines	0.031	0.090	12.919
Bastrop Lake	0.022	0.090	12.892
Lake Colorado City	0.043	0.090	12.675
Texoma Lake	0.042	0.160	12.493
E. V. Spence Reservoir	0.036	0.080	11.775
Palestine Lake	0.031	0.180	10.619
Kemp Lake	0.023	0.110	10.217
Possum Kingdom Reservoir	0.023	0.070	9.495
Twin Buttes Reservoir	0.029	0.250	8.708
Lake Buchanan	0.036	0.250	8.606
Lyndon B. Johnson Lake	0.042	0.420	8.100
Belton Reservoir	0.016	0.185	8.025
White River Reservoir	0.028	0.120	6.912
Fort Phantom Hill Lake	0.060	0.105	6.317
Sam Rayburn Reservoir	0.029	0.150	6.267
Eagle Mountain Lake	0.024	0.070	5.662
Travis Lake	0.018	0.250	5.595
Lavon Reservoir	0.063	0.180	5.400
Brownwood Lake	0.027	0.100	4.887
White River Reservoir	0.020	0.110	4.333
Stillhouse Hollow Reservoir	0.018	0.160	3.917
Lake Meredith	0.021	0.070	3.037
Canyon Lake	0.010	0.450	2.500
Amistad Lake	0.013	0.500	2.042

Source: U.S. Environmental Protection Agency National Eutrophication Survey.

V.C.2.a Procedures

In an attempt to determine the relative impact of the anticipated nitrogen and phosphorus mass loadings to Lake Granger with and without additional regional wastewater treatment facility(ies) located near Georgetown, a statistical analysis was performed on the EPA National Eutrophication Survey data for Texas lakes and the results used to predict the chlorophyll-a concentrations in Lake Granger. The following is an outline of that procedure:

- The EPA data was checked for potential anomalies or evidence of potential sampling errors. A three-dimensional plot of the chlorophyll-a, nitrogen, and phosphorus data was used to identify potential outliers and then the original data was rechecked to ascertain the reasonableness of the data.
- A multiple linear regression was performed on the EPA data for Texas lakes specifying the mean chlorophyll-a concentration as the dependent variable and total phosphorus and inorganic nitrogen concentrations as the independent variables.
- The developed regression equation was used to predict the chlorophyll-a concentration that may be anticipated in Lake Granger with and without a regional WWTP discharge.
- Whole lake water column concentrations for Lake Granger with and without a Georgetown regional WWTP were computed using the following equation:

$$\omega = [P] (z_{avg} \rho + v_s) \Rightarrow [P] = \omega / (z_{avg} \rho + v_s) \quad [V-15]$$

- The predicted nitrogen, phosphorus, and chlorophyll-a concentrations were then compared to the concentrations of other Texas impoundments.

V.C.2.b Computations

The three-dimensional plot identified two potentially anomalous data points (Figure V.22). In both cases, very high mass loadings of either nitrogen or phosphorus did not result in correspondingly high observed concentrations of chlorophyll-a. For these two points it was assumed that there was some mechanism other than nitrogen or phosphorus concentrations controlling the rate of algae growth (like light) and these points were removed from the sample population (Figure V.23).

The multiple linear regression revealed a large positive coefficient with respect to total phosphorus concentrations and a small negative coefficient for the inorganic nitrogen concentrations (Table V.22)

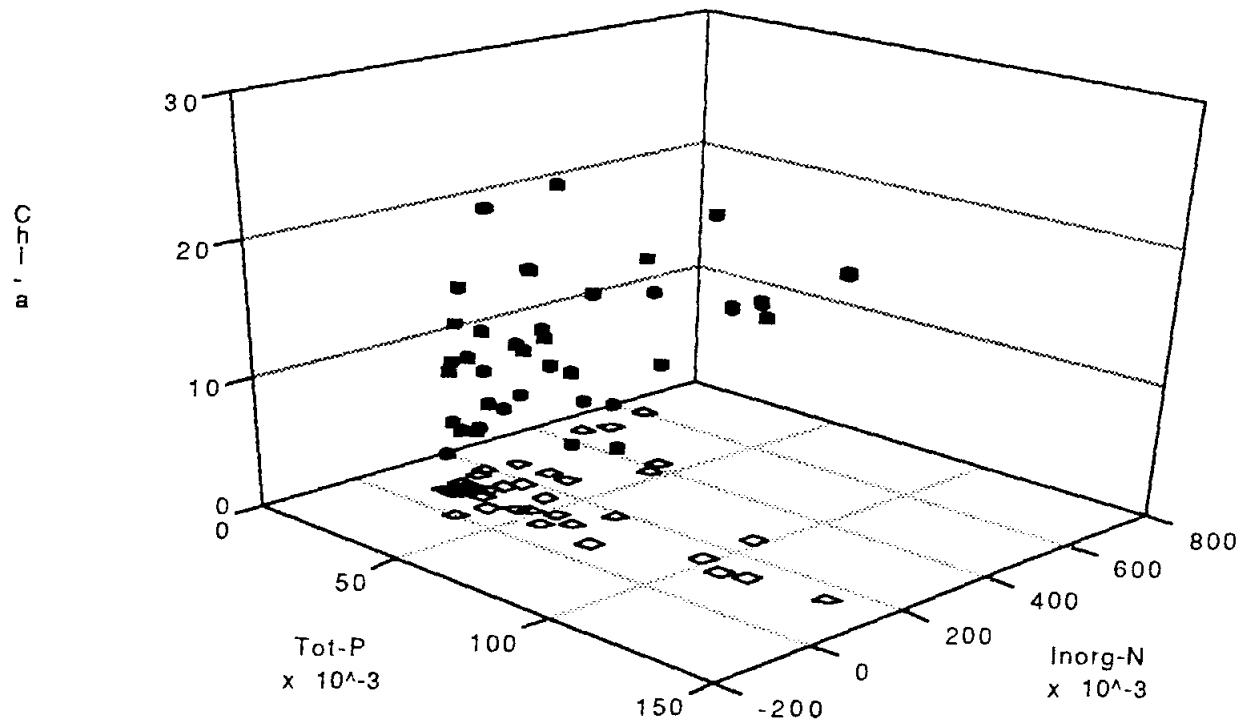

Figure V.22 Plot of Chlorophyll-a Concentration as a Function of Total Phosphorus and Total Inorganic Nitrogen Concentrations for Texas Lakes (All Data Included)

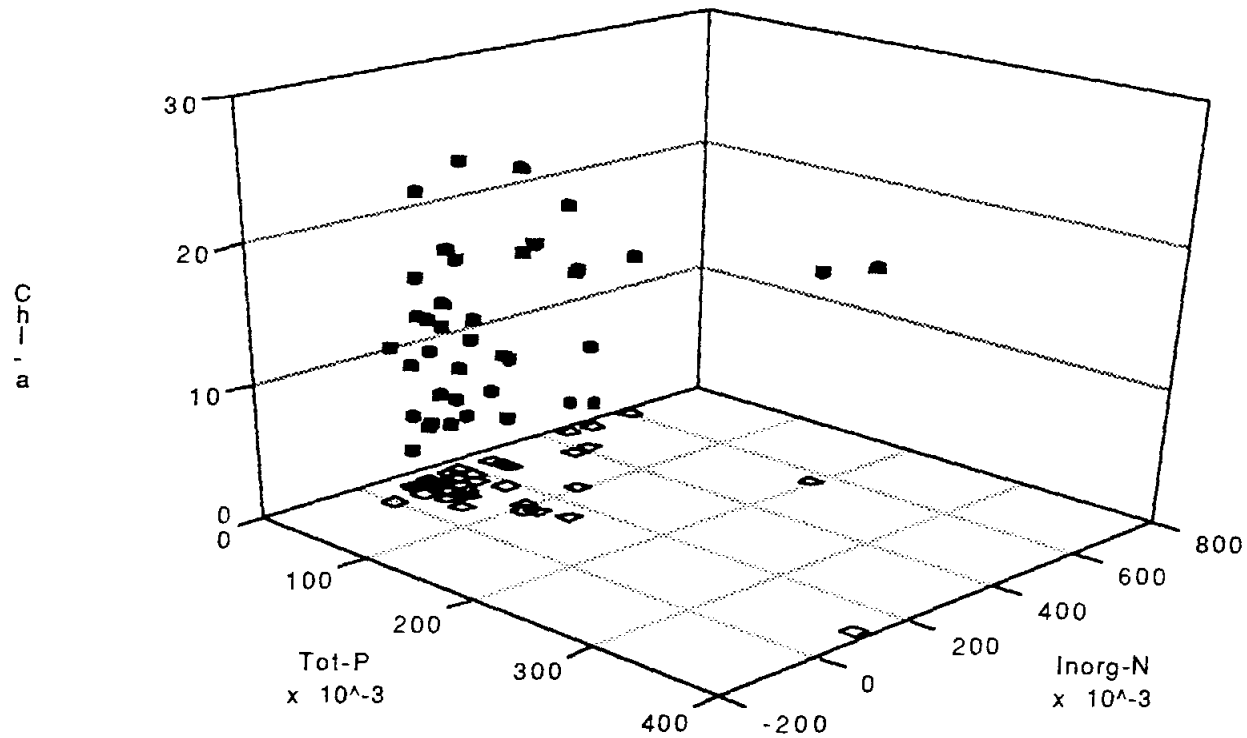

Figure V.23 Plot of Chlorophyll-a Concentration as a Function of Total Phosphorus and Total Inorganic Nitrogen Concentrations for Texas Lakes (Outliers Removed)

Table V.22

Multiple Linear Regression Results
(Chl-a = Dependent Variable; [N] and [P] = Independent Variables)

Variable	Coefficient
Constant	
Total Phosphorus	
Inorganic Nitrogen	-5.92
Correlation Coefficient (r^2) = 0.69	

Simple Linear Regression Results
(Chl-a = Dependent Variable; [P] = Independent Variable)

Variable	Coefficient
Constant	5.37
Total Phosphorus	143.47
Correlation Coefficient (r^2) = 0.68	

The coefficient of correlation (r^2) was 0.69, indicating only a reasonable fit of the data by the equation. Because a negative coefficient for the inorganic nitrogen concentration was considered highly unlikely and so individual regressions were performed for nitrogen and phosphorus (Figures V.24 and V.25). The slope of the nitrogen line was indeed negative and, therefore, was removed from consideration as a possible controlling nutrient in these systems. Also the r^2 for the phosphorus regression was 0.68 which was nearly as good as the multiple regression correlation. Therefore, the equation used for the anticipated chlorophyll-a concentration was:

$$[\text{Chl-a}] = 5.37 + 143.47 \cdot [\text{Tot-P}] \quad [\text{V-16}]$$

where [Chl-a] = Predicted chlorophyll-a concentration, mg/L,
 [Tot-P] = Total water column phosphorus concentration, mg/L,
 5.37 and 143.47 = Regression constants.

Without a Georgetown WWTP discharge the Lake Granger phosphorus and Chlorophyll-a concentrations would be:

$$[\text{P}]_{\text{w/o}} = (4,933 \text{ kg/yr}) / (17,805,585 \text{ m}^2) / \{ (5.91 \text{ m})(3.052 \text{ yr}) + 12.4 \text{ m/yr} \} \cdot 10^3 \text{ mg/L/kg/m}^3$$

$$= 0.0091 \text{ mg/L and}$$

$$[\text{Chl-a}]_{\text{w/o}} = 5.34 + 143.47 (0.0091) = 6.65 \text{ } \mu\text{g/L}$$

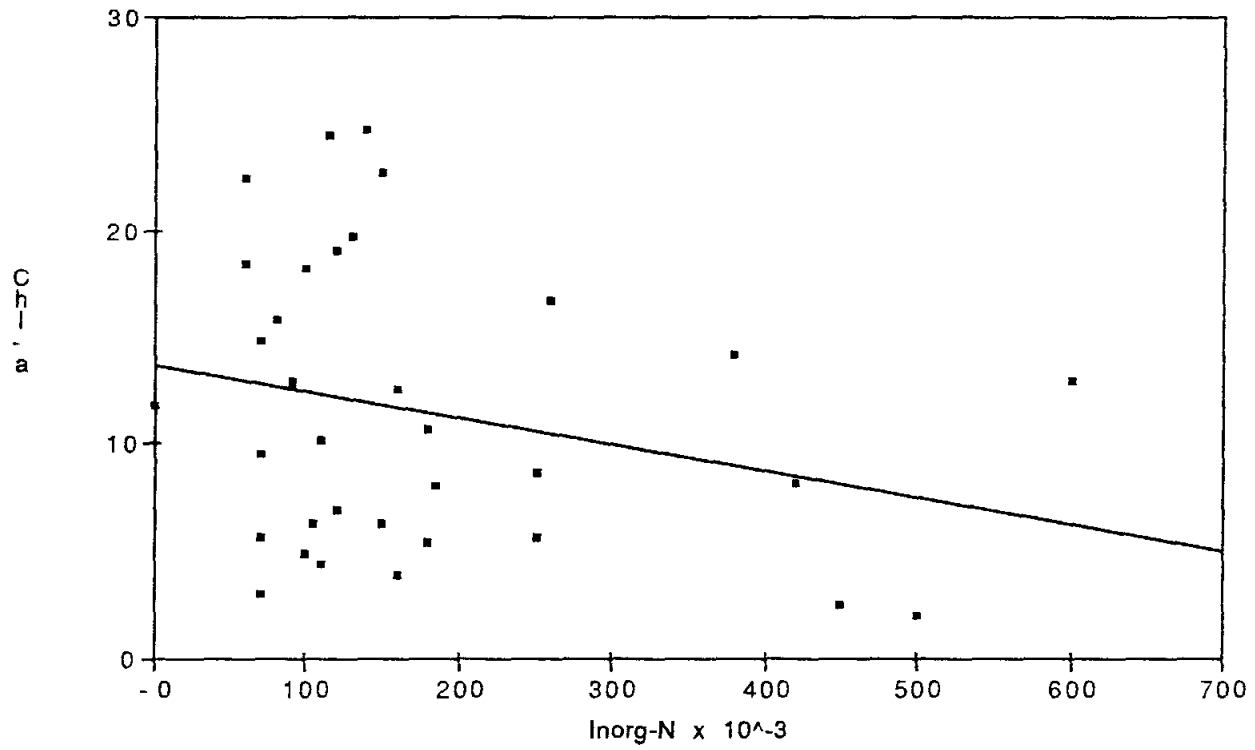

Figure V.24 Plot of Chlorophyll-a Concentration as a Function of Total Inorganic Nitrogen Concentrations for Texas Lakes

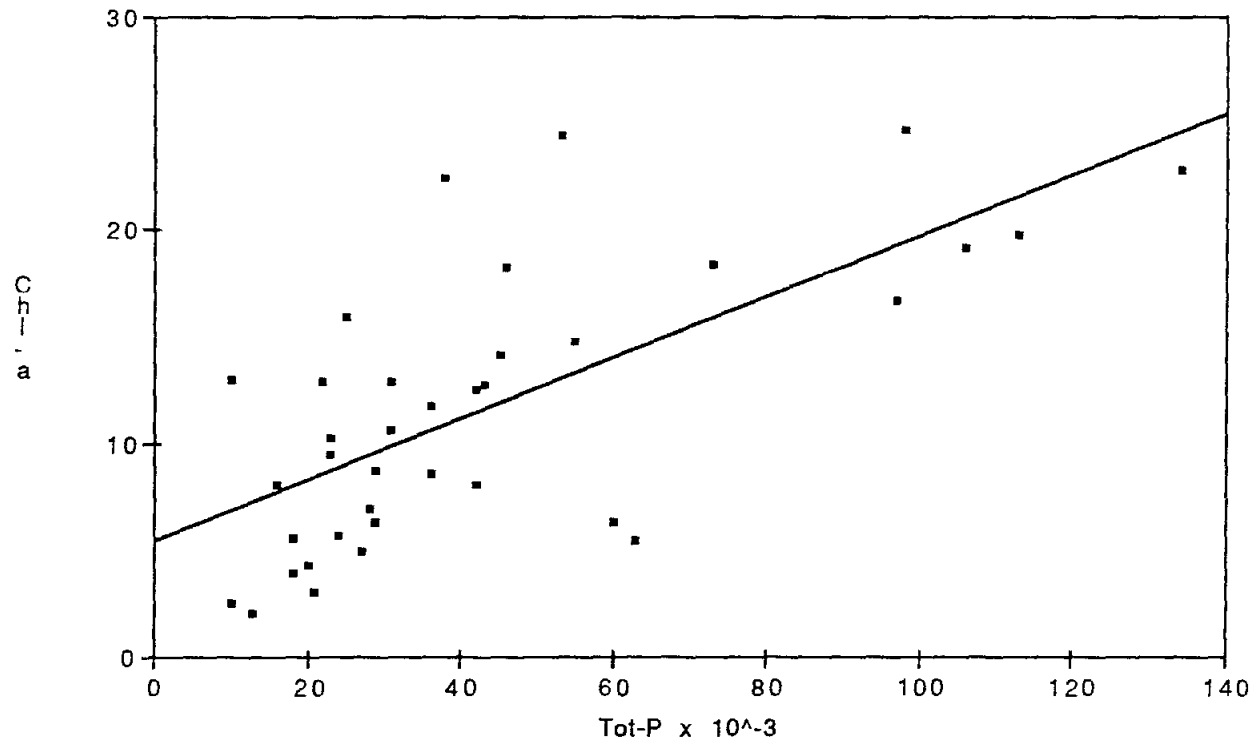

Figure V.25 Plot of Chlorophyll-a Concentration as a Function of Total Phosphorus for Texas Lakes

With the Existing Georgetown WWTP discharge the Lake Granger phosphorus and Chlorophyll-a concentrations would be:

$$\begin{aligned} [P]_w &= \{(4,933 + 18,900 \text{ kg/yr}) / (17,805,585 \text{ m}^2)\} / \{(5.91 \text{ m})(3.081 \text{ yr}) + 12.4 \text{ m/yr}\} \cdot \\ &\quad 10^3 \text{ mg/L/kg/m}^3 \\ &= 0.0437 \text{ mg/L and} \end{aligned}$$

$$[\text{Chl-a}]_w = 5.34 + 143.47 (0.0437) = 11.61 \text{ } \mu\text{g/L}$$

With a 2030 Georgetown Regional System discharge the Lake Granger phosphorus and Chlorophyll-a concentrations would be:

$$\begin{aligned} [P]_w &= \{(4,933 + 77,369 \text{ kg/yr}) / (17,805,585 \text{ m}^2)\} / \{(5.91 \text{ m})(3.170 \text{ yr}) + 12.4 \text{ m/yr}\} \cdot \\ &\quad 10^3 \text{ mg/L/kg/m}^3 \\ &= 0.148 \text{ mg/L and} \end{aligned}$$

$$[\text{Chl-a}]_w = 5.34 + 143.47 (0.148) = 26.4 \text{ } \mu\text{g/L}$$

V.C.2.c Results

- EPA National Eutrophication Survey data for Texas lakes indicate that Lake Granger is most likely phosphorus limited, i.e., phosphorus is the limiting nutrient to the growth rate of algae within the reservoir. Given this fact, phosphorus becomes the nutrient of control from point and nonpoint sources.
- Lake Granger is an extremely short detention-time reservoir. The average hydraulic detention time, τ , is approximately four months. Conversely stated, Lake Granger passes through approximately three volumes of the reservoir per year. Short retention time reservoirs tend to be relatively forgiving with respect to high nutrient loading. Because the contact time between the water with high nutrient concentrations and the algae population is fairly short, the algae do not have the opportunity to fully utilize the available nutrient for biomass production.
- Lake Granger receives approximately 248,998,795 m³/yr of storm water runoff and wastewater discharge flows. At the City of Georgetown's present rate of discharge of 1.71 MGD (1987), the City wastewater discharge accounts for very little (approximately 1 percent) of the total annual average inflow to Lake Granger. However, the City contributes approximately 18,900 kg/yr of phosphorus and 16,868 kg/yr of inorganic nitrogen to Lake Granger, ranking it as the highest single source of nutrient loadings to the lake.

- Non point sources contribute approx 4,933 kg/yr of orthophosphate and approximately 16,861 kg/yr of inorganic nitrogen to Lake Granger.
- With the City of Georgetown's treatment plant removed from the system, nonpoint source loadings to Lake Granger would result in a classification of the lake as oligotrophic under the classification system developed by Vollenweider et al. Under existing conditions, assuming the City of Georgetown discharges at 1.71 MGD, the combined point and nonpoint source loading to Lake Granger result in a probable classification as mesotrophic. Under 2030 development conditions, assuming a regional system comprised of one or more plants treating a total of 7 MGD, the total loading from point and nonpoint sources of nitrogen and phosphorus would be approximately 127,081 kg/yr and 82,302 kg/yr respectively. This would result in the classification of Lake Granger as highly eutrophic under the Vollenweider et al classification scheme.

VI ENVIRONMENTAL CONSIDERATIONS

VI.A Introduction

In considering the expansion of wastewater treatment facilities in the Georgetown area, a variety of environmental issues arise. As mentioned earlier, the area straddles the Balcones Escarpment, with the preferred growth areas overlying the Edwards Aquifer recharge zone. Thus, in siting such facilities, geological considerations may be of great importance, in particular for determining the eastern boundary of the recharge zone.

Because the area is at the junction of two distinct biological ecosystems, it has the potential to have a great variety of species, some of which may not occur in other areas of the state. An overall survey of the area was undertaken in order to determine whether it contained any threatened or endangered species or any unique habitats. A similar overview of cultural resources is also presented, because previous excavations, largely in association with reservoir construction, have revealed a diversity of artifacts.

This section consists of three reports prepared under subcontract. The geological data was analyzed by Charles Woodruff, Consulting Geologist, Austin, Texas; the biological data was collected by Paul Price and Associates, Austin, Texas; and the cultural resources information was compiled by David Brown and Marybeth Tomka, Horizon Environmental Services, Inc., Austin, Texas.

VI.B Geology and Groundwater Hydrology of the Georgetown Area,

VI.B.1 Introduction

VI.B.1.a General Setting

The City of Georgetown lies astride the Balcones Fault Zone. This fault zone comprises a series of high-angle normal faults that generally trend northeast-southwest and that have overall displacement down toward the Gulf of Mexico. Owing to the geometry of faulting, Lower Cretaceous limestones are exposed west of the main fault line; Upper Cretaceous claystones, chinks, and marls are exposed to the east. However, in the Georgetown area, detailed bedrock conditions are commonly obscured by extensive veneers of alluvium that occur at various topographic elevations on the east side of the fault zone.

Bedrock changes across the fault zone have had profound impacts on terrain, soil, vegetation and various hydrologic attributes. West of the main fault line, streams are commonly incised into the limestone strata and form ruggedly dissected landscapes. These incised streams furnish recharging waters into porous strata. East of the fault line, streams have meandered across wide valleys cut in the soft substrates. Bedrock is generally less porous and permeable, hence, recharge is not a major process there. Besides

the effects on surface water and groundwater supplies, the fault zone has imposed major controls on weather patterns. The Balcones Escarpment is the first extensive topographic break inland from the Gulf of Mexico, and thus it has a destabilizing influence on water-laden air masses. The Escarpment region is the locus of largest flood-producing storms in the conterminous United States.

Various hydrologic issues pose potential problems with land use in the Georgetown area. The Edwards Aquifer historically has been the main source of potable water for Georgetown and other communities along the fault zone. Most aquifer recharge occurs west of the main fault line, but the upper member of the aquifer (the Georgetown Limestone) occurs at low topographic levels to the east. Facilities must also be planned with peak storms in mind. The Thrall Flood of 1921 resulted from more than 38 inches of rain falling within 24 hours--one of the record rainfall events ever recorded in the country.

VI.B.1.b Purpose

Given the geologic, topographic and hydrologic setting of the Georgetown area, wastewater treatment and disposal must be planned with the various hydrologic resources and processes in mind. Specific attention must be given the Edwards Aquifer. Hence, a geologic survey has been included as part of the engineering/water-quality planning and design studies.

The objectives of the geologic survey are to present a geologic map and to delineate the recharge zone of the aquifer. Special attention is also given existing water wells, as they indicate where potable water is produced from the aquifer. Moreover, data on depth, water chemistry and method of well completion provide information on aquifer characteristics and on the likelihood of vertical groundwater movement in areas beyond those mapped as being subject to recharge. These data allow planners and designers of the proposed wastewater treatment facilities to mitigate possible impacts.

VI.B.1.c Methods

This survey is based mainly on compilation of two types of data: geologic mapping and the locations and tabular information on water wells. Besides the compilation of existing data, field surveys were performed to verify the gross accuracy of the geologic and hydrologic information.

The geologic map is derived from an unpublished report by the Bureau of Economic Geology at the University of Texas at Austin (mapping by E. W. Collins, in Kreitler and others, 1988). It shows the extent of outcropping rocks and sediments, and the inferred presence of faults.

Ground water data were obtained from a survey of the "Located Well File" from Central Records of the Texas Water Commission. This data file contains information on well completion, strata penetrated, producing horizon, as well as tabular information on property owner, driller, and use to which the water is put.

In addition, for some wells there are data on water quality and well yield. The wells in this file represent a subset of actual wells occurring in the area. Many recently drilled wells have not been included in the State files; likewise, early wells may have escaped the inventory altogether.

The wells inventoried are limited to those listed in the State data files as having produced water from the Edwards Aquifer. These wells are identified by an official State Well Number (SWN), the last three digits of which are shown with each well's spotted location. The complete SWN is seven digits long; the first four digits corresponding to 1-degree quadrangle (two first digits); the next two digits correspond to the 7.5-minute quadrangle within the specified 1-degree grid.

VI.B.2 Findings

VI.B.2.a Geologic Setting

A geologic map of the Georgetown area clearly shows the effect of the Balcones Fault Zone. Faults with displacements of several tens of feet trend northeast-southwest. Displacement is down-to-the-east. Hence, progressively younger strata are exposed in a west to east traverse. The main line of fault displacement roughly coincides with Interstate Highway 35 (IH-35). West of the main fault line, bedrock is Edwards Limestone and older, underlying units. East of the main fault, progressively younger strata are exposed: Georgetown Formation, Del Rio Clay, Buda Limestone, Eagle Ford Formation and Austin Chalk (see Table VI.1). Besides the main faults, there are numerous other faults of small displacement that generally parallel the trends of the major faults (Collins, 1987). In addition, bedrock is locally cut by numerous joints (fractures without appreciable displacement), which as pointed out by Collins (1987), are most common in areas close to major faults.

The geologic setting determines local hydrologic processes. The recharge zone of the aquifer is defined as including the outcropping extent of the Edwards Limestone plus the Comanche Peak Formation below and the Georgetown Formation above. Of the three members, the Edwards Limestone is, by far, the main water-bearing unit. It is the thickest (up to 300 ft thick in the area surveyed), and the only one of the three that exhibits major karst features (caves and sinkholes), which provide conduits for rapid transmission of groundwater.

The Georgetown formation is in hydrologic communication with the underlying Edwards. However, the Georgetown is not a major transmitter of groundwater. Local recharge into, or discharge from, the aquifer may occur, but the most likely loci for recharge and discharge are along faults or associated fractures. Georgetown Springs issue forth along the San Gabriel River from the Georgetown Limestone (beneath a veneer of alluvium). This discharge, however, is probably controlled by fracture porosity associated with a major fault nearby (Collins, 1987).

Table VI.1
General Stratigraphic Section - Georgetown Area

<u>Formation/Group</u>	<u>General Description</u>
<u>Quaternary Age--Surface Deposits</u>	
Qu--Surface Deposits Undivided	Sand and gravel, dominantly limestone; caliche cement common; occurs at various topographic levels.
Qt--Terrace Deposits	Sand and gravel, dominantly limestone fragments; occupies flat terrain above present floodplains.
Qal--Alluvium	Modern valley deposits--channel and floodplain; coarse gravel in channels; fine-grained sediment in floodplains.
<u>Cretaceous Age--Bedrock</u>	
Kau--Austin Chalk	Chalk and soft limestone, thin to thick bedded; not an important water-bearing unit; porous zones localized along fractures.
Kef--Eagle Ford Formation	Clay-shale, dark gray, high montmorillonite; local lenses of limestone; major aquitard.
Kbu--Buda Limestone	Limestone, upper part resistant; lower part easily eroded; not an aquifer.
Kdr--Del Rio Clay	Claystone; high shrink swell; low permeability; forms the seal above the Edwards Aquifer.
Kgt--Georgetown Formation	Limestone, nodular, locally marly and thin-bedded; upper member of Edwards Aquifer.
Ked--Edwards Limestone	Limestone, hard, pure, variable bedding; solution features common; major water bearing formation.
Kc--Comanche Peak Formation	Limestone; nodular, marly; limited water-bearing unit; basal member of Edwards Aquifer.

On the basis of the areal extent of geologic units, there have been various constructs of the eastern edge of the recharge zone in the Georgetown area. The Bureau of Economic Geology (BEG) delineated the boundary of the recharge zone on the basis of their geologic mapping in the area. The BEG boundary coincides with the eastern extent of the Georgetown Formation (Kriegtler and others, 1988). The Texas Water Commission (TWC) mapped another line that does not coincide with the outcrop of any recharging

unit. The TWC line was drawn before the BEG maps were produced, and it represents a more conservative interpretation on where recharge might occur (Figure VI.1).

Both constructs provide likely margins of safety in terms of protecting the aquifer. This is true because of the generally low water-transmitting properties of the Georgetown Formation. In matters of effluent discharge, such margins of safety are important. And, given the possibility of faults providing avenues for upward or downward movement of groundwater, the TWC boundary is preferred because of its greater margin of safety. The TWC boundary coincides with a fault that crosses the San Gabriel River near its confluence with Berry Creek. This fault, according to the BEG map, does not represent a major transposition of bedrock units; Del Rio Clay occurs on both sides of the fault plane. Hence, the fault is an unlikely avenue for groundwater movement.

Subsurface data also support the conclusion that hydrologic communication between surface waters and groundwater is unlikely at or beyond the TWC aquifer boundary. Groundwater data compiled from TWC files contain some information on rock properties at depth. This information includes geophysical logs and drillers' records of rocks penetrated (although there are no geophysical logs in this area). A few wells in the vicinity of the confluence of Berry Creek and San Gabriel River (downstream from the TWC aquifer boundary) have drillers' reports that show the contact between Del Rio Clay and Georgetown Formation (the top of the aquifer) at depths of several tens of feet below river level. One log, which is likely in error, shows a depth to the top of the aquifer of more than 200 feet. These subsurface geologic interpretations, although sparse, support the conclusion that there is little likelihood for infiltration beyond the aquifer boundary assigned by TWC.

VI.B.2.b Groundwater

A survey of the Located Well File of the TWC resulted in the plotting of 65 wells that produce (or historically produced) from the Edwards aquifer in the Georgetown vicinity (Figure VI.2). These wells are important sources of information on the aquifer, although the data are not consistent in quality or quantity from well to well. Available information includes depth drilled, total dissolved solids (in milligrams/liter), wells in which open-hole completion has been employed, wells used for public water supply, and the drillers' pick for the top of the aquifer (Del Rio/Buda contact).

The groundwater data indicate the widespread use of groundwater from the Edwards Aquifer across the prairie terrain east of Georgetown. Data on water quality suggest that the eastern limit of potable water in the aquifer (the "bad-water lines") may lie east (downstream) of the confluence of Mankin's Branch and the San Gabriel River. The nearest well downstream from that confluence displays a total dissolved solids value of 1800 mg/l. The increase in water salinity to a value greater than 1000 mg/l marks the recom-

GEORGETOWN TOWN TERRITORIAL
WASTEWATER PLANNING
STUDY

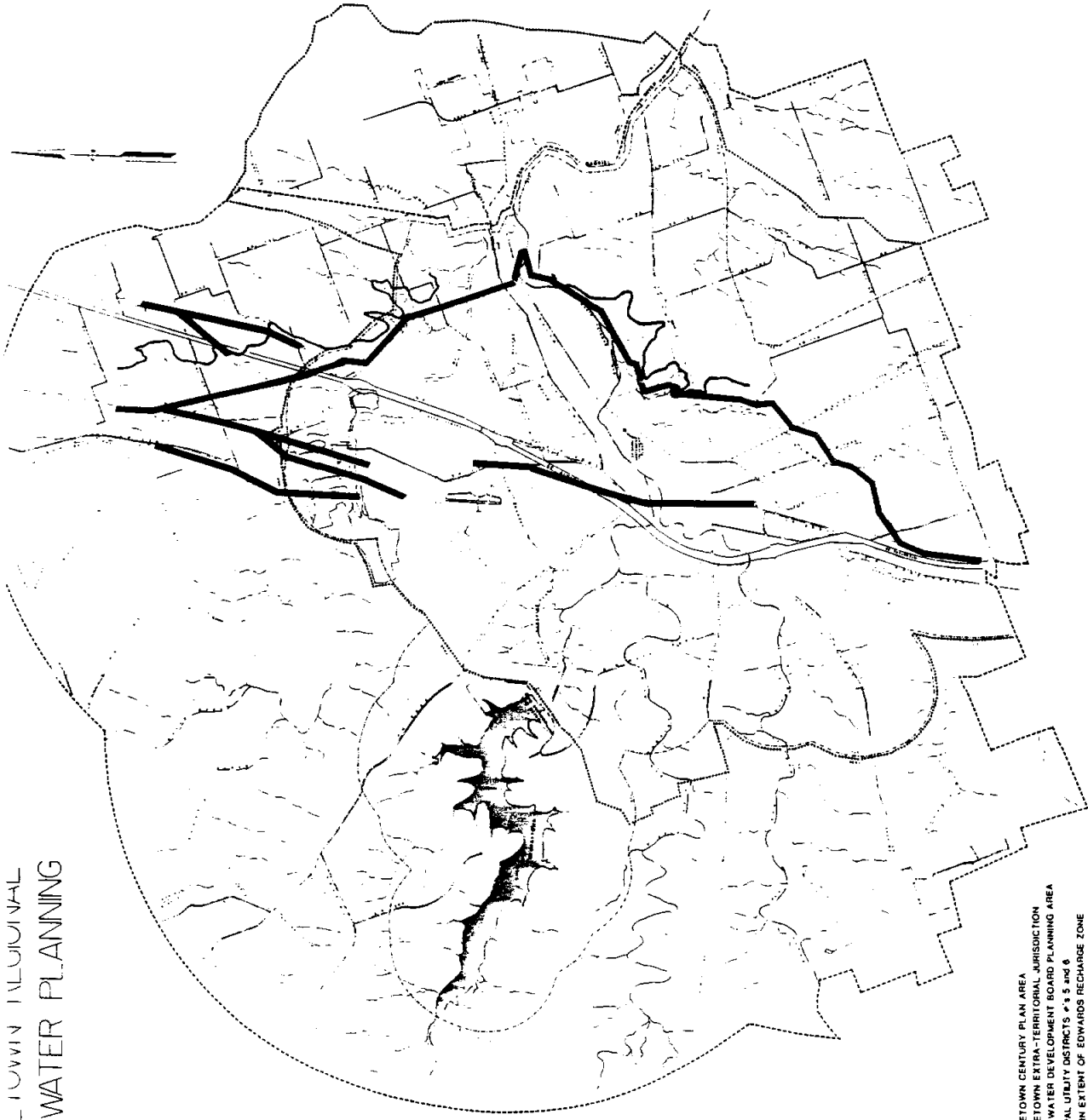

- LEGEND**
- GEORGETOWN CENTURY PLAN AREA
 - GEORGETOWN EXTRA-TERRITORIAL JURISDICTION
 - TEXAS WATER DEVELOPMENT BOARD PLANNING AREA
 - MUNICIPAL UTILITY DISTRICTS # 5 and 6
 - EASTERN EXTENT OF EDWARDS RECHARGE ZONE
 - ▬ NORMAL FAULT
 - ▬▬▬ EASTERN EXTENT OF RECHARGE ZONE (TWC)

WWTW
WALLACE, WINKLER & ROSE, INC.
ENGINEERS - PLANNERS - SURVEYORS
1925 N. TEXAS

GEORGETOWN REGIONAL
WASTEWATER PLANNING
STUDY

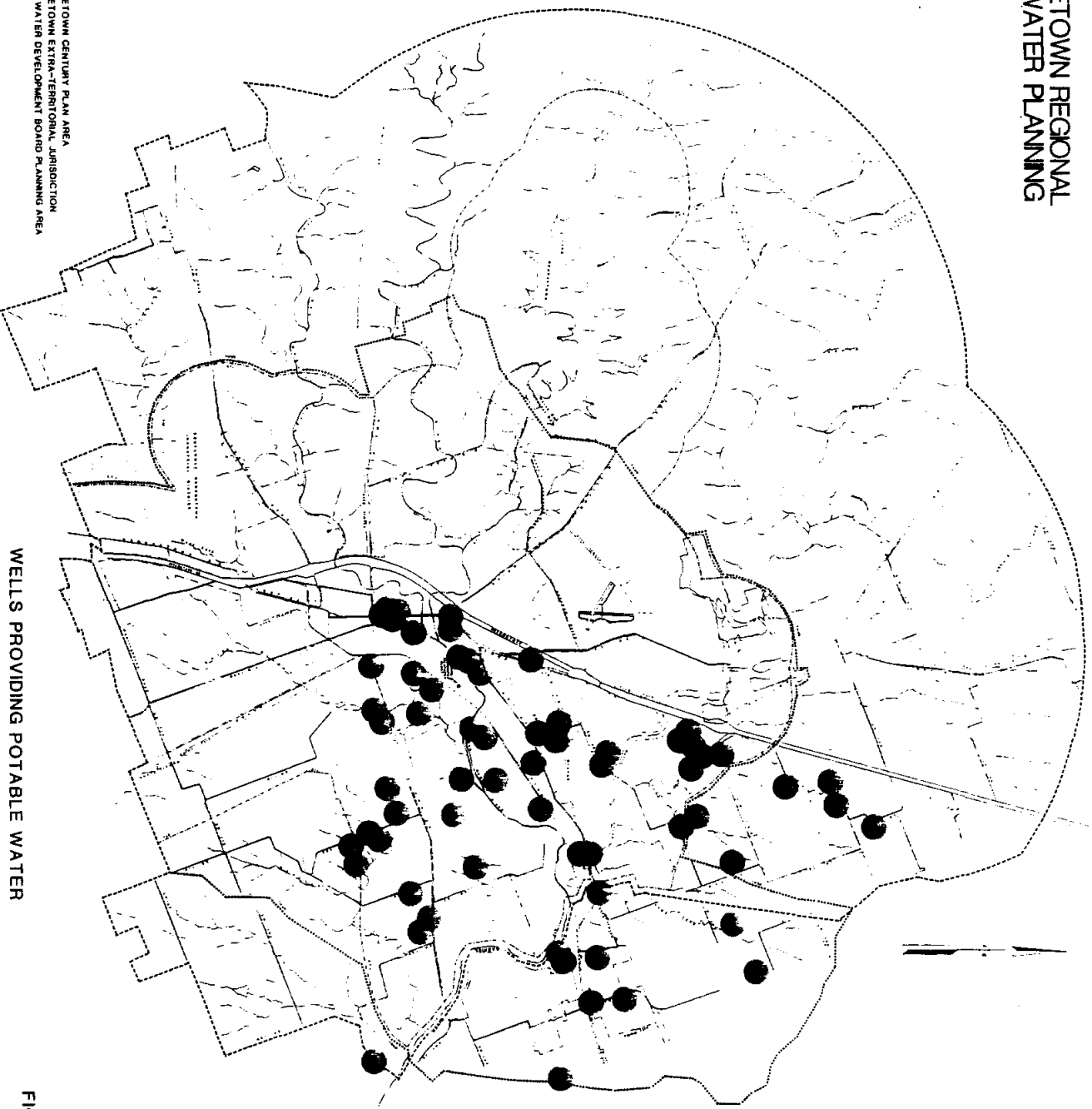

WELLS PROVIDING POTABLE WATER

FIGURE VI.2

WWR
WALLACE WINKLER & RICE, INC.
ENGINEERS • PLANNERS • ARCHITECTS
DALLAS • HOUSTON • SAN ANTONIO

mended limit of potability. Hence, the "bad-water line" marks the effective eastern limit of the aquifer as a reservoir for human uses, although the well producing water with a total dissolved solids level of 1800 mg/l is denoted as a "public-supply" well in TWC records. It is not apparent what public entity uses this water, as the well is situated far from any apparent development.

As already mentioned, the groundwater data show drillers' interpretations of the strata that delineate the upper limits of the aquifer. Besides these interpretations, well depth suggests actual depth of the water-bearing strata. In the vicinity of the Berry Creek/San Gabriel River confluence, the shallowest well is 72 ft deep. That depth probably is slightly greater than the depth to the Edwards aquifer. Notably, the Del Rio Clay is approximately 75 ft thick in this area, and that well (SWN 58-20-411) is situated in an area of Del Rio Clay veneered by alluvium.

Several wells (58-20-409, 410, and 411) are apparently completed as "open-hole" wells. This is unlikely, because they penetrate Del Rio Clay near the surface, and for that reason they would be subject to long-term failure due to spalling and plastic creep of the unstable claystone into the well bore. At any rate, special attention should be paid to any "open-hole" wells, should they actually exist, because such wells may provide conduits for transmission of surface waters into the subsurface. Such transfer is unlikely to result in pollution of the groundwater reservoir to any great extent, but it may result in contamination of the immediate environs of the culprit well. Such contamination is common in areas where barnyards, cesspools or septic tanks are situated near open-bore wells.

VI.C Conclusions

Geological mapping and information from water-well files suggest the limits to the recharge zone of the Edwards Aquifer. In the Georgetown area, and especially along San Gabriel River, a conservative interpretation of the eastern edge of the recharge zone is near the confluence of Berry Creek with the San Gabriel. This interpretation is supported by surface mapping (downstream extent of exposed Georgetown Limestone) and by subsurface mapping (drillers' logs indicating depth to the aquifer of several scores of feet). Cautionary information is posed by well-completion and water-quality data. Several open-hole wells may occur near the Berry Creek-San Gabriel River juncture, and these wells could act as conduits for interchange of waters between the surface and the subsurface. Water-chemistry data indicate that the eastern edge of the potable aquifer may lie somewhat west of the confluence of Mankin's Branch with the San Gabriel River.

VI.C BIOLOGICAL RESOURCES OF THE SAN GABRIEL RIVER BETWEEN GEORGETOWN AND LAKE GRANGER

VI.C.1 Introduction

This survey is intended to provide an overview of the biological resources of the San Gabriel River from the existing wastewater outfall in Georgetown to Lake Granger. It is based on available literature and observations made during a field survey conducted July 14th, 1988.

The river was observed at five locations:

- Station 1: the 2550 foot reach from the existing Georgetown outfall below the city park to the low water dam below the islands;
- Station 2: from the State Highway (SH) 29 bridge extending about 1200 feet downstream.
- Station 3: the vicinity of the FM 1660 bridge;
- Station 4: the vicinity of the unmarked county road bridge upstream of SH95; and
- Station 5: near Registration Box 7 of the Granger Wildlife Management Unit on County Road 347.

These locations are the only public access points within this river reach, and Station 5 is part of Lake Granger.

VI.C.2 Regional Setting

The San Gabriel River is part of the Little River system, a major tributary of the Brazos River. The San Gabriel is a fourth order stream with its headwaters rising in the Edwards Plateau Region of eastern Burnet County and its confluence with the Little River in central Milam County. At Georgetown, where the North and South forks of the San Gabriel join, the river drains an area of 399 square miles, while the drainage area at the SH 95 crossing just upstream of Granger Lane is 602 square miles (USGS, 1965). In spite of a 200 square miles gain in drainage area, there appears to be little or no gain in discharge in this approximately 20 mile reach (USGS, 1988). Since Lake Georgetown was completed on the North San Gabriel upstream of the City of Georgetown in 1980, the amount and timing of streamflow in this reach has been altered by reservoir operation.

In the reach from Georgetown to Lake Granger, the San Gabriel River traverses the transition between the Edwards Plateau and Blackland Prairies Vegetation Regions (Gould, 1969). The eastern boundary of the former region, which generally corresponds to the Balconian Biotic Province (Blair, 1950), is marked by

the Balcones Escarpment. The San Gabriel crosses the escarpment between the City of Georgetown and the SH 29 bridge.

Downstream of SH 95 the river is contained within the Granger Wildlife Management Unit. This area is maintained by Texas Parks and Wildlife Department and owned by the U.S. Army Corps of Engineers as part of the Lake Granger lands. Riverine (flowing water) habitat gives way to Lake Granger backwater between SH 95 and Station 5.

VI.C.3 Habitats

The river in this reach is generally bordered by a riparian woodland of varying width, while the surrounding countryside is mostly open land cleared for agricultural activities. While rangeland constitutes the dominant land use in the vicinity of Georgetown and in the Balconian uplands to the west, dry cropland predominates in eastern Williamson County (TDWR, 1978). Riparian woodland, consisting primarily of relatively recent regrowth and of pecan bottoms, tends to become wider downstream as mesic conditions extend farther from the river in the deeper soils and lesser relief of the Blackland Prairie.

Streambanks at the three upper stations are generally low (up to 10 feet) but steep to vertical. At Stations 2 and 3 they typically consist of massive, low limestone bluffs. A notable exception is the 30 foot sandy bluff on the left (north) side of the river below the city park in Georgetown. Vegetation is restricted to riparian strips and does not shade much of the channel.

In the upper part of the study reach, the channel of the San Gabriel River is typically 130 to 140 feet in width, with a solid limestone slab substrate occasionally covered by sheets or bars of gravel (Figure VI.3). Large, vegetated gravel bars occupy a 600-1000 foot reach of the channel below the existing wastewater outfall at Station 1, creating several cobble-gravel riffles where the channel is constricted. However, riffle habitat in the rest of this reach appears to be quite restricted in extent, except for the shallow sheets of water flowing over solid limestone bottoms.

Water depths are generally shallow at the upper stations, not more than about two feet at Stations 1 and 2. Station 3 exhibited deeper pools (>3 feet) up and downstream of the shallow (2-5 inch) slab bottom present at the bridge crossing. Deeply eroded grooves and potholes in the slabs provide some cover for forage fish, but these stations were typically quite open, with little aquatic vegetation or structural diversity except along the banks. Aquatic vegetation was most abundant at Station 2 when this survey was conducted. Channel configurations and substrates are illustrated in Figure VI.3, drawn from measured transects at each station.

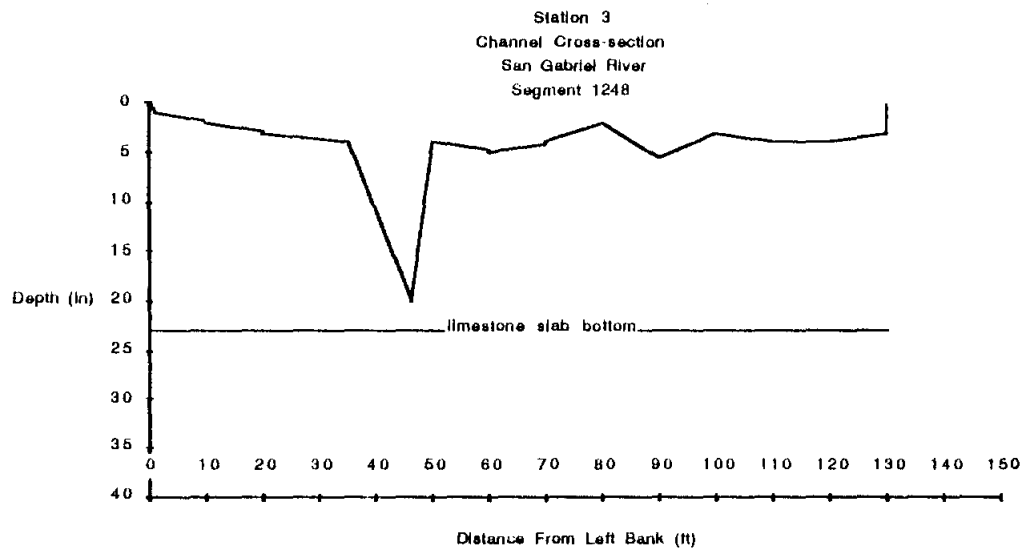
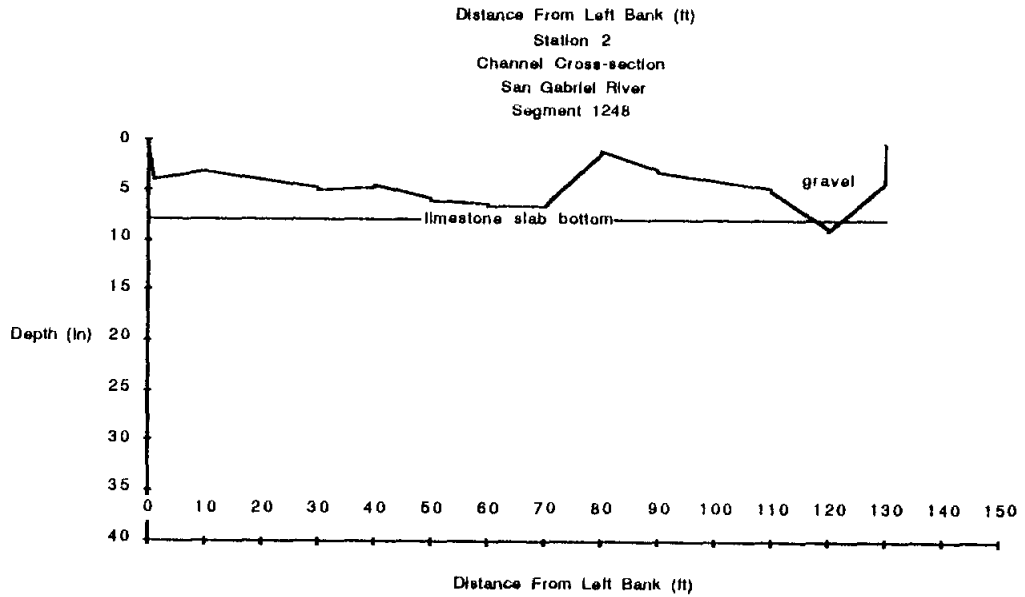
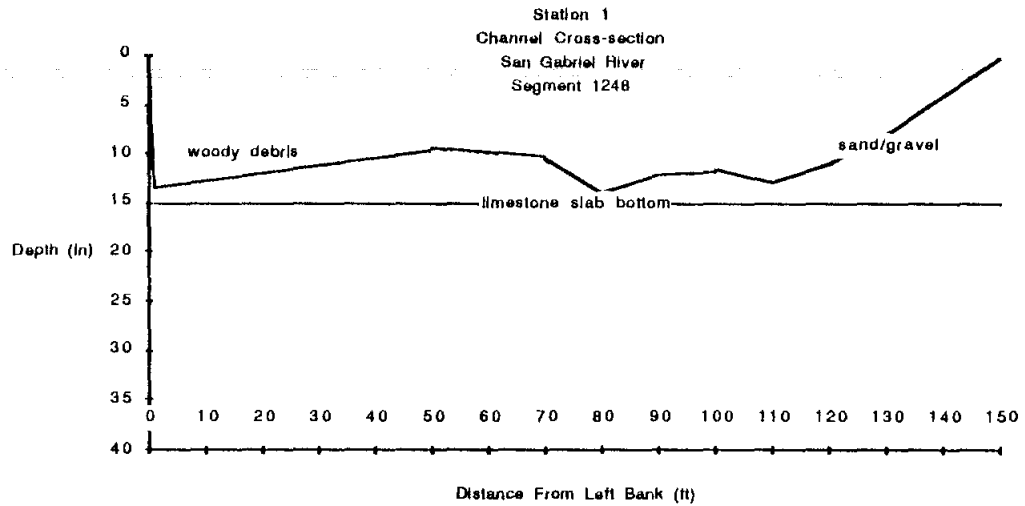
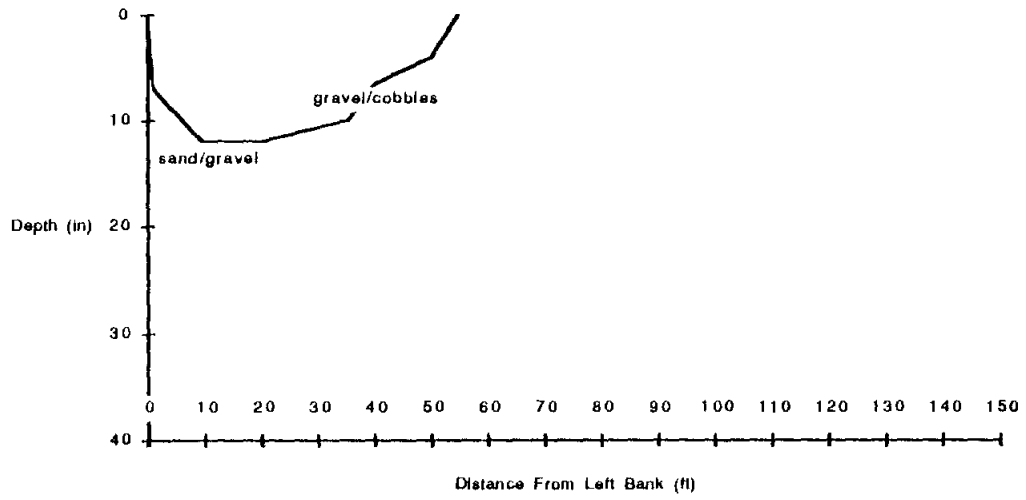

Figure VI.3 San Gabriel River Cross-sections

Station 4 - Rifle
 Channel Cross-section
 San Gabriel River
 Segment 1248



Station 4 - Pool
 Channel Cross-section
 San Gabriel River
 Segment 1248

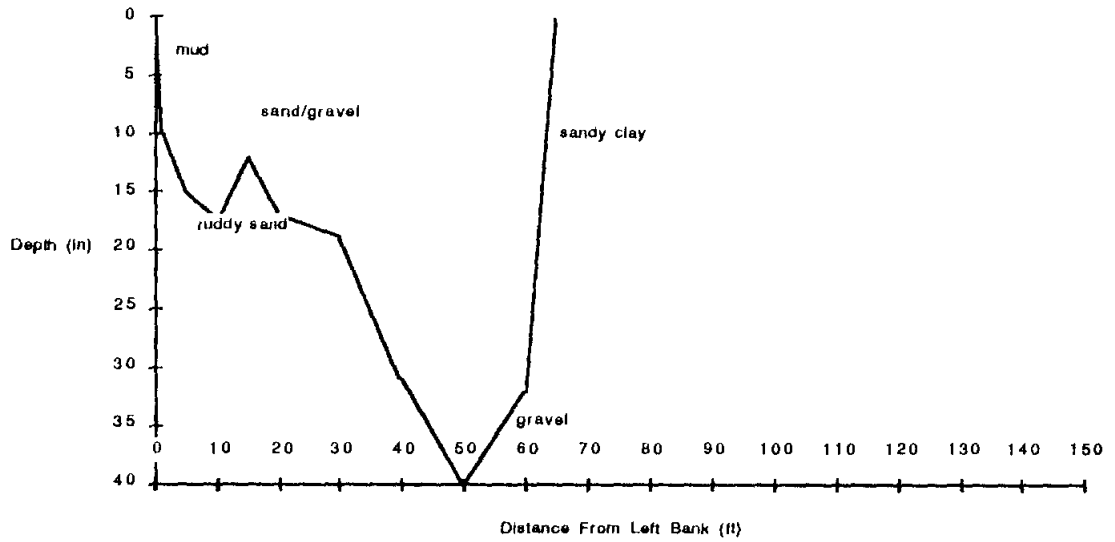

Figure VI.3 (Continued) San Gabriel River Cross-sections

At Station 4 the channel is much narrower (45-65 feet), deeper (to 41 inches) and is contained within steep (30-45°), sandy banks about 20 feet high. Because of the narrow channel and steep banks, the stream is almost completely shaded here. Substrates are unconsolidated at Station 4, ranging from muddy sand to gravel and cobbles. In this reach, gravel riffles alternate with deeper pools that are mostly floored with sand and gravel but also exhibit patches of muddy sand and accumulations of leaves and woody debris. Such areas are important as invertebrate and forage fish habitat. Although aquatic vegetation is only sparsely present at the upper stations where suitable substrates occur, shading and deeper water result in its complete absence at Station 4.

At Station 4, the San Gabriel River has changed character markedly from that of its upper reaches. It is now a typically eastern stream with a relatively narrow and deep channel sharply incised into its floodplain, and banks and bed of unconsolidated clays, sands and gravel. Dense shading and little plant life result in primarily detrital food chains.

At Station 5, the channel was completely inundated by backwater from Lake Granger and was extremely turbid on July 14th, 1988. Numerous stumps and standing dead trees were present in the water.

VI.C.4 Important Species

The more common tree species observed along the study reach include pecan (*Carya illinoensis*), cedar elm (*Ulmus crassifolia*), American elm (*U. americana*), Texas ash (*Fraxinus texensis*), hackberries (*Celtis spp.*) willow (*Salix spp.*), sycamore (*Platanus occidentalis*), bur oak (*Quercus macrocarpa*), osage orange (*Maclura pomifera*), chinaberry (*Meila azedarach*) and an occasional bald cypress (*Taxodium distichum*). Shrub and vine species include possumhaw (*Ilex decidua*), button bush (*Cephalanthus occidentalis*), buckthorn (*Rhamnus caroliniana*), dewberry (*Rubus spp.*), mustang grape (*Vitis mustangensis*), green briar (*Smilax rotundifolia*), and poison ivy (*Rhus toxicodendron*).

Adjacent to the water, streambank and marginal aquatic vegetation includes large grasses such as switchgrass (*Panicum virgatum*) and johnsongrass (*Sorghum halapense*), giant ragweed (*Ambrosia trifida*), rattlebush (*Sesbania drummondii*), cocklebur (*Xanthium strumarium*), and smartweed (*Polygonum spp.*). Sedges (*Carex spp.*), parrotfeather (*Myriophyllum brasiliense*), watercress (*Nasturtium officinale*), and maretail (*Hippuris vulgaris*) were collected at Station 2. Submersed and marginal aquatic vegetation was less abundant at Stations 1 and 3, apparently due to a lack of suitable substrate, and absent at Station 4.

Large clumps of dark, filamentous algae were observed at Stations 2 and 3, where they occurred both attached and as floating masses. The clumps consisted mostly of *Oscillatoria princeps*, a bluegreen alga commonly occurring in waters significantly enriched by organic and nutrient input. Other algal taxa present

included *Scenedesmus dimorphus*, *S. quadricauda*, *Dactylococcopsis fascicularis*, *Chlorella sp.*, *Pedias-trum sp.*, and *Coelastrum sp.*, all taxa known to be tolerant of organic pollution (Palmer, 1968).

The cases and nets of caddisflies (Trichoptera) of the family Hydropsychidae were present in very large numbers on the rock slabs flooring Stations 2 and 3. Station 3, in addition, harbored large populations of another caddisfly, *Helicopsyche sp.* These insects are widely distributed in well illuminated, rocky bot-tomed streams throughout central and west Texas, where they are typical herbivores feeding directly on suspended and attached algae. However, both taxa include relatively tolerant species and their presence in such large numbers is probably reflective of the algal abundance that results from nutrient enrichment (Hilsenhoff, 1988).

A total of eight fish species were collected in seine samples at stations 1 and 4. Numbers collected at each station are shown in Table VI.2.

Table VI.2
Fish Species Collected at Stations 1 and 4

Generic name	Common name	Station 1	Station 4
<i>Dorosoma cepedianum</i>	Gizzard shad		1
<i>Notropis venustus</i>	Blacktail shiner	24	31
<i>N. lutrensis</i>	Red shiner		2
<i>Pimephales vigilax</i>	Bullhead minnow		1
<i>Micropterus punctulatus</i>	Spotted bass	8	
<i>Lepomis megalotis</i>	Longear sunfish	5	
<i>Gambusia affinis</i>	Mosquito fish	14	1
<i>Sarotherodon aureus</i>	Blue tilapia	4	

Both collections are somewhat depauperate, but the one from the upstream station has a much more eq-uitable distribution of individuals among species, and includes two predacious species that have no equivalents at Station 4. Blue tilapia is an introduced herbivorous species.

Endangered and threatened species of known or possible occurrences in Williamson County are listed in Table VI.3.

Peregrine Falcon

The peregrine falcon is a medium to large falconid whose populations were decimated largely due to the effects of environmental pollutants such as DDT (Farrand 1983). One of the two subspecies found in Texas (*Falco peregrinus tundrius*) is considered endangered by both the USFWS and TPWD, while the other subspecies (*F. p. anatum*) is listed as threatened by the USFWS and endangered by TPWD.

The peregrine falcon is a swift raptor which feeds almost exclusively on birds ranging in size from that of small passerines to ducks (Bent, 1938). Peregrine falcons occur only as migrants in north Texas (USFWS 1984). During this time almost any area with trees or other perch structures and an adequate supply of prey might be considered potential habitat for this species. Thus, the importance of relatively small acreages considered individually in terms of peregrine falcon value is small.

Whooping Crane

To the American public, the whooping crane is perhaps the best known of America's endangered species. The species is extremely rare with just over 90 individual birds existing in the traditional wild flock (Johnson, 1968). It is listed as endangered by both USFWS and TPWD.

The whooping crane is the tallest native avian inhabitant of Texas, where it is a winter resident of shallow wetland habitats of the Aransas National Wildlife Refuge and surrounding areas of the Gulf Coast (Farrand, 1983). Oberholser (1974) described the whooping crane as an omnivore that feeds on crabs, shrimp, frogs, crawfish, plant roots and tubers, acorns, and sorghum and other grains.

Portions of north Texas, including Williamson County, lie within the migratory corridor that whooping cranes follow enroute to their nesting grounds in Wood Buffalo National Park, Canada (Whooping Crane Recovery Team, 1980). However, in Texas there are no know regular migration stopover points such as are found in certain areas of Nebraska; in fact, there are only a few scattered confirmed ground sightings of whooping cranes anywhere in Texas other than on the coastal wintering grounds (Whooping Crane Recovery Team, 1980; 1981).

Interior Least Tern

The least tern is a miniature member of the family Laridae, which includes the gulls, terns and skimmers. Like other members of the family, the least tern is an excellent flier and is found in association with aquatic habitats and their margins, especially in coastal regions. It feeds by hovering above the water and then diving for small fish and invertebrates at or near the surface (Oberholser 1974).

Inland breeding populations of the least tern are considered by some to be taxonomically distinct at the subspecific level from the more common coastal breeding populations; however, not all workers agree (Endangered Species Division, 1986). The interior form breeds locally in the Missouri Valley along the larger streams from North Dakota south to the Brazos River system of North Texas. Here it nests in pairs or small colonies on river sandbars or sandflats, but is otherwise similar in behavior to the coastal subspecies (Johnsgard, 1979; Oberholser, 1974). Nesting and/or summer occurrence has been confirmed for areas along the Red River between Texas and Oklahoma (Ducey, 1981). During winter the interior least tern ranges from south Texas to Oaxaca, Mexico (Oberholser 1974). Alterations in its preferred riverine habitat have apparently caused a decline in populations. This decline has led to the listing of the interior least tern as endangered by both the USFWS and TPWD.

Black-capped Vireo

The black-capped vireo is an inhabitant of well-drained bushy or thicket-covered hills typical of many parts of the Edwards Plateau (Oberholser 1974). The species has become very rare in parts of its historic range as a result of nest parasitism by the brown-headed cowbird (*Molothrus ater*) and land use practices (eg. fire suppression, pasture maintenance) that reduce the availability of its successional nesting habitat (Marshall et al, 1985; Grybowski, 1986; Austin, 1987; Wahl and Parent, 1988).

American swallow-tailed kite

The kite is currently considered threatened by TPWD, and is under review by USFWS as a "Category 2" species (further biological research needed to evaluate its status). The species prefers wetland woodlands and associated native prairie type habitats.

White-faced Ibis and Wood Stork

Both are threatened avian species that do not breed in or near Williamson County (in the United States the latter nests only in Florida). However, both species often exhibit a postnesting wandering period during which they may occur very irregularly at inland locations (Oberholser, 1974).

VII.D Cultural Resources Along the San Gabriel River West of Georgetown

VII.D.1 Introduction

The project area extends along the banks of the San Gabriel River downstream from Georgetown, in Williamson County, extending north along the courses of Berry Creek and Pecan Branch and south along Mankin's Branch and Smith Branch. The files of the Texas Archaeological Research Laboratory at the University of Texas and at the Texas Historical Commission were inspected for previously recorded cultural

resource sites in and around the study area. Following a brief background of the prehistory and history of the region, all of the previously recorded cultural resource sites in the study area are listed and briefly described below. Where possible, observations have been made on their archaeological or historical value and potential eligibility for the National Register of Historic Places. These evaluations are followed by a general discussion of site location parameters in the region and recommendations for treatment plant locations that would lessen the potential impact on cultural resources of the area.

Cultural resources in the State of Texas are potentially protected by both Federal and State, and in some cases by county and municipal, legislation and regulations. The focal point of the Federal legislature is the National Historic Preservation Act of 1966 as amended (NHPA). This legislation creates the National Register of Historic Places (NRHP) and states that the Advisory Council for Historic Preservation (ACHP) must be afforded the chance to comment when any cultural resources eligible for inclusion on the National Register are present in an area affected by Federal agency actions or actions funded or permitted by Federal agencies. In effect, the NHPA and associated Federal agency regulations, as currently interpreted, generally require a complete archaeological survey to be undertaken in conjunction with most Federal or Federally-permitted projects, particularly in previously unsurveyed areas in regions where cultural resources are expected. Sites discovered during survey must be evaluated for their potential eligibility to the NRHP. This evaluation must be approved by the State Historic Preservation Officer (SHPO). If significant resources (i.e., eligible for the NRHP) are located during archaeological survey conducted under the auspices of NHPA, these resources must be protected or their destruction mitigated by approved data recovery programs.

In addition to the Federal cultural resource protection process, sites on land owned or controlled by political subdivisions of the State fall under the purview of the Texas Antiquities Code. This code identifies all archaeological sites on land belonging to municipalities, water districts and other political subdivisions as State Archaeological Landmarks. Should any potential sites located on lands earmarked for wastewater treatment plant construction be eligible for formal designation of landmark status under the code, some measure of protection or mitigation of impact may be necessary. Administration of such sites and formal designation is done by the Texas Antiquities Committee (TAC). In practice, when projects involve both Federal and State agencies or funding, either the TAC or the SHPO will take the lead in determining the eligibility of the archaeological site for protection under the various legislative acts.

VI.D.2 Cultural Setting

VI.D.2.a Cultural Background

Following initial general syntheses by Pearce (1932) and Sayles (1935), Kelley (1947) compiled what was probably the best early chronological framework available for prehistoric period in Central Texas. Suhm, Krieger and Jelks' (1954) treatment of the Central Texas region in their massive cultural synthesis for the entire state tended to be somewhat more conservative than Kelley's. Suhm's (1960) early review of the archaeology of Central Texas, which extended the 1954 Suhm, Krieger and Jelks presentation, was followed by a number of attempts to refine the chronology for limited periods (Jelks 1962). Initial subregional studies (Johnson, Suhm and Tunnel 1962; Sorrow, Shafer and Ross 1967) were followed in 1967 by the first statistical analysis of the available data (Johnson 1967).

At the most general level, the prehistory of Central Texas reflects four general stages, as originally defined by Suhm, Krieger and Jelks (1954). With revised terminology, these are the Paleoindian, the Archaic, the Late Prehistoric and the Historic. The Paleoindian stage was originally devised to encompass the earliest inhabitants of the New World, spreading across the continent in the waning years of the Pleistocene era. These cultures are distinguished by their distinctive lithic technology, including a series of well-made lanceolate projectile points such as Clovis, Folsom and Plainview. Site types include both rock shelters and open sites. These peoples have been described as nomadic big-game hunters and many of the early sites of this period are associated with now extinct large mammals of the Pleistocene era. The first occupations of the New World, however, may have occurred much earlier than the 11,500 B.P. date often given for the early Clovis culture and, outside of the Great Plains and the Rocky Mountain West, big game hunting may not have been the most important economic pursuit (e.g., Black and McGraw 1985:36-7).

Providing a firm date for the end of the Paleoindian period is difficult, primarily because of the gradual warming trend which marks the end of the Pleistocene. Clearly, however, the warming climates at the end of the Pleistocene can be associated with noticeable cultural change. The later Archaic cultures, traditionally dated as beginning around 8,500 B.P., were distinguished from the earlier Paleoindian cultures by increasingly regionalized traditions in the former with a perceived broadening exploitation of the available resource base. As generally understood, these peoples began to settle into their environment, becoming familiar with the resources of the regions that they inhabited. This is a trend which must have begun during the latter part of the Paleoindian stage and continued throughout most of the Archaic. While the Early Archaic period retained many technological similarities to the Paleoindian period, the Middle Archaic hunter-gatherers are increasingly distinctive. In Central Texas, the appearance of the burned rock midden site type distinguishes this period. Toward the end of the Archaic period, population densities may have increased and connections may have been established between the hunter-gatherers of

Central Texas and the complex cultures developing in surrounding regions. Large burial sites in some parts of south central and coastal Texas during the Late Archaic may indicate intensive reoccupation of certain sites or, possibly, increasing sedentarism of the cultural groups.

The final prehistoric period in Texas, the Late Prehistoric, is marked by the introduction of new technologies, including the bow and arrow and ceramics, as well as potentially new adaptive strategies. While the earliest part of this period, beginning about A.D. 500, may indicate introduction of new technologies into existing cultural patterns, the latest part seems to indicate the possible actual introduction of peoples following a southward extension of the range of the bison. Although the Late Prehistoric stage has been traditionally separated from the Archaic, Prewitt (1981) has cogently argued against the separation of this period into a different stage.

Later attempts (Weir 1976; Prewitt 1981; 1983) have further refined the Central Texas chronology beyond this simple four stage model and elucidated the culture history of the area. In the most complex formulation to date, Prewitt (1981; 1983) has subdivided the Archaic and Late Prehistoric into eleven named phases. From earliest to latest, these phases are Circleville, San Geronimo, Jarrell, Oakalla, Clear Fork, Marshall Ford, Round Rock, San Marcos, Uvalde, Twin Sisters, Driftwood, Austin and Toyah. Although there is little question of the general trends that Prewitt recognizes (many of them were recognized as early as Suhm, Krieger and Jelks' work and some were identified previously by Johnson), the actual dating of periods may be problematic as is the primary association of artifacts that would allow the appropriate use of the phase concept (Johnson 1986).

Although the Historic stage theoretically begins in Texas with the arrival of Alvar Nunez Cabeza de Vaca and the survivors of the Narvaez expedition on the Texas coast in 1528, there may have been earlier landings, notably by the expeditions sent by Francisco Garay, then governor of Jamaica, to the mouth of the Rio Grande between 1519 and 1523 (Salinas 1986:34-8). In any case, the influences of European colonization were not strongly felt for several centuries. By the middle of the 18th century, however, massive depopulation and cultural disintegration was evident among native Indian groups.

Although several early Spanish expeditions probably crossed southeastern Williamson County, the earliest expedition which may have entered the study area was that of the Marques de Aguayo in 1721. This large expedition may have crossed the San Gabriel near Georgetown (Scarborough 1973:56). The first settlement in the area was that at Mission San Xavier founded in 1746 on the San Gabriel River just east of the Williamson County line. Eventually three missions were built, all of which were moved in 1756 to the San Saba River.

Anglo settlement of Williamson County was slow in coming. Besides the Robertson Colony, there was very little settlement in the county prior to the Texas Revolution although the area was the scene of considerable activity. Several trails traversed the county, perhaps the most notable of which was the Double File Trail which crossed the San Gabriel downstream from Georgetown, within the present study area. The ill-fated Santa Fe expedition camped at this crossing on the night of the 20th of June, 1841, before heading north toward New Mexico (Scarborough 1973:99-100). During the fall and winter of 1846, a company of Rangers was stationed near this crossing (Scarborough 1973:109).

The 1840s brought increased settlement in the area and, in 1848, the town of Georgetown was founded and Williamson County was formed from Milam County by the Texas Legislature. Early settlement in the project area included communities on Berry Creek (Johnsonville and Berry's Creek) and at the confluence of Mankin's Branch with the San Gabriel River (Cooke Settlement). John Berry built a mill on Berry Creek as early as 1846, while James Francis Towns built a mill in 1870 near the Double File Trail crossing. Later, in 1892, Harvey T. Stearns built a gin at Mankin's Crossing. Early schools were established on Mankin's Branch (including both Mankin's and Bailey schools), at Fairview, between Georgetown and Weir, and at East View, four miles east of Georgetown on Highway 29 (Scarborough 1973).

VI.D.2.b Previous Archaeological Research

The more than 700 cultural resource sites which have been recorded in Williamson County reflect not only the high intensity of human utilization of the area both prehistorically and historically, but the frequency of archaeological studies in the area. Much of the archaeological investigations in north central Williamson County have been associated with the two major reservoirs on the San Gabriel River, the North Fork (now Lake Georgetown) and Granger (formerly Laneport) lakes. These two areas were initially surveyed by the Texas Archaeological Salvage Project at the University of Texas at Austin (Shafer and Corbin 1965). A total of 79 archaeological sites were recorded for both of these reservoir areas.

A number of sites were tested in the North Fork Reservoir area. Most of these early projects were conducted by the Texas Archaeological Salvage Project, later the Texas Archaeological Survey (TAS). Among the early test excavations were those at the John Ischy site (Sorrow 1969) and the Barker site (Sorrow 1970). Sorrow (1973) later tested eight additional sites. Later, four additional sites were tested and additional surveys recorded 47 new sites (Jackson 1974). Further projects in the North Fork area included projects by Texas A&M (Patterson 1977; Patterson and Shafer 1980) and the Institute of Applied Sciences at North Texas State University (Sullivan, Hays and Humphreys 1976; Hays 1982).

Following the survey in the Granger reservoir area, testing was conducted at three sites by Eddy (1973). Prewitt (1974) conducted limited excavations at the Loeve-Fox site. Somewhat later, Texas A&M con-

ducted excavations at 41WM21 at Granger dam (Shafer et al. 1978) and at three prehistoric sites in the Hoxie Bridge area (Bond 1978). Prewitt (1982) returned to excavate the Loeve-Fox as well as the Loeve and Tombstone Bluff sites and NTSU conducted excavations at eight sites and tested four other sites in the reservoir area (Hays 1982).

Within the present study area, there have been only a few small archaeological surveys, most of which have recorded cultural resource sites. The earliest professional survey in the study area was that of Whitsett (1977) who recorded one site on the West Fork of Smith Branch southeast of the City of Georgetown. This site was not recommended for further work. In 1979, Kleinschmidt recorded three archaeological sites along Pecan Branch east of FM 418 in conjunction with a proposed LCRA electric substation. Surface collections were made at the more extensive of the three, 41WM430, but none were recommended for further work (Kleinschmidt 1979). Shortly thereafter, Whitsett and Fox (1979) conducted an archaeological survey in conjunction with a planned expansion of the existing wastewater treatment facility at Georgetown. Two sites were recorded, one of which was noted as destroyed and the other, 41WM432, was determined eligible for the NRHP. A 1984 survey of a proposed Texas Department of Highways and Public Transportation highway borrow pit found a low level scatter of possible prehistoric material in a large cobble field on Berry Creek but recorded no sites (Weir 1984). Most recently, a survey by Cole (TARL site files) for a planned wastewater treatment facility for the Dove Springs subdivision recorded a site on a tributary of Mankin's Branch. All of the sites recorded in these surveys are described in greater detail below.

VI.D.3 Previously Recorded Sites

VI.D.3.a Prehistoric Resources

A total of 17 prehistoric archaeological sites has been recorded within the boundaries of the study area. None of these sites have been formally listed on the NRHP (Steely 1984), although at least one has been determined to be eligible. No determination of National Register eligibility has been made for most of the remaining sites. From the documentation available, it is possible only to make very general statements regarding the value of individual sites other than those for which previous evaluations have been made. The list below summarizes these previously recorded prehistoric sites. Since archaeological survey has only been conducted for a minuscule portion of the area, it can only be assumed that these sites may be representative of a much larger sample of sites actually present.

41WM141

This prehistoric site is located on a gently sloping eastern edge of Rabbit Hill 550 meters south of Smith Branch upstream from its confluence with the San Gabriel River. The underlying bedrock at the site is

mapped as part of the Eagle Ford Group and Buda Limestone Formation (Barnes 1981). Soils are Houston Black Clay with eroded 3-5 percent slopes (Werchan and Coker 1983). Elevation of the site is 890 feet (271 m) MSL. Erosion and plowing have both disturbed the integrity of the site.

Site 41WM141 consists of one burned rock midden and a lithic scatter of unreported size and depth. The recorder has a private collection from this site (TARL site files). The paucity of information precludes a complete evaluation. The Houston Black Clay does not often yield deeply buried cultural materials, but if the midden were intact, the site could be eligible for the National Register.

41WM280

This prehistoric site, recorded by Whitsett (1977), is located on the floodplain south of the West Fork of Smith Branch's upstream from the confluence of Smith's Branch with the San Gabriel River. The geology is mapped as fluvial terrace deposits overlying Del Rio Clay and the Georgetown Formation substrate (Barnes 1981). Soils are Heiden clay with 1-3 percent slopes (Werchan and Coker 1983). Elevation of the site is 720-740 feet (219-226 m) MSL. The site has been plowed.

Cultural materials cover an area approximately 75 X 40 meters in size with apparently no depth. A sparse scatter of lithic debitage and artifacts, possible burned rock, and 1880s glass and pottery are reported from the site (TARL site files). The site reportedly represents occupations during the Middle and Late Archaic periods. Plowing at the site has apparently damaged whatever contextual integrity the site may have had and Whitsett (1977) does not recommend further work for the site. This site does not appear to be eligible for the National Register.

41WM378

This prehistoric site, recorded by Kleinschmidt (1979), is located along the southern bank of Pecan Branch and may once have extended across to the northern side as well. Underlying sediments are mapped as fluvial terrace deposits (Barnes 1981). Soils are Fairlie clay with 1-2 percent slopes (Werchan and Coker 1983). Elevation of the site is 700 feet (213 m) MSL. Vegetation is reported to be Bermuda grass and dense areas of weeds. The site has been severely eroded according to Kleinschmidt (TARL site files).

Lithic debitage covers an area 100 by 20 meters (approximately E/W) with disturbed soil approximately 40 centimeters deep. Cultural materials consist of natural chert cobbles, cores, flakes, and one biface. Cultural affiliation is unknown. Disturbances at this site apparently preclude recovery of significant information and Kleinschmidt (1979) does not recommend this site for further work. Although there is a slight possibility of shallowly buried deposits, it does not appear likely that the site is eligible for the NRHP.

41WM379

This prehistoric site, also recorded by Kleinschmidt (1979), is located in a plowed field 90 meters south of Pecan Branch upstream of its confluence with the San Gabriel River. It is just south of 41WM378. Underlying geological sediments are mapped as fluvial terrace deposits (Barnes 1981). Soils are Fairlie clays with 1-2 percent slopes (Werchan and Coker 1983). Elevation of the site is 700-710 feet (213-216 m) MSL.

The site covers an area approximately 100 X 100 meters in size with no obvious depth. Cultural materials consist of natural chert and limestone cobbles, cores, and large flakes. Five concentrations of lithic material were noted by Kleinschmidt (1979). None of these five discrete concentrations of material can be established as contemporaneous. The presence of natural cobbles and large flakes probably indicates use of the site as a resource procurement area. The plowed field location of this site and the lack of depth detracts from its potential to yield cultural information. Kleinschmidt (1979) did not recommend this site for further work and it is apparently not eligible for the National Register.

41WM421

This prehistoric site is located on an alluvial terrace 120 meters north of the San Gabriel River upstream from its confluence with Pecan Branch. Alluvium and fluvial terrace deposits are mapped in the area (Barnes 1981). The soils are predominantly Krum silty clay with 1-3 percent slope (Werchan and Coker 1983). Elevation of the site is 650-657 feet (198-200 m) MSL. At the time of recording, grasses covered the terrace which was being eroded by an arroyo to the east and along a dirt road to the west. In addition, two abandoned modern buildings lie on top of the site.

Covering an acre, the site consists of lithic material including bifaces, flakes, cores and burned rock. Brookshire (TARL site files) notes the terrace deposit is 25 feet (8 m) thick, but does not give a depth for the cultural deposit. No shovel tests were excavated. Some of the burned rock was noted as having been washed downslope.

Although, erosion was reported for both the east and west margins of the site and modern buildings were noted, the depth of the alluvial sediments suggests the potential for intact cultural deposits. The original recorded suggested that it warranted further investigations. It is likely that this site will need testing to determine its potential for National Register.

41WM422

This prehistoric site is located in a plowed field adjacent to modern structures, 400 meters north of the San Gabriel River. This site is one of two sites on the gently sloping terrace; the other is 41WM423. The un-

derlying sediments are mapped as alluvium and fluvial terrace deposits (Barnes 1981). The site appears to be in an active floodplain. Soils are Krum silty clay with a mixture of 0-1 percent and 1-3 percent slope (Werchan and Coker 1983). The site is at an elevation of 620 feet (189 m) MSL.

The site materials are scattered over an area not more than 50 meters in diameter and have an unknown depth. Cultural materials consist of lithic debitage and cores of chert. No features were observed. Site 41WM422 may represent a primary reduction loci as the recorder notes abundant naturally occurring chert in the vicinity (TARL site files). The potential for buried deposits is high given the nature of the location. Although the modern buildings may have disturbed the integrity of the site, it may need to be tested to determine NRHP eligibility.

41WM423

Site 41WM423 is located in a plowed field 0.8 kilometers north of the San Gabriel River. This site is the second of two sites on the gently sloping left bank of the river; the other is 41WM422. The underlying sediments are mapped as fluvial terrace deposits bordering on the Austin Chalk Formation (Barnes 1981). Soils are Krum silty clay with a mixture of 0-1 percent and 1-3 percent slope (Werchan and Coker 1983). The site is at an elevation of 650 feet (198 m) MSL.

The extent of the site is no more than 50 meters in diameter with an unknown depth. Cultural materials include a scatter of flakes, cores and chips of chert. The recorder (TARL site files) notes the abundance of naturally occurring chert possibly indicating a primary reduction loci. The lack of available information precludes statements about the site's potential information yield. National Register eligibility can not be determined without further testing.

41WM424

This prehistoric site is located in a plowed field 350 meters south of the San Gabriel River downstream from its confluence with an unnamed south bank tributary. It is part of a complex of sites on this steep bluff; these other sites are 41WM425, 41WM426 and 41WM427. The geology is mapped as fluvial terrace deposits overlying the Austin silty clay with 1-3 percent slope (Werchan and Coker 1983). The site is at an elevation of 650 feet (198 m) MSL. It is adjacent to a dirt road, a tank and two modern buildings.

The size of the site is 9 by 12 meters. Depth is unknown. Lithic debris and cores were the only cultural materials noted. No features were observed. Historic plowing of this site has disturbed the context of the cultural materials. This disturbance is further compounded by the existence of the modern structures. No information is provided on potential depth of cultural material at the site, however, Further testing may be required to determine National Register eligibility.

41WM425

Site 41WM425, at the time of recording, was located in the heavily wooded slopes 500 meters from the San Gabriel River and downstream from its confluence with an unnamed south bank tributary. This site is part of a complex of sites including 41WM424, 41WM426, and 41WM427. The geology is mapped as fluvial terrace deposits overlying Austin Chalk (Barnes 1981). Soils are Altoga silty clay loam with 3-5 percent slope and experiencing sheet and gully erosion (Werchan and Coker 1983). The site is at an elevation of 660 feet (201 m) MSL.

The site is 60 by 15 meters in size and is covered by 5 centimeters of humus. The soil was noted by Brookshire (TARL site files) to be no more than 2 meters in depth. A moderate amount of lithic material was observed including a large number of burned rock scattered across the site. Two bifaces, ground stone fragments, "hammerhead", flakes and cores were also seen.

Although some erosion has occurred and is continuing the large numbers of burned rock and the diversity of tools may suggest a camp site. The apparent depth of the soils and density of artifacts suggest that the site warrants testing to determine National Register eligibility.

41WM426

This prehistoric site is located on a terrace 520 meters south of the of the San Gabriel River downstream from its confluence with an unnamed south bank tributary. Adjacent to a dirt road, it is part of a complex of sites including 41WM424, 41WM425 and 41WM427. The geology is mapped as fluvial terrace deposits overlying Austin Chalk (Barnes 1981). The soils are very gravelly clay loam of the Eddy series with 3-8 percent slope (Werchan and Coker 1983). At the time of recording the site was grass covered. The site is at an elevation of 650 feet (198 m) MSL.

The site is no more than 30 meters in diameter and has an unknown depth. It contains large amounts of lithic debris and cores, two pieces of which have been fire-cracked. Although Brookshire (TARL site files) does not give a depth of the deposit, the large amounts of cultural materials alluded to suggest the need for further work. Testing is necessary to determine National Register eligibility.

41WM427

Site 41WM427, at the time of recording, was located on the heavily wooded slopes 45 meters south of the San Gabriel River. It is part of a complex of sites including 41WM424, 41WM425 and 41WM426. The geology is mapped as alluvium and fluvial terrace deposits (Barnes 1981). The soils are very gravelly clay loam of the Eddy series with 3-8 percent slopes (Werchan and Coker 1983). The site lies at an elevation of 600-610 feet (183-186 m)MSL.

The site is 8 by 9 meters, and, although the depth of cultural materials was not noted, the terrace deposit is 3 meters deep. Cultural materials consist of small quantities of burned rock, exhausted cores, and flakes and chips. Although slope wash is evident and the cultural materials are few in number, the depth of the terrace deposit warrants further testing to determine if this site is eligible for the National Register.

41WM430

This prehistoric site, one of a series of three recorded by Kleinschmidt (1979), is located on the east bank of Pecan Branch, extending from the crest of a hill to the base of the slope. The underlying sediments are mapped as fluvial terrace deposits (Barnes). Soils are Fairlie clay with 1-2 percent slopes (Werchan and Coker 1983). Elevation of the site is 700-720 feet (213-219 m) MSL.

Site 41WM430 extends approximately 100 meters E/W by 500 meters NNW/SSE with only a thin soil cover. Prehistoric materials include large cores, observed at the bottom of the hill, small cores and modified and unmodified flakes, and bifaces were observed at the hill top. Kleinschmidt (TARL site files) noted that the dynamic soils may be partially responsible for the burying of small specimens. The slope wash is evident by the presence of larger cores at the base of the hill. The site is reported to be suggested of a lithic procurement area; however, the existence of bifaces and retouched specimens is contradictory unless testing cobbles was a secondary use of the site. The surficial nature of the site, even though it may be partially buried, implies low information yield. Kleinschmidt (1979) does not recommend further work at this site.

41WM431

This prehistoric site, recorded by Whitsett and Fox (1979), is located 500 meters from the south bank of the San Gabriel River upstream from its confluence with Smith's Branch. Underlying sediments include the Eagle Ford Group and Buda Limestone Formation (Barnes 1981). A mixture of soils is present consisting of Queeny clay loam at the site center surrounded by Sunev clay loam with 1-3 percent slope and Denton silty clay with 1-3 percent slope. The site ranges from 690-700 feet (210-213 m) MSL in elevation. It has been highly disturbed by the adjacent roads and sewage plant.

A thin scatter of lithic material and burned rock comprise this surficial site, 75 by 50 meters in size. No temporal diagnostics or features were observed. The highly disturbed nature of this site, as reported by Whitsett and Fox (1979) precludes high information yield. Following the recommendation of Whitsett and Fox (1979), the Texas Historical Commission has determined that this site is not eligible for the National Register.

41WM432

This prehistoric site, also recorded by Whitsett and Fox (1979), is located along a road above the banks of the San Gabriel River, 30 meters from the south bank upstream from its confluence with Smith's Branch. The geology is mapped as alluvium and fluvial terrace deposits (Barnes 1981) with soils of Sunev silty clay loam of 1-3 percent slope (Werchan and Coker 1983). Elevation of the site is 680-690 feet (207-210 m) MSL. In places at least 50 percent of the materials have been disturbed or totally removed.

A burned rock midden and associated lithic materials and snail shells cover an area 100 by 30 meters in size. The midden has a possible depth of a meter, while the northeast portion of the site may be only 20 centimeters deep where gravels are being exposed. Cultural materials consist of burned rock, lithic debitage, snail shells, possibly attracted by the organic materials, and one large stemmed biface. Whitsett and Fox (1979) place this site in the Archaic. The stemmed biface is considered early by the recorders. The only feature observed was the burned rock midden on the southwestern portion of the site.

The results of earth moving machinery and erosional processes have damaged portions of this site. However, the potential one meter depth to the midden suggests a high information yield. Following recommendations by Whitsett and Fox (1979), the Texas Historical Commission has deemed this site eligible for the National Register.

41WM540

This prehistoric site is located on a limestone bluff 150 meters south of Berry Creek, more than 10 kilometers upstream from its confluence with the San Gabriel River. Underlying bedrock is mapped as Fredericksburg Group limestone (Barnes 1981). Soils are of the Eckrant rock outcrop on gently rolling topography ranging from 1-30 percent slopes. Elevation of the site is 780-790 feet (237-240 m) MSL. Vegetation is reported to consist of sparse grasses, cedar scrub, pecan, oak and elm trees (TARL site files). Cattle grazing, hunting leases and looting have disturbed the contextual relationships of this site.

The lithic scatter covers an area 200 by 200 meters in size with a 20 m-diameter burned rock midden in the northeast section of the site. The bedrock is noted to be thinly covered in some areas of the site (TARL site files). Materials observed at the site consist of a Pedernales Point, thumbnail scrapers, and various bifaces. The burned rock midden was the only feature noted. Although the site has been surface collected and partially destroyed by pothunters, the large diameter of the midden and its surrounding lithic scatter suggests a high information yield. Further testing is necessary to determine if the site may warrant National Register status.

41WM690

This prehistoric site is located on a rise 30 meters south of the north bank of Cowan Creek. An unnamed drainage forms the northern boundary. The site is more than 10 kilometers upstream of the confluence of Berry Creek and the San Gabriel River. Underlying bedrock is mapped as the Fredericksburg Group (Barnes 1981). Soils in the site area consist of Georgetown stony clay loam with 1-3 percent slope (Werchan and Coker 1983). The site lies at an elevation of 810-815 feet (247-248 m) MSL. Heavy weed cover was noted by the site's original recorders (TARL site files). Vegetation at the site consists of various grasses with dense weeds and a mixture of pecans, live oaks, elms and sycamore. The site area has been cultivated in the past. It has been disturbed by looters in the last 10-15 years. Some of the looters' pot-holes were noted to be 30-50 centimeters in diameter.

The site contains a burned rock midden 175 meters east-west and approximately 200 meters north-south with lithic debris extending to the south and northwest. At least 50 centimeters of fill was observed in the potholes, but the recorders note that the site may be 2-3 meters in total depth (TARL site files). Large amounts of burned rock were observed but without intact hearth features. The recorders reported the removal of three partial human skeletons from the midden proper and noted the partial exposure of human bone. Two tibias were collected by the recorders from these recent exposures. Cultural material consists of large amounts of lithic debris, including flakes and chips, cores, biface fragments (mostly with manufacturing breaks), limestone, quartzite and possible granite manos, and a cluster of five grinding slabs. Faunal material from the site included the remains of deer, rodent and a bison bone fragment as well as some burned bone. Two features were observed, one being the midden itself, and the other being the apparent human burial. The burial may represent a cairn feature. The site appears to date to the Archaic period and probably was a campsite.

The wealth of cultural material and the possibility of deeply buried and intact deposits suggest a prime candidate for controlled excavations. Continued vandalism and the owners' plan to develop the area are immediate threats to the site. The potential for high information yield prompted the recorders to suggest its designation as a State Archaeological Landmark and its eligibility for the NRHP.

41WM735

This prehistoric site, recorded by Cole (1987) in a survey of the proposed Dove Springs wastewater treatment plant, is located at the confluence of two branches of a major tributary of Mankin's Branch, upstream from its confluence with the San Gabriel River. The underlying sediments are mapped as undivided Del Rio Clay and Georgetown Formation (Barnes 1981). Soils are Houston Black Clay with 1-3 percent slopes (Werchan and Coker 1983). The site has recently been plowed.

The recorder reports a thin lithic scatter within which was a 30 x 16 meter area of burned limestone and chert which is interpreted as a disturbed burned rock midden. Among the cultural material observed at the site, in addition to flakes, chips and burned rock, were several cores and two side scrapers. No diagnostic artifacts were observed and no intact features were noted. The site has been recommended as not eligible for inclusion on the NRHP, but no formal determination has yet been made (THC project files).

VI.D.3.b Historic Resources

A total of 47 historic sites have been recorded in and adjacent to the proposed treatment plant study area in conjunction with the historic resource survey of Georgetown conducted for the Georgetown Heritage Society (Hardy, Heck and Moore 1984). None of these sites have been assigned state trinomial site numbers, but some of the individual sites have been nominated for the NRHP as part of the Georgetown National Register District. Individual information is not available on many of these sites. Instead, the sites are summarized by area and by the low, medium and high priority categories established in the original survey report.

Those properties in the Georgetown Extraterritorial Jurisdiction area which were considered eligible for the NRHP as part of a Multiple Resource Area District include the J. J. Johnson House on Rabbit Hill Road, just outside of the study area to the south, another house on County Road 188 near Smith's Branch, and the MKT railroad bridge east of town. The Johnson house has been placed on the National Register of Historic Places. The house on Smith Branch has subsequently been moved and is no longer considered eligible for the NRHP, while the railroad bridge has been passed by the NRHP State Board of Review and is considered eligible for the Register, although it has not yet been formally approved. Another structure, located east of Georgetown on Highway 29, has been nominated for the NRHP and has also passed the Board of Review but has not yet been formally placed on the Register.

Among the other high priority historic sites not nominated for the NRHP are a cemetery on Rabbit Hill Road, three residences on FM 1460, three residences on Highway 29 and a residence on County Road 152. Ten additional medium probability sites were noted, all residences with the exception of one cemetery and a barn and standing chimney all on FM 971. It should be noted that while only a few of these sites have been nominated or considered eligible for the NRHP as structures, others among them may have archaeological value that would support their listing on the NRHP.

Not included on this list are a series of sites described in Scarbrough's (1973) Williamson County history. These sites, some of which were noted briefly in the background section, could be assumed to be significant historic archaeological sites should any undisturbed remains be found on the ground in these areas.

Among the areas that may be particularly significant are the Town's Mill/Double File Trail crossing, Mankin's Crossing, Berry's Mill, Berry's Creek and Johnsonville settlements, and some of the early county schools.

VI.D.4 Site Location Patterns

Although less than one percent of the study area has been subjected to archaeological survey, patterns of site location can be deduced from the small sample of recorded sites and the pattern of site location at nearby Georgetown and Granger Lakes. Although the vast majority of the survey has been conducted in the bottomlands of the San Gabriel River in conjunction with water resources and wastewater projects, a small amount of upland survey has been conducted southwest of Georgetown in conjunction with the Georgetown Heritage Society historic resource survey (Kleinschmidt 1984).

As is typical of prehistoric sites in many areas, the primary location factor is proximity to water. Sites will increase in density, size, depth and significance as a direct function of distance to drainage and with the significance of the drainageway. A corollary to this statement is that sites tend to be even more frequently located at the confluence of drainages. A minor corollary, important primarily in the Balcones Escarpment area, is that sites are frequently associated with springs.

A secondary location factor is the availability of stone raw materials for tools. Site density seems to be slightly greater in those areas where lithic resources are available. Whether this is a factor of visibility, or one of cultural patterns, is not clear. Availability of limestone is a key factor in the location of one particular site type, the burned rock midden. Summarizing the site location factors for prehistoric sites, we have:

- close to drainages;
- increased density near larger drainages;
- close to stream confluences;
- close to lithic raw materials;
- close to springs.

Although there is insufficient information available for a detailed treatment of sites by landform category, there are some important criteria that may be applicable to the potential significance of sites found within these areas. Although prehistoric site significance is not directly linked to landform, there is often a very good correlation between site value and the potential for site preservation, which is generally linked to landform type.

In general, sites buried in alluvial landforms will be more difficult to recognize on survey, potentially calling for mechanical methods of identification. They will be more difficult and expensive to assess and mitigate, if such actions, are necessary. Since the density of sites in alluvial areas is often great, the chance of encountering a potentially significant site is likely to be high in alluvial areas. However, very recent alluvial formations, such as the low modern point bar deposits, which may have formed in the last 500 to 1000 years, are less likely to contain significant deposits. Very ancient alluvial landforms, which ceased forming prior to 12,000 years ago, will also be unlikely to yield significant prehistoric sites.

Although sites are found on older terraces and on eroded Cretaceous landforms, these sites are much less likely to exhibit buried material and thus, less likely to provide new and significant cultural information. One notable exception to this generalization is the burned rock midden, a prehistoric mound consisting of fractured limestone rocks associated with both stream terraces and upland areas. Generally, the co-occurrence of exposed limestone formations and drainages are key locational factors for this type and, thus, it is common along and above the Balcones Escarpment area. Wherever this site type is found, it is possible that it may contain significant information. Location of facilities below the City of Georgetown will greatly reduce the possibility of encountering this site type.

Summarizing the factors which influence site significance, we have:

- Alluvial areas, where buried sites may be highly significant;
- Very recent alluvium and ancient terraces, where sites are less likely to be significant;
- Cretaceous deposits, where buried sites are rare with the exception of the burned rock midden in limestone rich areas.

Historic site locations depend on slightly different criteria than prehistoric sites. The primary factors in their location is transportation axes, such as roads and railroads. The intersection of such routes with drainages, as at the Double File Trail and Mankin's Crossings, is a prime location for historic resources. It is important to note, however, that roads change through time; the absence of a modern road does not necessarily indicate the absence of significant historic resources. A detailed historic background of a specific area can usually pinpoint key areas, if not specific historic resources, that may be significant in the history of a particular area. Previously unknown historic sites are not infrequent, however, and archaeological survey may be necessary to locate all potential historic resources. Unlike prehistoric sites, there is little areal correlation with site significance. Age, physical condition and potential contribution to regional history are more important criteria for the determination of site significance.

VI.D.5 Recommendations

The criteria above will provide a general guide to the archaeological potential for various areas. While cultural resources are not likely to be a fatal flaw to wastewater treatment plant construction, prior consideration of historic and archaeological sites is an important planning tool. The mitigation of project impacts to an archaeological site can add significant unexpected expense to any project. It is therefore recommended that as options for plant siting are narrowed, a continued dialogue is maintained with an archaeologist to prevent at least the most obvious problems. Brief reconnaissances would be useful for potential plant sites in the intermediate phase of the siting process.

Because of the density of archaeological sites within the region, a complete archaeological survey of any proposed treatment facility is recommended. This is likely to be required by the various agencies involved, either the Environmental Protection Agency or the Texas Water Development Board. Because archaeological survey can be expensive, particularly in an alluvial area, it is recommended that the actual site be chosen prior to 100 percent cultural resources survey. It is emphasized, however, that an archaeologist be included in all stages of the planning to avoid the potentially unnecessary cost of locating any proposed development on a significant cultural resource.

VI.E References Cited

- Barnes, Virgil 1981 Geologic Atlas of Texas. Austin Sheet. Austin: Bureau of Economic Geology. The University of Texas at Austin.
- Black, Stephen L. and A. Joachim McGraw 1986 The Panther Springs Creek Site: Cultural Change and Continuity Within the Upper Salado Creek Watershed, South-Central Texas. San Antonio: Center for Archaeological Research, The University of Texas at San Antonio, Archaeological Survey Report, No. 100.
- Blair, W. Frank 1950 The Biotic Provinces of Texas. Texas Journal of Science. 2:93-117.
- Bond, Clell L. 1978 Three Sites at Hoxie Bridge, Williamson County, Texas. Texas A&M University. Anthropology Laboratory, Report No. 43.
- City of Austin. 1987. Summary status report for the black-capped vireo in/near Austin, Texas, and additional unpublished material. Department of Environmental Protection, City of Austin, Texas.
- Cole, Nancy Mottashed 1987 Cultural Resources Survey of the Proposed Dove Springs Wastewater Treatment Facility, Williamson County, Texas. Report prepared for the Dove Springs Development Corporation, Georgetown, Texas.

- Collins, E. W., 1987, Characterization of fractures in limestones, northern segment of the Edwards aquifer and Balcones Fault Zone, Central Texas; Gulf Coast Association of Geologic Societies, Transactions, v. 37, p.43-53.
- Ducey, J.E. 1981. Interior least tern (*Sterna albigrons athalassos*): a summary. U. S. Fish and Wildlife Service, Pierre, South Dakota.
- Eddy, Frank W. 1973 Salvage Archeology in the Laneport Reservoir District, Central Texas. Report submitted to the National Park Service by the Texas Archaeological Survey, The University of Texas at Austin.
- Farrand, John. 1983. The Audubon Society Master Guide to Birding. Alfred A. Knopf, New York.
- Grzybowski, J. 1986. Pers. Comm. Ornithologist, Central State University, Edmond, Oklahoma.
- Hardy-Heck-Moore, Inc. 1984 Historic Resource Survey of Georgetown, Texas. Prepared for the Georgetown Heritage Society by Hardy-Heck-Moore, Inc, Austin, Texas.
- Hays, T. R. 1982 Archaeological Investigations at the San Gabriel Reservoir Districts, Central Texas. Denton: Institute of Applied Sciences, North Texas State University.
- Hilsenhoff, W.L. 1988. Rapid field assessment of organic pollution with a family-level biotic index. Journal of the North American Bentological Society 7(1): 65-68.
- Jackson, Marsha F. 1974 Archaeological Resources of the North Fork Reservoir Area: Results of the Survey and Testing 1970 Season. Report submitted to the National Park Service by the Texas Archaeological Survey, The University of Texas at Austin.
- Jelks, E. B. 1962 The Kyle Site: A Stratified Central Texas Aspect Site in Hill County, Texas. The University of Texas, Department of Anthropology, Archeology Series 5.
- Johnsgard, P.A. 1979. Birds of the Great Plains. University of Nebraska Press, Lincoln, Nebraska.
- Johnson, Frank. 1986. Public news release. Aransas National Wildlife Refuge.
- Johnson, Leroy, Jr. 1967 Toward a statistical overview of the Archaic cultures of central and southwestern Texas. Texas Memorial Museum Bulletin 12. University of Texas at Austin.
- Johnson, Leroy, Jr. 1986 A Plague of Phases. Bulletin of the Texas Archaeological Society. 57:1-26.

- Johnson, Leroy, Jr., Dee Ann Suhm and Curtis Tunnell 1962 Salvage Archeology of Canyon Reservoir: The Wunderlich, Footbridge and Oblate sites. Texas Memorial Museum Bulletin 5. University of Texas at Austin.
- Kelley, J. Charles 1947 The Lehmann Rock Shelter: A Stratified Site of the Toyah, Uvalde, and Round Rock Foci. Bulletin of the Texas Archaeological and Paleontological Society 18:115-128.
- Kleinschmidt, Ulrich 1979 Archaeological Assessment of the Proposed Gabriel Substation Site. Texas Archaeological Survey. The University of Texas at Austin. Technical Bulletin No. 34.
- Kleinschmidt, Ulrich 1984 Archaeological Report. In: Historic Resource Survey of Georgetown, Texas. Prepared for the Georgetown Heritage Society by Hardy-Heck-Moore, Inc, Austin, Texas.
- Kreitler, C. W., Senger, R.K., and Collins, E.W., 1987, Geology and hydrology of the northern segment of the Edwards aquifer with an emphasis on the recharge zone in the Georgetown, Texas, area; The University of Texas at Austin, Bureau of Economic Geology, contract report for: Texas Water Development Board, Interagency Contract No. IAC (86-87)-1046, 115 pp.
- Marshall, J.T., R.G. Clapp and J.A. Grzybowski. 1985. Status Report: *Vireo atricapilla* Woodhouse, black-capped vireo. 044 reham. Office of Endangered Species, U.S. Fish and Wildlife Service, Albuquerque, New Mexico.
- Moore, Gary 1978 Archaeological Test Excavations at Site 41WM21, Williamson County, Texas. College Station: Texas A&M University, Texas A&M Research Foundation Project No. 3446. Anthropology Department Report No. 37 (Revised).
- Oberholzer, H.C. 1974. The Bird Life of Texas. E. Kincaid (ed).
- Patterson, Patience E. 1977 A Lithic Reduction Sequence: A Test Case in the North Fork Reservoir Area, Williamson County, Texas. Bulletin of the Texas Archaeological Society. 48:53-82.
- Patterson, Patience E. and Gary L. Moore 1976 An Archaeological Study of North Fork and Granger Reservoirs: A Preliminary Report. Report submitted to the National Park Service by the Texas A&M Research Foundation in partial fulfillment of terms in Contract No. CX-1595-6-0008.
- Patterson, Patience E. and Harry Shafer 1980 Archaeological Surveys of Granger and North Fork Reservoirs: Volume II, The North Fork Report. Texas A&M University. Anthropological Research Laboratory, Report No. 38b.

- Pearce, J. E. 1932 The Present Status of Texas Archeology. Bulletin of the Texas Archaeological Society. 4:44-54.
- Prewitt, Elton R. 1974 Archaeological Investigations at the Loeve-Fox Site, Williamson County, Texas. Texas Archaeological Survey. The University of Texas at Austin. Research Report No. 49.
- Prewitt, Elton R. 1981 Cultural Chronology in Central Texas. Bulletin of the Texas Archaeological Society. 53:65-89.
- Prewitt, Elton R. 1982 Archaeological Investigations at the Loeve-Fox, Loeve and Tombstone Bluff Sites in the Granger Lake District of Central Texas. Texas Archaeological Survey, The University of Texas at Austin and Institute of Applied Sciences, North Texas State University, Denton.
- Prewitt, Elton R. 1983 From Circleville to Toyah, comments of central Texas chronology. Bulletin of the Texas Archaeological Society 54:201-238.
- Reilly, E.M. 1968. The Audubon Illustrated Handbook of American Birds. McGraw-Hill Book Co., New York.
- Salinas, Martin 1986 Historic Indian Populations of the Rio Grande Delta and Vicinity: An Approach to Definition of Basic Units. Unpublished M.A. Thesis. Department of Anthropology. The University of Texas at Austin.
- Sayles, E. B. 1935 An Archaeological Survey of Texas. Medallion Papers 17.
- Scarborough, Clara Stearns 1973 Land of Good Water (Takachue Pouetsu): A Williamson County History. Williamson County Sun Publishers, Georgetown.
- Schuetz, Mardith 1957 A Report on Williamson County Mound Material. Bulletin of the Texas Archaeological Society. 28:135-168.
- Shafer, Harry J. and James E. Corbin 1965 An Appraisal of the Archaeological Resources of the North Fork, South Fork, and Laneport Reservoir, Williamson County, Texas. Report submitted to the National Park Service by the Texas Archaeological Salvage Project.
- Sorrow, William M. 1969 Archaeological Investigations at the John Ischy Site: A Burnt Rock Midden in Williamson County, Texas. Papers of the Texas Archaeological Salvage Project, Number 18.
- Sorrow, William M. 1970 Archaeological Investigations at the Barker Site. Texas Archaeological Salvage Project, Research Report No. 1. Austin.

- Sorrow, William M. 1973 Test Excavations in the North Fork Area. Report submitted to the National Park Service by the Texas Archaeological Survey, The University of Texas at Austin.
- Sorrow, William R., Harry J. Shafer and Richard E. Ross 1967 Excavations at Stillhouse Hollow Reservoir. Papers of the Texas Archaeological Salvage Project. Number 18.
- Steely, James Wright (comp.) 1984 A Catalog of Texas Properties in the National Register of Historic Places. Austin: Texas Historical Commission.
- Suhm, Dee Ann, Alex D. Krieger and E. B. Jelks 1954 An Introductory Handbook of Texas Archeology. Bulletin of the Texas Archaeological Society. Volume 25.
- Sullivan, Tim, T. R. Hays and G. K. Humphreys 1976 Archaeological Testing at the North Fork Reservoir District, Central Texas. Report submitted to U.S. Army Corps of Engineers, Fort Worth District. Institute of Applied Sciences, North Texas State University, Denton.
- Texas A&M Anthropology Laboratory Staff 1976 A Preliminary Assessment of Cultural Resources in the North Fork and Granger Reservoirs, Williamson County, Texas. A Supplement to "An Archaeological Survey of Granger and North Fork Reservoirs, Preliminary Report". Report submitted to the National Park Service by the Texas A&M Research Foundation in partial fulfillment of terms in Contract No. CX-1595-6-0008.
- TDWR. 1978. Land Use/Cover Maps of Texas. Texas Department of Water Resources, Austin, Texas.
- TPWD. 1988. Letter listing endangered and threatened species in Williamson County. Texas Parks and Wildlife Department, Austin, Texas.
- USFWS. 1986. Draft recovery plan for the interior population of the least tern (*Sterna albifrons athalassos*). U.S. Fish and Wildlife Service, Endangered Species Division, Twin Cities, Minnesota.
- USFWS. 1987. Endangered and Threatened Species of Texas and Oklahoma. U.S. Fish and Wildlife Service, Albuquerque Regional Office.
- USGS. 1988. Unpublished water discharge and quality data. U.S. Geological Survey.
- Wahl, R. and L. Parent. 1988. A pair of rare birds. Texas Parks and Wildlife Magazine 44 (3): 35-37.
- WCRT. 1980. Whooping crane recovery plan. Whooping Crane Recovery Team., U.S. Fish and Wildlife Service, Washington, D.C.

WCRT. 1981. Whooping crane recovery plan: Revised appendix D., U.S. Fish and Wildlife Service, Pierre, South Dakota.

Weir, Frank A. 1976 The Central Texas Archaic. Unpublished PhD. Dissertation. Washington State University, Pullman.

Weir, Frank A. 1984 Letter to Texas Historical Commission dated April 1984.

Werchan, Leroy E. and John L. Coker 1983 Soil Survey of Williamson County. USDA Soil Conservation Service in cooperation with the Texas Agricultural Experiment Station.

Whitsett, Hayden 1977 An Archaeological Reconnaissance at Georgetown, Williamson County, Texas - C-48-1120-01. Texas Water Development Board Report.

Whitsett, Hayden and Daniel Fox 1979 An Archaeological Reconnaissance at the City of Georgetown, Williamson County, Texas - C-48-1120-01. Texas Water Development Board Report.

VII WASTEWATER TREATMENT PLANT ALTERNATIVES

VII.A Introduction

VII.A.1 Selection of Development Scenarios

Based on the water quality evaluations described in Section V, five development scenarios were selected for further consideration and economic analysis. The chosen scenarios were the ones most likely to enable a combined treatment load of 8 MGD at the least cost, while maintaining water quality levels in the receiving stream above the minimum DO level of 5 mg/L. An additional constraint that affected the choice of scenarios resulted from the TWC wasteload evaluation for Segment 1248, which directly impacts the operation of the existing Georgetown facility. The scenarios selected for further evaluation were:

- Scenario F2, a single, 8.0 MGD facility at Mankin's Crossing with a treatment level of 5/2/5;
- Scenario H, a two plant scenario that maintains the existing treatment plant at 2.5 MGD with an upgraded treatment level of 10/3/4. A large, 5.5 MGD plant would be built at Mankin's Crossing at a treatment level of 10/2/6;
- Scenario G1, a three plant scenario with the existing 2.5 MGD treatment plant, a 2.0 MGD plant at Berry Creek and a 3.5 MGD plant at Mankin's Crossing, all at a treatment level of 10/3/4;
- Scenario D1a2 is a four plant scenario with a 1.0 MGD plant at Dove Springs. The existing plant is maintained at 2.5 MGD, the Berry Creek plant is built at 2.0 MGD and the Mankin's Crossing plant has a maximum capacity of 2.5 MGD. All plants operate at a treatment level of 10/3/4;
- A two-stage scenario in which the existing plant is maintained at 2.5 MGD and temporary, 1.2 MGD package treatment plants are located at Berry Creek and Dove Springs. When the capacity of these two plants is exceeded, all of their flows will be diverted to a large, 5.5 MGD plant at Mankin's Crossing, resulting in a scenario resembling Scenario H.

VII.A.2 Modification of Existing Georgetown Treatment Plant Operation

VII.A.2.a TWC Mandated Effluent Limits

The TWC wasteload evaluation for Segment 1248, DRAFT March 16th, 1987 and not finalized, mandates that the City of Georgetown provide a treatment level of 10/3/4 at all discharges greater than 1.8 MGD for the summer season, May to September. The wasteload evaluation further stipulates that these additional treatment levels be in place by July 1, 1992. Therefore, the City of Georgetown is faced with a decision

within the next 3 years as to how they will comply with the pending TWC mandate. Modeling performed in evaluation of additional treatment plant sites and treatment levels demonstrated clearly that the City of Georgetown WWTP discharge levels are the key to maintaining DO concentrations above the State minimum criteria of 5 mg/L for Segment 1248 and dictate the treatment levels of all downstream WWTPs. The City of Georgetown currently discharges an average of 1.7 MGD of treated effluent to the San Gabriel River. Therefore, the City's decision as to how to comply with the TWC's wasteload evaluation must be made in the very near future.

VII.A.2.b Compliance Options

There are three obvious options that can be pursued by the City in order to comply with the TWC discharge limit requirements:

- The City can upgrade the existing WWTP to provide nitrification at the current design flow of 2.5 MGD. This upgrade would require the installation of additional aeration basins and air supply capacity, in order to provide the additional hydraulic retention times and increased air required for complete nitrification. It is estimated that this upgrade would cost approximately \$1.3 million. If the City decides to pursue this option, design on the upgrade for the treatment plant must begin immediately.
- The City may unload the existing facility to a capacity level not exceeding an average daily flow of 1.8 MGD and continue normal operation. Since nitrification is not required by the TWC wasteload evaluation at flows less than 1.8 MGD, there will be no additional costs incurred at the treatment plant. However, there will be additional costs associated with the provision of treatment capacity, lift stations and interceptors to accommodate the additional flow at another facility, as well as the additional costs associated with higher treatment levels that would be necessary at downstream plants.
- The City can modify the existing facility operation at a reduced flow, in order to provide nitrification, and divert the additional flows to a new facility. The cost of this modification would be approximately the same as unloading the plant to less than 1.8 MGD and continuing normal operation. However, the modeling analysis indicates that there may be a cost saving resulting from lower required treatment levels at larger downstream plants.

VII.A.2.c Description of Existing Treatment Process

The existing Georgetown WWTP is a parallel stream contact stabilization process (Figure VII.1). The design capacity of the existing plant is 2.5 MGD with a peak 2 hour treatment capacity of 7.5 MGD. The efflu-

VII-3

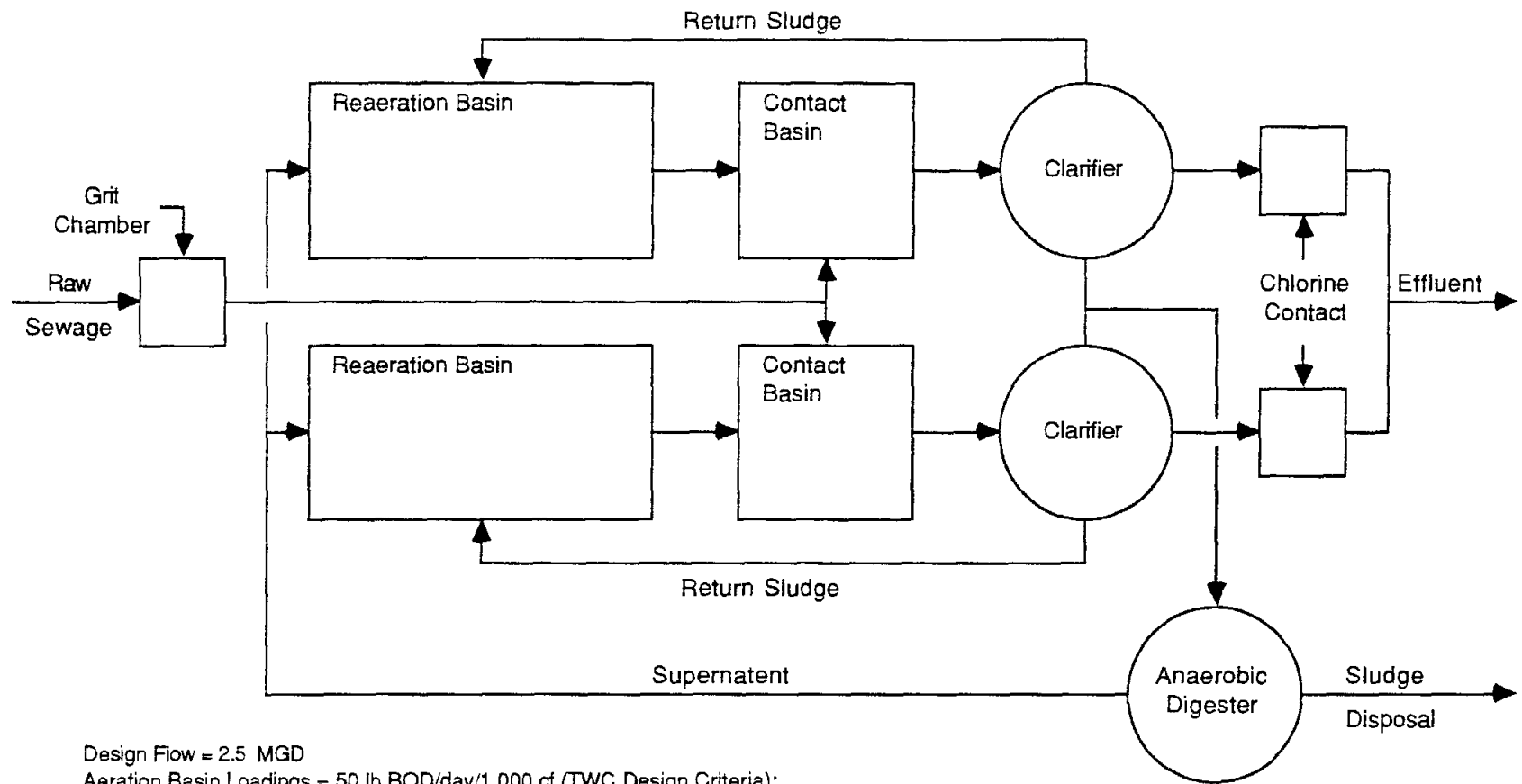

Design Flow = 2.5 MGD
Aeration Basin Loadings = 50 lb BOD/day/1,000 cf (TWC Design Criteria);
= 37.0 lb BOD/day/1,000 cf (actual);
Clarifier Loadings = 500 gpd/sf (TWC Design Criteria average); = 1,200 gpd/sf (TWC Design Criteria peak);
= 250 gpd/sf (actual average); = 665 gpd/sf (actual peak);
Weir Loadings = 30,000 gpd/ft (TWC Design Criteria peak);
= 8,100 gpd/ft (actual peak)

Figure VII.1
Flow Diagram of Existing Georgetown Wastewater Treatment Plant

ent limits currently prescribed in the TWC permit are 10 mg/L BOD₅, 15 mg/L NH₃ and 2 mg/L DO in the effluent. The contact stabilization process was developed to take advantage of the absorptive properties of activated sludge. Raw sewage, after passing through bar screens and an aerated grit chamber, enters an aerated contact basin where BOD is absorbed into the activated sludge. The residence time in the contact chamber is approximately 20-40 minutes. The sewage then passes through a clarifier, where the activated sludge with the absorbed BOD settles to the bottom and the relatively clear supernatant is removed at the top of the tanks. Some of the activated sludge at the bottom of the clarifier is transferred to an anaerobic digester, where the cellular material is broken down to facilitate separation of water from the sludge solids.

A portion of the sludge from the bottom of the clarifier is returned to the reaeration basin where, in the presence of oxygen for 3-6 hours, oxidation of the biochemical oxygen demanding organic material occurs. During this period the absorbed organics are utilized for the production of energy and new cells by the microorganisms in the activated sludge. The aeration volume requirements of the contact stabilization process are approximately 50 percent of those of a conventional activated sludge plant. The contact stabilization process has been found to work very well on domestic waste, needing a minimum aeration tank volume and no primary clarification. Thus, it is often the least cost alternative for domestic wastewater treatment and is particularly attractive to cities without large industrial dischargers.

VII.A.2.d Modification of Existing Treatment Process

Because of the short hydraulic retention aeration times, the contact stabilization process is not conducive to nitrification in a single stage process. Therefore, modification of the existing Georgetown WWTP operation to accomplish nitrification requires conversion of the split stream parallel process to a single stream, series two-stage process (Figure VII.2). Under the proposed modifications, the existing Georgetown plant would be unloaded to an average daily flow of 1.67 MGD. The TWC design criteria for sewage systems requires that the maximum aeration basin loading be less than or equal to 50 pounds of BOD₅ per day per thousand cubic feet of aeration capacity (lb BOD₅/day/1,000 ft³). Because the existing Georgetown facility was somewhat over-designed to accommodate future expansion, 1.67 MGD can be accommodated in a series operation with an aeration basin loading of approximately 49.4 lb BOD₅/day/1,000 ft³ of aeration capacity in the first stage, thereby complying with the TWC design criteria.

Carbonaceous BOD destruction would be accomplished primarily in the first stage. After first stage aeration, the effluent would pass to the second stage aeration basin, where it would be metabolized by primary nitrification bacteria, Nitrosomonas and Nitrobacter. Destruction of nitrogenous BOD would be completed in this second stage, where some additional destruction of carbonaceous BOD would also occur. Table VII.1 compares the City of Georgetown WWTP with the TWC design criteria under existing

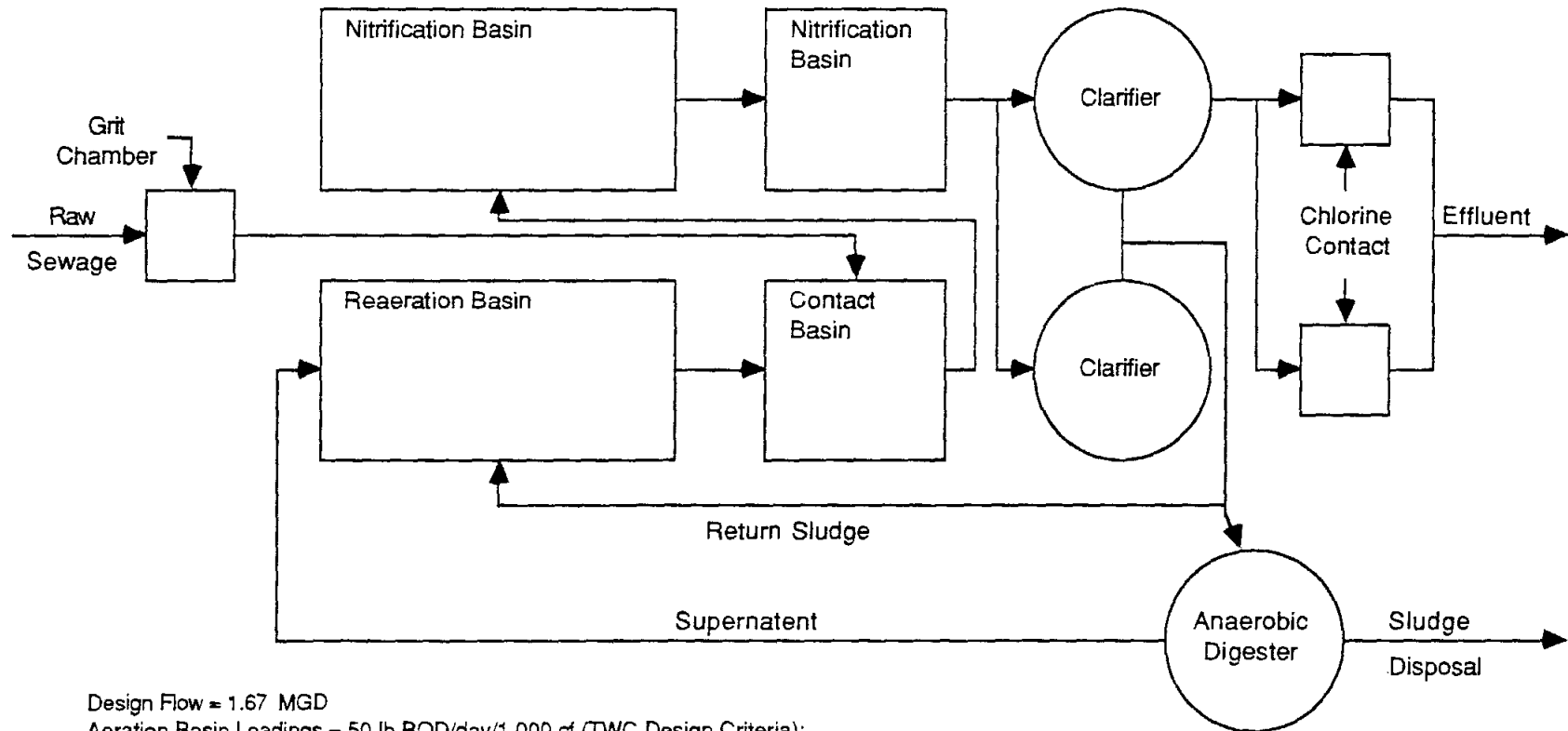

Design Flow = 1.67 MGD

Aeration Basin Loadings = 50 lb BOD/day/1,000 cf (TWC Design Criteria);
 = 49.4 lb BOD/day/1,000 cf (actual 1st stage);
 = 8.5 lb BOD/day/1,000 cf (estimated 2nd stage);

Clarifier Loadings = 500 gpd/sf (TWC Design Criteria average 1st stage); = 1,200 gpd/sf (TWC Design Criteria peak 1st stage);
 = 400 gpd/sf (TWC Design Criteria average 2nd stage); = 1,000 gpd/sf (TWC Design Criteria peak 2nd stage);
 = 333 gpd/sf (actual average 1st and 2nd stages); 890 gpd/sf (actual peak 1st and 2nd stages);

Weir Loadings = 30,000 gpd/ft (TWC Design Criteria peak);

= 17,200 gpd/ft (estimated peak 1st and 2nd stages)

Figure VII.2
 Flow Diagram of Modified Existing Georgetown Wastewater Treatment Plant

and proposed operational conditions. The existing facility is described, together with the proposed modifications, and both operational conditions are compared with the numerical design criteria prescribed by the TWC. The modified operation complies with all of the numerical criteria prescribed by the TWC for the contact stabilization process and the nitrification process.

Costs associated with this operational change should be small. The original design of the facility allowed each of the parallel streams to accommodate 75 percent of the design flow (1.875 MGD). Therefore, the piping associated with these operations was commensurately sized. In addition, parallel designs allow the flexibility of transfer of wastewater among treatment units; therefore, the majority of the piping necessary to accomplish this operational change should already be in place.

The motivation for enacting this operational change is that the treatment levels and treatment capacities of downstream facilities are greatly impacted by the properties of the Georgetown effluent. By providing nitrification at the existing Georgetown facility, the DO sag curve downstream of the outfall will be minimized and at the point of discharge of either the Berry Creek or Mankin's Crossing facility the DO levels will recover sufficiently to allow larger quantities of discharge at the 10/3/4 treatment level, while meeting the 5 mg/L minimum DO standard for the San Gabriel River Segment 1248. This operational change does not, however, permanently relieve the City of Georgetown of the obligation to upgrade the existing WWTP. Population and flow projections for the basins that will contribute to this facility indicate that by the year 2030, flows to the plant will average approximately 2.5 MGD. This modification does, however, postpone until some future date the capital expenditure necessary to provide additional nitrification capacity to the 2.5 MGD plant.

VII.B Methodology

VII.B.1 Determining Wasteload at each Site

VII.B.1.a Service Area Delineation

The service area served by each plant under each scenario is shown in Figures VII.3 - VII.6. In general, the service area boundaries are drawn along major ridge lines in order to provide maximum benefit from the available gravity flow within the overall area. The result is a consolidation of various combinations of the drainage areas described in Section III.A.

Drainage areas are labeled either numerically or alphabetically. The numeric basins represent areas currently served with sewers or additions to major interceptors in adjacent basins. The alphabetically labeled basins represent areas not currently serviced with majors interceptors, but rather septic tanks or nothing at

Table VII.1
Comparison City of Georgetown Wastewater Treatment Facility With TWC Design Criteria
Under Existing and Proposed Operational Conditions a/ b/

Unit	Description of Existing Facilities c/	Description of Modified Facilities d/	TWC Design Criteria Contact Stabilization	Existing Design	TWC Design Criteria Cont. Stab. w. Nitrification	Modified Design
Headworks						
Bar Screens	One mechanically cleaned bar screen; and one manually cleaned bar screen.	Unmodified	7.5 MGD each	8.0 MGD each	7.5 MGD each	4.5 MGD total
Raw Water Lift Station	Drypit-wetpit with 5 constant speed sewage pumps, one 700 gpm, two 1,300 gpm, and two 2,600 gpm; rated firm capacity is 5,900 gpm	Unmodified	7.5 MGD total	8.5 MGD total	7.5 MGD total	4.5 MGD total
Grit Chamber	Two aerated grit Chambers with 442 total sq. ft. length	Unmodified	Hydraulic retention time of 5 minutes @ 7.5 MGD	Hydraulic retention time of 5 minutes @ 9.2 MGD	Hydraulic retention time of 5 minutes @ 4.5 MGD	Hydraulic retention time of 10.2 minutes @ 4.5 MGD
Aeration Basins						
Space Loadings	Two Rectangular Basins with total volume of 141,670 cf operated in parallel with two-thirds reaeration and one-third contact volume	Two Rectangular Basins with total volume of 141,670 cf operated in series with intermediate clarification between stage; each stage with two-thirds reaeration and one-third contact volume	50 lb/BOD/day/1,000 cf @ 2.5 MGD	37 lb/BOD/day/1,000 cf @ 2.5 MGD	50 lb/BOD/day/1,000 cf @ 1.67 MGD	49 lb/BOD/day/1,000 cf @ 1.67 MGD
Air Supply	Four cent. blowers: two 4,200 scfm; two 4,200 scfm; two 2,100 scfm; total capacity 12,600 scfm @ 7 psi	Four cent. blowers: two 4,200 scfm; two 4,200 scfm; two 2,100 scfm; total capacity 12,600 scfm @ 7 psi	1.0 scfm/lb BOD5/day	2.4 scfm/lb BOD5/day	1.0 scfm/lb BOD5/day	First stage = 3.6 scfm/lb BOD5/day second stage = 10.0 scfm/lb BOD5/day & 9.2 scfm/lb NH3/day
Sedimentation						
Clarifiers	Two circular 85 ft diameter operated as parallel streams with an effective total surface area of 10,044 sq. ft., effective total volume of 120,528 cf, and a weir length of 412 ft.	Two circular 85 ft diameter operated as part of a series stream with an effective total surface area of 10,044 sq. ft., effective total volume of 120,528 cf, and a weir length of 412 ft.	500 gpd/sf/day (average) 1,200 gpd/sf/day (peak) 30,000 gpd/ft weir (max.)	250 gpd/sf/day (average) 665 gpd/sf/day (peak) 8,100 gpd/ft weir (max.)	400 gpd/sf/day (average) 1,000 gpd/sf/day (peak) 30,000 gpd/ft weir (max.)	333 gpd/sf/day (average) 890 gpd/sf/day (peak) 17,200 gpd/ft weir (max.)
Sludge Handling						
Digester	One aerobic digester with 27 day SRT and 61,172 cf total volume; coarse bubble	Unmodified	30 scfm/1,000 cf Minimum SRT of 15 days; 10 cf vol./lb BOD5/day		30 scfm/1,000 cf Minimum SRT of 15 days; 10 cf vol./lb BOD5/day	
Sludge Drying Beds	Open Beds with a total area of 53,600 sq. ft.	Unmodified	1.0 sf/capita	2.13 sf/capita	1.0 sf/capita	3.18 sf/capita
Chlorination						
Chlorine Contact Chamber	Two basins with a total volume of 105,000 gal.	Unmodified	20 minute detention time @ 7.5 MGD	20 minute detention time @ 7.6 MGD	20 minute detention time @ 4.5 MGD	33 minute detention time @ 4.5 MGD

a/ The existing Georgetown wastewater facility will be unloaded from its current design capacity of 2.5 MGD (7.5 MGD peak) to 1.67 MGD (4.5 MGD peak) through construction of new interceptor lines and lift stations that will redirect wastewater from the southern portion of the City (basins 0, 3a, and 3b) to the proposed Mankin's Crossing facility.

b/ TWC Design Criteria for Sewerage Systems are found in Texas Administrative Code (TAC) Title 31 §§317.1-317.13 (printed 6/27/88).

c/ Source: "City of Georgetown, Texas Wastewater Treatment Plant Site Study", prepared by Freese and Nichols, Inc. July, 1987.

d/ The existing parallel stream contact-stabilization treatment system (Q design = 2.5 MGD) will be converted to a two stage series contact-stabilization system (Q design = 1.67 MGD). Carbonaceous BOD reduction will be accomplished in the first stage; nitrogenous BOD reduction (nitrification) will be accomplished in the second stage.

and proposed operational conditions. The existing facility is described, together with the proposed modifications, and both operational conditions are compared with the numerical design criteria prescribed by the TWC. The modified operation complies with all of the numerical criteria prescribed by the TWC for the contact stabilization process and the nitrification process.

Costs associated with this operational change should be small. The original design of the facility allowed each of the parallel streams to accommodate 75 percent of the design flow (1.875 MGD). Therefore, the piping associated with these operations was commensurately sized. In addition, parallel designs allow the flexibility of transfer of wastewater among treatment units; therefore, the majority of the piping necessary to accomplish this operational change should already be in place.

The motivation for enacting this operational change is that the treatment levels and treatment capacities of downstream facilities are greatly impacted by the properties of the Georgetown effluent. By providing nitrification at the existing Georgetown facility, the DO sag curve downstream of the outfall will be minimized and at the point of discharge of either the Berry Creek or Mankin's Crossing facility the DO levels will recover sufficiently to allow larger quantities of discharge at the 10/3/4 treatment level, while meeting the 5 mg/L minimum DO standard for the San Gabriel River Segment 1248. This operational change does not, however, permanently relieve the City of Georgetown of the obligation to upgrade the existing WWTP. Population and flow projections for the basins that will contribute to this facility indicate that by the year 2030, flows to the plant will average approximately 2.5 MGD. This modification does, however, postpone until some future date the capital expenditure necessary to provide additional nitrification capacity to the 2.5 MGD plant.

VII.B Methodology

VII.B.1 Determining Wasteload at each Site

VII.B.1.a Service Area Delineation

The service area served by each plant under each scenario is shown in Figures VII.3 - VII.6. In general, the service area boundaries are drawn along major ridge lines in order to provide maximum benefit from the available gravity flow within the overall area. The result is a consolidation of various combinations of the drainage areas described in Section III.A.

Drainage areas are labeled either numerically or alphabetically. The numeric basins represent areas currently served with sewers or additions to major interceptors in adjacent basins. The alphabetically labeled basins represent areas not currently serviced with majors interceptors, but rather septic tanks or nothing at

GEORGETOWN REGIONAL
WASTEWATER PLANNING
STUDY

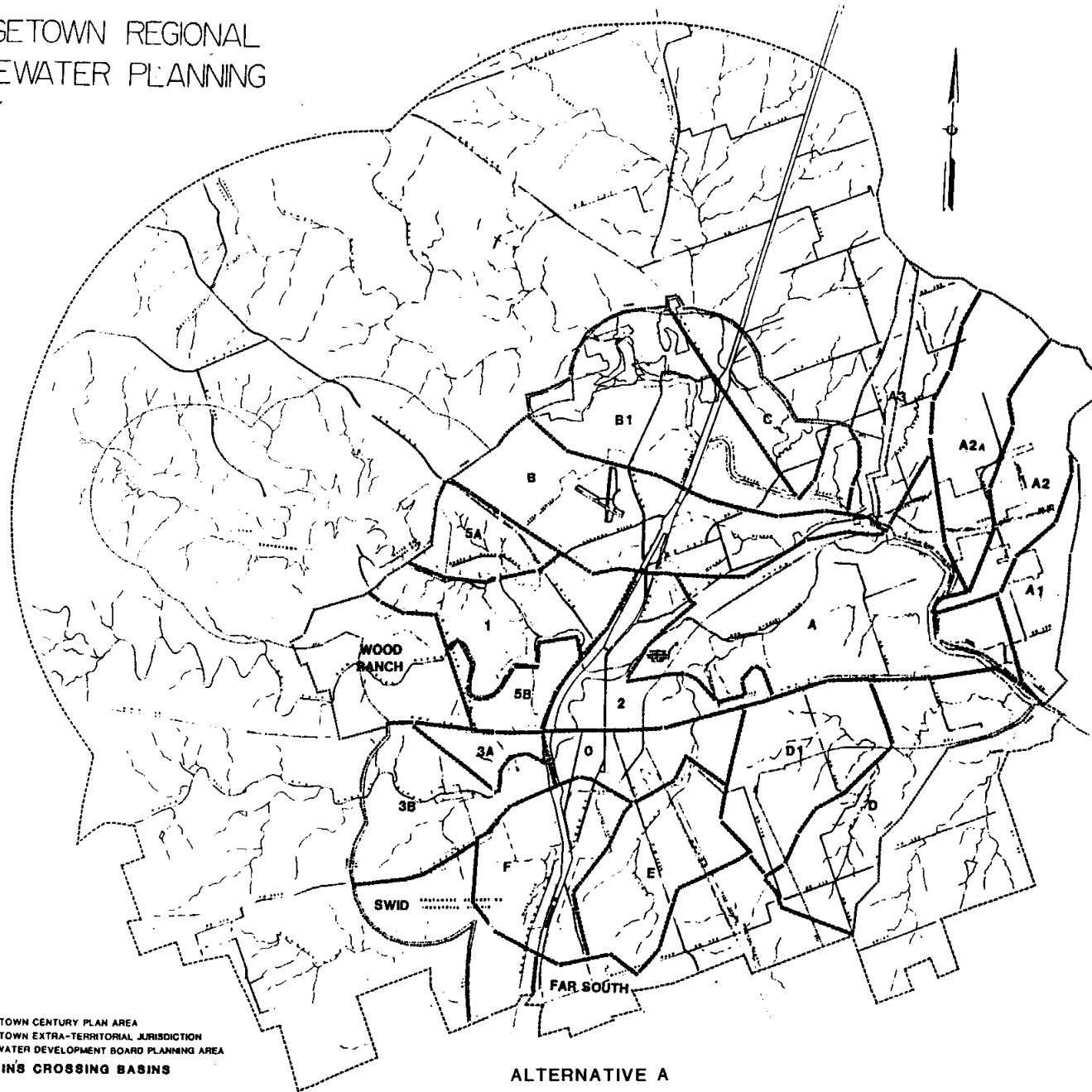

- LEGEND**
- GEORGETOWN CENTURY PLAN AREA
 - GEORGETOWN EXTRA-TERRITORIAL JURISDICTION
 - TEXAS WATER DEVELOPMENT BOARD PLANNING AREA
 - MANKIN'S CROSSING BASINS

ALTERNATIVE A

FIGURE VII.3

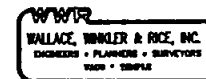

GEORGETOWN REGIONAL
WASTEWATER PLANNING
STUDY

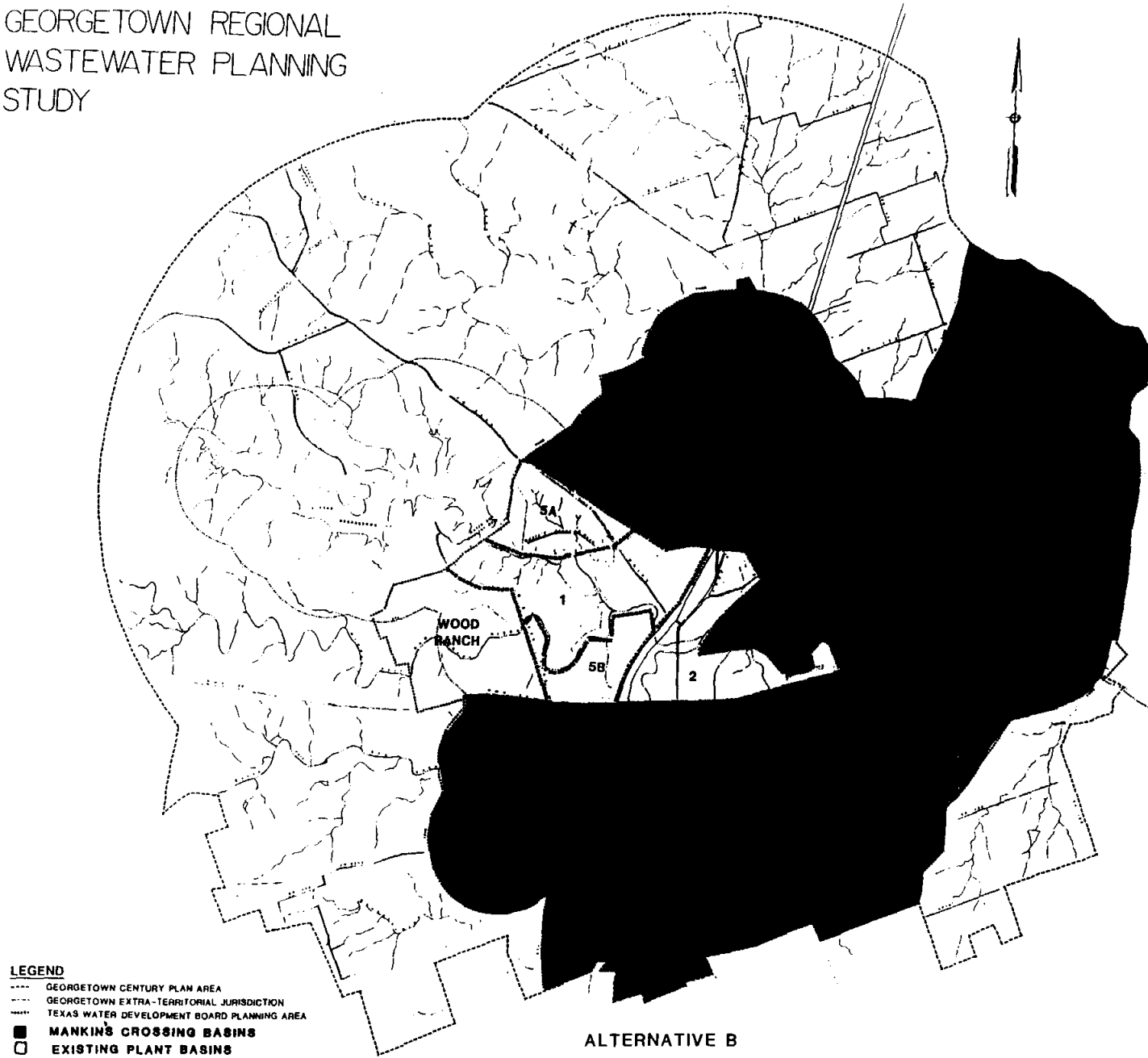

FIGURE VII.4

WWR
WALLACE, WINKLER & RICE, INC.
ENGINEERS • PLANNERS • SURVEYORS
1925 • TEXAS

GEORGETOWN REGIONAL
WASTEWATER PLANNING
STUDY

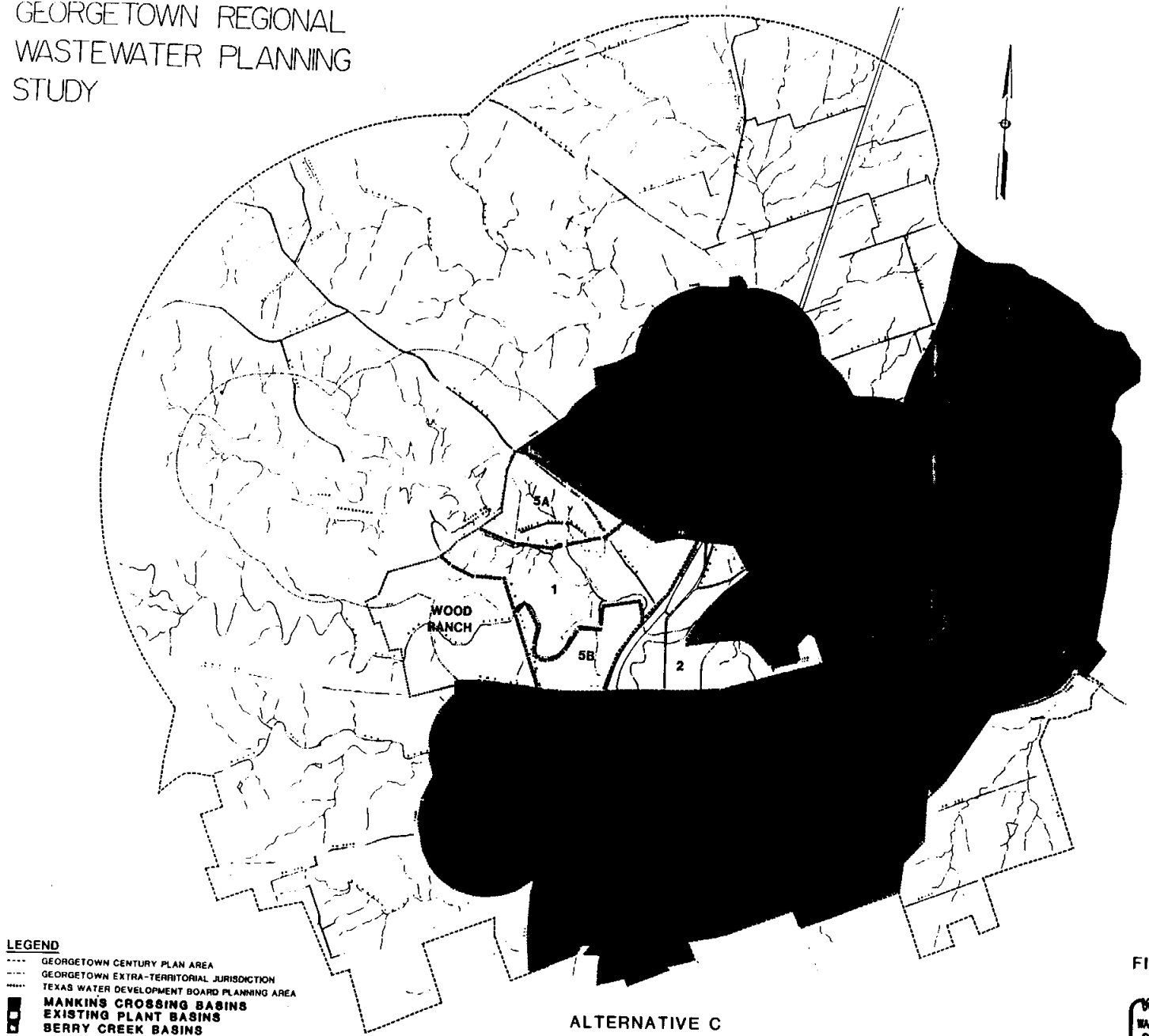
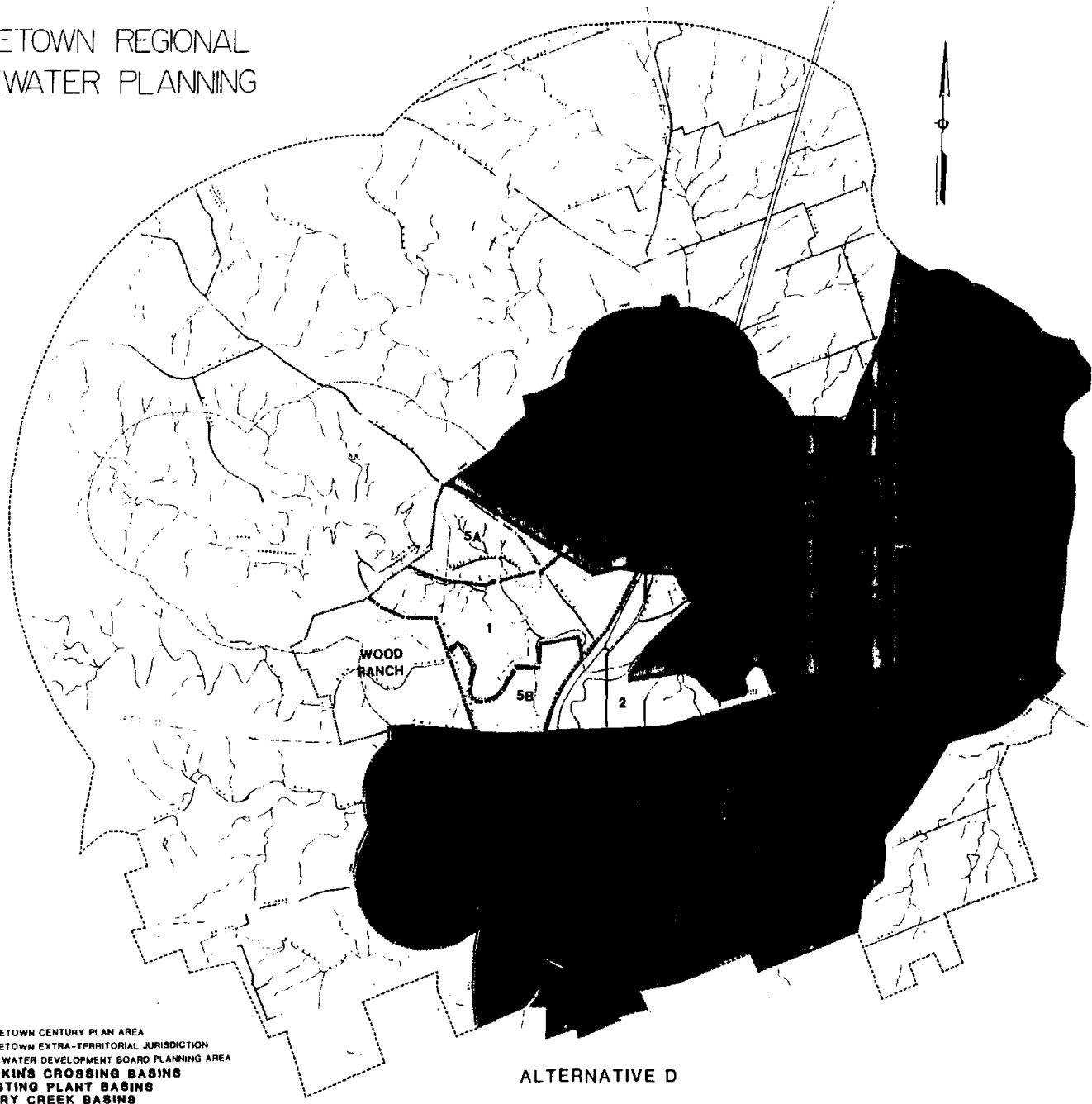

FIGURE VII.5

WWR
WALLACE, WINKLER & RICE, INC.
ENGINEERS • PLANNERS • SURVEYORS
SINCE 1916

GEORGETOWN REGIONAL
WASTEWATER PLANNING
STUDY



- LEGEND**
- GEORGETOWN CENTURY PLAN AREA
 - GEORGETOWN EXTRA-TERRITORIAL JURISDICTION
 - TEXAS WATER DEVELOPMENT BOARD PLANNING AREA
 - MANKIN'S CROSSING BASINS
 - EXISTING PLANT BASINS
 - BERRY CREEK BASINS
 - LAKE CROCKET BASIN

ALTERNATIVE D

FIGURE VII.6

WWR
WALLACE, WINKLER & RICE, INC.
 ENGINEERS • PLANNERS • SURVEYORS
 1929 • 1974

all. Three areas, the Southwestern Industrial District, Wood Ranch and the Far South, do not conform to the above criteria and are named more by description than by any level of service.

For the numeric basins, consideration was given to the RVI study boundary, called the urban area, which was to be completed before submission of this report. With no applicable final data at this time, the major interceptors were reviewed for 2030 flows and sized accordingly, giving due credit to the existing lines whenever possible.

For basins 3a, 3b, 5a, and 5b, the forks of the San Gabriel River are boundaries which divide the entire basin into smaller sub-basins. As stated previously, these lines are additions to the City of Georgetown's existing interceptors, called 3 and 5 in previous studies performed by Freese & Nichols.

VII.B.1.b Wasteload Projections

As described in Section III.C, wasteload projections were based on a combination of residential and commercial flows. Residential flows were computed from population projections at 110 gal/cap/day. The Land Use Intensity Map was used to determine the number of acres for commercial land use in each drainage area. Richardson-Verdoorne, Inc. (RVI) assigned each intensity of land use a value for wastewater production, expressed as gallons per acre per day. These values were used to calculate the average daily commercial wastewater flow in the designated basin.

Using the wasteload projections for each drainage area shown in Table VII.2, wasteload projections for each service area were predicted for the years 1990, 2000, 2010, 2020 and 2030. For each treatment plant in each scenario the same calculations were done assuming that water conservation measures would result in a 15 percent reduction in wastewater generation. These data are shown in tabular form accompanying the description for each scenario.

The wastewater flow projections at each site were then used to determine the optimum construction schedule for each plant. As a rule, WWTPs are designed for future expansion as replicate images of the first construction phase. Also, the phasing of capacity increases at any one site should be between 10 and 20 years, in order to take advantage of economies of scale without overbuilding.

Because interceptors are not readily replaced to accommodate increased capacity, the major interceptors were sized based on peak flows expected in the year 2030. Average flow, shown in Table VII.2, is the average daily flow that would occur during the month of maximum flow. Peak flow is the maximum flow expected in any two-hour period. The peaking factors used for each basin range from 2.5 to 4, based on basin size, interceptor length and magnitude of flow. Larger basins, longer lines and larger average flows were assigned lower values.

Table VII.2
 Georgetown Regional Wastewater Planning Study
 Wastewater Flow Projections for a Single Georgetown
 Regional Facility at Mankin's Crossing

Basin	Description	Projected Wastewater Flow (MGD)				
		1990	2000	2010	2020	2030
0	Downtown (south)	0.378	0.568	0.825	0.916	1.132
1	North Fork San Gabriel	0.339	0.456	0.666	0.794	0.962
2	Downtown (north)	0.334	0.410	0.610	0.743	1.149
3a	South Fork San Gabriel	0.000	0.031	0.050	0.063	0.082
3b	South Fork San Gabriel	0.138	0.203	0.289	0.394	0.499
5a	Booty's Crossing	0.033	0.076	0.120	0.210	0.278
5b	Middle Fork San Gabriel	0.032	0.046	0.082	0.102	0.161
A	San Gabriel	0.039	0.070	0.126	0.162	0.220
B	Pecan Branch	0.178	0.266	0.362	0.471	0.626
B1	Berry Creek	0.219	0.326	0.514	0.623	0.828
C	Dry Berry Creek	0.010	0.025	0.038	0.050	0.065
D	Mankin's Branch	0.000	0.017	0.030	0.045	0.060
D1	North Mankin's Branch	0.014	0.021	0.036	0.049	0.075
E	Smith's Branch	0.033	0.069	0.145	0.304	0.460
F	I- 35 South	0.076	0.148	0.284	0.373	0.483
W.R.	Wood Ranch	0.015	0.020	0.025	0.035	0.041
SWID	Industrial District	0.100	0.175	0.230	0.300	0.353
F.S.	Westinghouse Road	0.075	0.100	0.150	0.195	0.230
A1	East Weir	0.004	0.007	0.010	0.013	0.017
A2	Middle Weir	0.010	0.015	0.020	0.025	0.035
A2a	West Weir	0.009	0.015	0.020	0.026	0.034
A3	East Fork San Gabriel	0.012	0.020	0.025	0.035	0.045
		2.048	3.084	4.657	5.928	7.835

For each scenario the average and peak flows used to determine the size of each interceptor are presented, together with the source of the flows (population base or contributing interceptor). Where flows are cumulative, a prime (') designation is used to show that sizing is based on cumulative flows rather than on the flow per basin used elsewhere.

VII.B.2 Evaluation and Sizing of Collection Systems

VII.B.2.a Gravity Sewers

In order to utilize existing topographical conditions and to reduce operation and maintenance costs, gravity sewer collection lines were used wherever possible. Gravity lines are normally used if sufficient slope is available to provide the correct flow characteristics for the projected flows.

In some instances the slope required to attain these characteristics is achieved through deep installation. Occasionally, no actual capital cost savings over pressurized lines is realized because of the depth required to obtain the correct line slopes.

VII.B.2.b Force Mains/Lift Stations

Force mains are normally required to convey flows from lift stations to the required point of delivery. In general, they are much smaller than gravity lines and are installed at shallow depths. Therefore, the cost of a force main can often be approximately the same or less than the cost of a gravity line. The only significant difference in cost between a lift station and a force main lies in the capital expenditure and operation and maintenance costs, which can average as much as \$75/day per lift station. This difference is due to increased energy consumption and equipment maintenance of lift stations.

VII.B.2.c Sizing of Lines

Sanitary sewers are designed as open channels, with wastewater flowing downstream in the pipe under the force of gravity. Assuming a uniform, steady, open channel flow. Manning's equation applies:

$$Q = \frac{1.49}{n} A R^{2/3} S^{1/2} \quad \text{[VII-1]}$$

- where: Q = quantity of flow in cubic feet per second
n = coefficient of roughness (commonly adopted value for sewer design is 0.013)
A = cross-sectional area of flow in square feet
S = slope of the hydraulic gradient in feet per foot
R = hydraulic radius in feet (cross-sectional area divided by the wetted perimeter)

Assuming a hydraulic grade and calculating the design flows as described above, the line is sized accordingly using Manning's equation and solving for the diameter (D):

$$D = \left(2.16 Q \frac{N}{S^{1/2}} \right)^{3/8} \quad \text{[VII-2]}$$

The hydraulic gradient slopes for the proposed lines were calculated based on topographic information taken from U.S. Geological Survey maps. For calculation purposes, the pipes were assumed to be flowing full with Manning's n value equal to 0.013.

VII.B.3 Estimating Capital Costs

VII.B.3.a Wastewater Treatment Plants

The capital costs of building the WWTPs were calculated using the data shown in Figure VII.7. Because costs do not increase as a linear function of plant size, empirical data were used to construct cost estimates. It is evident that a linear relationship exists between logarithmic increases in plant size and logarithmic increases in costs. Different cost curves are also obtained for different treatment levels.

The capital costs derived from Figure VII.7 are based on 1986 data. For the purposes of this report, 4 percent inflation has been used to adjust the figures to 1990 dollars. In addition to the capital cost of constructing each WWTP, the following estimates have been included:

- engineering fees based on ASCE General Engineering Service Fee Curves;
- land costs based on \$5,000 per acre;
- surveying and staking fees based on 3 percent of construction costs;
- legal and administrative fees based on 2.5 percent of construction costs;
- permitting expenses and other fees based on 2 percent of construction costs;
- contingencies based on 10 percent of construction costs.

Based on these assumptions, estimates were derived for each phase of each project in 1990 dollars. These data were tabulated for each scenario. Assuming an interest rate of 10 percent and a pay-out period of 25 years, the capital costs were converted to annual costs. Assuming an annual discount rate of 5 percent, the costs incurred in each year for each scenario were then converted to 1990 dollars. The

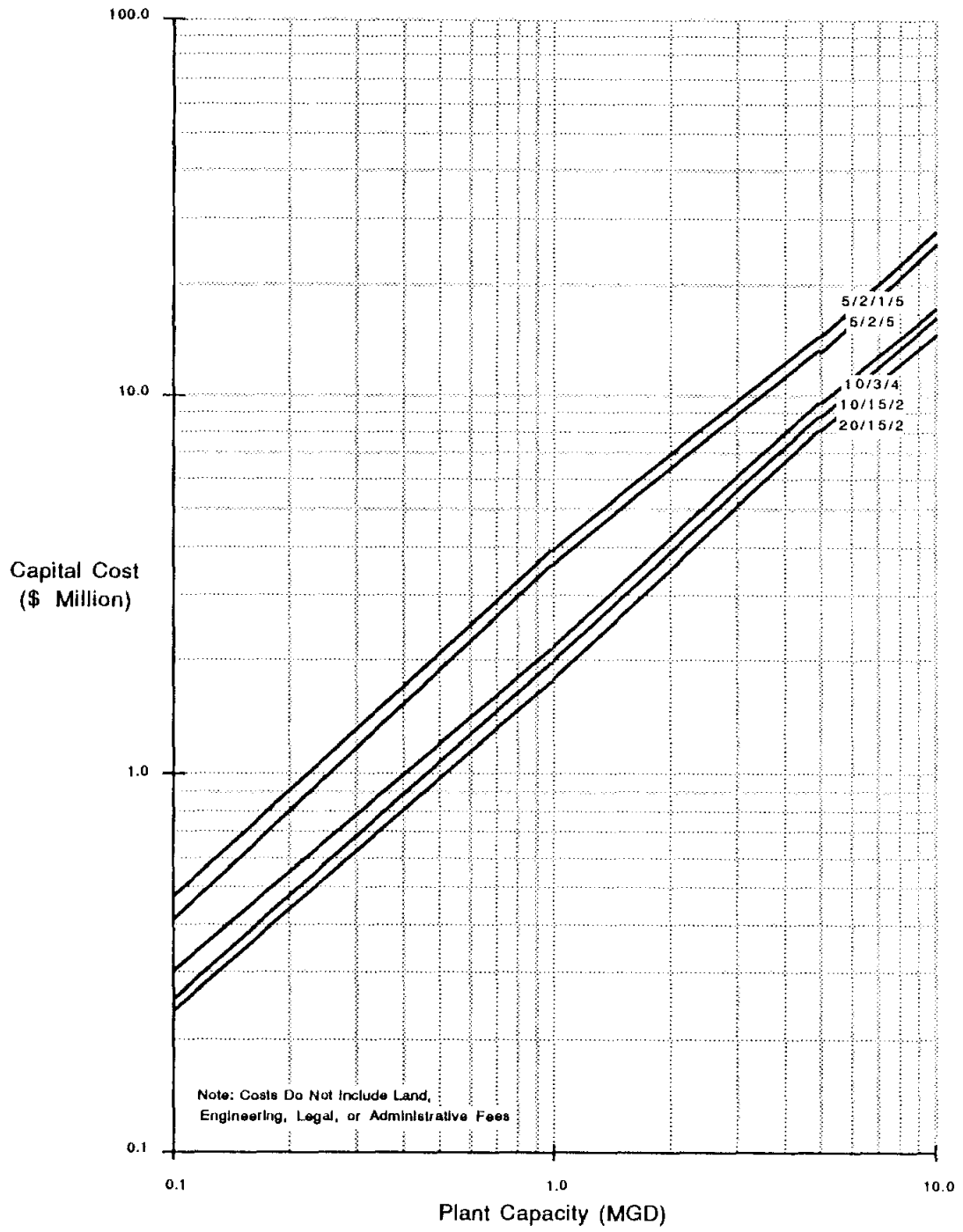

Figure VII.7
 Capital Cost of Treatment Capacity for
 Different Levels of Treatment

graphs show the cumulative costs incurred for each scenario for the total pay-out period, which extends to 2050 in most cases.

VII.B.3.b Collection System

A complete interceptor system for each scenario has been outlined. Wherever possible, the lines follow the existing interceptor layout. However, it is assumed that, because of the age of many of these lines, all of them will have to be replaced within the planning horizon. No attempt has been made to determine when the construction costs for each of these interceptors will be incurred.

The capital cost, by interceptor, for construction of the wastewater collection systems include:

- capital expenditures for lift stations and line excavation cut to a maximum depth of 8 feet and lined with a trench safety system;
- manholes located every 250 feet (4 feet diameter manholes for pipe diameters less than 21 inches and 6 feet for pipe diameters 21 inches or greater).

Cost do not include operation and maintenance or power.

As in the case of the cost estimates for the WWTPs, the total cost of each collection system was amortized over 25 years at a 10 percent annual rate of interest, discounted at 5 percent per year to 1990 dollars. However, because no attempt was made to determine when each interceptor would be constructed (or replaced), construction costs reflect those that would be incurred if all of the lines were built in 1990. This has the effect of inflating the cost estimates as compared with the WWTPs.

VII.C Results

VII.C.1 One Plant Scenario

VII.C.1.a Wastewater Treatment Plants

Phasing of Facility Construction

Figure VII.8 shows the total daily wastewater generation predicted for the Georgetown area until 2030, using the data shown in Table VII.2. It is anticipated that growth in the service area would increase from 2.1 MGD in 1990 to 7.8 MGD in 2030. Also shown are the predicted results if a rigorous water conservation program were implemented. Assuming a 15 percent reduction in wastewater generation, the total flows in 2030 would be reduced to 6.7 MGD (Table VII.3 and Figure VII.8).

Table VII.3
 Georgetown Regional Wastewater Planning Study
 Wastewater Flow Projections for a Single Georgetown
 Regional Facility at Mankin's Crossing With 15% Water Conservation

Basin	Description	Projected Wastewater Flow (MGD)				
		1990	2000	2010	2020	2030
0	Downtown (south)	0.321	0.483	0.701	0.779	0.962
1	North Fork San Gabriel	0.288	0.388	0.566	0.675	0.818
2	Downtown (north)	0.284	0.349	0.519	0.632	0.977
3a	South Fork San Gabriel	0.000	0.026	0.043	0.054	0.070
3b	South Fork San Gabriel	0.117	0.173	0.246	0.335	0.424
5a	Booty's Crossing	0.028	0.065	0.102	0.179	0.236
5b	Middle Fork San Gabriel	0.027	0.039	0.070	0.087	0.137
A	San Gabriel	0.033	0.060	0.107	0.138	0.187
B	Pecan Branch	0.151	0.226	0.308	0.400	0.532
B1	Berry Creek	0.186	0.277	0.437	0.530	0.704
C	Dry Berry Creek	0.009	0.021	0.032	0.043	0.055
D	Mankin's Branch	0.000	0.014	0.026	0.038	0.051
D1	North Mankin's Branch	0.012	0.018	0.031	0.042	0.064
E	Smith's Branch	0.028	0.059	0.123	0.258	0.391
F	I - 35 South	0.065	0.126	0.241	0.317	0.411
W.R.	Wood Ranch	0.013	0.017	0.021	0.030	0.035
SWID	Industrial District	0.085	0.149	0.196	0.255	0.300
F.S.	Westinghouse Road	0.064	0.085	0.128	0.166	0.196
A1	East Weir	0.003	0.006	0.009	0.011	0.014
A2	Middle Weir	0.009	0.013	0.017	0.022	0.030
A2a	West Weir	0.008	0.013	0.017	0.022	0.029
A3	East Fork San Gabriel	0.010	0.017	0.021	0.030	0.038
		1.741	2.624	3.961	5.043	6.660

In the single treatment plant scenario, all of this flow would be accommodated by one large treatment facility at Mankin's Crossing. The existing Georgetown treatment plant would be abandoned. Figure VII.9 shows a possible construction scenario that results in a total treatment capacity at Mankin's Crossing of 8 MGD by the year 2030. Construction would take place in three phases, starting with a 4 MGD plant in 1990. Table VII.2 shows that a plant of this size would accommodate all of the predicted growth in the study area until 2010. At this time, additional capacity would be required. The addition of another 2 MGD of capacity would extend the life of the plant until 2020. At that time another 2 MGD would be needed to fulfill the requirements of the planning period.

In Table VII.3 and Figure VII.10, similar estimates are made for wasteload predictions under conditions of 15 percent water conservation. An initial 3 MGD plant would be adequate until the year 2005. The addition of another 2 MGD of capacity at this time would extend the life of the plant until 2020. In 2020 another 2 MGD of additional capacity would be required to meet the demands predicted for 2030.

Cost Estimates

Table VII.4 shows the cost estimates for a single plant at Mankin's Crossing with and without water conservation. Based on the water quality modeling data, a higher, 5/2/5 treatment level is necessary. From the data in Figure VII.7, a 4 MGD plant at this treatment level would cost \$14.66 million for a total cost of \$18.26 million. With water conservation, a 3 MGD plant is proposed at a total cost of \$14.17 million. Each 2 MGD increase in capacity would cost \$7.97 million for a total cost (in 1990 dollars) of \$9.92 million.

These capital costs were then amortized over 25 years at 10 percent interest. A 5 percent discount rate was then applied to each annual payment and the cumulative costs determined. These estimates are shown in Figure VII.11. The result is a total cost of \$39.60 million without water conservation and \$34.63 with conservation.

VII.C.1.b Wastewater Collection Systems

With one plant located at Mankin's Crossing, the majority of the collection system will depend on gravity flow. Highway 29 represents the division of flows coming in from the north and south, with the exclusion of basin 0 which flows by gravity toward the existing plant, north of Highway 29 (see Figure VII.12 and Table VII.5).

Contributing Flows South of Highway 29

Since 1985, basins 3a and 3b have been diverted to the Smith Branch interceptor, F', and will continue under all scenarios. As the Southwestern Industrial District develops, force mains to basins 3b and F will

Figure VII.9
Georgetown Regional Wastewater Planning Study
Possible Build-out Demand and Capacity Relationship for
a Single Georgetown Regional Facility at Mankin's Crossing

VII-21

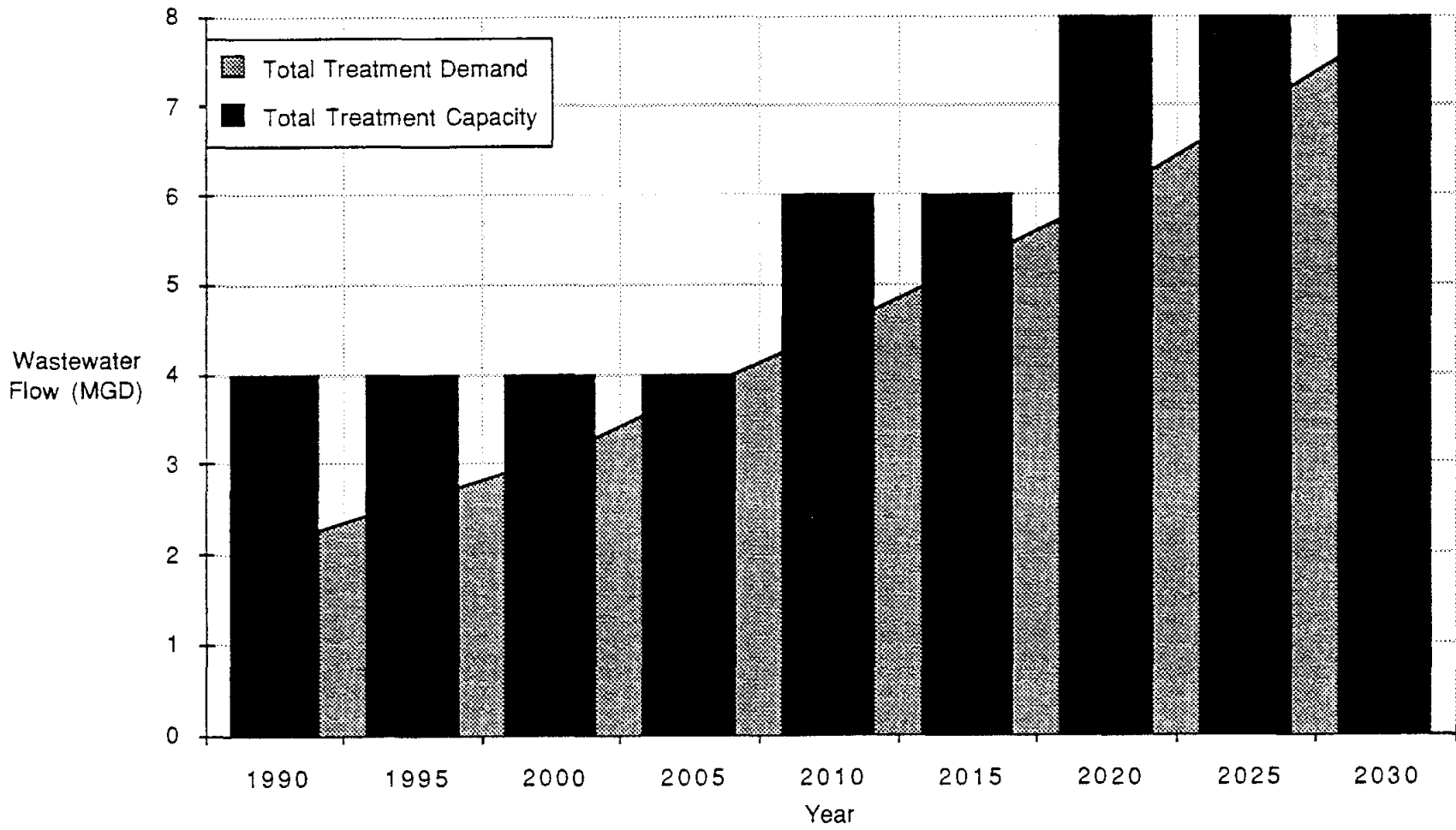
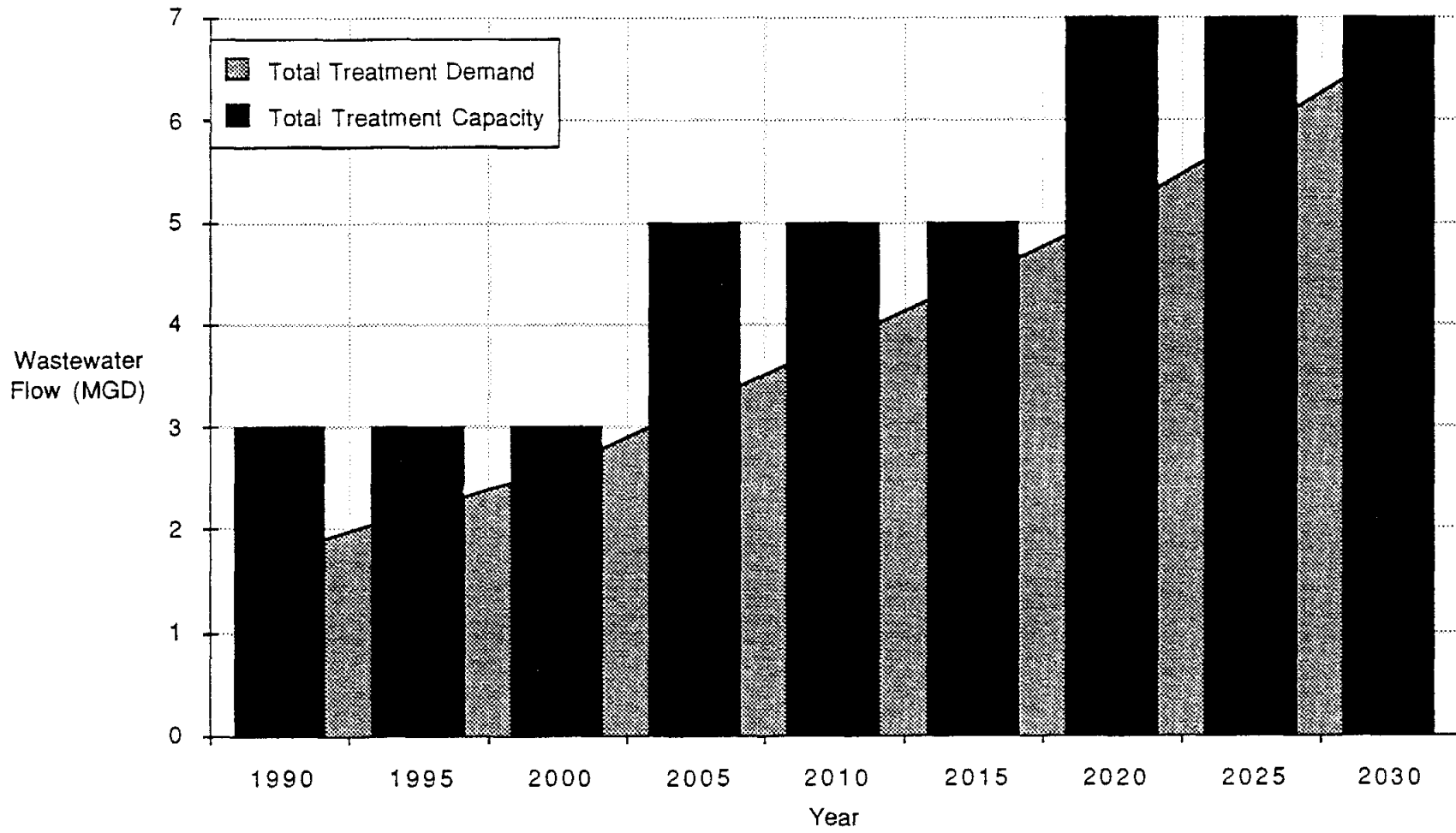

Figure VII.10
 Georgetown Regional Wastewater Planning Study
 Possible Build-out Demand and Capacity Relationship for a Single
 Georgetown Regional Facility at Mankin's Crossing With 15% Water Conservation



VII-22

Table VII.4
 Estimated Cost of Single Regional Facility at Mankin's Crossing
 With and Without Water Conservation (1990 Through 2030) a/

Proposed Mankin's Crossing Facility Without Water Conservation:

Function	Total Cost (\$ Million)								
	1990	1995	2000	2005	2010	2015	2020	2025	2030
1. Construction Cost b/	14.662				7.966		7.966		
2. Engineering c/	1.026				0.558		0.558		
3. Land d/	0.001				0.000		0.000		
4. Surveying and Staking e/	0.440				0.239		0.239		
5. Legal and Administration f/	0.367				0.199		0.199		
6. Permitting and Fees g/	0.293				0.159		0.159		
7. Contingencies h/	1.466				0.797		0.797		
Total	18.255	0.000	0.000	0.000	9.918	0.000	9.918	0.000	0.000

Proposed Mankin's Crossing Facility With 15% Water Conservation:

Function	Total Cost (\$ Million)								
	1990	1995	2000	2005	2010	2015	2020	2025	2030
1. Construction Cost b/	11.384			7.966			7.966		
2. Engineering c/	0.797			0.558			0.558		
3. Land d/	0.001			0.000			0.000		
4. Surveying and Staking e/	0.342			0.239			0.239		
5. Legal and Administration f/	0.285			0.199			0.199		
6. Permitting and Fees g/	0.228			0.159			0.159		
7. Contingencies h/	1.138			0.797			0.797		
Total	14.174	0.000	0.000	9.918	0.000	0.000	9.918	0.000	0.000

a/ All costs assume 1990 dollars (0% annual inflation).

b/ Computed from Capital Cost Curves (Figure VII.7).

c/ Based on ASCE General Engineering Service Fee Curves.

d/ Based on current estimated cost of \$5,000/acre.

e/ Based on 3% of construction cost.

f/ Based on 2.5% of construction cost.

g/ Based on 2% of construction cost.

h/ Based on 10% of construction cost.

Figure VII.11
 Georgetown Regional Wastewater Planning Study
 Cumulative Treatment Cost for Single Regional Facility at Mankin's
 Crossing With and Without 15% Water Conservation

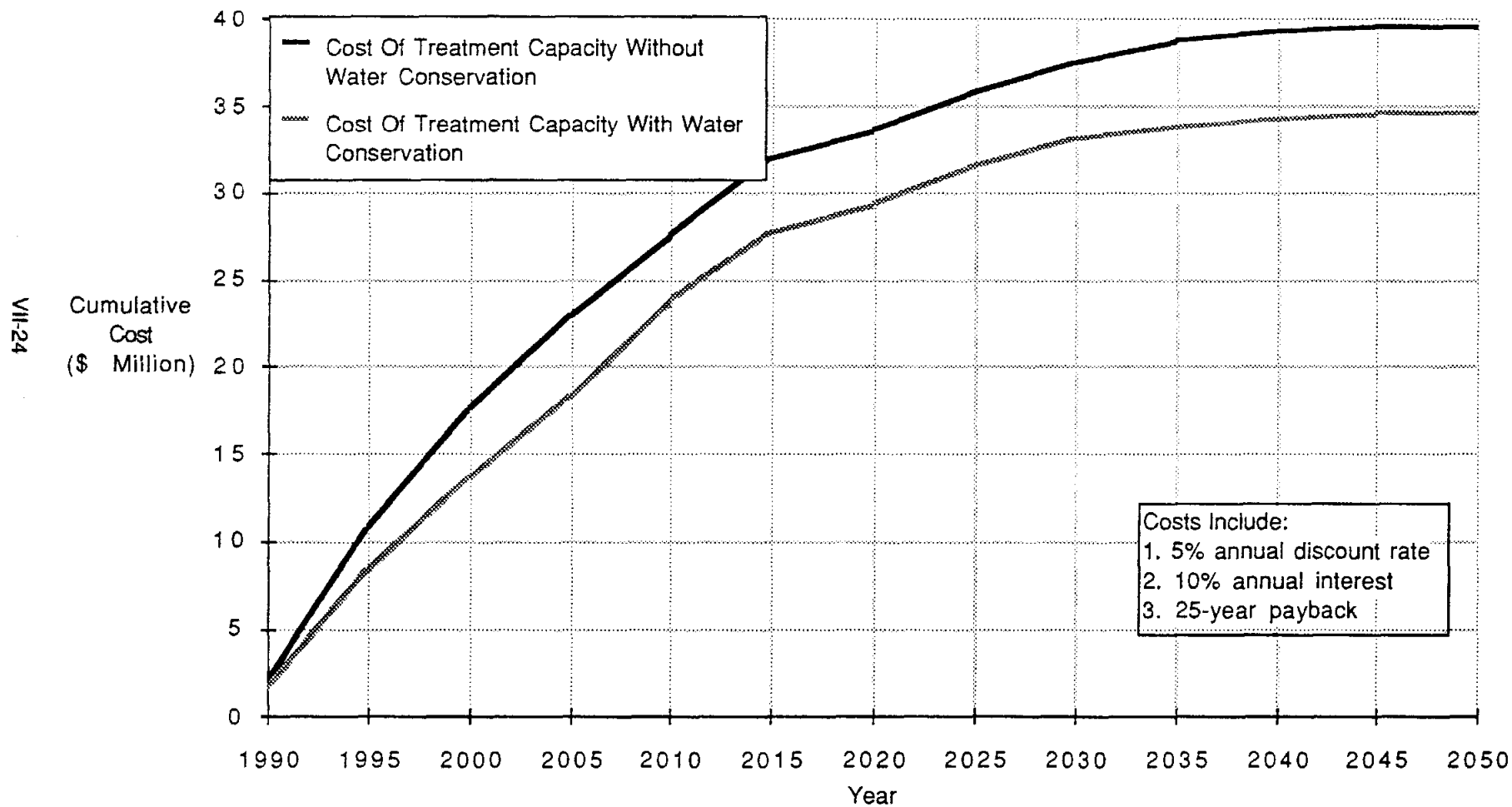

GEORGETOWN REGIONAL WASTEWATER PLANNING STUDY

BASIN	DESCRIPTION
0	Downtown (south)
1	North Fork San Gabriel
2	Downtown (north)
3a	South Fork San Gabriel
3b	South Fork San Gabriel
5a	Booty's Crossing
5b	Middle Fork San Gabriel
A	San Gabriel
B	Pecan Branch
B1	Berry Creek
D	Mankin's Branch
D1	North Mankin's Branch
E	Smith's Branch
F	1 - 35 (south)
U.R.	Middle Fork San Gabriel
C	Dry Berry Creek
SWID	Industrial District
(A3)	East Fork San Gabriel
F.S.	Westinghouse Road
A1	East Weir
A2	Middle Weir
A2a	West Weir

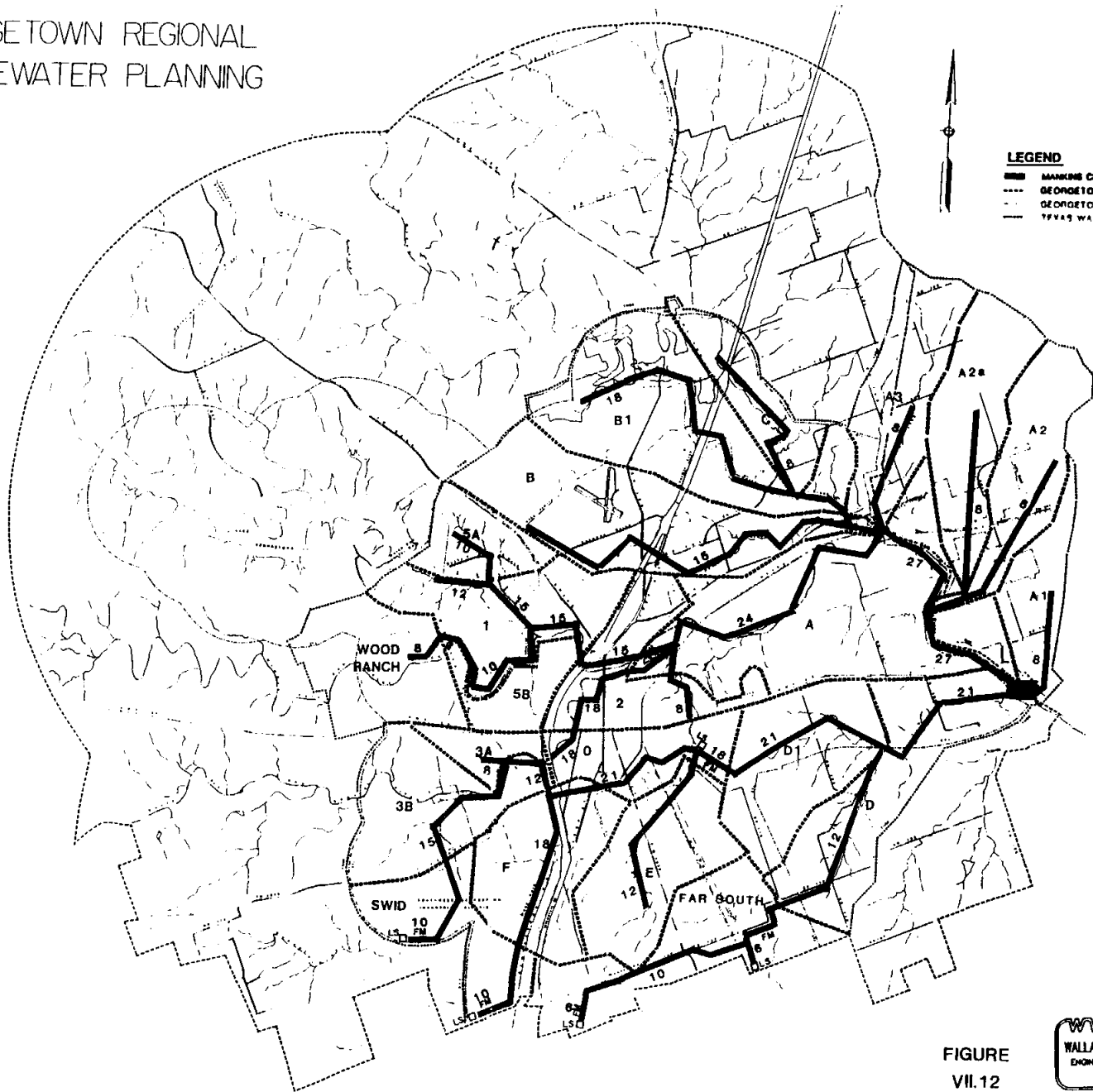

ALTERNATIVE A

FIGURE
VII.12



Table VII.5
Flows Used to Determine Pipe Sizing in Collection Systems
Single Plant Development Scenario

Interceptor	2030 Pop. Served	Contributing Areas	Total Average Daily Flows (MGD)	Peak Flow (MGD)
Mankin's Crossing WWTP				
A1	151		16,610	66,440
A"		A' + A2 + A2a	5,575,585	13,938,963
A2'		A2 + A2a	68,310	273,240
A2	314		34,540	138,160
A2a	307		33,770	135,080
A'		A + A3 + C + B + B1	5,507,275	13,768,188
A		2N + 2W + 2E + 0 + 219780	3,941,741	9,854,353
A3	412		45,320	181,280
B'		B + B1 + C	1,520,214	4,560,642
B	5,446		626,290	2,505,160
B1'		p	893,924	3,575,696
B1	7,207		828,805	3,315,220
C			65,119	260,476
D'		D1 + D	2,771,321	6,928,303
D	541	D + FS	289,489	1,157,95
FS			229,979	919,916
D1	682	D1' + D1	2,481,832	6,204,580
D1'		E + F + SWID + 3a + 3b	2,406,812	6,017,030
E	3,831		459,720	1,838,880
F	4,387	F + SWID(East)	924,431	3,697,724
F'		3b' + F	1,947,092	5,841,276
(.5)SWID(East)			441,861	1,767,444
0'	10,290		1,131,900	3,395,700
3a	748		82,280	329,120
3b	4,532		498,520	1,994,080
3b'		3a + 3b + (.5)SWID(East)	1,022,661	3,067,983
(.5)SWID(West)			441,861	1,767,444
2W		(.33)2 + 0	1,514,737	4,544,211
2E		(.33)2	382,837	1,531,348
2N		(.33)2 + 1"	1,824,387	5,473
1"		1 + 5a + 5b + WR	1,441,550	4,324,650
1'		(.66)1 + 5a	922,147	3,688,586
5a	2,524		277,640	1,110,560
5b	1,463	5b + WR	201,960	807,840
W.R.	373		41,030	164,120

divert these flows into the Smith Branch interceptor as well. Basin E gravity flows into the eastern end of the Smith Branch interceptor, and here, a lift station and force main will pump the cumulative flows into basin D1, where gravity flow is achieved past the western ridge line. The Far South basin, which is a combination of force mains and gravity lines, will be pumped into the southwest end of basin D which gravity flows and converges with basin D1. The cumulative flows from basins D and D1 gravity flow into the Mankin's Crossing wastewater treatment plant through the line called D'.

Contributing Flows North of Highway 29

To the west, flows contributing to line A east of the existing treatment plant include Wood Ranch into 5b, 5a and 1 into 1' (which parallels an existing 10" interceptor) and 1' and 5b into 1" (which parallels an existing 12" interceptor). Line 1" contributes to 2N (2 North), which parallels the same 12" interceptor as 1", and line 0 contributes to 2W (2 West). Lines 0 and 2W parallel an existing 10" interceptor, which leads to the existing treatment plant. Lines 2N and 2E (2 East) lead to the existing treatment plant as well. Line A is the main interceptor leading to the Mankin's Crossing wastewater treatment plant.

Lines B1 and C converge to form line B1'. Lines B1' and B converge to form line B'. Lines B' and A3 converge with line A to form line A'. Lines A2a and A2 converge to form line A2', which combines with line A' to form line A". Lines A1 and A" gravity flow into the Mankin's Crossing wastewater treatment plant.

VII.C.2 Two Plant Scenario

VII.C.2.a Wastewater Treatment Plants

Phasing of Facilities

In the two plant scenario the existing Georgetown plant is retained at its present capacity. However, its service area is reduced such that it will meet the demands of this area predicted for 2030. This has the effect of saving costs in two ways. First, the collection systems do not have to be modified once a decision is made as to which drainage areas are to be served by each plant. Second, the plant is currently under TWC mandate to upgrade treatment levels for all flows greater than 1.8 MGD. In order to retain its current level of operation, a higher level of treatment is required. Under this, and subsequent scenarios, the treatment capacity would be reduced to 1.7 MGD until 2015, and major improvements to the plant could be delayed, as described in Section VII.A.2.

A second, larger plant would be built at Mankin's Crossing. A 2 MGD plant built in 1990 would provide enough capacity until 2005. The addition of another 2 MGD of capacity at this time (plus an upgrade at the Georgetown plant in 2015) would extend the life of the plant until 2020. At this time an additional 1.5 MGD

would be needed to extend the life of the plant until 2030. In Figure VII.13 the flow capacities of each plant are superimposed on flow projections, demonstrating how the demand at each site would be met.

In Table VII.6 the drainage areas served by each plant are shown. In order to reduce the service area of the existing plant so that its capacity is adequate until the year 2030, some of its current drainage areas are diverted to Mankin's Crossing. Because State Highway 29 lies along a major ridge, the best way to achieve this is to divert all flows south of the highway to Mankin's Crossing. This leaves drainage areas 1, 2, 5a, 5b and the Woods Ranch in the Georgetown service area. In addition to serving all areas south of State Highway 29 (areas 0, 3a, 3b, SWID, E, F, F.S., D, and D1), the Mankin's Crossing plant would serve the Berry Creek watershed (areas B, B1 and C), Weir (A1, A2, A2a and A3) and drainage area A.

The same calculations were performed under conditions of 15 percent water conservation. Table VII.7 shows how wastewater generation would be reduced under this scenario. By 2030 total flows to the Georgetown plant would be reduced to 2.2 MGD, and to the Mankin's Crossing plant to 4.5 MGD. As a result, upgrading the Georgetown plant could be delayed further, to 2020, and the Mankin's Crossing plant could be built in three, smaller increments. Starting with a 1.5 MGD plant in 1990, Mankin's Crossing would not have to be increased to 3 MGD until the year 2000. The addition of another 1.5 MGD of capacity in the year 2015 would provide enough capacity until 2030 (Figure VII.14).

Cost Estimates

The two plant scenario assumes that the existing Georgetown treatment plant will be upgraded in 2015 without water conservation and in 2020 with conservation. This is estimated to cost a total of \$1.26 million. A second facility is built at Mankin's Crossing at a treatment level of 10/2/6. A 2 MGD plant would cost a total of \$6.08 million (approximately the same as a 10/3/4 plant) and a 1.5 MGD plant (under conditions of 15 percent water conservation) would cost a total of \$4.75 million, the initial phases proposed in 1990 under the two plant scenarios. Each additional 1.5 MGD increase in capacity is also estimated at \$4.75 million (Tables VII.8 and VII.9).

Each set of figures for capital outlay was amortized over 25 years at 10 percent interest, and the total expense for each year was then converted to present value using a 5 percent discount rate. The cumulative cost for each scenario is shown in Figure VII.15. Without water conservation this amounts to a total of \$17.06 million and with conservation to \$15.24 million.

Figure VII.13
 Georgetown Regional Wastewater Planning Study
 Possible Capacity Build-out for City of Georgetown
 and Mankin's Crossing Plants

VII-29

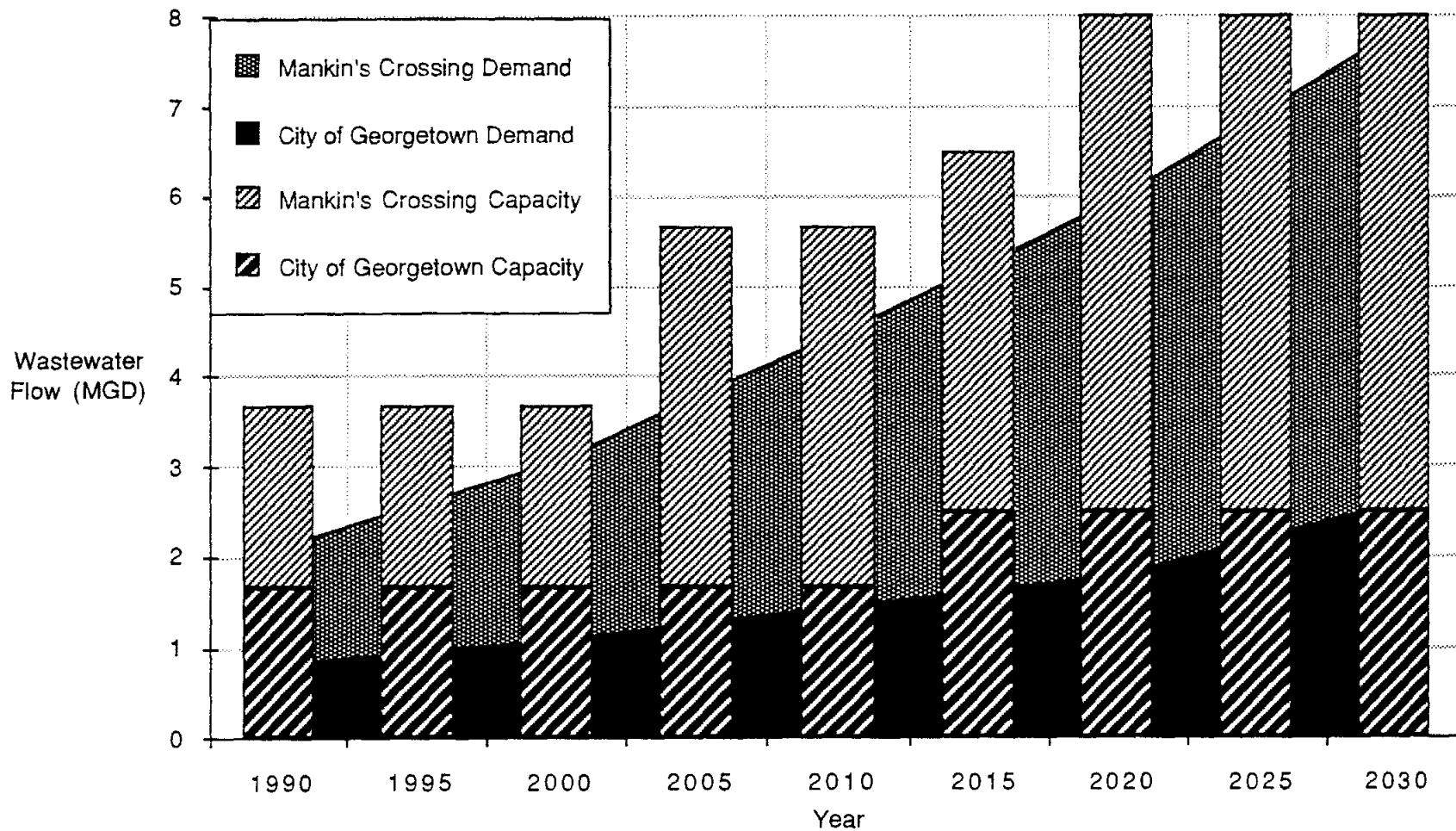

Table VII.6
Georgetown Regional Wastewater Planning Study
Wastewater Flow Projections for a City of Georgetown
and Mankin's Crossing Plants

Basins Contributing to Existing City of Georgetown Facility:

Basin	Description	Projected Wastewater Flow (MGD)				
		1990	2000	2010	2020	2030
1	North Fork San Gabriel	0.339	0.456	0.666	0.794	0.962
2	Downtown (north)	0.334	0.410	0.610	0.743	1.149
5a	Booty's Crossing	0.033	0.076	0.120	0.210	0.278
5b	Middle Fork San Gabriel	0.032	0.046	0.082	0.102	0.161
W.R.	Wood Ranch	0.015	0.020	0.025	0.035	0.041
		0.753	1.008	1.503	1.884	2.591

Basins Contributing to a Mankin's Crossing Facility:

Basin	Description	Projected Wastewater Flow (MGD)				
		1990	2000	2010	2020	2030
0	Downtown (south)	0.378	0.568	0.825	0.916	1.132
3a	South Fork San Gabriel	0.000	0.031	0.050	0.063	0.082
3b	South Fork San Gabriel	0.138	0.203	0.289	0.394	0.499
A	San Gabriel	0.039	0.070	0.126	0.162	0.220
B	Pecan Branch	0.178	0.266	0.362	0.471	0.626
B1	Berry Creek	0.219	0.326	0.514	0.623	0.828
C	Dry Berry Creek	0.010	0.025	0.038	0.050	0.065
D	Mankin's Branch	0.000	0.017	0.030	0.045	0.060
D1	North Mankin's Branch	0.014	0.021	0.036	0.049	0.075
E	Smith's Branch	0.033	0.069	0.145	0.304	0.460
F	I - 35 South	0.076	0.148	0.284	0.373	0.483
SWID	Industrial District	0.100	0.175	0.230	0.300	0.353
F.S.	Westinghouse Road	0.075	0.100	0.150	0.195	0.230
A1	East Weir	0.004	0.007	0.010	0.013	0.017
A2	Middle Weir	0.010	0.015	0.020	0.025	0.035
A2a	West Weir	0.009	0.015	0.020	0.026	0.034
A3	East Fork San Gabriel	0.012	0.020	0.025	0.035	0.045
		1.295	2.076	3.154	4.044	5.244

Total Required Treatment Capacity:

Basin	Description	Projected Wastewater Flow (MGD)				
		1990	2000	2010	2020	2030
All	Total Wastewater Flow	2.048	3.084	4.657	5.928	7.835

Table VII.7
 Georgetown Regional Wastewater Planning Study
 Wastewater Flow Projections for a City of Georgetown
 and Mankin's Crossing Plants With 15% Water Conservation

Basins Contributing to Existing City of Georgetown Facility:

Basin	Description	Projected Wastewater Flow (MGD)				
		1990	2000	2010	2020	2030
1	North Fork San Gabriel	0.288	0.388	0.566	0.675	0.818
2	Downtown (north)	0.284	0.349	0.519	0.632	0.977
5a	Booty's Crossing	0.028	0.065	0.102	0.179	0.236
5b	Middle Fork San Gabriel	0.027	0.039	0.070	0.087	0.137
W.R.	Wood Ranch	0.013	0.017	0.021	0.030	0.035
		0.640	0.858	1.278	1.603	2.202

Basins Contributing to a Mankin's Crossing Facility:

Basin	Description	Projected Wastewater Flow (MGD)				
		1990	2000	2010	2020	2030
0	Downtown (south)	0.321	0.483	0.701	0.779	0.962
3a	South Fork San Gabriel	0.000	0.026	0.043	0.054	0.070
3b	South Fork San Gabriel	0.117	0.173	0.246	0.335	0.424
A	San Gabriel	0.033	0.060	0.107	0.138	0.187
B	Pecan Branch	0.151	0.226	0.308	0.400	0.532
B1	Berry Creek	0.186	0.277	0.437	0.530	0.704
C	Dry Berry Creek	0.009	0.021	0.032	0.043	0.055
D	Mankin's Branch	0.000	0.014	0.026	0.038	0.051
D1	North Mankin's Branch	0.012	0.018	0.031	0.042	0.064
E	Smith's Branch	0.028	0.059	0.123	0.258	0.391
F	I - 35 South	0.065	0.126	0.241	0.317	0.411
SWID	Industrial District	0.085	0.149	0.196	0.255	0.300
F.S.	Westinghouse Road	0.064	0.085	0.128	0.166	0.196
A1	East Weir	0.003	0.006	0.009	0.011	0.014
A2	Middle Weir	0.009	0.013	0.017	0.021	0.030
A2a	West Weir	0.008	0.013	0.017	0.022	0.029
A3	East Fork San Gabriel	0.010	0.017	0.021	0.030	0.038
		1.101	1.766	2.683	3.439	4.457

Total Required Treatment Capacity:

Basin	Description	Projected Wastewater Flow (MGD)				
		1990	2000	2010	2020	2030
All	Total Wastewater Flow	1.741	2.624	3.961	5.042	6.660

Figure VII.14
 Georgetown Regional Wastewater Planning Study
 Possible Capacity Build-out for City of Georgetown
 and Mankin's Crossing Plants With 15% Water Conservation

VII-32

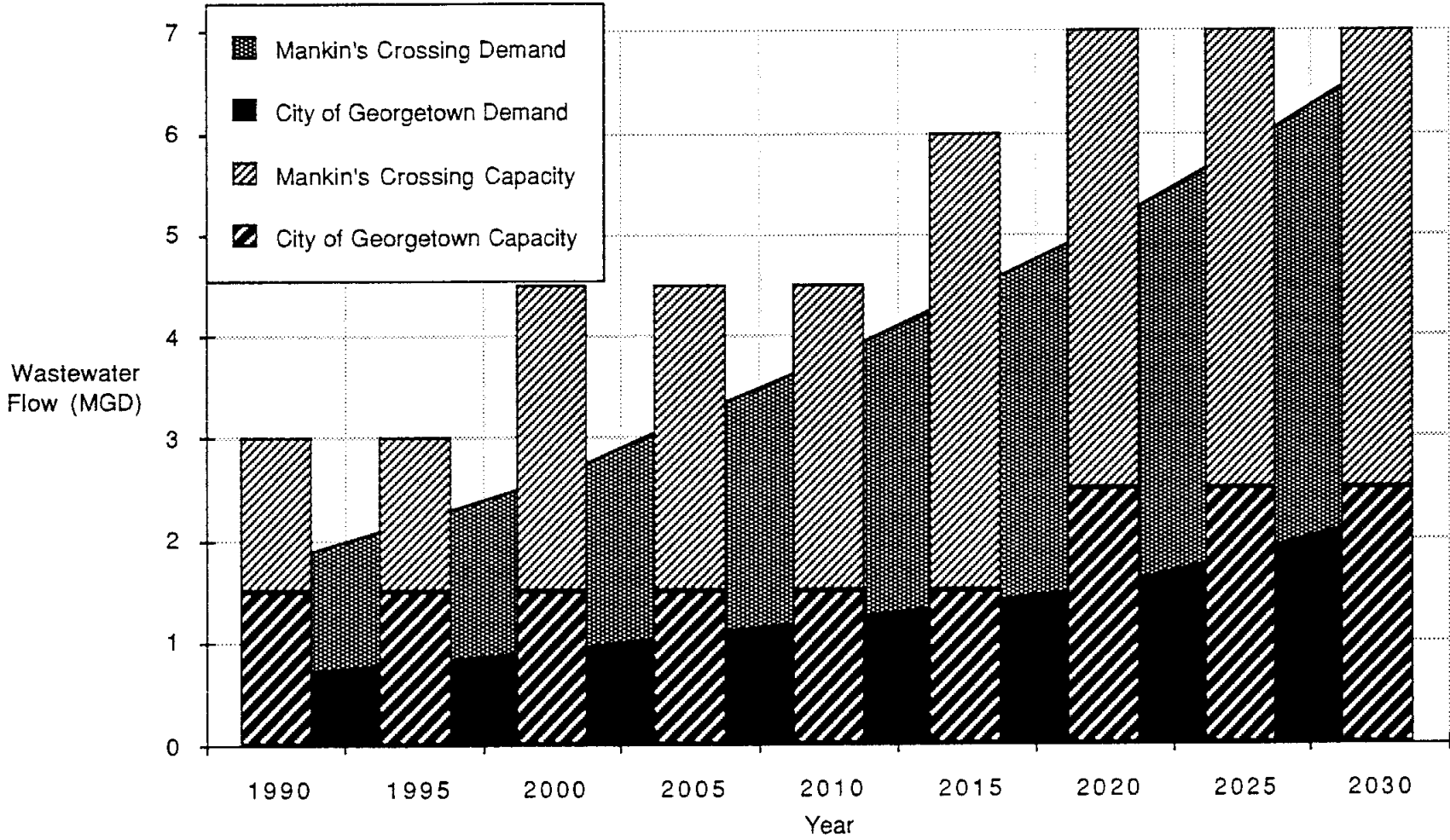

Table VII.8
 Estimated Cost of City of Georgetown and Mankin's Crossing
 Wastewater Treatment Plants Without Water Conservation (1990 Through 2030) a/

Existing Georgetown Facility:

Function	Total Cost (\$ Million)									
	1990	1995	2000	2005	2010	2015	2020	2025	2030	
1. Construction Cost b/						1.000				
2. Engineering c/						0.081				
3. Land d/						0.000				
4. Surveying and Staking e/						0.030				
5. Legal and Administration f/						0.025				
6. Permitting and Fees g/						0.020				
7. Contingencies h/						0.100				
Total	0.000	0.000	0.000	0.000	0.000	1.256	0.000	0.000	0.000	

Proposed Mankin's Crossing Facility:

Function	Total Cost (\$ Million)									
	1990	1995	2000	2005	2010	2015	2020	2025	2030	
1. Construction Cost b/	4.880			4.880			3.786			
2. Engineering c/	0.344			0.344			0.267			
3. Land d/	0.001			0.001			0.001			
4. Surveying and Staking e/	0.146			0.146			0.114			
5. Legal and Administration f/	0.122			0.122			0.095			
6. Permitting and Fees g/	0.098			0.098			0.076			
7. Contingencies h/	0.488			0.488			0.379			
Total	6.079	0.000	0.000	6.079	0.000	0.000	4.716	0.000	0.000	

Total Projected Expenditures Without Water Conservation:

	Total Cost (\$ Million)									
	1990	1995	2000	2005	2010	2015	2020	2025	2030	
Total Cost	6.079	0.000	0.000	6.079	0.000	1.256	4.716	0.000	0.000	

- a/ All costs assume 1990 dollars (0% annual inflation).
- b/ Computed from Capital Cost Curves (Figure VII.7).
- c/ Based on ASCE General Engineering Service Fee Curves.
- d/ Based on current estimated cost of \$5,000/acre.
- e/ Based on 3% of construction cost.
- f/ Based on 2.5% of construction cost.
- g/ Based on 2% of construction cost.
- h/ Based on 10% of construction cost.

Table VII.9
 Estimated Cost of City of Georgetown and Mankin's Crossing
 Wastewater Treatment Plants With 15% Water Conservation (1990 Through 2030)

Existing Georgetown Facility:

Function	Total Cost (\$ Million)								
	1990	1995	2000	2005	2010	2015	2020	2025	2030
1. Construction Cost b/							1.000		
2. Engineering c/							0.081		
3. Land d/							0.000		
4. Surveying and Staking e/							0.030		
5. Legal and Administration f/							0.025		
6. Permitting and Fees g/							0.020		
7. Contingencies h/							0.100		
Total	0.000	0.000	0.000	0.000	0.000	0.000	1.256	0.000	0.000

Proposed Mankin's Crossing Facility:

Function	Total Cost (\$ Million)								
	1990	1995	2000	2005	2010	2015	2020	2025	2030
1. Construction Cost b/	3.786		3.786			3.786			
2. Engineering c/	0.295		0.273			0.273			
3. Land d/	0.001		0.000			0.000			
4. Surveying and Staking e/	0.114		0.114			0.114			
5. Legal and Administration f/	0.095		0.095			0.095			
6. Permitting and Fees g/	0.076		0.076			0.076			
7. Contingencies h/	0.379		0.379			0.379			
Total	4.745	0.000	4.721	0.000	0.000	4.721	0.000	0.000	0.000

Total Projected Expenditures With 15% Water Conservation:

Total Cost	Total Cost (\$ Million)								
	1990	1995	2000	2005	2010	2015	2020	2025	2030
Total Cost	4.745	0.000	4.721	0.000	0.000	4.721	1.256	0.000	0.000

- a/ All costs assume 1990 dollars (0% annual inflation).
- b/ Computed from Capital Cost Curves (Figure VII.7).
- c/ Based on ASCE General Engineering Service Fee Curves.
- d/ Based on current estimated cost of \$5,000/acre.
- e/ Based on 3% of construction cost.
- f/ Based on 2.5% of construction cost.
- g/ Based on 2% of construction cost.
- h/ Based on 10% of construction cost.

Figure VII.15
 Georgetown Regional Wastewater Planning Study
 Cumulative Treatment Cost for City of Georgetown and Mankin's
 Crossing Plants With and Without 15% Water Conservation

VII-35

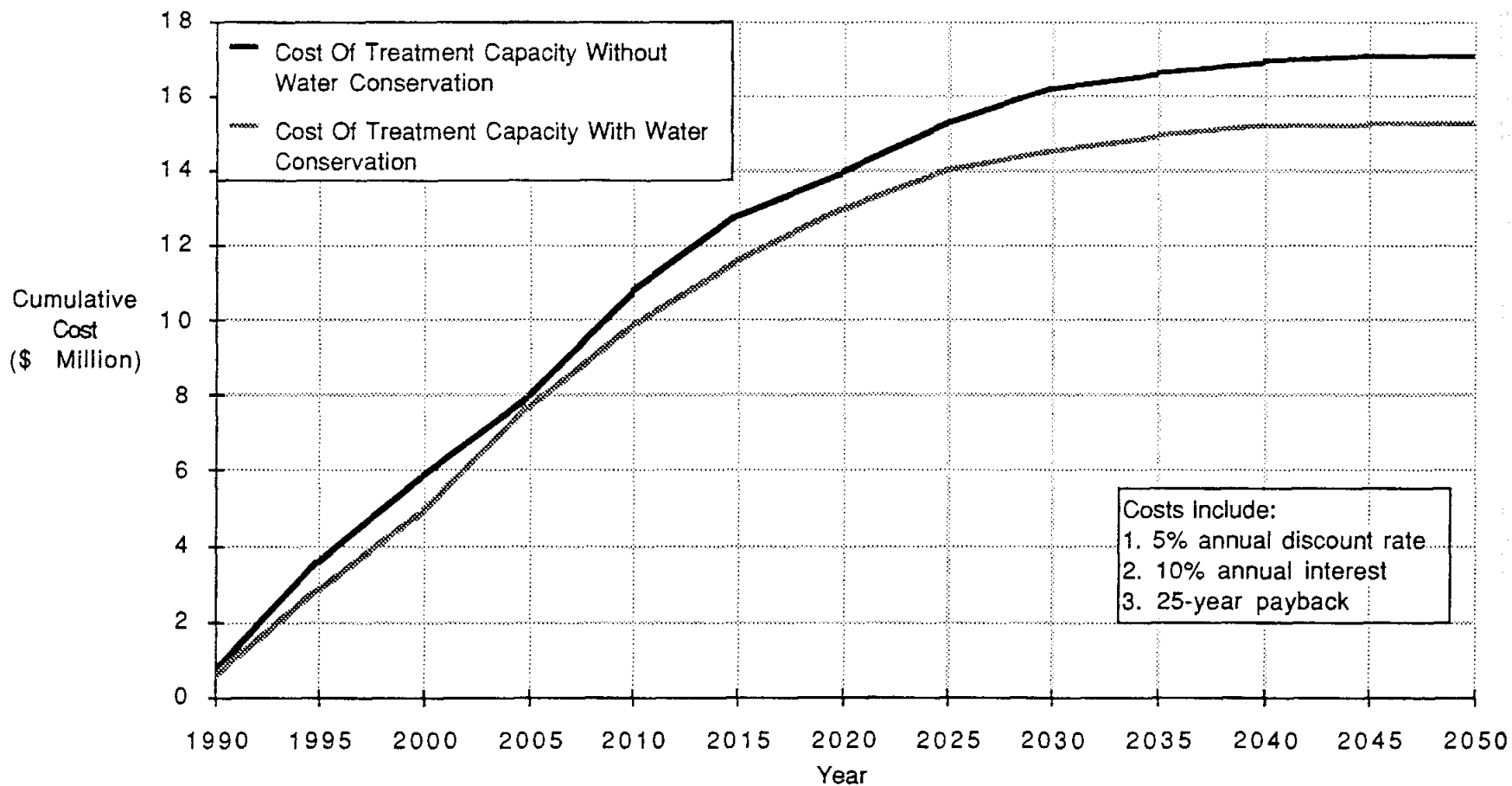

VII.C.2.b Wastewater Collection Systems

As with the one plant scenario, the two plant collection system will rely heavily on gravity flow. Highway 29 represents the division of flows coming in from the north and south. The existing plant is kept at 2.5 MGD by diverting basin 0 to the Mankin's Crossing plant (see Figure VII.16 and Table VII.10).

Contributing Flows South of Highway 29

Flows from basins 3a and 3b are diverted to the existing 12" Smith Branch interceptor, F', through the force main 3b'. As the Southwestern Industrial District develops, force mains leading to basins 3b and F will divert SWID flows into the Smith Branch interceptor as well.

Basin E gravity flows into the eastern end of the Smith Branch interceptor, and here, a lift station and force main will pump the cumulative flows into basin D1, where gravity flow is achieved past the western ridge line. Flows from basin 0, through a series of gravity sewers and force mains, will also be diverted to basin D1 through the force main 0'.

A combination of force mains and gravity lines will pump sewage from the Far South basin into the southwest end of basin D, which gravity flows and converges with basin D1. The cumulative flows from basins D and D1 gravity flow into the Mankin's Crossing wastewater treatment plant through the line called D'.

Contributing Flows North of Highway 29

To the west, flows contributing to the existing treatment plant include Wood Ranch into 5b, 5a and 1 into 1' (which parallels an existing 10" interceptor) and 1' and 5b into 1" (which parallels an existing 12" interceptor). Line 1" contributes to 2N (2 North), which parallels the same 12" interceptor as 1" and leads to the existing treatment plant. Lines 2E (2 East) and 2W (2 West) lead to the existing treatment plant as well.

Lines B1 and C converge to form line B1'. Lines B1' and B converge to form line B'. Lines A and A3 converge with line B' to form line A'. Lines A1 and A" gravity flow into the Mankin's Crossing wastewater treatment plant.

GEORGETOWN REGIONAL WASTEWATER PLANNING STUDY

BASIN	DESCRIPTION
0	Downtown (south)
1	North Fork San Gabriel
2	Downtown (north)
3a	South Fork San Gabriel
3b	South Fork San Gabriel
5a	Booty's Crossing
5b	Middle Fork San Gabriel
A	San Gabriel
B	Pecan Branch
B1	Berry Creek
D	Mankin's Branch
D1	North Mankin's Branch
E	Salth's Branch
F	I - 35 (south)
M.R.	Middle Fork San Gabriel
C	Dry Berry Creek
SWID	Industrial District
(A3)	East fork San Gabriel
F.S.	Westinghouse Road
A1	East Weir
A2	Middle Weir
A2a	West Weir

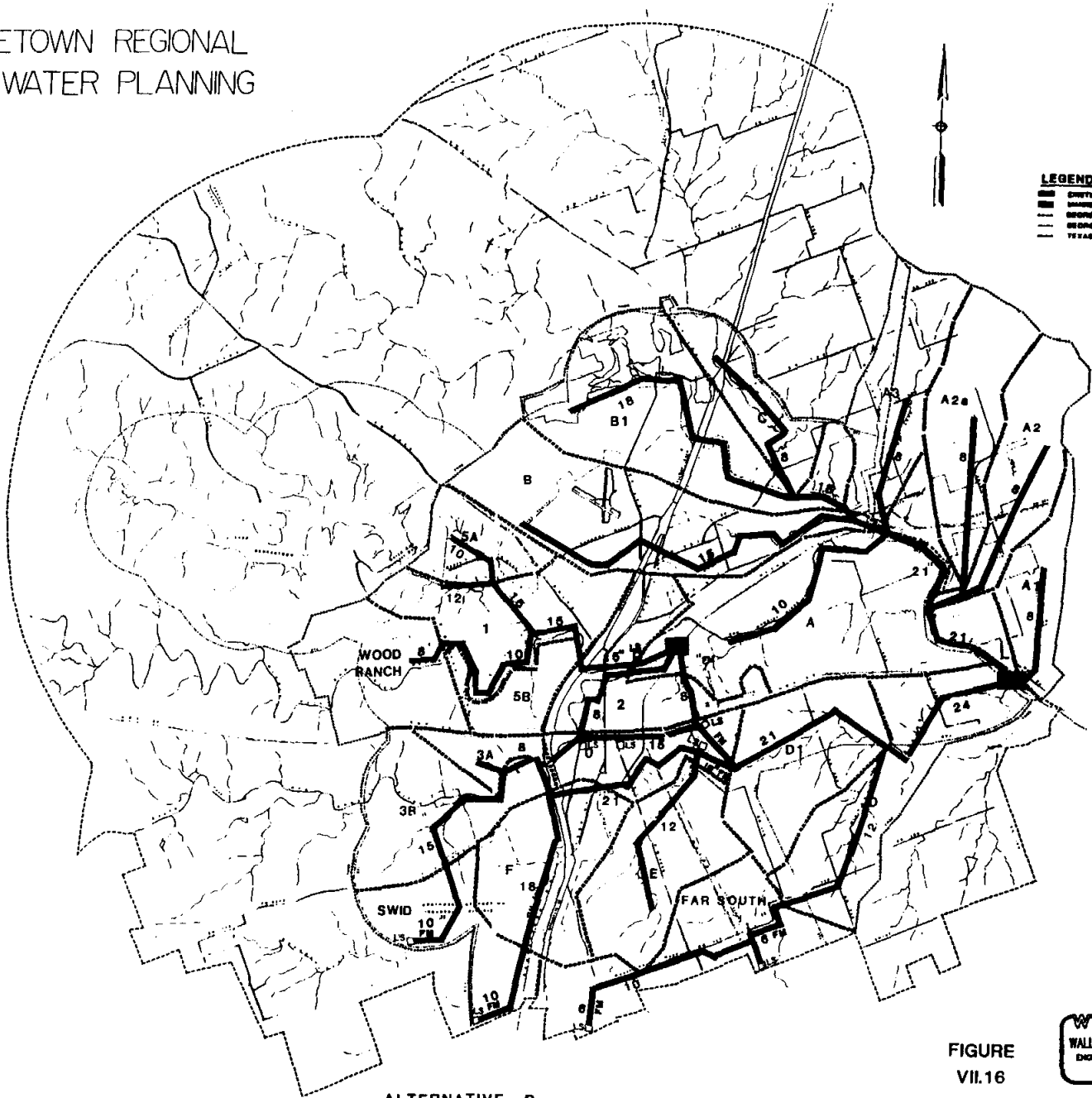

ALTERNATIVE B

FIGURE VII.16

WWR
WALLACE, WINKLER & RICE, INC.
 ENGINEERS • PLANNERS • SURVEYORS
 VACS • TRIPLE

Table VII.10
Flows Used to Determine Pipe Sizing In Collection Systems
2 Plant Development Scenario

Interceptor	2030 Pop. Served	Contributing Areas	Total Average Daily Flows (MGD)	Peak Flow (MGD)
Mankin's Crossing WWTP				
A1	151		16,610	66,440
A"		A' + A2 + A2a	1,853,624	5,560,872
A2'		A2 + A2a	68,310	273,240
A2	314		34,540	138,160
A2a	307		33,770	135,080
A'		A + A3 + C + B + B1	1,785,314	5,355,942
A	1,998		219,780	879,120
A3	412		45,320	181,280
B'		B + B1 + C	1,520,214	4,560,642
B	5,446		626,290	2,505,160
B1'		B1 + C	893,924	3,575,696
B1	7,207		828,805	3,315,220
C			65,119	260,476
D'		D1 + D	3,903,221	9,758,053
D	541	D + FS	289,489	1,157,95
FS			229,979	919,916
D1	682	D1' + 0' + D1	3,613,732	9,034,330
D1'		3b + E + F + SWID(East)	2,406,812	7,220,436
E	3,831		459,720	1,838,880
F	4,387	F + SWID(East)	924,431	3,697,724
F'		3b' + F	1,947,092	5,841,276
(.5)SWID(East)			441,861	1,767,444
0'	10,290		1,131,900	3,395,700
0 West			565,950	2,263,800
0 East			565,950	2,263,800
3a	748		82,280	329,120
3b	4,532		498,520	1,994,080
3b'		3a + 3b + (.5)SWID(East)	1,022,661	3,067,983
(.5)SWID(West)			441,861	1,767,444
Georgetown WWTP				
2W		(.33)2	382,837	1,531,348
2E		(.33)2	382,837	1,531,348
2N		(.33)2 + 1"	1,824,387	5,473
1"		1 + 5a + 5b + WR	1,441,550	4,324,650
1'		(.66)1 + 5a	922,147	3,688,586
5a	2,524		277,640	1,110,560
5b	1,463	5b + WR	201,960	807,840
W.R.	373		41,030	164,120
1	8,745		317,444	1,269,776

VII.C.3 Three Plant Scenario

VII.C.3.a Wastewater Treatment Plants

Phasing of Facilities

The three plant scenario assumes that an additional plant would be built at Berry Creek. The existing Georgetown plant would serve the same areas as those described in the previous scenario, with an upgrade in 2015 without water conservation measures, and in 2020 with water conservation.

A plant at Berry Creek would serve the Berry Creek watershed (drainage areas B, B1 and C) plus drainage area A. This results in total wastewater flows to this plant of 1.7 MGD by 2030 without water conservation and 1.5 MGD with conservation (Tables VII.11 and VII.12). The remaining basins would be served by Mankin's Crossing. Figure VII.17 shows the total capacity served by each plant under a no conservation scenario. In Figure VII.18 the overall reduction in flows as a result of conservation is shown. These figures also show the requisite plant capacities for each scenario.

Without water conservation a 1 MGD plant at Berry Creek built in 1990 would have to be increased to 2 MGD in 2015. At Mankin's Crossing a 1.5 MGD plant could be built in 1990 and increased to 3.5 MGD in 2005. With water conservation, the Berry Creek plant could be built in two 0.75 MGD increments, in 1990 and 2010. This would provide adequate capacity for the whole of the planning period. At Mankin's Crossing only two 1.5 MGD components would be required, one in 1990 and the other in 2010.

Cost Estimates

In the three plant scenario the capital costs in 1990 are the first phases of an additional plant at both Mankin's Crossing and Berry Creek, both at a treatment level of 10/3/4. A 1 MGD plant at Berry Creek is estimated to cost a total of \$3.32 million and a 1.5 MGD plant at Mankin's Crossing would cost \$4.75 million. By 2005 additional capacity would be required at Mankin's Crossing at a cost of \$6.11 million. In 2015 the existing Georgetown plant would be upgraded at a cost of 1.26 million and an additional 1 MGD of capacity would be added at Berry Creek at a cost of \$3.32 million (Table VII.13).

Using a scenario in which water conservation results in a 15 percent reduction in wastewater flows, the initial phase would be reduced to a cost of \$2.57 million at Berry Creek with a similar expenditure in 2010. Additional capacity would also be required at Mankin's Crossing in 2010 at a cost of \$4.74 million. Improvements to the Georgetown plant would cost \$1.26 million in 2020 (Table VII.14).

The capital costs amortized over 25 years at 10 percent interest were summed for each year. Using a 5 percent discount rate, annual expenditures were converted to present value. The cumulative costs are

Table VII.11
Georgetown Regional Wastewater Planning Study
Wastewater Flow Projections for a City of Georgetown,
Berry Creek, and Mankin's Crossing Plants

Basins Contributing to Existing City of Georgetown Facility:

Basin	Description	Projected Wastewater Flow (MGD)				
		1990	2000	2010	2020	2030
1	North Fork San Gabriel	0.339	0.456	0.666	0.794	0.962
2	Downtown (north)	0.334	0.410	0.610	0.743	1.149
5a	Booty's Crossing	0.033	0.076	0.120	0.210	0.278
5b	Middle Fork San Gabriel	0.032	0.046	0.082	0.102	0.161
W.R.	Wood Ranch	0.015	0.020	0.025	0.035	0.041
		0.753	1.008	1.503	1.884	2.591

Basins Contributing to a Berry Creek Facility:

Basin	Description	Projected Wastewater Flow (MGD)				
		1990	2000	2010	2020	2030
A	San Gabriel	0.039	0.070	0.126	0.162	0.220
B	Pecan Branch	0.178	0.266	0.362	0.471	0.626
B1	Berry Creek	0.219	0.326	0.514	0.623	0.828
C	Dry Berry Creek	0.010	0.025	0.038	0.050	0.065
		0.446	0.687	1.040	1.306	1.739

Basins Contributing to a Mankin's Crossing Facility:

Basin	Description	Projected Wastewater Flow (MGD)				
		1990	2000	2010	2020	2030
0	Downtown (south)	0.378	0.568	0.875	0.916	1.132
3a	South Fork San Gabriel	0.000	0.031	0.050	0.063	0.082
3b	South Fork San Gabriel	0.138	0.203	0.289	0.394	0.499
D	Mankin's Branch	0.000	0.017	0.030	0.045	0.060
D1	North Mankin's Branch	0.014	0.021	0.036	0.049	0.075
E	Smith's Branch	0.033	0.069	0.145	0.304	0.460
F	I- 35 South	0.076	0.148	0.284	0.373	0.483
SWID	Industrial District	0.100	0.175	0.230	0.300	0.353
F.S.	Westinghouse Road	0.075	0.100	0.150	0.195	0.230
A1	East Weir	0.004	0.007	0.010	0.013	0.017
A2	Middle Weir	0.010	0.015	0.020	0.025	0.035
A2a	West Weir	0.009	0.015	0.020	0.026	0.034
A3	East Fork San Gabriel	0.012	0.020	0.025	0.035	0.045
		0.849	1.389	2.114	2.738	3.505

Total Required Treatment Capacity:

Basin	Description	Projected Wastewater Flow (MGD)				
		1990	2000	2010	2020	2030
All	Total Wastewater Flow	2.048	3.084	4.657	5.928	7.835

Table VII.12
Georgetown Regional Wastewater Planning Study
Wastewater Flow Projections for a City of Georgetown, Berry Creek,
and Mankin's Crossing Plants With 15% Water Conservation

Basins Contributing to Existing City of Georgetown Facility:

Basin	Description	Projected Wastewater Flow (MGD)				
		1990	2000	2010	2020	2030
1	North Fork San Gabriel	0.288	0.388	0.566	0.675	0.818
2	Downtown (north)	0.284	0.349	0.519	0.632	0.977
5a	Booty's Crossing	0.028	0.065	0.102	0.179	0.236
5b	Middle Fork San Gabriel	0.027	0.039	0.070	0.087	0.137
W.R.	Wood Ranch	0.013	0.017	0.021	0.030	0.035
		0.640	0.858	1.278	1.603	2.202

Basins Contributing to a Berry Creek Facility:

Basin	Description	Projected Wastewater Flow (MGD)				
		1990	2000	2010	2020	2030
A	San Gabriel	0.033	0.060	0.107	0.138	0.187
B	Pecan Branch	0.151	0.226	0.308	0.400	0.532
B1	Berry Creek	0.186	0.277	0.437	0.530	0.704
C	Dry Berry Creek	0.009	0.021	0.032	0.043	0.055
		0.379	0.584	0.884	1.111	1.478

Basins Contributing to a Mankin's Crossing Facility:

Basin	Description	Projected Wastewater Flow (MGD)				
		1990	2000	2010	2020	2030
0	Downtown (south)	0.321	0.483	0.700	0.779	0.962
3a	South Fork San Gabriel	0.000	0.026	0.043	0.054	0.070
3b	South Fork San Gabriel	0.117	0.173	0.246	0.335	0.424
D	Mankin's Branch	0.000	0.014	0.026	0.038	0.051
D1	North Mankin's Branch	0.012	0.018	0.031	0.042	0.064
E	Smith's Branch	0.028	0.059	0.123	0.258	0.391
F	I - 35 South	0.065	0.126	0.241	0.317	0.411
SWID	Industrial District	0.085	0.149	0.196	0.255	0.300
F.S.	Westinghouse Road	0.064	0.085	0.128	0.166	0.196
A1	East Weir	0.003	0.006	0.009	0.011	0.014
A2	Middle Weir	0.009	0.013	0.017	0.021	0.030
A2a	West Weir	0.008	0.013	0.017	0.022	0.029
A3	East Fork San Gabriel	0.010	0.017	0.021	0.030	0.038
		0.722	1.182	1.799	2.328	2.979

Total Required Treatment Capacity:

Basin	Description	Projected Wastewater Flow (MGD)				
		1990	2000	2010	2020	2030
All	Total Wastewater Flow	1.741	2.624	3.961	5.042	6.660

Figure VII.17
 Georgetown Regional Wastewater Planning Study
 Possible Capacity Build-out for City of Georgetown,
 Berry Creek, and Mankin's Crossing Plants

VII-42

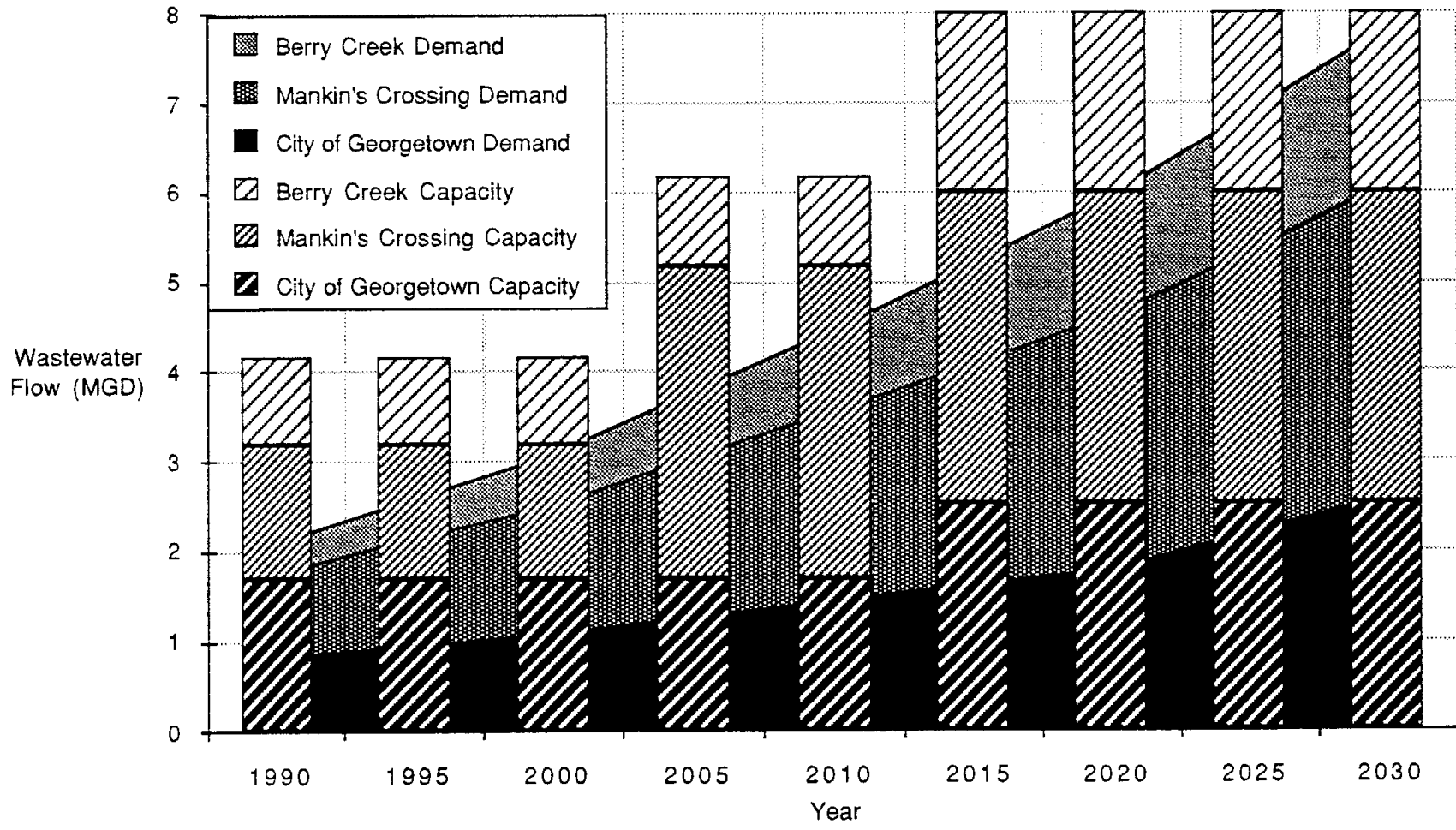

Figure VII.18
 Georgetown Regional Wastewater Planning Study
 Possible Capacity Build-out for City of Georgetown,
 Berry Creek, and Mankin's Crossing Plants With 15% Water Conservation

VII-43

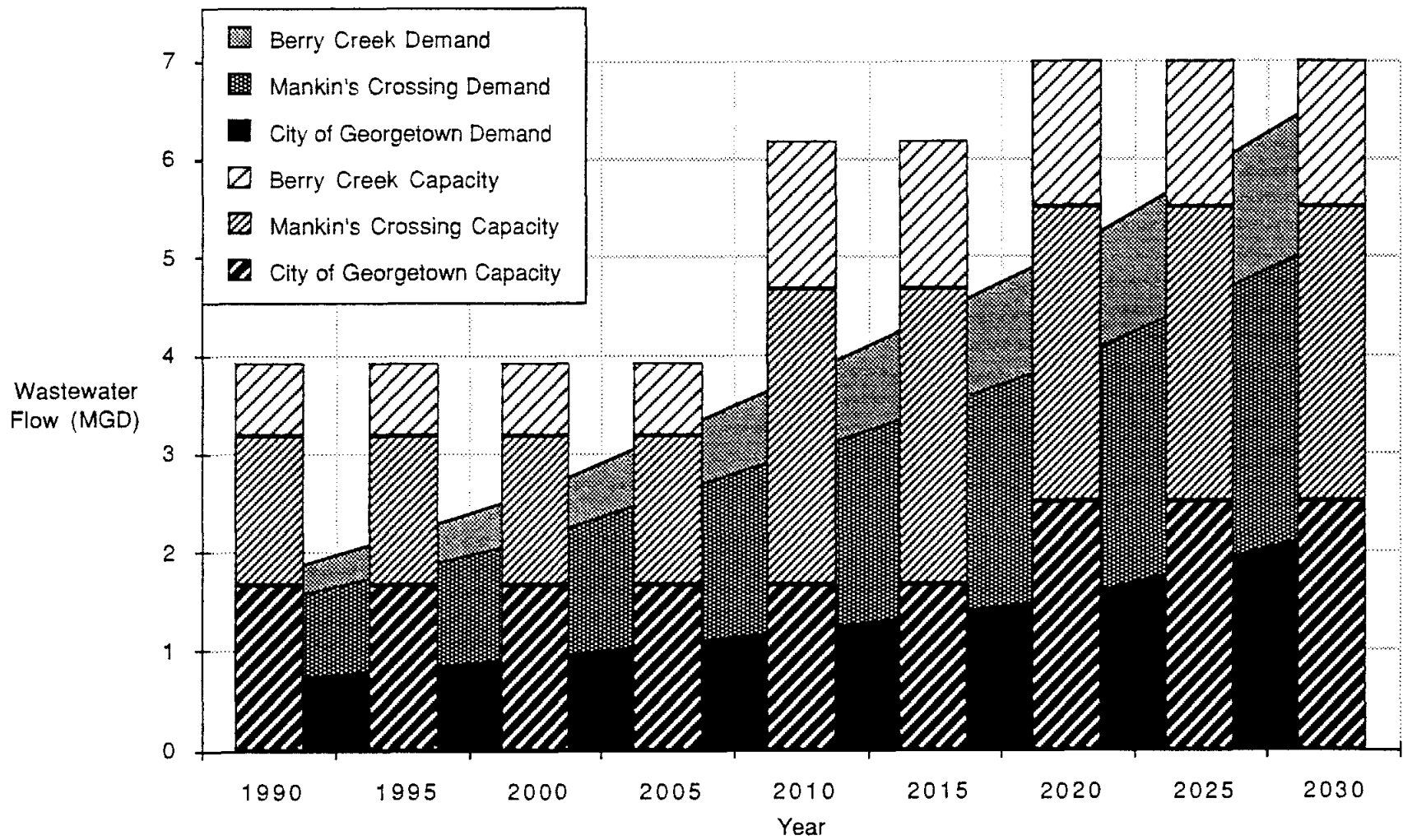

Table VII.13
 Estimated Cost of City of Georgetown, Berry Creek, and Mankin's Crossing
 Wastewater Treatment Plants Without Water Conservation (1990 Through 2030) a/

Existing Georgetown Facility:

Function	Total Cost (\$ Million)								
	1990	1995	2000	2005	2010	2015	2020	2025	2030
1. Construction Cost b/						1.000			
2. Engineering c/						0.081			
3. Land d/						0.000			
4. Surveying and Staking e/						0.030			
5. Legal and Administration f/						0.025			
6. Permitting and Fees g/						0.020			
7. Contingencies h/						0.100			
Total	0.000	0.000	0.000	0.000	0.000	1.256	0.000	0.000	0.000

Proposed Berry Creek Facility:

Function	Total Cost (\$ Million)								
	1990	1995	2000	2005	2010	2015	2020	2025	2030
1. Construction Cost b/	2.646					2.646			
2. Engineering c/	0.206					0.206			
3. Land d/	0.001					0.000			
4. Surveying and Staking e/	0.079					0.079			
5. Legal and Administration f/	0.066					0.066			
6. Permitting and Fees g/	0.053					0.053			
7. Contingencies h/	0.265					0.265			
Total	3.316	0.000	0.000	0.000	0.000	3.315	0.000	0.000	0.000

Proposed Mankin's Crossing Facility:

Function	Total Cost (\$ Million)								
	1990	1995	2000	2005	2010	2015	2020	2025	2030
1. Construction Cost b/	3.786			4.880					
2. Engineering c/	0.295			0.381					
3. Land d/	0.001			0.000					
4. Surveying and Staking e/	0.114			0.146					
5. Legal and Administration f/	0.095			0.122					
6. Permitting and Fees g/	0.076			0.098					
7. Contingencies h/	0.379			0.488					
Total	4.745	0.000	0.000	6.115	0.000	0.000	0.000	0.000	0.000

Total Projected Expenditures Without Water Conservation:

	Total Cost (\$ Million)								
	1990	1995	2000	2005	2010	2015	2020	2025	2030
Total Cost	8.061	0.000	0.000	6.115	3.315	#REF!	0.000	0.000	0.000

- a/ All costs assume 1990 dollars (0% annual inflation).
- b/ Computed from Capital Cost Curves (Figure VII.7).
- c/ Based on ASCE General Engineering Service Fee Curves.
- d/ Based on current estimated cost of \$5,000/acre.
- e/ Based on 3% of construction cost.
- f/ Based on 2.5% of construction cost.
- g/ Based on 2% of construction cost.
- h/ Based on 10% of construction cost.

shown in Figure VII.19 for each scenario. This amounts to \$20.14 million without water conservation and \$16.90 million with conservation.

VII.C.3.b Wastewater Collection Systems

Three Plant Scenario

As with the one plant and two plant scenarios, the three plant collection system will consist mostly of gravity sewer lines. Again, Highway 29 represents the division of flows coming in from the north and south, and the existing plant is kept at 2.5 MGD by diverting flows from basin 0 to the Mankin's Crossing plant (see Figure VII.20 and Table VII.15).

Contributing Flows South of Highway 29

Flows from basins 3a and 3b are diverted to the existing 12" Smith Branch interceptor, F', through the force main 3b'. As the Southwestern Industrial District develops, force mains leading to basins 3b and F will divert SWID flows into the Smith Branch interceptor as well.

Contributing Flows North of Highway 29

To the west, flows contributing to the existing treatment plant include Wood Ranch into 5b, 5a and 1 into 1' (which parallels an existing 10" interceptor) and 1' and 5b into 1" (which parallels an existing 12" interceptor). Line 1" contributes to 2N (2 North), which parallels the same 12" interceptor as 1" and leads to the existing treatment plant. Lines 2E (2 East) and 2W (2 West) lead to the existing treatment plant as well.

Basin E gravity flows into the eastern end of the Smith Branch interceptor, and here, a lift station and force main will pump the cumulative flows into basin D1, where gravity flow is achieved past the western ridge line. Flows from basin 0, through a series of gravity sewers and force mains, will also be diverted to basin D1 through the force main 0'.

A combination of force mains and gravity lines will pump sewage from the Far South basin into the southwest end of basin D, which gravity flows and converges with basin D1. The cumulative flows from basins D and D1 gravity flow into the Mankin's Crossing wastewater treatment plant through the line called D'.

Lines B1 and C converge to form line B1'. Lines B1' and B converge to form line B' which leads to the Berry's Creek site. Lines A and A3 lead directly to the confluence of Berry Creek with Pecan Branch.

Lines A2a and A2 converge to form line A2', which leads to line A" along the San Gabriel River. Lines A1 and A" gravity flow into the Mankin's Crossing wastewater treatment plant.

Figure VII.19
 Georgetown Regional Wastewater Planning Study
 Cumulative Treatment Cost for City of Georgetown, Berry Creek,
 and Mankin's Crossing Plants With and Without 15% Water Conservation

VII-47

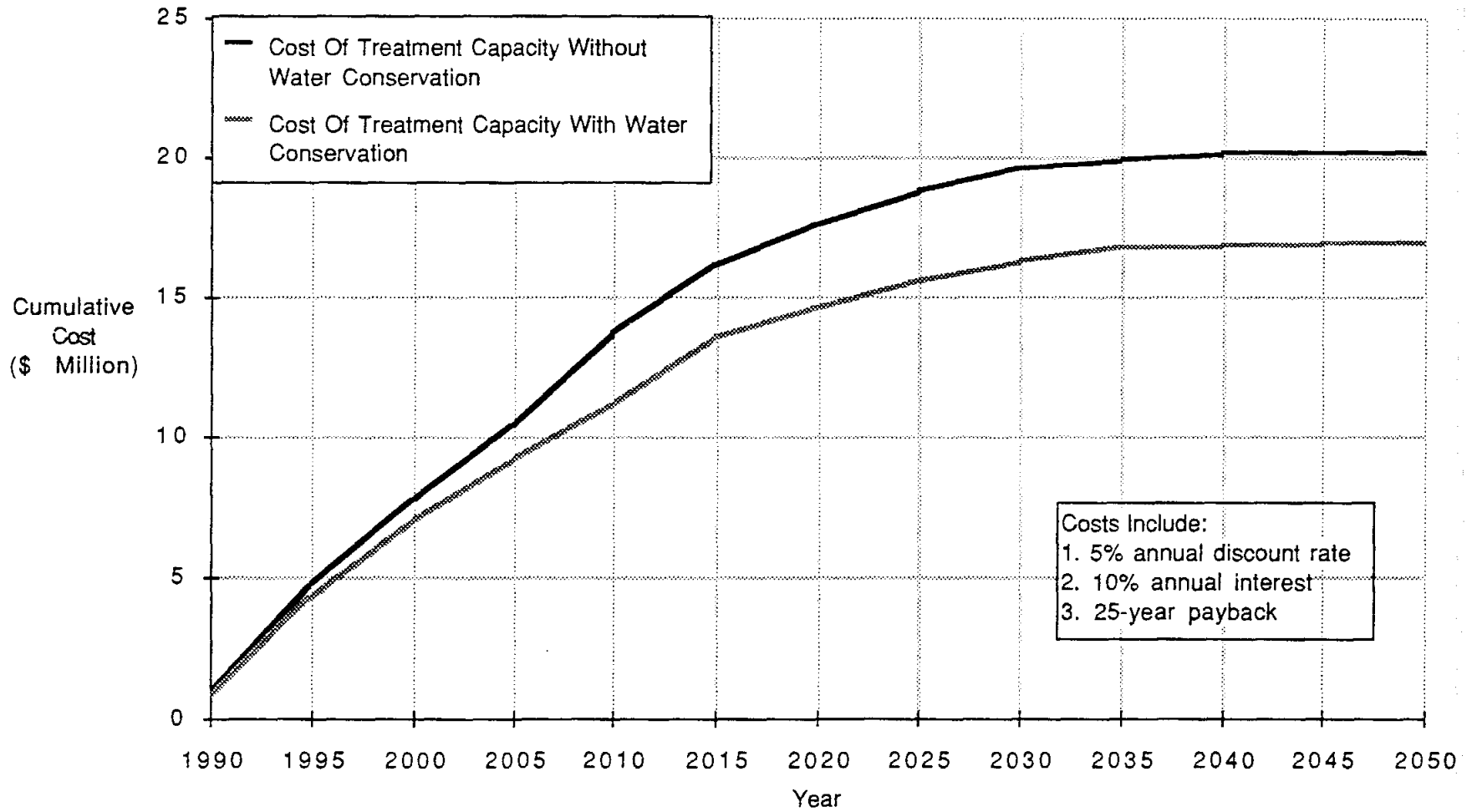

GEORGETOWN REGIONAL WASTEWATER PLANNING STUDY

BASIN	DESCRIPTION
0	Downtown (south)
1	North Fork San Gabriel
2	Downtown (north)
3a	South Fork San Gabriel
3b	South Fork San Gabriel
5a	Booty's Crossing
5b	Middle Fork San Gabriel
A	San Gabriel
B	Pecan Branch
B1	Berry Creek
D	Hankin's Branch
D1	North Hankin's Branch
E	Salth's Branch
F	I - 35 (south)
M.R.	Middle Fork San Gabriel
C	Dry Berry Creek
SWID	Industrial District
(A3)	East fork San Gabriel
F.S.	Westinghouse Road
A1	East Weir
A2	Middle Weir
A2a	West Weir

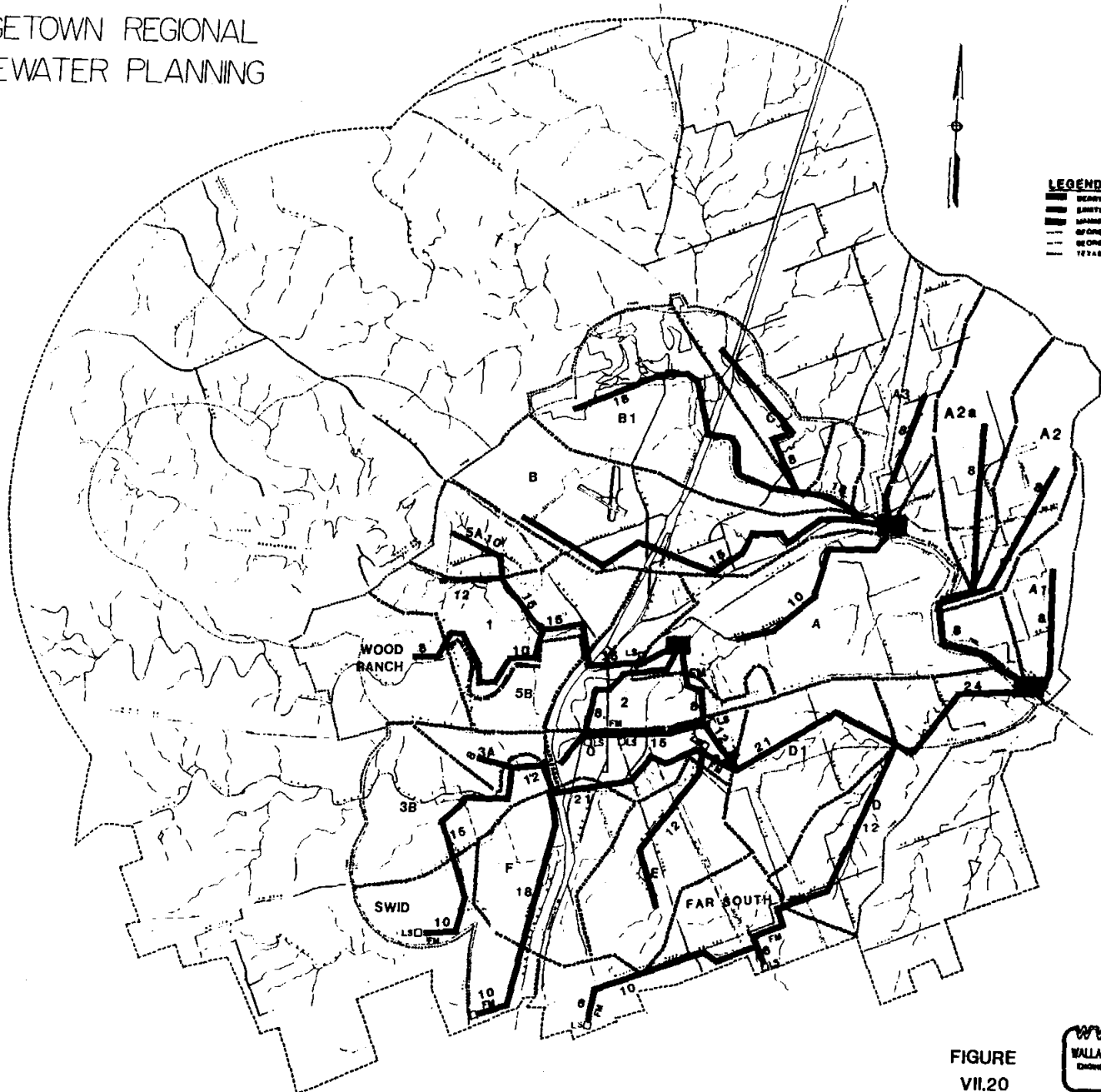

ALTERNATIVE C

FIGURE
VII.20



Table VII.15
Flows Used to Determine Pipe Sizing In Collection Systems
3 Plant Development Scenario

Interceptor	2030 Pop. Served	Contributing Areas	Total Average Daily Flows (MGD)	Peak Flow (MGD)
Mankin's Creek WWTP				
A1	151		16,610	66,440
A"		A2 + A2a	68,310	273,240
A2'		A2 + A2a	68,310	273,240
A2	314		34,540	138,160
A2a	307		33,770	135,080
A3	412		45,320	181,280
D'		D1 + D	3,903,221	9,758,053
D	541	D + FS	289,489	1,157,95
FS			229,979	919,916
D1	682	D1' + 0' + D1	3,613,732	9,034,330
D1'		3b + E + F + SWID(East)	2,406,812	7,220,436
E	3,831		459,720	1,838,880
F	4,387	F + SWID(East)	924,431	3,697,724
F'		3b' + F	1,947,092	5,841,276
(.5)SWID(East)			441,861	1,767,444
0'	10,290		1,131,900	3,395,700
0 West			565,950	2,263,800
0 East			565,950	2,263,800
3a	748		82,280	329,120
3b	4,532		498,520	1,994,080
3b'		3a + 3b + (.5)SWID(East)	1,022,661	3,067,983
(.5)SWID(West)			441,861	1,767,444
Berry Creek WWTP				
A	1,998		219,780	879,120
B'		B + B1 + C	1,520,214	4,560,642
B	5,446		626,290	2,505,160
B1'		B1 + C	893,924	3,575,696
B1	7,207		828,805	3,315,220
C			65,119	260,476
Georgetown WWTP				
2W		(.33)2	382,837	1,531,348
2E		(.33)2	382,837	1,531,348
2N		(.33)2 + 1"	1,824,387	5,473
1"		1 + 5a + 5b + WR	1,441,550	4,324,650
1'		(.66)1 + 5a	922,147	3,688,586
1	8,745	(.33)1	317,444	1,269,774
5a	2,524		277,640	1,110,560
5b	1,463	5b + WR	201,960	807,840
W.R.	373		41,030	164,120

VII.C.4 Four Plant Scenario

VII.C.4.a Wastewater Treatment Plants

Phasing of Facilities

Under the four plant scenario, it is assumed that a plant with a capacity of 1 MGD is built at Dove Springs. It would serve some of the drainage areas served by Mankin's Crossing in the three plant scenario. Tables VII.16 and VII.17 show the basins served by each plant, without water conservation and with conservation. Initially, the Dove Springs facility would serve basins O, 3b, SWID, E and F. By 1995 its capacity would be inadequate for all of these basins and flows from basin O would then be diverted to Mankin's Crossing. By 2015 the diversion of flows from basins 3b and SWID to Mankin's Crossing would also be necessary.

The phasing of the construction of each plant, together with demand projections for its service area, is shown in Figures VII.21 and VII.22. The scenarios for the Georgetown plant and the Berry Creek plant, with and without water conservation, resemble the three plant scenarios. Because the service area of the Mankin's Crossing plant is initially reduced to drainage areas D1, F.S., A1, A2, A2a and A3, the initial proposed phase is a 0.25 MGD temporary package plant. In 1995, with the addition of flows from basin O, a 1.25 MGD plant would be necessary, with a similar unit added in 2015. With water conservation, each unit could be reduced to 1.0 MGD.

Cost Estimates

Under the four plant scenario the Mankin's Crossing plant is reduced in size because of the addition of a plant at Dove Springs. Cost estimates for the Georgetown and Berry Creek plants are the same as in the three plant scenario. An initial 0.25 MGD package plant at Mankin's Crossing would cost \$0.80 million and a 1 MGD plant at Dove Springs would cost \$3.32 million. The construction of a 1.25 MGD plant at Mankin's Crossing in 1995 and again in 2015 would cost \$4.04 million (Table VII.18). With water conservation, the cost of these units would be reduced to \$3.32 million each (Table VII.19).

Cumulative costs were calculated as in the other scenarios and are shown in Figure VII.23. Total costs for all four plants discounted to present value amount to \$21.43 million without water conservation and \$19.00 million with conservation.

VII.C.4.b Wastewater Collection System

The collection system consists mostly of gravity sewer lines. However, with the addition of the Dove Springs plant, which has a small gravity service area, more lift station/force main combinations occur in this scenario. Again, Highway 29 represents the division of flows coming in from the north and south, and the

Table VII.16
Georgetown Regional Wastewater Planning Study
Wastewater Flow Projections for a City of Georgetown,
Berry Creek, Dove Springs, and Mankin's Crossing Plants

Basins Contributing to Existing City of Georgetown Facility:

Basin	Description	Projected Wastewater Flow (MGD)				
		1990	2000	2010	2020	2030
1	North Fork San Gabriel	0.339	0.456	0.666	0.794	0.962
2	Downtown (north)	0.334	0.410	0.610	0.743	1.149
5a	Booty's Crossing	0.033	0.076	0.120	0.210	0.278
5b	Middle Fork San Gabriel	0.032	0.046	0.082	0.102	0.161
W.R.	Wood Ranch	0.015	0.020	0.025	0.035	0.041
		0.753	1.008	1.503	1.884	2.591

Basins Contributing to a Berry Creek Facility:

Basin	Description	Projected Wastewater Flow (MGD)				
		1990	2000	2010	2020	2030
A	San Gabriel	0.039	0.070	0.126	0.162	0.220
B	Pecan Branch	0.178	0.266	0.362	0.471	0.626
B1	Berry Creek	0.219	0.326	0.514	0.623	0.828
C	Dry Berry Creek	0.010	0.025	0.038	0.050	0.065
		0.446	0.687	1.040	1.306	1.739

Basins Contributing to a Dove Springs Facility:

Basin	Description	Projected Wastewater Flow (MGD)				
		1990	2000	2010	2020	2030
0	Downtown (south)	0.378	0.000	0.000	0.000	0.000
3b	South Fork San Gabriel	0.138	0.203	0.289	0.000	0.000
SWID	Industrial District	0.100	0.175	0.230	0.000	0.000
E	Smith's Branch	0.033	0.069	0.145	0.304	0.460
F	I- 35 South	0.076	0.148	0.284	0.373	0.483
		0.725	0.595	0.948	0.677	0.943

Basins Contributing to a Mankin's Crossing Facility:

Basin	Description	Projected Wastewater Flow (MGD)				
		1990	2000	2010	2020	2030
0	Downtown (south)	0.000	0.568	0.825	0.916	1.132
3a	South Fork San Gabriel	0.000	0.031	0.050	0.063	0.082
3b	South Fork San Gabriel	0.000	0.000	0.000	0.394	0.499
D	Mankin's Branch	0.000	0.017	0.030	0.045	0.060
D1	North Mankin's Branch	0.014	0.021	0.036	0.049	0.075
SWID	Industrial District	0.000	0.000	0.000	0.300	0.353
F.S.	Westinghouse Road	0.075	0.100	0.150	0.195	0.230
A1	East Weir	0.004	0.007	0.010	0.013	0.017
A2	Middle Weir	0.010	0.015	0.020	0.025	0.035
A2a	West Weir	0.009	0.015	0.020	0.026	0.034
A3	East Fork San Gabriel	0.012	0.020	0.025	0.035	0.045
		0.124	0.794	1.166	2.061	2.562

Total Required Treatment Capacity:

Basin	Description	Projected Wastewater Flow (MGD)				
		1990	2000	2010	2020	2030
All	Total Wastewater Flow	2.048	3.084	4.657	5.928	7.835

Table VII.17
Georgetown Regional Wastewater Planning Study
Wastewater Flow Projections for a City of Georgetown, Dove Springs,
Berry Creek, and Mankin's Crossing Plants With 15% Water Conservation

Basins Contributing to Existing City of Georgetown Facility:

Basin	Description	Projected Wastewater Flow (MGD)				
		1990	2000	2010	2020	2030
1	North Fork San Gabriel	0.288	0.388	0.566	0.675	0.818
2	Downtown (north)	0.284	0.349	0.519	0.632	0.977
5a	Booty's Crossing	0.028	0.065	0.102	0.179	0.236
5b	Middle Fork San Gabriel	0.027	0.039	0.070	0.087	0.137
W.R.	Wood Ranch	0.013	0.017	0.021	0.030	0.035
		0.640	0.858	1.278	1.603	2.202

Basins Contributing to a Berry Creek Facility:

Basin	Description	Projected Wastewater Flow (MGD)				
		1990	2000	2010	2020	2030
A	San Gabriel	0.033	0.060	0.107	0.138	0.187
B	Pecan Branch	0.151	0.226	0.308	0.400	0.532
B1	Berry Creek	0.186	0.277	0.437	0.530	0.704
C	Dry Berry Creek	0.009	0.021	0.032	0.043	0.055
		0.379	0.584	0.884	1.111	1.478

Basins Contributing to a Dove Springs Facility:

Basin	Description	Projected Wastewater Flow (MGD)				
		1990	2000	2010	2020	2030
0	Downtown (south)	0.321	0.000	0.000	0.000	0.000
3b	South Fork San Gabriel	0.117	0.173	0.246	0.000	0.000
SWID	Industrial District	0.085	0.149	0.196	0.000	0.000
E	Smith's Branch	0.028	0.059	0.123	0.258	0.391
F	I- 35 South	0.065	0.126	0.241	0.317	0.411
		0.616	0.507	0.807	0.575	0.802

Basins Contributing to a Mankin's Crossing Facility:

Basin	Description	Projected Wastewater Flow (MGD)				
		1990	2000	2010	2020	2030
0	Downtown (south)	0.000	0.483	0.701	0.779	0.962
3a	South Fork San Gabriel	0.000	0.026	0.043	0.054	0.070
3b	South Fork San Gabriel	0.000	0.000	0.000	0.335	0.424
D	Mankin's Branch	0.000	0.014	0.026	0.038	0.051
D1	North Mankin's Branch	0.012	0.018	0.031	0.042	0.064
SWID	Industrial District	0.000	0.000	0.000	0.255	0.300
F.S.	Westinghouse Road	0.064	0.085	0.128	0.166	0.196
A1	East Weir	0.003	0.006	0.009	0.011	0.014
A2	Middle Weir	0.009	0.013	0.017	0.021	0.030
A2a	West Weir	0.008	0.013	0.017	0.022	0.029
A3	East Fork San Gabriel	0.010	0.017	0.021	0.030	0.038
		0.106	0.675	0.993	1.753	2.178

Total Required Treatment Capacity:

Basin	Description	Projected Wastewater Flow (MGD)				
		1990	2000	2010	2020	2030
All	Total Wastewater Flow	1.741	2.624	3.961	5.042	6.660

Figure VII.21
 Georgetown Regional Wastewater Planning Study
 Possible Capacity Build-out for City of Georgetown,
 Berry Creek, Dove Springs, and Mankin's Crossing Plants

VII-53

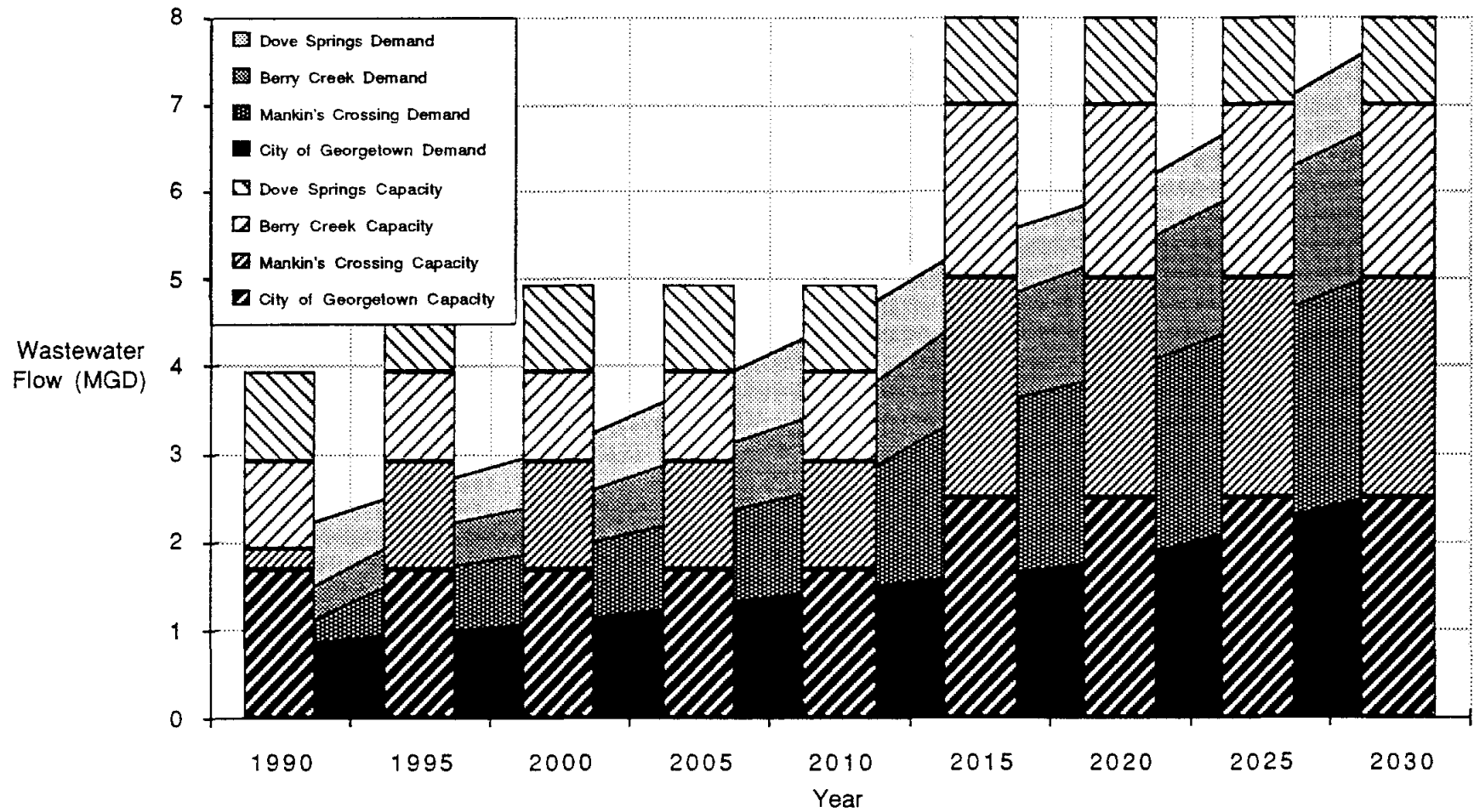

Figure VII.22
 Georgetown Regional Wastewater Planning Study
 Possible Capacity Build-out for City of Georgetown, Berry Creek,
 Dove Springs, and Mankin's Crossing Plants With 15% Water Conservation

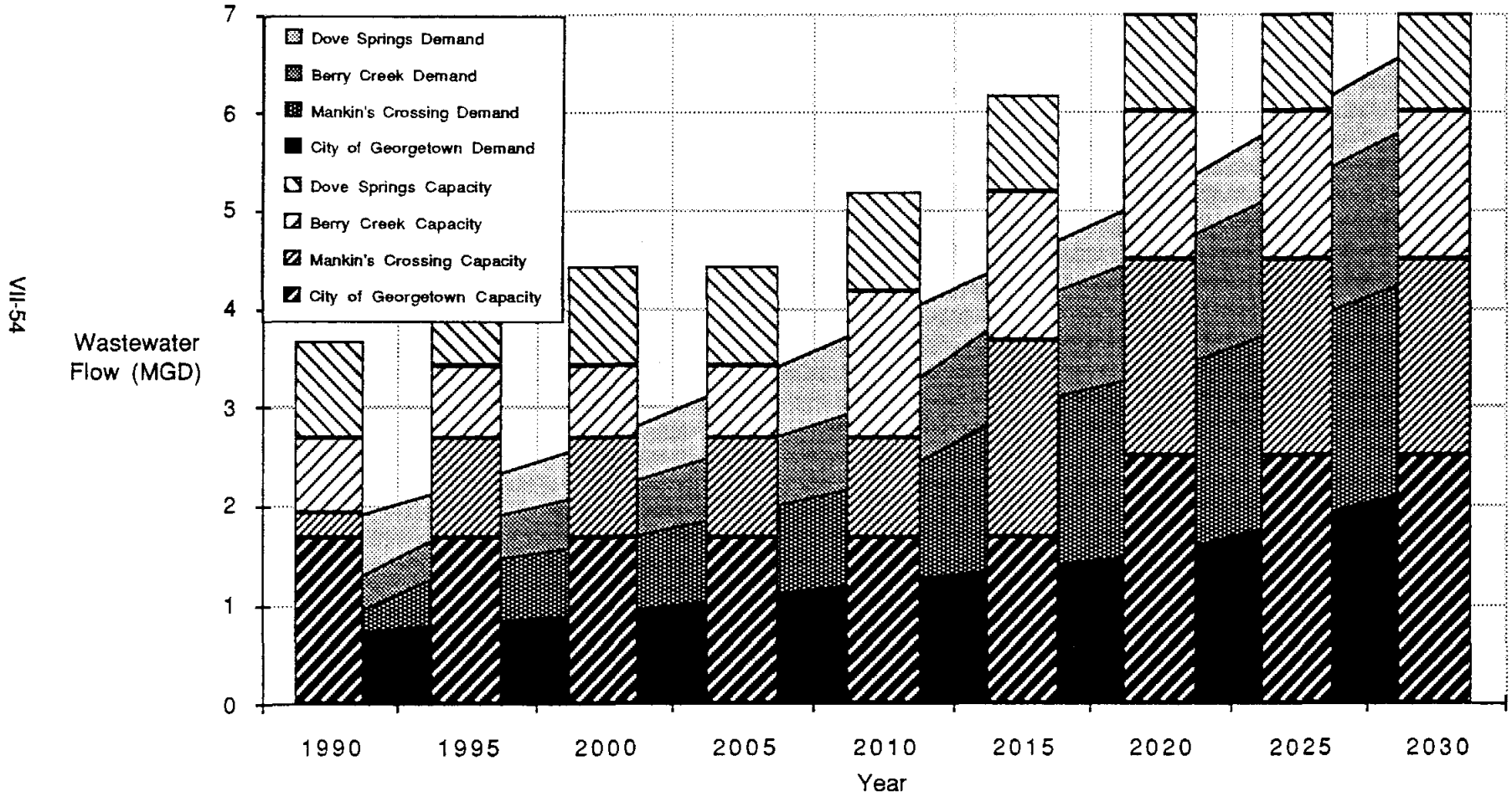

Table VII.18
 Estimated Cost of City of Georgetown, Berry Creek, Dove Springs, and Mankin's Crossing
 Wastewater Treatment Plants Without Water Conservation (1990 Through 2030) a/

Existing Georgetown Facility:

Function	Total Cost (\$ Million)									
	1990	1995	2000	2005	2010	2015	2020	2025	2030	
1. Construction Cost b/						1.000				
2. Engineering c/						0.081				
3. Land d/						0.000				
4. Surveying and Staking e/						0.030				
5. Legal and Administration f/						0.025				
6. Permitting and Fees g/						0.020				
7. Contingencies h/						0.100				
Total	0.000	0.000	0.000	0.000	0.000	1.256	0.000	0.000	0.000	

Proposed Berry Creek Facility:

Function	Total Cost (\$ Million)									
	1990	1995	2000	2005	2010	2015	2020	2025	2030	
1. Construction Cost b/	2.646					2.646				
2. Engineering c/	0.206					0.206				
3. Land d/	0.001					0.000				
4. Surveying and Staking e/	0.079					0.079				
5. Legal and Administration f/	0.066					0.066				
6. Permitting and Fees g/	0.053					0.053				
7. Contingencies h/	0.265					0.265				
Total	3.316	0.000	0.000	0.000	0.000	3.315	0.000	0.000	0.000	

Proposed Mankin's Crossing Facility:

Function	Total Cost (\$ Million)									
	1990	1995	2000	2005	2010	2015	2020	2025	2030	
1. Construction Cost b/	0.638	3.223				3.223				
2. Engineering c/	0.050	0.251				0.251				
3. Land d/	0.001	0.001				0.000				
4. Surveying and Staking e/	0.019	0.097				0.097				
5. Legal and Administration f/	0.016	0.081				0.081				
6. Permitting and Fees g/	0.013	0.064				0.064				
7. Contingencies h/	0.064	0.322				0.322				
Total	0.800	4.039	0.000	0.000	0.000	4.038	0.000	0.000	0.000	

Proposed Dove Springs Facility:

Function	Total Cost (\$ Million)									
	1990	1995	2000	2005	2010	2015	2020	2025	2030	
1. Construction Cost b/	2.647									
2. Engineering c/	0.206									
3. Land d/	0.001									
4. Surveying and Staking e/	0.079									
5. Legal and Administration f/	0.066									
6. Permitting and Fees g/	0.053									
7. Contingencies h/	0.265									
Total	3.318	0.000	0.000	0.000	0.000	0.000	0.000	0.000	0.000	

Total Projected Expenditures Without Water Conservation:

Total Cost	Total Cost (\$ Million)									
	1990	1995	2000	2005	2010	2015	2020	2025	2030	
Total Cost	7.435	4.039	0.000	0.000	0.000	8.610	0.000	0.000	0.000	

- a/ All costs assume 1990 dollars (0% annual inflation).
- b/ Computed from Capital Cost Curves (Figure VII.7).
- c/ Based on ASCE General Engineering Service Fee Curves.
- d/ Based on current estimated cost of \$5,000/acre.
- e/ Based on 3% of construction cost.
- f/ Based on 2.5% of construction cost.
- g/ Based on 2% of construction cost.
- h/ Based on 10% of construction cost.

Table VII.19
 Estimated Cost of City of Georgetown, Berry Creek, Dove Springs, and Mankin's Crossing
 Wastewater Treatment Plants With 15% Water Conservation (1990 Through 2030) a/

Existing Georgetown Facility:

Function	Total Cost (\$ Million)									
	1990	1995	2000	2005	2010	2015	2020	2025	2030	
1. Construction Cost b/							1.000			
2. Engineering c/							0.081			
3. Land d/							0.000			
4. Surveying and Staking e/							0.030			
5. Legal and Administration f/							0.025			
6. Permitting and Fees g/							0.020			
7. Contingencies h/							0.100			
Total	0.000	0.000	0.000	0.000	0.000	0.000	1.256	0.000	0.000	

Proposed Berry Creek Facility:

Function	Total Cost (\$ Million)									
	1990	1995	2000	2005	2010	2015	2020	2025	2030	
1. Construction Cost b/	2.050				2.050					
2. Engineering c/	0.160				0.160					
3. Land d/	0.001				0.001					
4. Surveying and Staking e/	0.062				0.062					
5. Legal and Administration f/	0.051				0.051					
6. Permitting and Fees g/	0.041				0.041					
7. Contingencies h/	0.205				0.205					
Total	2.570	0.000	0.000	0.000	2.570	0.000	0.000	0.000	0.000	

Proposed Mankin's Crossing Facility:

Function	Total Cost (\$ Million)									
	1990	1995	2000	2005	2010	2015	2020	2025	2030	
1. Construction Cost b/	0.638	2.646				2.646				
2. Engineering c/	0.050	0.206				0.206				
3. Land d/	0.001	0.001				0.000				
4. Surveying and Staking e/	0.019	0.079				0.079				
5. Legal and Administration f/	0.016	0.066				0.066				
6. Permitting and Fees g/	0.013	0.053				0.053				
7. Contingencies h/	0.064	0.265				0.265				
Total	0.800	3.316	0.000	0.000	0.000	3.315	0.000	0.000	0.000	

Proposed Dove Springs Facility:

Function	Total Cost (\$ Million)									
	1990	1995	2000	2005	2010	2015	2020	2025	2030	
1. Construction Cost b/	2.646									
2. Engineering c/	0.206									
3. Land d/	0.001									
4. Surveying and Staking e/	0.079									
5. Legal and Administration f/	0.066									
6. Permitting and Fees g/	0.053									
7. Contingencies h/	0.265									
Total	3.316	0.000	0.000	0.000	0.000	0.000	0.000	0.000	0.000	

Total Projected Expenditures With 15% Water Conservation:

Total Cost	Total Cost (\$ Million)									
	1990	1995	2000	2005	2010	2015	2020	2025	2030	
Total Cost	6.667	3.316	0.000	0.000	2.570	3.315	1.256	1.256	0.000	

- a/ All costs assume 1990 dollars (0% annual inflation).
- b/ Computed from Capital Cost Curves (Figure VII.7).
- c/ Based on ASCE General Engineering Service Fee Curves.
- d/ Based on current estimated cost of \$5,000/acre.
- e/ Based on 3% of construction cost.
- f/ Based on 2.5% of construction cost.
- g/ Based on 2% of construction cost.
- h/ Based on 10% of construction cost.

Figure VII.23
 Georgetown Regional Wastewater Planning Study
 Cumulative Treatment Cost for City of Georgetown, Berry Creek, Dove Springs,
 and Mankin's Crossing Plants With and Without 15% Water Conservation

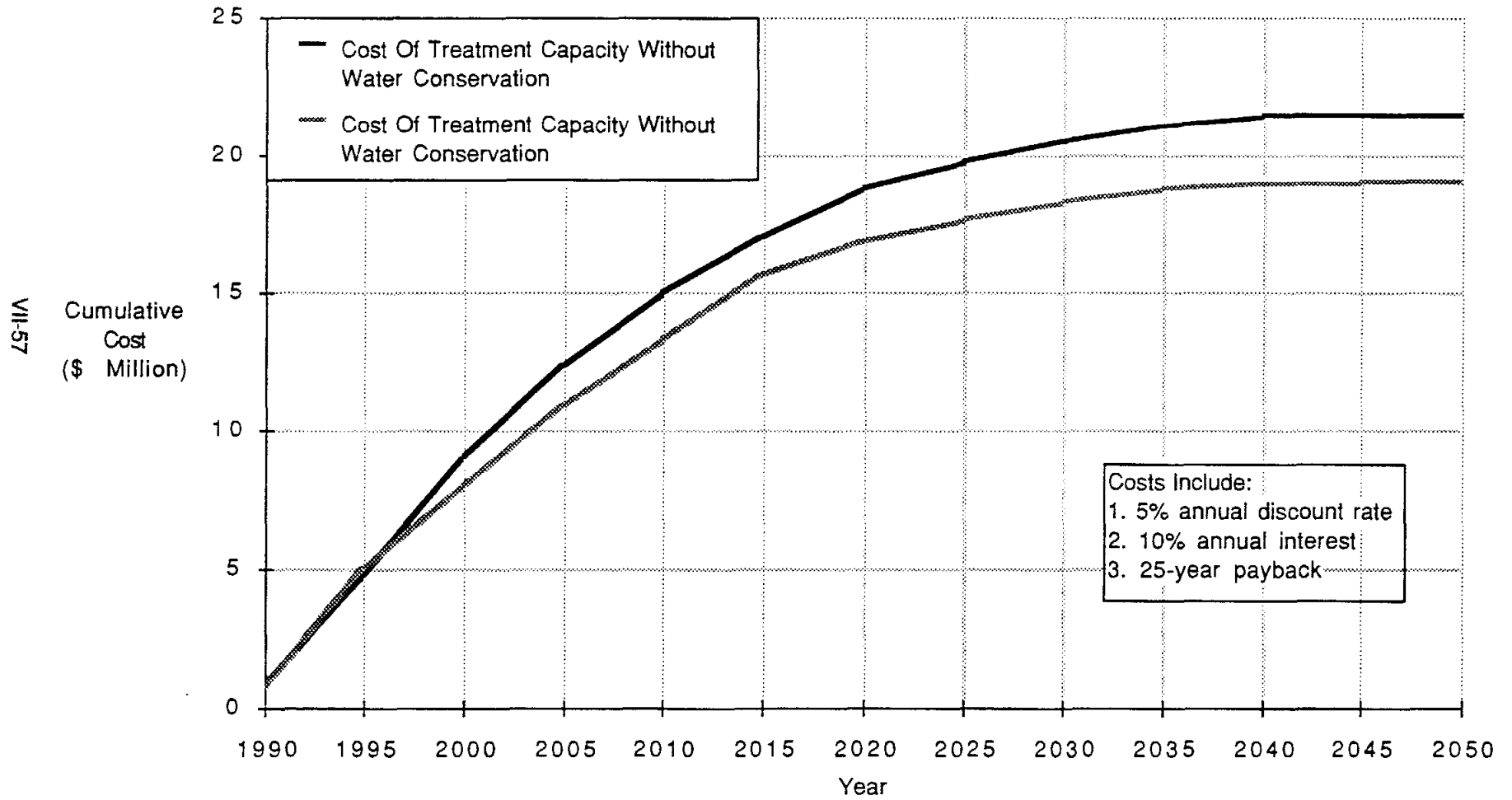

existing plant is kept at 2.5 MGD by diverting flows from basin 0 to the Dove Springs plant, and later, to the Mankin's Crossing plant (see Figure VII.24 and Table VII.20).

Contributing Flows South of Highway 29

Basins 3a and 3b are diverted to the existing 12" Smith Branch interceptor, F' through the force main 3b'. As the Southwestern Industrial District develops, force mains leading to basins 3b and F will divert SWID flows into the Smith Branch interceptor as well.

Basin E gravity flows into the eastern end of the Smith Branch interceptor, and here, a lift station and force main will pump the cumulative flows into basin D1, where gravity flow leads to the Dove Springs plant. Flows from basin 0, through a series of gravity sewers and force mains, will also be diverted to the Dove Springs plant through the force main 0'.

Because the Dove Springs plant is limited to 1.0 MGD, between the years 1990 and 2000 the flows out of basin 0 will have to be diverted to the Mankin's Crossing plant through the construction of another force main leading to a gravity sewer beyond the Dove Springs plant. In addition, between the years 2010 and 2020, the flows from 3b' will have to be diverted to the Mankin's Crossing plant.

A combination of force mains and gravity lines will pump sewage from the Far South basin into the southwest end of basin D which gravity flows and converges with the gravity line in basin D1. The cumulative flows from basins D and D1 gravity flow into the Mankin's Crossing wastewater treatment plant through the line called D'.

Contributing Flows North of Highway 29

North of Highway all future collection system details are the same as described in the three plant scenario.

VII.C.5 Two Stage Scenario

VII.C.5.a Wastewater Treatment Plants

Phasing of Facilities

Under this scenario the same sites as those utilized in the four plant scenario are employed. However, by limiting the service area and installing temporary package treatment plants in the initial stage, considerable capital cost savings can be realized. Initially, 1.2 MGD package plants are located at Dove Springs and at Berry Creek. The basins served by these plants are shown in Tables VII.21 and VII.22 and resemble those in the four plant scenario; no service is provided to D1, the Far South and the Weir basins. By the year 2000, the capacity of the Dove Springs plant would be exceeded and a 2.8 MGD plant would be neces-

GEORGETOWN REGIONAL WASTEWATER PLANNING STUDY

BASIN	DESCRIPTION
0	Downtown (south)
1	North Fork San Gabriel
2	Downtown (north)
3a	South Fork San Gabriel
3b	South Fork San Gabriel
5a	Booty's Crossing
5b	Middle Fork San Gabriel
A	San Gabriel
B	Pecan Branch
B1	Berry Creek
D	Mankin's Branch
D1	North Mankin's Branch
E	Smith's Branch
F	1 - 35 (south)
U.K.	Middle Fork San Gabriel
C	Dry Berry Creek
SWID	Industrial District
(A3)	East Fork San Gabriel
F.S.	Westinghouse Road
A1	East Weir
A2	Middle Weir
A2a	West Weir

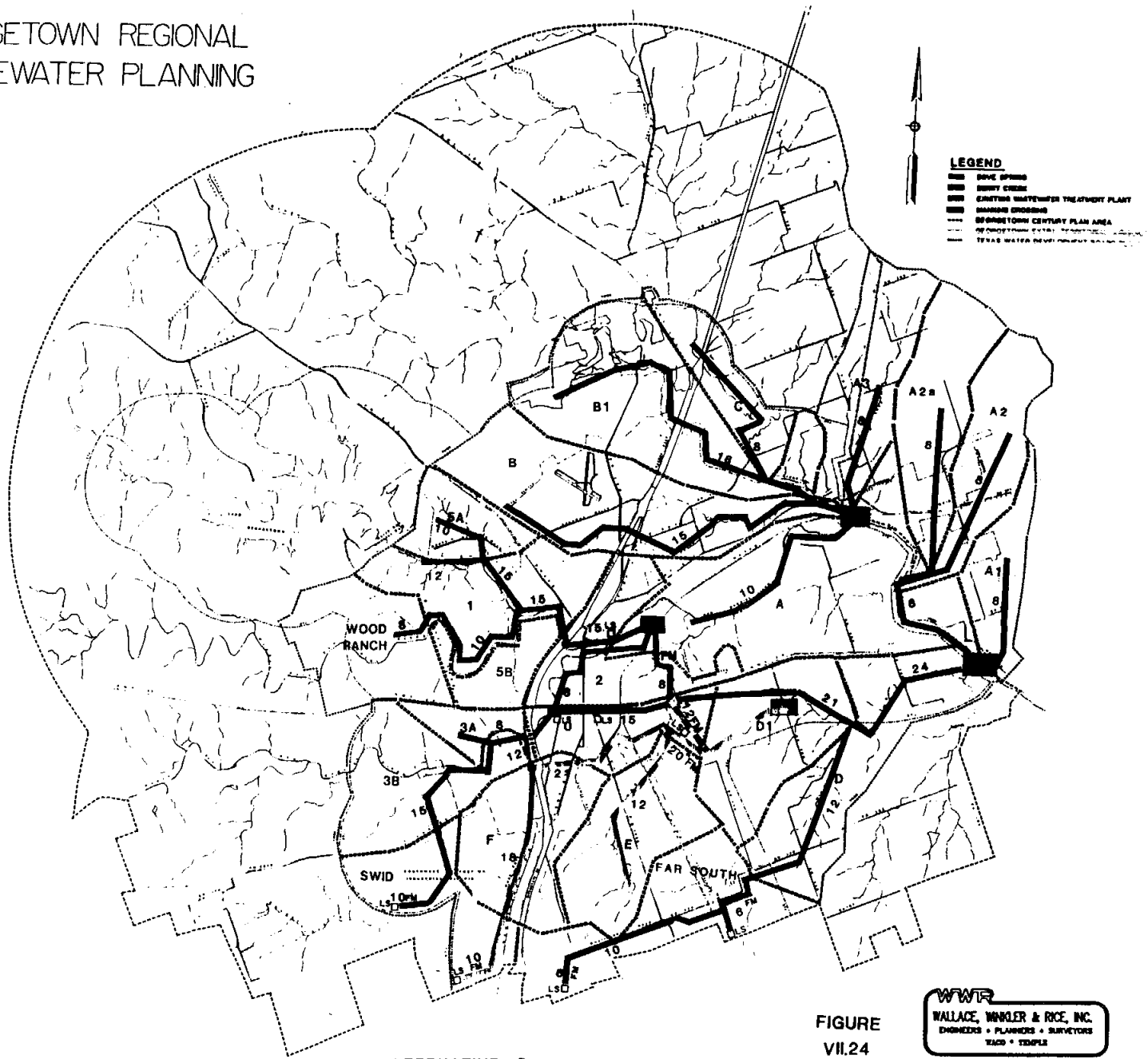

ALTERNATIVE D

FIGURE
VII.24

WWR
WALLACE, WINKLER & RICE, INC.
ENGINEERS • PLANNERS • SURVEYORS
TACD • TEMPER

Table VII.20
Flows Used to Determine Pipe Sizing in Collection Systems
4 Plant Development Scenario

Interceptor	2030 Pop. Served	Contributing Areas	Total Average Daily Flows (MGD)	Peak Flow (MGD)
Mankin's Crossing Plus Dove Springs WWTPs				
A1	151		16,610	66,440
A"		A2 + A2a	68,310	273,240
A2'		A2 + A2a	68,310	273,240
A2	314		34,540	138,160
A2a	307		33,770	135,080
A3	412		45,320	181,280
D'		(.67)D1 + 0' + D	2,494,063	6,235,158
D	541	D + FS	289,489	1,157,95
FS			229,979	919,916
D1	682	D' + (.3)D1	1,409,157	4,227,472
D1'		E + F	1,384,151	4,152,453
E	3,831		459,720	1,838,880
F	4,387	F + SWID(East)	924,431	3,697,724
F'		Parallel SB	924,431	3,697,724
(.5)SWID(East)			441,861	1,767,444
0'	10,290	0East + 0West	2,154,561	5,386,403
0 West		3a + 3b + (.5)0	1,588,611	4,765,833
0 East			565,950	2,263,800
3a	748		82,280	329,120
3b	4,532		498,520	1,994,080
3b'				
(.5)SWID(West)			441,861	1,767,444
Berry Creek WWTP				
A	1,998		219,780	879,120
B'		B + B1 + C	1,520,214	4,560,642
B	5,446		626,290	2,505,160
B1'		B1 + C	893,924	3,575,696
B1	7,207		828,805	3,315,220
C			65,119	260,476
Georgetown WWTP				
2W		(.33)2	382,837	1,531,348
2E		(.33)2	382,837	1,531,348
2N		(.33)2 + 1"	1,824,387	5,473
1"		1 + 5a + 5b + WR	1,441,550	4,324,650
1'		(.66)1 + 5a	922,147	3,688,586
1	8,745		317,444	1,269,774
5a	2,524		277,640	1,110,560
5b	1,463	5b + WR	201,960	807,840
W.R.	373		41,030	164,120

Table VII.21
Georgetown Regional Wastewater Planning Study
Wastewater Flow Projections for a City of Georgetown, Berry
Creek, Dove Springs, and Mankin's Crossing Plants, Built in Two Stages

Basins Contributing to Existing City of Georgetown Facility:

Basin	Description	Projected Wastewater Flow (MGD)				
		1990	2000	2010	2020	2030
1	North Fork San Gabriel	0.339	0.456	0.666	0.794	0.962
2	Downtown (north)	0.334	0.410	0.610	0.743	1.149
5a	Booty's Crossing	0.033	0.076	0.120	0.210	0.278
5b	Middle Fork San Gabriel	0.032	0.046	0.082	0.102	0.161
W.R.	Wood Ranch	0.015	0.020	0.025	0.035	0.041
		0.753	1.008	1.503	1.884	2.591

Basins Contributing to a Berry Creek Facility:

Basin	Description	Projected Wastewater Flow (MGD)				
		1990	2000	2010	2020	2030
A	San Gabriel	0.039	0.070	0.000	0.000	0.000
B	Pecan Branch	0.178	0.266	0.000	0.000	0.000
B1	Berry Creek	0.219	0.326	0.000	0.000	0.000
C	Dry Berry Creek	0.010	0.025	0.000	0.000	0.000
		0.446	0.687	0.000	0.000	0.000

Basins Contributing to a Dove Springs Facility:

Basin	Description	Projected Wastewater Flow (MGD)				
		1990	2000	2010	2020	2030
0	Downtown (south)	0.378	0.000	0.000	0.000	0.000
3b	South Fork San Gabriel	0.138	0.000	0.000	0.000	0.000
SWID	Industrial District	0.100	0.000	0.000	0.000	0.000
E	Smith's Branch	0.033	0.000	0.000	0.000	0.000
F	I - 35 South	0.076	0.000	0.000	0.000	0.000
		0.725	0	0	0	0

Basins Contributing to a Mankin's Crossing Facility:

Basin	Description	Projected Wastewater Flow (MGD)				
		1990	2000	2010	2020	2030
0	Downtown (south)	0.000	0.568	0.825	0.916	1.132
3a	South Fork San Gabriel	0.000	0.031	0.050	0.063	0.082
3b	South Fork San Gabriel	0.000	0.203	0.289	0.394	0.499
A	San Gabriel	0.000	0.000	0.126	0.162	0.220
B	Pecan Branch	0.000	0.000	0.362	0.471	0.626
B1	Berry Creek	0.000	0.000	0.514	0.623	0.828
C	Dry Berry Creek	0.000	0.000	0.038	0.050	0.065
D	Mankin's Branch	0.000	0.017	0.030	0.045	0.060
D1	North Mankin's Branch	0.000	0.021	0.036	0.049	0.075
E	Smith's Branch	0.000	0.069	0.145	0.304	0.460
F	I - 35 South	0.000	0.148	0.284	0.373	0.483
SWID	Industrial District	0.000	0.175	0.230	0.300	0.353
F.S.	Westinghouse Road	0.000	0.100	0.150	0.195	0.230
A1	East Weir	0.000	0.007	0.010	0.013	0.017
A2	Middle Weir	0.000	0.015	0.020	0.025	0.035
A2a	West Weir	0.000	0.015	0.020	0.026	0.034
A3	East Fork San Gabriel	0.000	0.020	0.025	0.035	0.045
		0.000	1.389	3.154	4.044	5.244

Total Required Treatment Capacity:

Basin	Description	Projected Wastewater Flow (MGD)				
		1990	2000	2010	2020	2030
All	Total Wastewater Flow	1.924	3.084	4.657	5.928	7.835

Table VII.22
Georgetown Regional Wastewater Planning Study Wastewater
Flow Projections for a City of Georgetown, Dove Springs, Berry Creek
and Mankin's Crossing Plants, Built In Two Stages With 15% Water Conservation

Basins Contributing to Existing City of Georgetown Facility:

Basin	Description	Projected Wastewater Flow (MGD)				
		1990	2000	2010	2020	2030
1	North Fork San Gabriel	0.288	0.388	0.566	0.675	0.818
2	Downtown (north)	0.284	0.349	0.519	0.632	0.977
5a	Booty's Crossing	0.028	0.065	0.102	0.179	0.236
5b	Middle Fork San Gabriel	0.027	0.039	0.070	0.087	0.137
W.R.	Wood Ranch	0.013	0.017	0.021	0.030	0.035
		0.640	0.858	1.278	1.603	2.202

Basins Contributing to a Berry Creek Facility:

Basin	Description	Projected Wastewater Flow (MGD)				
		1990	2000	2010	2020	2030
A	San Gabriel	0.033	0.060	0.107	0.000	0.000
B	Pecan Branch	0.151	0.226	0.308	0.000	0.000
B1	Berry Creek	0.186	0.277	0.437	0.000	0.000
C	Dry Berry Creek	0.009	0.021	0.032	0.000	0.000
		0.379	0.584	0.884	0.000	0.000

Basins Contributing to a Dove Springs Facility:

Basin	Description	Projected Wastewater Flow (MGD)				
		1990	2000	2010	2020	2030
0	Downtown (south)	0.321	0.483	0.000	0.000	0.000
3b	South Fork San Gabriel	0.117	0.173	0.000	0.000	0.000
SWID	Industrial District	0.085	0.149	0.000	0.000	0.000
E	Smith's Branch	0.028	0.059	0.000	0.000	0.000
F	I - 35 South	0.065	0.126	0.000	0.000	0.000
		0.616	0.990	0.000	0.000	0.000

Basins Contributing to a Mankin's Crossing Facility:

Basin	Description	Projected Wastewater Flow (MGD)				
		1990	2000	2010	2020	2030
0	Downtown (south)	0.000	0.000	0.701	0.779	0.962
3a	South Fork San Gabriel	0.000	0.000	0.043	0.054	0.070
3b	South Fork San Gabriel	0.000	0.000	0.246	0.335	0.424
A	San Gabriel	0.000	0.000	0.000	0.138	0.187
B	Pecan Branch	0.000	0.000	0.000	0.400	0.532
B1	Berry Creek	0.000	0.000	0.000	0.530	0.704
C	Dry Berry Creek	0.000	0.000	0.000	0.043	0.055
D	Mankin's Branch	0.000	0.000	0.026	0.038	0.051
D1	North Mankin's Branch	0.000	0.000	0.031	0.042	0.064
E	Smith's Branch	0.000	0.000	0.123	0.258	0.391
F	I - 35 South	0.000	0.000	0.241	0.317	0.411
SWID	Industrial District	0.000	0.000	0.196	0.255	0.300
F.S.	Westinghouse Road	0.000	0.000	0.128	0.166	0.196
A1	East Weir	0.000	0.000	0.009	0.011	0.014
A2	Middle Weir	0.000	0.000	0.017	0.021	0.030
A2a	West Weir	0.000	0.000	0.017	0.022	0.029
A3	East Fork San Gabriel	0.000	0.000	0.021	0.030	0.038
		0.000	0.000	1.799	3.439	4.458

Total Required Treatment Capacity:

Basin	Description	Projected Wastewater Flow (MGD)				
		1990	2000	2010	2020	2030
All	Total Wastewater Flow	1.635	2.432	3.961	5.042	6.660

sary at Mankin's Crossing to serve all of the basins south of SH 29 plus Weir. The Berry Creek plant would be adequate until 2010, at which time it would be abandoned and the flows from the Berry Creek watershed would be diverted to Mankin's Crossing. This would necessitate an increase in the capacity of this plant to 4.15 MGD. The addition of another similar unit in 2020 would increase its capacity to 5.5 MGD to accommodate all of the flows for the duration of the planning period.

With water conservation, the Dove Springs plant would be adequate until 2005 and a plant at Mankin's Crossing would not have to be built until this time. The life of the Berry Creek plant could also be extended an additional five years. The Mankin's Crossing plant would have a total capacity of 4.5 MGD by the end of the planning horizon. The phasing of the construction of each plant, together with demand projections for its service area, is shown in Figures VII.25 and VII.26.

Cost Estimates

Under the two stage scenario many of the capital costs incurred in the previous scenarios are deferred. As in the previously described scenarios, considerable cost savings can be realized by modifying the operation of the existing Georgetown wastewater treatment facility to achieve nitrification versus an immediate upgrade at existing or permitted conditions. However, immediate provisions must be made to accommodate current development southeast of Georgetown in the vicinity of the Dove Springs subdivision. The Dove Springs Development Corporation has a TWC permit to construct and operate a 0.250 MGD package plant.

The City of Georgetown has the opportunity to purchase one or more used 1.2 MGD package plants. The incremental cost of site preparation for a 1.0-1.2 MGD treatment plant versus a 0.250 MGD treatment plant is, relatively, insignificant. Georgetown's wastewater department staff have prepared detailed cost estimates based on the purchase of two used 1.0-1.2 MGD package plant at current market values. Estimated costs for used package plants range from \$40,000 to \$100,000. Construction of a site pad and access roads, provision of electric service and ancillary equipment is estimated at less than \$900,000. The major cost associated with the unloading and modified operation of the existing Georgetown facility is for a lift-station to transfer the wastewater over the basin boundary.

The initial cost estimates include two temporary package plants for a total outlay of \$2 million. In the year 2000 a 2.8 MGD plant at Mankin's Crossing would cost \$8.23 million with a \$4.32 million unit added in 2010 and again in 2020 (plus the cost of upgrading the existing facility)(Table VII.23). With water conservation, additional deferment of expenditure would be possible, with a 3 MGD plant built at Mankin's Crossing in 2005 at a cost of \$8.77 million. Another 1.5 MGD of capacity would cost \$4.75 million in 2015 (Table VII.24).

Figure VII.25
 Georgetown Regional Wastewater Planning Study
 Possible Capacity Build-out for City of Georgetown, Berry Creek,
 Dove Springs, and Mankin's Crossing Plants Built in Two Stages

VII-64

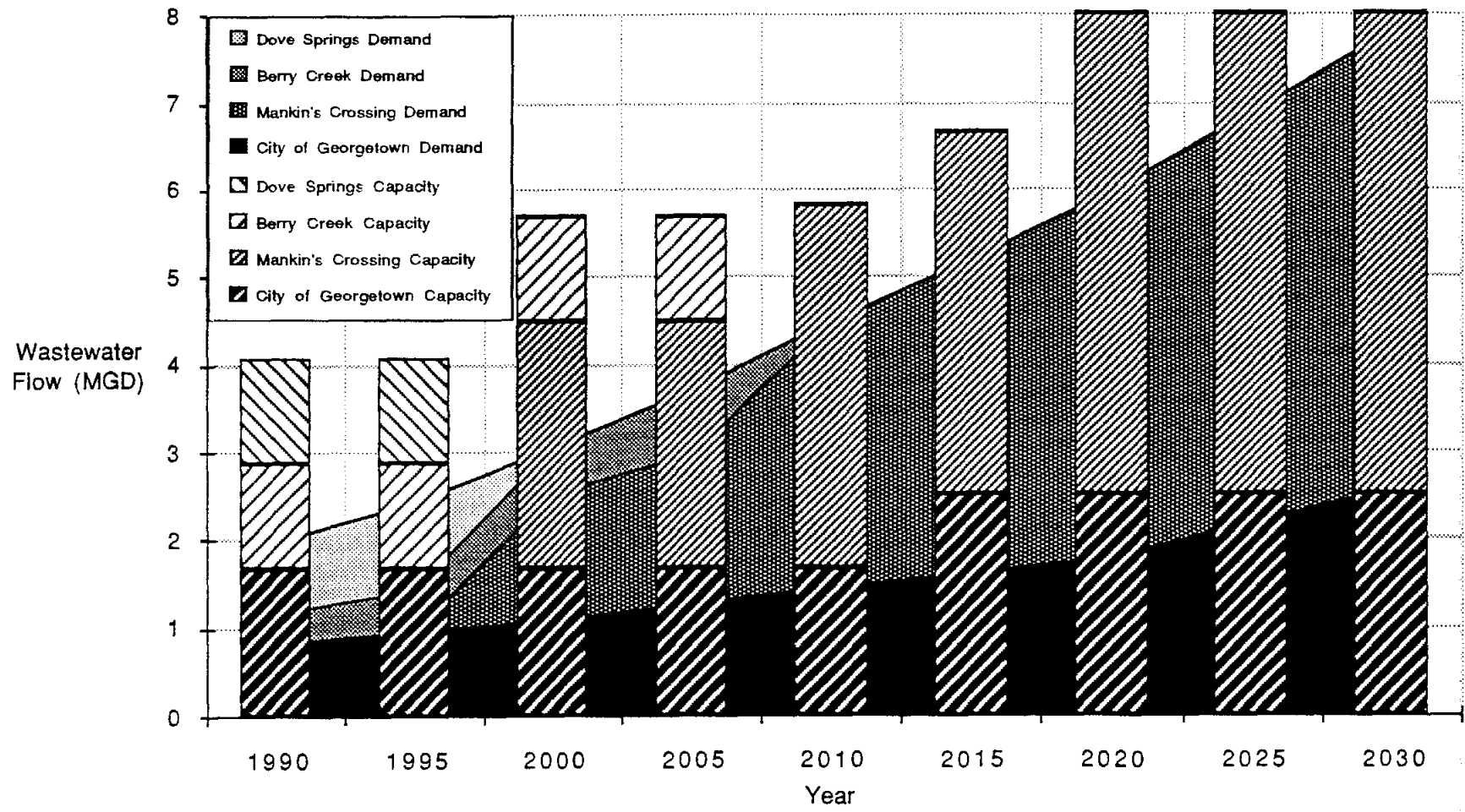
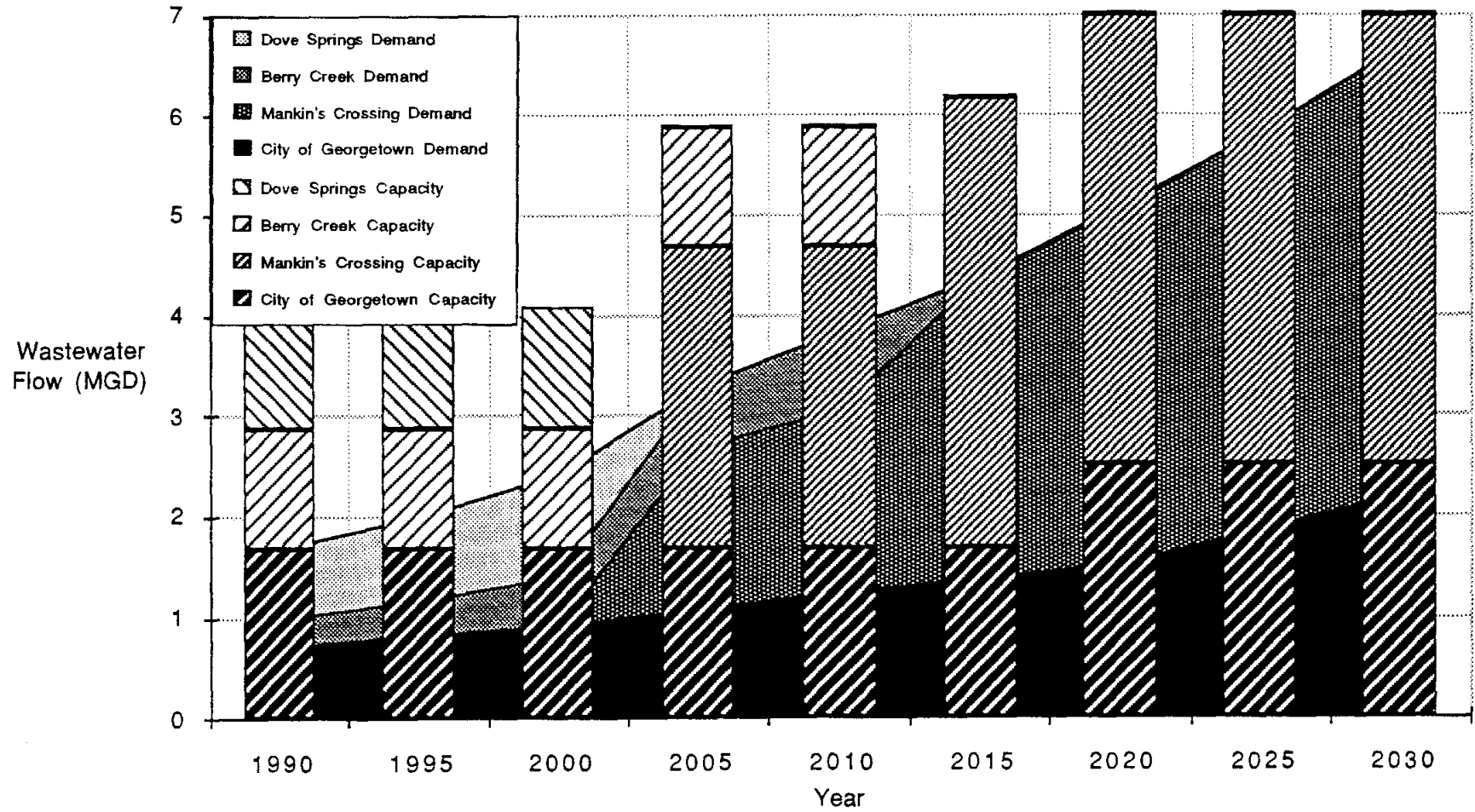

Figure VII.26
 Georgetown Regional Wastewater Planning Study
 Possible Capacity Build-out for City of Georgetown, Berry Creek,
 Dove Springs, and Mankin's Crossing Plants With 15% Water Conservation Built in Two Stages



VII-65

Table VII.23
 Estimated Cost of City of Georgetown, Berry Creek, Dove Springs, and Mankin's Crossing
 Wastewater Treatment Plants Built in Two Stages Without Water Conservation (1990 Through 2030) a/

Existing Georgetown Facility:

Function	Total Cost (\$ Million)									
	1990	1995	2000	2005	2010	2015	2020	2025	2030	
1. Construction Cost b/						1.000				
2. Engineering c/						0.081				
3. Land d/						0.000				
4. Surveying and Staking e/						0.030				
5. Legal and Administration f/						0.025				
6. Permitting and Fees g/						0.020				
7. Contingencies h/						0.100				
Total	0.000	0.000	0.000	0.000	0.000	1.256	0.000	0.000	0.000	

Proposed Berry Creek Facility:

Function	Total Cost (\$ Million)									
	1990	1995	2000	2005	2010	2015	2020	2025	2030	
1. Construction Cost b/										
2. Engineering c/										
3. Land d/										
4. Surveying and Staking e/										
5. Legal and Administration f/										
6. Permitting and Fees g/										
7. Contingencies h/										
Total	1.000	0.000	0.000	0.000	0.000	0.000	0.000	0.000	0.000	

Proposed Mankin's Crossing Facility:

Function	Total Cost (\$ Million)									
	1990	1995	2000	2005	2010	2015	2020	2025	2030	
1. Construction Cost b/			6.570		3.450		3.450			
2. Engineering c/			0.512		0.269		0.269			
3. Land d/			0.001		0.000		0.000			
4. Surveying and Staking e/			0.197		0.104		0.104			
5. Legal and Administration f/			0.164		0.086		0.086			
6. Permitting and Fees g/			0.131		0.069		0.069			
7. Contingencies h/			0.657		0.345		0.345			
Total	0.000	0.000	8.233	0.000	4.323	0.000	4.323	0.000	0.000	

Proposed Dove Springs Facility:

Function	Total Cost (\$ Million)									
	1990	1995	2000	2005	2010	2015	2020	2025	2030	
1. Construction Cost b/										
2. Engineering c/										
3. Land d/										
4. Surveying and Staking e/										
5. Legal and Administration f/										
6. Permitting and Fees g/										
7. Contingencies h/										
Total	1.000	0.000	0.000	0.000	0.000	0.000	0.000	0.000	0.000	

Total Projected Expenditures Without Water Conservation:

	Total Cost (\$ Million)									
	1990	1995	2000	2005	2010	2015	2020	2025	2030	
Total Cost	2.000	0.000	8.233	0.000	4.323	1.256	4.323	0.000	0.000	

- a/ All costs assume 1990 dollars (0% annual inflation).
- b/ Computed from Capital Cost Curves (Figure VII.7).
- c/ Based on ASCE General Engineering Service Fee Curves.
- d/ Based on current estimated cost of \$5,000/acre.
- e/ Based on 3% of construction cost.
- f/ Based on 2.5% of construction cost.
- g/ Based on 2% of construction cost.
- h/ Based on 10% of construction cost.

Table VII.24
 Estimated Cost of City of Georgetown, Berry Creek, Dove Springs, and Mankin's Crossing
 Wastewater Treatment Plants Built in Two Stages With 15% Water Conservation (1990 Through 2030) a/

Existing Georgetown Facility:

Function	Total Cost (\$ Million)								
	1990	1995	2000	2005	2010	2015	2020	2025	2030
1. Construction Cost b/							1.000		
2. Engineering c/							0.081		
3. Land d/							0.000		
4. Surveying and Staking e/							0.030		
5. Legal and Administration f/							0.025		
6. Permitting and Fees g/							0.020		
7. Contingencies h/							0.100		
Total	0.000	0.000	0.000	0.000	0.000	0.000	1.256	0.000	0.000

Proposed Berry Creek Facility:

Function	Total Cost (\$ Million)								
	1990	1995	2000	2005	2010	2015	2020	2025	2030
1. Construction Cost b/									
2. Engineering c/									
3. Land d/									
4. Surveying and Staking e/									
5. Legal and Administration f/									
6. Permitting and Fees g/									
7. Contingencies h/									
Total	1.000	0.000	0.000	0.000	0.000	0.000	0.000	0.000	0.000

Proposed Mankin's Crossing Facility:

Function	Total Cost (\$ Million)								
	1990	1995	2000	2005	2010	2015	2020	2025	2030
1. Construction Cost b/				7.000		3.790			
2. Engineering c/				0.546		0.296			
3. Land d/				0.001		0.000			
4. Surveying and Staking e/				0.210		0.114			
5. Legal and Administration f/				0.175		0.095			
6. Permitting and Fees g/				0.140		0.076			
7. Contingencies h/				0.700		0.379			
Total	0.000	0.000	0.000	8.772	0.000	4.749	0.000	0.000	0.000

Proposed Dove Springs Facility:

Function	Total Cost (\$ Million)								
	1990	1995	2000	2005	2010	2015	2020	2025	2030
1. Construction Cost b/									
2. Engineering c/									
3. Land d/									
4. Surveying and Staking e/									
5. Legal and Administration f/									
6. Permitting and Fees g/									
7. Contingencies h/									
Total	1.000	0.000	0.000	0.000	0.000	0.000	0.000	0.000	0.000

Total Projected Expenditures With 15% Water Conservation:

Total Cost	Total Cost (\$ Million)								
	1990	1995	2000	2005	2010	2015	2020	2025	2030
Total Cost	2.000	0.000	0.000	8.772	0.000	4.749	1.256	1.256	0.000

- a/ All costs assume 1990 dollars (0% annual inflation).
- b/ Computed from Capital Cost Curves (Figure VII.7).
- c/ Based on ASCE General Engineering Service Fee Curves.
- d/ Based on current estimated cost of \$5,000/acre.
- e/ Based on 3% of construction cost.
- f/ Based on 2.5% of construction cost.
- g/ Based on 2% of construction cost.
- h/ Based on 10% of construction cost.

Cumulative costs were calculated as in the other scenarios and are shown in Figure VII.27. Total costs for all four plants discounted to present value amount to \$16.99 million without water conservation and \$12.96 million with conservation.

Present-worth economic analyses are partially designed to emphasize the time-value of money. Delaying expenditures necessary to upgrade the existing Georgetown facility will have a lower present-worth, especially if a 8-7/8% discount rate (as recommended by the TWDB) is used, than an immediate plant upgrade. Even without this added economic justification, operational modification of the existing plant, at a minor cost, and the flexibility afforded by the two interim plant scenario stands on its own merits.

VII.C.5.b Wastewater Collection System

In order to accommodate flows to all of the plants in both stages of this scenario, the layout of the collection system is the same as for the four plant scenario.

VII.C.6 Comparison of Costs for Each Scenario

Figure VII.28 shows the costs for the construction of WWTPs under each of the scenarios described in the previous sections. Clearly, the one plant scenario is the most expensive and the two stage scenario is cheapest. For the other three scenarios, cost increases as a function of the number of plants built. The implementation of a water conservation plan would also result in considerable cost savings, primarily as a result of deferring capital expenditures.

The cost of the collector system in each scenario is shown in Table VII.25 and Figure VII.29. In this case, there is less difference in the cost of each scenario. Additional costs associated with the one and two plant scenario are incurred as a result of needed large interceptors to divert flows from both the Berry Creek watershed and the southern part of the planning area to Mankin's Crossing. No attempt has been made to determine when each interceptor will be built and this has the effect of inflating these costs relative to those estimated for the WWTPs. In fact, several of the larger interceptors would not be built until construction of the Mankin's Crossing plant is completed, a delay of at least ten years in the two stage scenario.

Figure VII.27
 Georgetown Regional Wastewater Planning Study
 Cumulative Treatment Cost for City of Georgetown, Berry Creek, Dove Springs,
 and Mankin's Crossing Plants With and Without 15% Water Conservation

69-11A

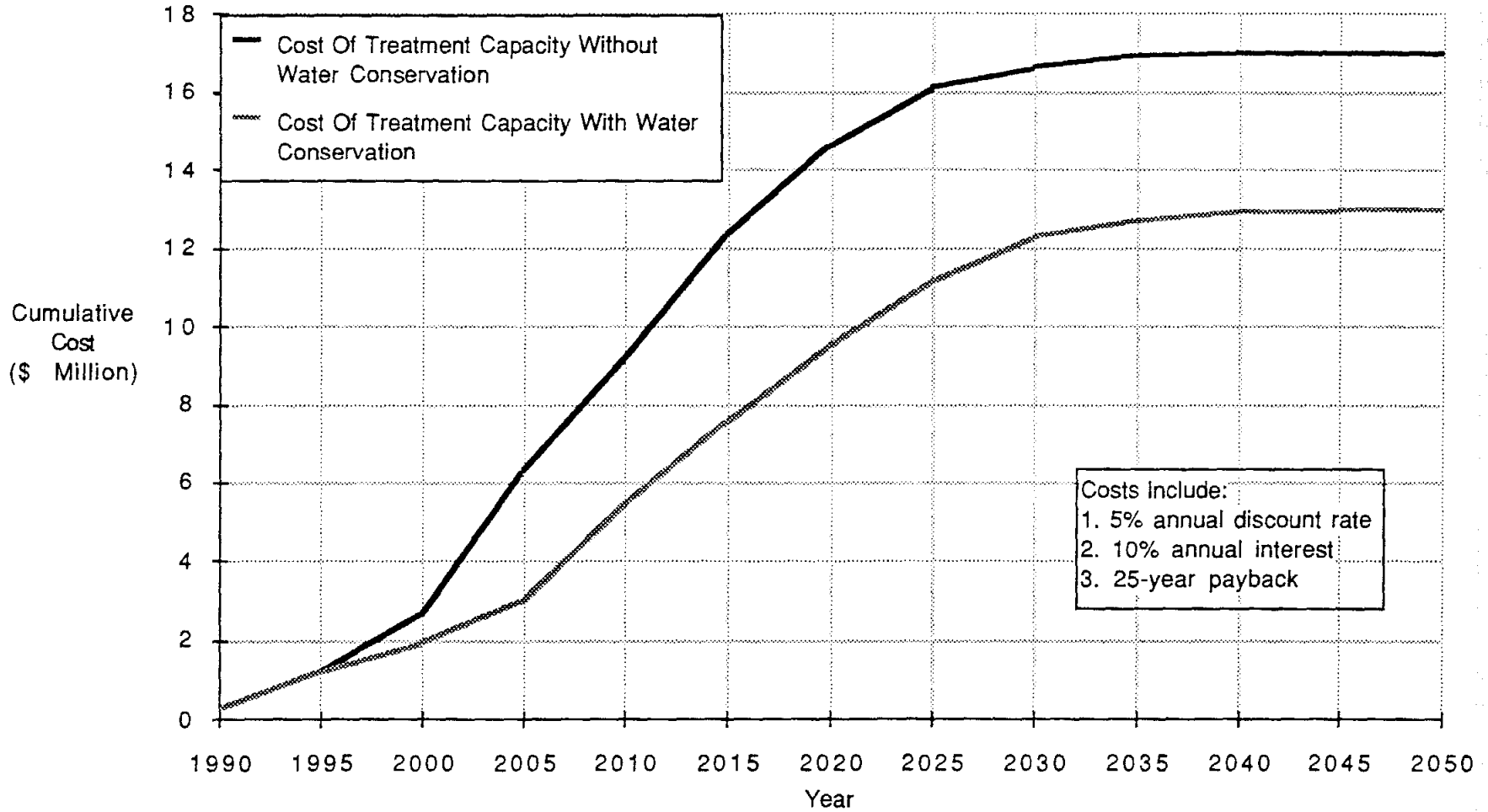
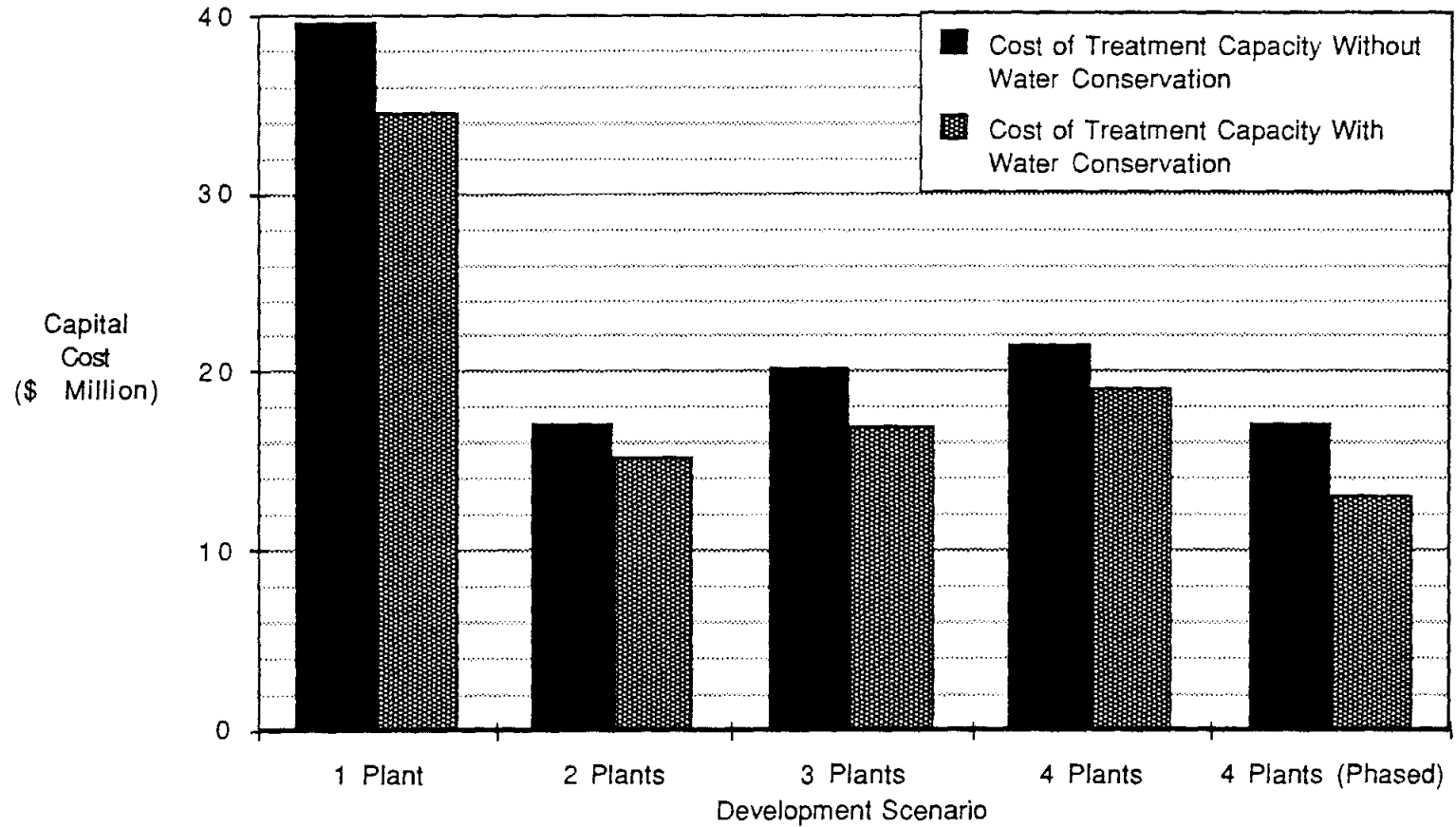

Figure VII.28
 Georgetown Regional Wastewater Planning Study
 Cost of Treatment Capacity With and Without 15% Water Conservation



VII-70

Table VII.25
Capital Costs for Collection Systems a/ b/ c/

Interceptor	One Plant	Two Plant	Three Plant	Four Plant
0(east)	143,700	344,950	344,950	344,950
0(west)	0	361,050	361,050	461,150
0'	0	112,500	112,500	165,000
1'	219,500	219,500	219,500	219,500
1	125,600	125,600	125,600	125,600
1"	440,500	440,500	440,500	440,500
2W	378,575	179,075	179,075	179,075
2E	101,790	101,790	101,790	101,790
2N	111,400	111,400	111,400	111,400
3a	130,050	130,050	130,050	130,050
3b	423,700	423,700	423,700	423,700
3b'	162,500	162,500	162,500	N/A
5a	123,600	123,600	123,600	123,600
5b	313,250	313,250	313,250	313,250
A	955,920	384,720	384,720	384,720
A'	460,790	340,090	N/A	N/A
A"	746,350	550,850	217,350	217,350
B	1,257,500	1,257,500	1,257,500	1,257,500
B'	139,650	139,650	139,650	139,650
B1	854,410	854,410	854,410	854,410
B1'	139,650	139,650	139,650	139,650
C	320,170	320,170	320,170	320,170
D	307,350	307,350	307,350	307,350
D'	591,770	671,420	671,420	565,220
D1	647,100	647,100	647,100	539,100
D1'	212,000	232,000	232,000	192,000
E	475,200	475,200	475,200	475,200
F	897,260	897,260	897,260	814,060
W.R.	76,050	76,050	76,050	76,050
A3	176,220	176,220	176,220	176,220
A1	179,550	179,550	179,550	179,550
A2	232,920	232,920	232,920	232,920
A2'	64,260	64,260	64,260	64,260
A2a	189,450	189,450	189,450	189,450
F.S.	719,000	597,500	597,500	597,500
SWID	428,400	356,400	356,400	356,400
TOTAL	\$12,745,135	\$12,239,185	\$11,565,595	\$11,218,295

a/ Costs include lift stations every 250 ft (4 ft-dia. for pipes < 21 in; 6 ft-dia. for pipes > 21 in).

b/ Costs assume a maximum depth of cut of 8 ft. and installed trench safety system.

c/ Costs do not include O&M (\$75/day/each for service), power, engineering, or right-of-way.

Figure VII.29
Georgetown Regional Wastewater Planning Study
Total Cost of Collection Systems
(Same for With and Without Water Conservation)

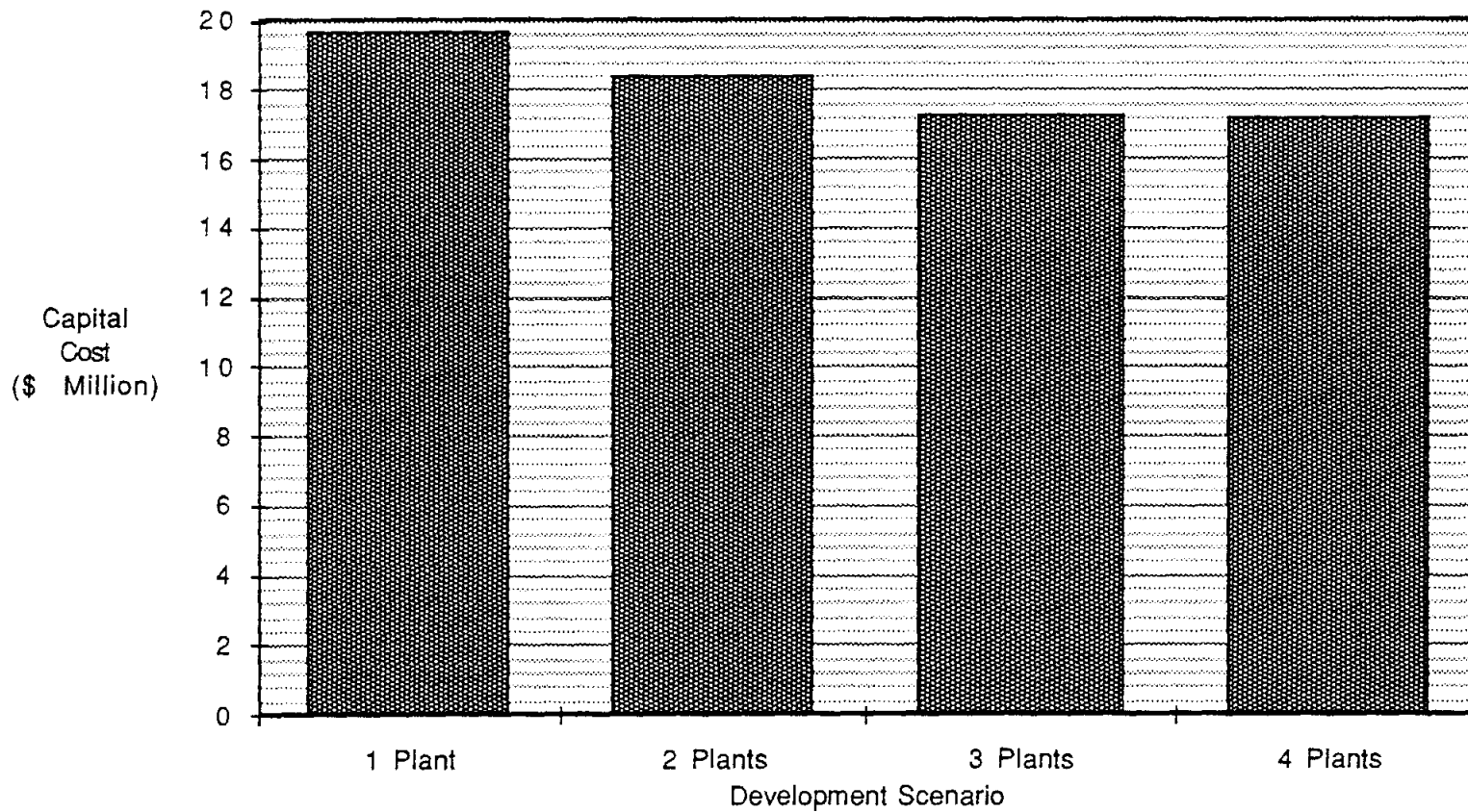

VIII OVERALL EVALUATION AND RECOMMENDATIONS

VIII.A Evaluation of Alternative Scenarios

A variety of locations were evaluated as potential sites for additional wastewater treatment facilities in the Georgetown Regional Planning Study. Initially, fifteen potential sites were considered, and of these four were selected for further consideration. The four sites chosen for analysis were:

- The City of Georgetown wastewater facility located along the San Gabriel River just downstream of the park road bridge;
- Dove Springs Development Corporation located along an unnamed fork of Mankin's Branch Creek in the vicinity of CR 102;
- Mankin's Crossing at the San Gabriel River between State Highway 29 and the Mankin's Branch Creek confluence; and
- Berry Creek near the confluence of the San Gabriel River and Pecan Branch Creek.

Many factors were taken into account in making the final site recommendations. As with any wastewater treatment facility, the impact of discharges into receiving streams had to be considered, and treatment levels necessary to achieve standards specified by the TWC for Segment 1248 had to be determined. In addition, much of the Georgetown Regional Planning Area is located over the recharge zone of the Edwards Aquifer. This provides a further constraint in planning, because the TWC has prohibited additional discharges into streams overlying the recharge zone of the aquifer.

Other factors that were considered during the course of the study included additional environmental constraints, such as biological considerations or archaeological features, that might influence the ultimate choice of site(s). Finally, the costs associated with scenarios that met the requisite criteria were considered, in order to determine the most economical alternative.

This section presents a synopsis of the data as it pertains to the site selection process.

VIII.A.1 Water Quality Constraints

Section V describes the expected water quality downstream of the outfall of a variety of wastewater treatment plants at various treatment levels. Several scenarios were constructed in order to determine the combination of plants that would give a total treatment capacity of 8 MGD while maintaining water quality levels in the receiving stream above the minimum DO level of 5 mg/L. The following conclusions were drawn from the QUAL-TX modeling of Segment 1248:

- The City of Georgetown could discharge up to approximately 4 MGD from the existing facility with a treatment level upgrade to 10/3/4 and installation of an outfall main to discharge effluent beyond the Edwards Aquifer recharge zone. The minimum DO, under summer critical low flow conditions, resulting from this discharge would be 5.2 mg/L. It is not likely that the City of Georgetown's treatment facility could be expanded beyond 4 MGD without requiring a treatment level of 5/2/5.
- With or without upgrading the City of Georgetown facility, the proposed Dove Springs WWTP could discharge 2.4 MGD at a treatment level of 10/3/4 without violating the main stem of the San Gabriel River (Segment 1248) minimum DO level of 5.0 mg/L under critical summer low flow conditions.
- Without upgrading the Georgetown facility to a treatment level of 10/3/4, the combined discharge of the Dove Springs Development Corporation and Mankin's Crossing facilities at 5.5 MGD (a total segment treatment capacity of 8 MGD) would result in violation of the 5.0 mg/L minimum DO criterion. The minimum predicted DO concentration is 4.3 mg/L.
- With the City of Georgetown facility upgraded to a treatment level of 10/3/4, Dove Springs Development Corporation could discharge up to 2.4 MGD and the Mankin's Crossing facility could discharge up to 3.0 MGD, both at a treatment level of 10/3/4, without violating the state criterion.
- Without upgrading the Georgetown facility to a treatment level of 10/3/4 a combined discharge of Dove Springs Development Corporation, Mankin's Crossing and Berry Creek facilities at 5.5 MGD (a total treatment capacity of 8 MGD) would result in violation of the 5.0 mg/L minimum DO criterion. The minimum predicted DO concentration is 4.3 mg/L.
- With the City of Georgetown facility upgraded to a treatment level of 10/3/4, Dove Springs Development Corporation could discharge up to 1 MGD, a Berry Creek facility up to 2 MGD, and the Mankin's Crossing facility could discharge up to 2.5 MGD, all at a treatment level of 10/3/4, without violating the state criterion. The minimum predicted DO concentration is 5.1 mg/L.
- A 7 MGD facility located at Berry Creek or an 8 MGD facility located at Mankin's Crossing would require a treatment level of 5/2/5 to maintain DO levels above 5 mg/L at summer critical low flow conditions.

Immediately downstream, Lake Granger (Segment 1247) is directly affected by the quality of the effluent discharged into Segment 1248. EPA National Eutrophication Survey data for Texas lakes indicate that Lake Granger is most likely phosphorus limited. This suggests that control of point and nonpoint source phosphorus may be important. However, this factor did not affect the choice of future plant locations.

VIII.A.2 Environmental Considerations

The geological, biological and cultural resources of the area were surveyed in order to determine whether there were any features that would be determinative in choosing the location of the treatment plant(s). The most critical factor in this study was determining the eastern edge of the recharge zone of the Edwards Aquifer. The geological study was specifically designed to address this point, as well as to determine the location of wells producing potable water from the aquifer. The survey confirms the original assumption that the three new sites chosen for consideration, Berry Creek, Dove Springs and Mankin's Crossing, are not located on the recharge zone of the Edwards Aquifer.

The biological survey, which included sampling at five sites along Segment 1248, indicated that no biological habitats of particular note would be adversely affected by the construction of a WWTP at any of the proposed locations. Several endangered or threatened bird species have been observed in the area, but the immediate vicinity does not appear to be a preferred habitat for any of them.

A survey of cultural resources revealed that the area is rich in archaeological sites. The only extensive excavations have taken place in association with the construction of reservoirs. However, the available information indicates that sites are likely to be prevalent in drainages, particularly at the confluence of streams. Availability of lithic raw materials and proximity to springs increases the probability of such sites. Thus, potential WWTPs may be located on prehistoric sites. These sites are particularly significant and also difficult to identify if buried in alluvial landforms. A complete archaeological survey of any proposed site is recommended, and may be required by the EPA or the TWDB. None of the proposed sites was eliminated based on this brief survey.

VIII.A.3 Economic Considerations

Following water quality modeling of selected combinations of sites at various treatment levels, five scenarios were selected for economic evaluation. It is assumed that each of these scenarios meets the TWC criteria for maintaining minimum DO concentrations, as specified by the TWC, for Segment 1248 of the San Gabriel River. Thus, further narrowing down of the alternatives is likely to rely heavily on economic considerations.

As described in Section VII, cost estimates have been derived for each scenario, with and without 15 percent water conservation. The analysis estimated the capital costs of each option in 1990 dollars with a 25 year pay-out period at 10 percent interest. Annual costs were then converted to present (1990) values using a 5 percent annual discount rate. The rationale for discounting the costs in this way was to allow for the time value of money and to give greater weight to construction costs that had to be incurred immedi-

ately. In this way, economic value could be assigned to measures, such as water conservation, that result in the deferment of capital investment.

Figure VIII.1 compares the present value of each of the five scenarios analyzed in the previous section. Clearly, the cheapest scenario is the two-stage scenario in which temporary package plants are used to service the majority, but not all, of the service area during an initial ten year period. This scenario has the advantage of deferring the capital cost of a large treatment plant for ten years (15 years with water conservation). In deciding on the second stage of this scenario, the other four scenarios were analyzed for costs.

The most expensive alternative is the one plant scenario. Two factors contribute to the heavy costs associated with this option. First, the existing treatment plant is abandoned, resulting in the immediate construction of an additional 2 MGD of capacity as compared with the other scenarios. The other reason is the fact that water quality modeling shows that the construction of a single, large facility, discharging a total of 8 MGD, would have to have a treatment level of 5/2/5 in order to meet minimum DO concentrations, as specified by the TWC, for Segment 1248 of the San Gabriel River. This higher treatment level results in both higher construction and maintenance costs.

Of the remaining three scenarios, cost increases as a function of the number of plants constructed. The primary reasons for this are the economies of scale associated with the construction of these facilities and the fact that there is always a certain level of excess capacity at any WWTP, especially when it is first constructed. This will increase with the number of facilities. Two other factors are pertinent in evaluating the costs associated with these three alternatives: the feasibility and cost of collection systems and the amount of flexibility in accommodating expanded demand.

The addition of a plant at Dove Springs in no way affects the layout of the collection system. Interceptors downstream of the Dove Springs plant can easily be made to accommodate the flows from this location to the Mankin's Crossing facility. Thus, addition of a fourth plant adds unnecessarily to the cost. Without the Berry Creek plant, an additional interceptor would be necessary in order to transport sewage from the Berry Creek watershed to the Mankin's Crossing facility. However, it is unlikely that the costs associated with this would outway the advantages of eliminating this site and choosing the two plant scenario.

An additional advantage of the two plant scenario as opposed to scenarios in which additional plants are constructed concerns flexibility. Given the fact that very large growth projections have been used to construct these scenarios, it is likely that there is considerable inaccuracy associated with the growth scenario constructed for each drainage area. Thus, scenarios that allow for large service areas will accommodate a

Figure VIII.1
 Georgetown Regional Wastewater Planning Study
 Total Cost of Collection and Treatment With and Without Water Conservation

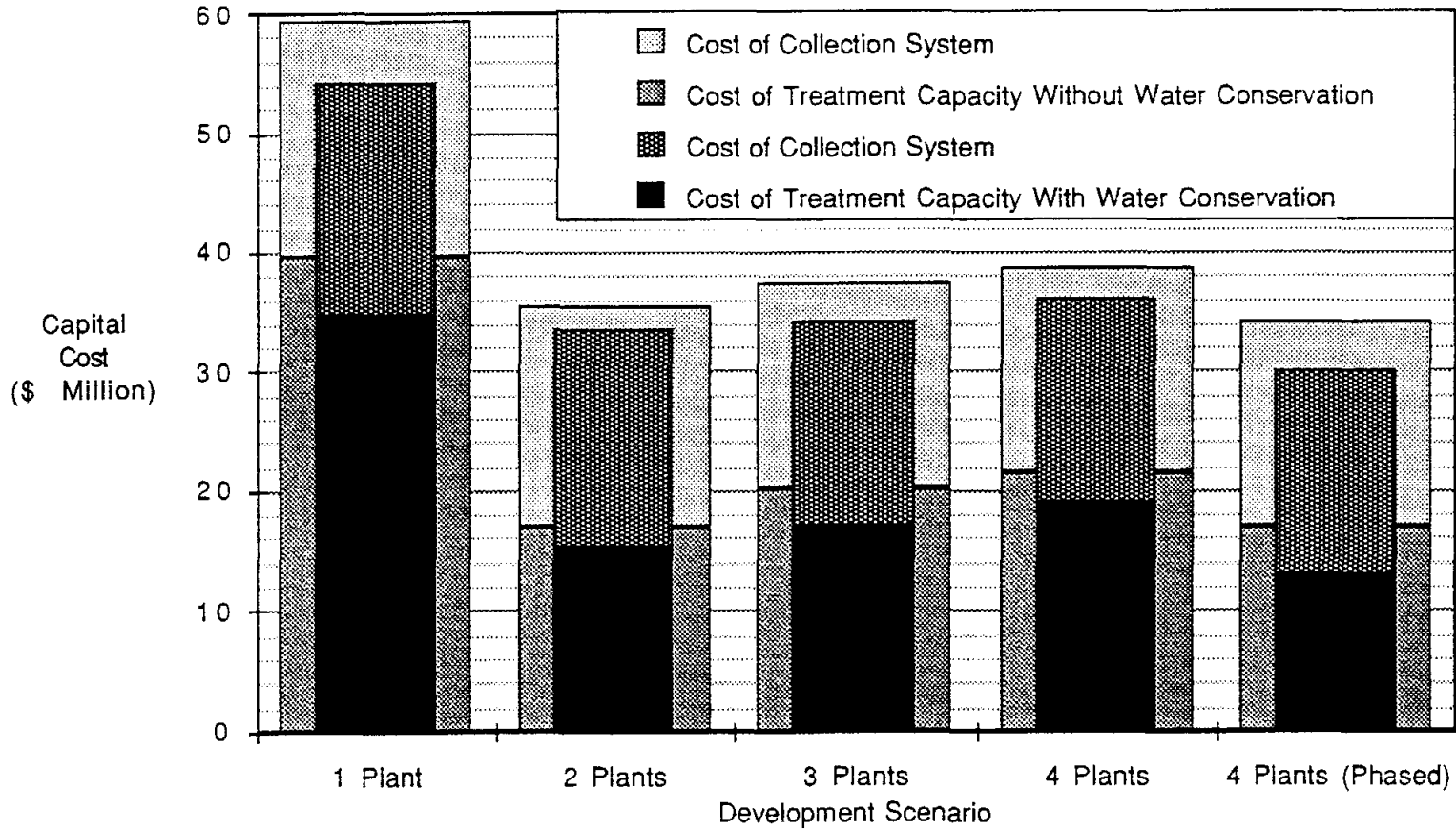

greater degree of flexibility in growth patterns. This will reduce the probability of providing excess capacity at one site, while requiring acceleration of the construction schedule at another.

VIII.B Recommendations

Based on water quality and environmental considerations, five scenarios were evaluated to determine the most cost efficient scenario for providing wastewater treatment in the Georgetown Regional Planning Area. Based on economic considerations the two stage scenario is recommended for implementation. This scenario involves the following construction schedule:

- Immediately converting the existing Georgetown WWTP from a parallel stream process to a single stream, series two-stage process, thereby limiting its capacity to an average daily flow of 1.67 MGD.
- Diverting flows from basins 0 and 3b from the existing plant to a new, 1.2 MGD package plant at Dove Springs. This plant would also serve basins SWID, E and F.
- Constructing a 1.2 MGD temporary package plant at Berry Creek to serve the Berry Creek watershed (basins B, B1 and C) and basin A.
- In 2000 (or when flows to the Dove Springs plant approach plant capacity) replacing this plant with a 2.8 MGD plant at Mankin's Crossing.
- In 2010 (or when the Berry Creek plant approaches full capacity) abandoning this plant and diverting the flows to the Mankin's Crossing plant.
- In 2015 upgrading the existing Georgetown plant to a treatment level of 10/3/4 in order to increase its capacity to 2.5 MGD while complying with the TWC mandate.
- Increasing the capacity of the Mankin's Crossing plant to a total capacity of 5.5 MGD in two phases, in order to extend its life to the end of the planning horizon.
- Implementing a rigorous water conservation plan, in order to defer much of this capital investment for as much as five years.

IX REGIONAL DESIGNATION, INSTITUTIONAL CONSIDERATIONS, AND FINANCIAL PLAN

IX.A Regional Designation

Sections 26.081 through 26.086, Subchapter C, of the Texas Water Code (Vernon's Texas Codes Annotated, Vol. 1, 1988) provide the mechanisms and procedures for creation and designation of regional and area-wide wastewater treatment systems. The goal of regional and area-wide collection and treatment is the prevention of pollution and maintenance and enhancement of water quality. The State's desire to encourage and promote regional wastewater system planning is underscored by the TWDB Planning Grant Program which was created specifically to promote regional planning. The TWDB has identified a number of specific regions and areas throughout the state which are particularly suited to regional planning. The Georgetown area is one of those identified areas.

Creation of designation regional treatment entities and enforced compliance are functions delegated the Texas Water Commission. The following is an abbreviated outline, constructed from Texas Water Code, of the regional designation process.

- § 26.082 Hearing to Define Area of Regional or Area-Wide Systems - Normally, the TWC holds a public hearing to identify a potential designated regional areas when current or projected residential, commercial, industrial, and/or recreational growth will rapidly exceed existing or planned collection and treatment capacities. The TWDB, as part of their ongoing state-wide planning program, formally identified the Georgetown area (in part because of the scenic San Gabriel River and attempts to reduce discharges over the sensitive Edward Aquifer Recharge Zone and in part because of the rapid growth an expansion during the last decade) as desirable and feasible for regional wastewater planning. The TWDB published, in the Texas Register, a formal request for proposals (RFPs) to perform regional wastewater planning activities in and around Georgetown. The City responded to that proposal and subsequently was awarded the regional wastewater planning function and a 50% matching-fund grant. A public hearing was held in Georgetown on describing the proposed wastewater planning activities and project scope.
- § 26.083 Hearing to Designate Systems to Serve the Area Defined - At the hearing to designate the regional area held under § 26.082, or at a separately initiated hearing, the commission may issue an order designating an entity to provide regional or area-wide wastewater collection, treatment, and disposal. Regional designation was not assigned to the City through the awarding of the Planning Grant Funds. The City simply agreed to fund 50% of the project cost, aided by individual contributions, and serve as manager and sponsor the regional planning activities. Sponsorship of TWDB regional planning activities does not commit or empower the City to serve

IX.B Institutional Considerations

Several entities could be considered to manage and maintain the Georgetown Regional Wastewater Plan (GRWWP). These entities include but are not limited to the Brazos River Authority, Williamson County, a special district that would include the approximate planning area, and the City of Georgetown.

The Brazos River Authority ("Authority") possesses the expertise and experience required to properly administer a regional wastewater plan. The "Authority" is an agency that is self sufficient and supports itself from fees and income from its projects. The "Authority" is not intimately involved in development in the Georgetown area and the Georgetown area is only a small part of the overall Brazos River Basin with which the it is concerned. The "Authority" is probably not the most effective agency to operate and maintain the Georgetown Regional Wastewater Plan.

Williamson County is also capable of administering the GRWWP. This is not, however, a normal county function. Williamson County would be directly involved in only a few of the land development projects that could impact the GRWWP. The County is not usually involved in land use planning or zoning and would probably not be an efficient administrator of the GRWWP.

A special district charged specifically with administering the GRWWP could be proposed for creation by the Texas Legislature. Such a district could be given tax raising and fund raising authority to develop income to support a staff to administer the GRWWP. The district would probably require a confirmation election of all the citizens within the district boundaries. However, the electorate and most politicians are normally reluctant to create more bureaucracy and more taxing authorities. Without an overriding, pressing and urgent need, such districts are normally not confirmed. Therefore, a special district is probably not the most expedient way to administer and update the GRWWP.

The City of Georgetown has sufficient staff to administer, update and maintain the GRWWP. The City of Georgetown has adequate funding from wastewater revenues to fund maintenance. It is intimately involved in land development, land use planning, zoning changes and infrastructure improvements. The City is the logical choice for maintaining the GRWWP and becoming the designated regional planning authority by the Texas Water Commission.

The City of Georgetown would be prudent to establish procedures and guidelines for maintaining and operating regional facilities that might involve districts and cities other than Georgetown. Procedures similar to those used by "Authority" for their regional wastewater system would appear to be appropriate. Funding for capital improvements and for the "Authority" staff and overhead is derived from project financing and from project operation and maintenance revenues.

IX.C Financial Plan

The selected alternative for the Georgetown Regional Wastewater System is a two plant system with a plant at Mankin's Crossing and the existing plant in Georgetown. A part of the development of this scenario, due to the current demand and the availability of two large package treatment plants, involves locating these two interim plants at Dove Springs and Berry Creek. Construction of the plant at Mankin's Crossing could thereby be delayed for at least ten years. For the purposes of this report, the cost of these interim plants is used to develop the financial plan.

The acquisition and planning of the implementation of these interim plants is currently being accomplished by the City of Georgetown. Exact cost estimates are not available at this time. For purposes of this report, it is assumed that \$1,000,000.00 would cover the cost of the Dove Springs facility, including the acquisition of the treatment plant, the refurbishing of the treatment plant and erection, along with lift stations, force mains and outfall mains. The proposed layout should be within reasonable conformance with the two plant scenario. A similar, \$1,000,000.00 cost estimate is also used for the interim plant at Berry Creek. This will include acquisition of the plant, acquisition of the site, permitting and installation of the plant, along with the required headworks and outfall line, again in reasonable conformance with the two plant plan.

The construction of additional plants in the Georgetown regional system will certainly increase the operation and maintenance costs for wastewater treatment. Some common use of supervisors, labor, laboratory personnel and equipment should be considered; however additional labor and operator cost is unavoidable. In addition, major costs associated with the operation of the type of plant under consideration are power or energy costs. Operation and maintenance costs are typically \$.50 per thousand gallons of wastewater treated.

The Dove Springs treatment plant is expected to be significantly loaded shortly after commencement of initial operations, as a result of diversions from the currently hydraulically overloaded Georgetown WWTP. The approximate estimated operation and maintenance cost for the Dove Springs facility is \$120,000.00 per year.

The Berry Creek interim plant is most likely to be built in response to increased wastewater service. This could be new subdivisions, relief of existing sewage treatment plants with no discharge permits, or the extension of wastewater service to the large areas of septic tank service in the Georgetown area within the Edwards recharge zone. Due to the nature of this type of service, the Berry Creek plant can be expected to be significantly underloaded during the initial years of operation. The current approximate operation

and maintenance costs during the early years of the Berry Creek plant is assumed to be \$70,000.00 per year.

The City of Georgetown wastewater system in 1988 averaged approximately 4449 customers during the year. Of these, roughly 4000 were residential customers, and approximately 449 were non-residential customers. These customers generated approximately 8000 to 10,000 gallons per month of wastewater. These figures reflect a per capita contribution of approximately 105 gallons per capita daily. The current City of Georgetown wastewater rates are listed in the Table IX.1.

**Table IX.1
Current Wastewater Rates**

Residential	Non Residential
\$5.00/minimum for first 3000 gal.	\$10/minimum for first 3000 gal.
\$1.50/1000 above 3000 gal.	\$1.25/1000 above 3000 gal.

The City of Georgetown has several alternatives available for the financing of the interim facilities. It can finance wastewater facilities with publicly sold tax or revenue bonds or with bonds sold to the Texas Water Development Board under the Water Quality Fund or under the State Revolving Loan Fund.

The City of Georgetown was "A" rated after its last bond issue in 1987. If the "A" rating can be maintained, the City should be able to sell tax bonds in the amount of approximately one million dollars for a rate of approximately 7.5 percent. Tax bonds require an election of the taxpayers and are often not used for revenue producing activities such as wastewater facilities, but are more commonly reserved for non revenue producing facilities such as police facilities, park facilities, fire facilities and other such facilities including street and drainage improvements. The City of Georgetown would probably be well advised not to use tax bonds for financing regional wastewater improvements.

General revenue bonds sold on the open market are a possible source of funding for the regional wastewater system. With the previously mentioned "A" rating, the City of Georgetown could expect to sell revenue bonds on the open market for approximately 8 to 8 1/2 percent. Revenue bonds do not require an election but there are some expenses involved in the marketing of these bonds. Also, the interest rate is subject to market fluctuations and is not known until the bonds are sold.

The State of Texas, through the Texas Water Development Board, has made available water quality bonds to public entities in the State of Texas. These are state bonds which are sold in large amounts and then re-loaned to municipalities such as Georgetown. The current interest rate on these bonds is approximately 8 percent. The advantage of these bonds over the publicly sold revenue bonds is that the interest

rate is known in advance, no ratings or trips to New York are required to market the bonds, and the bonds can be marketed in a relatively short amount of time. The City of Georgetown should seriously consider the Texas Water Development Board's funds as a source of financing for this project.

The state revolving loan fund is a state backed and federal grant supported fund source for wastewater projects for public entities in the State of Texas. The current rate on these bonds is approximately 4 percent. To utilize these funds a city must go through the procedures used for some time by the Environmental Protection Agency and now administered by the Texas Water Development Board. Specifically, the City of Georgetown would need an updated infiltration-inflow analysis, an updated facility plan, and must design the improvements in accordance with the then current regulations. These funds are not available normally to finance step 1 (Infiltration-Inflow Analysis and Facility Plan), or step 2 (Engineering), but become available after the satisfactory completion of these steps and prior to step 3 (Construction). This report supplies much of the information necessary to apply for state revolving loan fund monies.

Soft costs associated with municipal wastewater construction can normally be reduced by not utilizing the State Revolving Loan Fund. These costs include infiltration-inflow analysis, facility planning, and other administrative costs. In some cases hard costs (construction costs) have been reduced by not utilizing State Revolving Loan Fund by reducing the level of redundancy and duplication of facilities in treatment plant construction. If time is a critical element, a more direct method of funding than the State Revolving Loan Fund is recommended.

For purposes of this study, revenue requirements will be estimated using the Texas Water Development Board Funds in the 8 percent range and in the 4 percent range (Table IX.2). Although two interim plants are proposed for 1990, the need for the Dove Springs plant is more pressing and urgent and the need for the Berry Creek plant is less urgent. For these reasons, the financial requirements for the two facilities will be estimated separately, since these plants may well be financed and constructed separately.

The rates shown in Table IX.3 should cover the cost of the amortized capital indebtedness and operation and maintenance costs associated with the proposed facility improvements. The Dove Springs treatment facility with 4 percent and 8 percent financing is shown. A combination of Dove Springs at 8 percent and Berry Creek plant at 4 percent financing is also shown. No increase in customer count is included in these projections, so the last projection with Berry Creek is extremely conservative.

**Table IX.2
Cost Requirements Analysis**

Facility and Expense	4% Funds	8% Funds
Dove Springs:		
Operation & Maintenance Cost per year	\$120,000	\$120,000
Approximate Amortization Cost on \$1,000,000 Budget per year	\$73,580	\$117,460
Approximate Total Annual Requirement	\$193,580	\$237,460
Average Increase in Revenue Required per Customer per Month (4449 Customers)	\$ 3.63	\$4.45
Berry Creek:		
Operation & Maintenance Cost per year	\$ 70,000	\$ 70,000
Approximate Amortization Cost on \$1,000,000 Budget per year	\$ 73,580	\$117,460
Approximate Total Annual Requirement	\$143,580	\$187,460
Average Increase in Revenue Required per Customers per Month (4449 Customers)	\$2.69	\$3.51

**Table IX.3
Rate Requirement Analysis**

Classification	Minimum	Over Minimum	8,000 Gal. Bill	Net Change
Current Rates				
Residential	\$5.00/3000 gal	\$0.25/1000 gal	\$11.25	-
Non Residential	\$10.00/3000 gal	\$1.50/1000 gal	\$17.50	-
Possible Rate with Dove Springs (4%)				
Residential	\$7.50/3000 gal	\$1.50/1000 gal	\$15.00	+\$3.75
Non Residential	\$14.00/3000 gal	\$1.50/1000 gal	\$21.50	+\$4.00
Possible Rate with Dove Springs (8%)				
Residential	\$8.25/3000 gal	\$1.50/1000 gal	\$15.75	+\$4.50
Non Residential	\$14.50/3000 gal	\$1.50/1000 gal	\$22.00	+\$4.50
Possible Rate with Dove Springs (8%) and Berry Creek (4%)				
Residential	\$10.00/3000 gal	\$1.75/1000 gal	\$18.75	+\$7.50
Non Residential	\$16.50/3000 gal	\$1.75/1000 gal	\$25.25	+\$7.75

X WATER CONSERVATION AND DROUGHT CONTINGENCY PLANNING

X.A Introduction

X.A.1 Planning Area and Project

Because of the projected growth in the Georgetown area, the Cities of Georgetown and Weir have agreed to participate in a feasibility study for the development of regional wastewater facilities. This study, financed by the Texas Water Development Board, was initiated as a result of House Bill (HB) 2 and House Joint Resolution (HJR) 6, passed by the 65th Texas Legislature in 1985, in order to encourage cost-effective regional water and wastewater facility development.

The service area established for the current study is generally described as the Georgetown ETJ and the Town of Weir. It includes the certified service area of the Williamson County MUDs #5 and #6, approximately 1,500 acres of privately owned land and portions of major watersheds that include the San Gabriel River, Berry Creek, Pecan Branch, Smith Branch and Mankin's Branch. The area projected for future urban development by the Georgetown Century Plan is, for the most part, within the study service area.

The overall objective of the study is to determine the adequacy of the existing wastewater treatment facility given population growth projections and the fact that flows being received by the existing treatment plant approach and occasionally exceed the rated plant capacity. Given that additional treatment capacity will be needed, cost estimates will be determined for various alternative development scenarios. These include the phasing in of different-sized treatment plants at a variety of locations. In this section we describe water conservation measures that could have an impact on the projected wastewater treatment demands and therefore the phasing of projects.

X.A.2 Utility Evaluation Data

The study service area covers approximately 61 square miles (39,000 acres) and is generally circular in shape. The current service area population is estimated at between 16,000 and 18,000; the Georgetown water system currently serves some 6,000 customers. The remainder of service in the area is provided by one of two water supply corporations or private on-site wells. Georgetown's average daily water pumpage was 3.8 million gallons per day (MGD) or 222 gallons per capita per day (gcd) in 1986. The peak pumpage for this period was 8.79 MGD or 517 gcd. Of the total water pumped during 1986 some 46 percent was not metered according to the July 1987 Century Plan Utility Study. This study projects average demand for the year 2010 at 13.93 MGD (216 gcd) and a peak demand of 31.5 MGD (489 gcd).

The City is currently supplied via a series of groundwater wells with an average daily capacity of about 5 MGD and a peak capacity of 8.5 MGD under non-drought conditions. Additionally, the recently

constructed surface water treatment plant at Lake Georgetown can provide 6 MGD average and 18 MGD peak supply. Treatment capacity is limited to 6 MGD at the surface water plant and 6 MGD at the groundwater facility located near San Gabriel Park.

The City of Georgetown wastewater system is the major organized system treatment facility in the service area. A small facility with a zero discharge permit serves Williamson County MUDs No. 5 and 6. The balance of the area is served by on-site disposal systems (septic systems). The Georgetown wastewater treatment plant is located along the San Gabriel River opposite San Gabriel Park, north and east of downtown. This facility has an average daily rated capacity of 2.5 MGD. The permitted discharge is 2.5 MGD averaged over a month and 3.5 MGD maximum on any given day. The actual average discharge for 1986 was 1.897 MGD and for 1987 was 1.718 MGD. Projected discharge for 1990 is 1.808 MGD.

X.A.3 Need for and Goals of Program

The Texas Water Development Board has promulgated Financial Assistance Rules which require water conservation planning for any entity receiving financial assistance from the Board. The origin of these requirements is HB 2 and HJR 6. On November 5th, 1985 Texas voters approved an amendment to the Texas Constitution that provided for the implementation of HB 2. Because the City of Georgetown has already adopted a drought contingency plan, this document provides specific guidelines for developing a water conservation program that will meet the regulatory requirements of the Texas Water Development Board for the Georgetown Regional Planning Area.

Since the early 1960s per capita water use in the state has increased approximately four gallons per capita per decade. More important, per capita water use during droughts is typically about one third greater than during periods of average precipitation. Thus, the goals of the program are to reduce overall water usage through water conservation practices and to provide for a reduction in water usage during times of shortage.

Water use in the residential and commercial sectors involves day-to-day activities of all citizens of the state, and includes drinking, bathing, cooking, toilet flushing, fire protection, lawn watering, swimming pools, laundry, dishwashing, car washing and sanitation. The objective of a conservation program is to reduce the quantity of water required for each of these activities, where practical, through implementation of efficient water use practices. The drought contingency program provides procedures for both voluntary and mandatory actions placed in effect to temporarily reduce usage demand during a water shortage crisis. Drought contingency procedures include water conservation and prohibition of certain uses. Both are tools that city officials will have available to them in order to effectively operate in all situations.

The water conservation plan outlined below will have the overall objective of reducing water consumption in the Georgetown area. It will have the added advantage of reducing the amount of wastewater needing treatment. Because the focus of this report is regional planning for wastewater treatment needs, we will focus on measures that specifically reduce the amount of wastewater produced. Such measures will have the effect of extending the time until additional wastewater treatment capacity must be provided.

Various cities throughout the country have adopted water conservation techniques and technologies depending upon the severity of their water supply situation. In particular, California has taken significant steps to reduce water consumption, and here in Texas, Austin has an aggressive water conservation program. Drawing on the experiences of some of these cities, we can make some assumptions about the feasibility, cost and effectiveness of specific measures. For the purpose of reducing the quantities of wastewater produced, two of the measures outlined below deserve particular attention: adopting vigorous plumbing codes for new construction and retrofitting.

According to the TWDB figures, between 1990 and 2030, a fourfold increase in population is to be expected in the Georgetown Regional Planning Area. A similar increase in wastewater flows is also projected (with a minimal, 5 percent reduction in per capita production by 2030). With such high rates of growth, it is evident that the greatest savings in water usage can be realized by adopting stringent plumbing codes for new construction. Nationwide it is being realized that the marginal cost of supplying wastewater treatment facilities is so high that new plumbing codes that reduce water usage by 25-30 percent are the most economical solution. If such a code were adopted by Georgetown, wastewater production in all new construction would be reduced from 110 gcd to 80 gcd.

Existing facilities can also be retrofitted in order to reduce water consumption. Although this may involve some capital outlay, all of the measures are cost-effective, and various schemes have been devised to recover the costs. For instance, a plan for San Antonio assumes that a 2 percent increase in water and wastewater rates for 5 years would raise enough money to cover a \$100 rebate for each customer retrofitting a toilet to flush on 1.5 gallons (resulting in an overall savings on the customer's water and wastewater bill). An aggressive retrofit program can result in water savings of 15-25 percent per residence. With market penetration typically running at 20-50 percent, this would result in an overall water consumption savings of around 5 percent. In its water conservation program, the City of Austin estimates a 6.7 percent savings within 5 years. This program consists of substituting low-flow shower heads, installing toilet dams and checking for leaks. The benefit/cost ratio is estimated at more than ten, with an average savings to the customer of \$52/year from reductions in water, wastewater and electricity.

In Figure X-1, TWDB projections for wastewater flows in the Georgetown area to the year 2030 are shown. Also shown are the flows that would result from the adoption of the two measures outlined above. Overall savings in wastewater flows by 2020 are approximately 18 percent. The assumptions made are:

- adoption of a code that would reduce water consumption in all new construction from 110 gcd to 80 gcd;
- this code would be phased in during the 1990s (for this period 90 gcd was used in the estimate);
- existing uses could be reduced by 5 percent through retrofit and other conservation measures.

These savings in water demand can be related directly to savings in wastewater collection and treatment costs. By reducing average daily demand and peak 2 hour flows to the wastewater plants by as much as 15 percent, collection systems, lines and required wastewater treatment capacity will be reduced commensurably by 15 percent. Operation and maintenance costs to the wastewater systems will also be reduced because of lower chemical requirements, reduced pumping requirements and appropriate lift station sizing. Design of water treatment and distribution systems, however, are influence more by fire protection requirements than average daily per capita water usage. Fire protection demands are a function of population quantities and densities and are are not significantly influenced by water conservation programs. Average daily treatment capacities, water treatment plant chemical costs, operation and maintenance costs and pumping costs will be reduced significantly through the imposition of water conservation measures.

The drought contingency program includes those measures that can cause the city to significantly reduce water use on a temporary basis. These measures involve voluntary reductions, restrictions and/or elimination of certain types of water use and water rationing. Because the onset of an emergency condition is often rapid, it is important that the city be prepared in advance. Further, the citizen or customer must know that certain measures not used in the water conservation program may be necessary if a drought or other emergency condition occurs. With the adoption of Ordinance 84-42, the City of Georgetown has provided for the orderly implementation of a drought management scheme that gives the mayor the authority to declare an emergency situation in response to specific triggering criteria.

X.B Long-term Water Conservation

X.B.1 Plan Elements

Nine principal water conservation methods are delineated as part of the proposed water conservation plan.

Figure X.1
Georgetown Regional Wastewater Planning Study
Wastewater Flow Projections With and Without Water Conservation

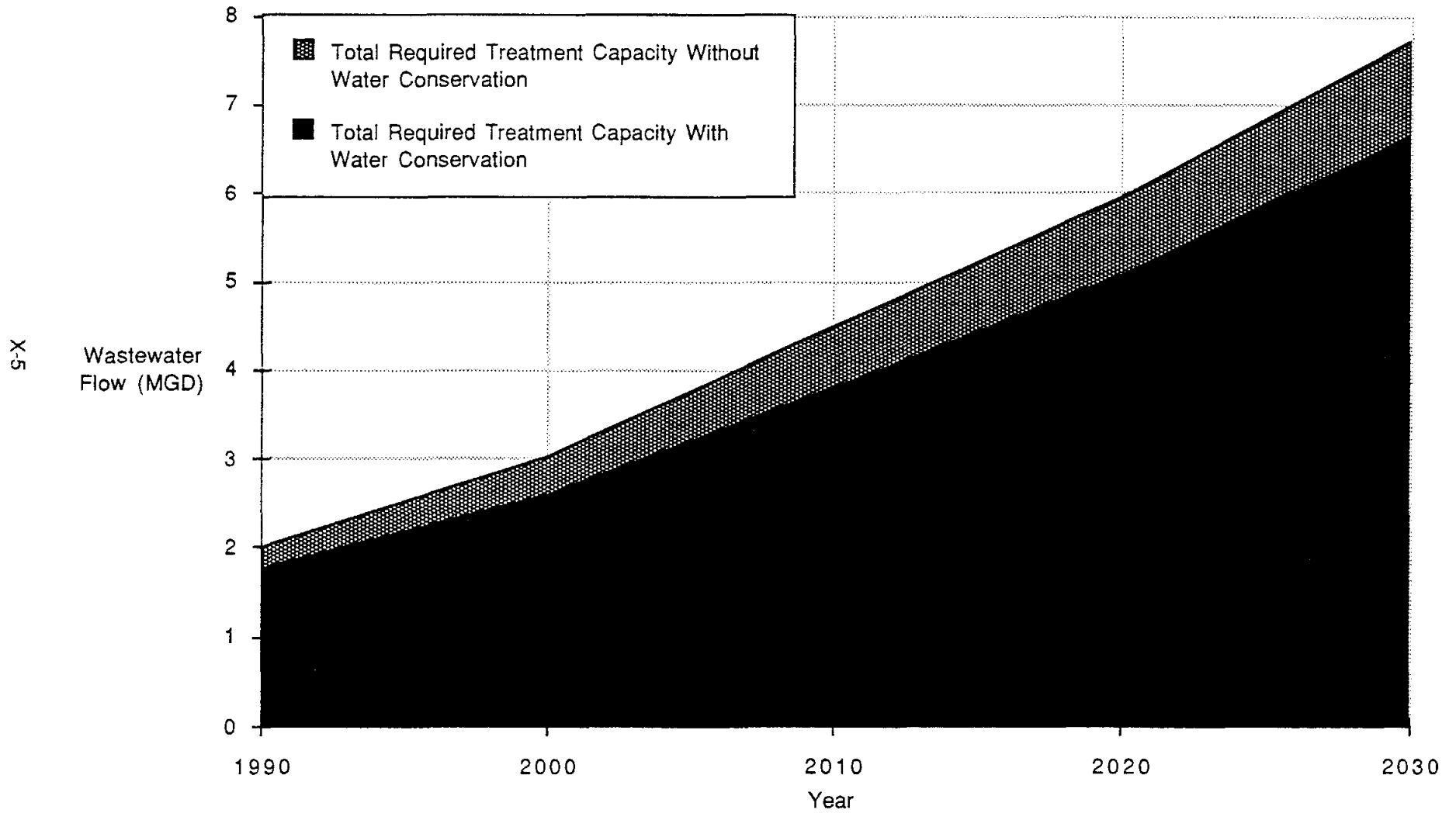

X.B.1.a Education and Information

The City of Georgetown will promote water conservation by informing water users about ways to save water inside of homes and other buildings, in landscaping and lawn maintenance, and in recreational uses. Information will be distributed to water users as follows:

Initial Year:

- The initial year shall include the distribution of educational materials outlined in the Maintenance Program section.
- Distribution of a fact sheet explaining the newly-adopted Water Conservation Program and the elements of the Drought Contingency Plan. The initial fact sheet shall be included with the first distribution of educational material.
- In addition to activities scheduled in the Maintenance Program, an outline of the program and its benefits shall be distributed either through the mail or as a door-to-door hand-out.

Maintenance Program:

- Distribution of educational materials will be made semi-annually, timed to correspond with peak summer demand periods. The City currently distributes such material and will incorporate material available from the American Water Works Association (AWWA), Texas Water Development Board (TWDB) and other similar associations in order to expand the scope of this project. A wide range of materials may be obtained from:

Texas Water Development Board
P.O. Box 13231, Capitol Station
Austin, Texas 78711-3231

- Regular articles will be published in the Williamson County Sun, a widely circulated area newspaper. These publications will correspond to distribution of the mailouts, or more often if conditions warrant.
- New customers will be provided with a similar package of information as that developed for the initial year, namely, educational material, a fact sheet explaining both the Water Conservation Program and the elements of the Drought Contingency Plan, and a copy of "Water Saving Methods that can be Practiced by the Individual Water User."

X.B.1.b Plumbing Codes

The City of Georgetown has adopted Appendix J of the 1985 version of the Standard Plumbing Code which requires water saving plumbing devices on all new construction. The Codes has been in effect for several years. It will be amended to include insulation of all hot water heater pipes and appropriate filtration equipment for new swimming pools.

During the 1990s a more stringent plumbing code will be adopted for all new construction and remodelled structures. The most significant components under consideration are:

- showers used for other than safety reasons shall be equipped with approved flow control devices to limit total flow to a maximum of 3 gallons per minute (gpm);
- toilets shall use a maximum of 1.6 gallons per flush;
- urinals shall use a maximum of 1.5 gallons per flush.

XI.B.1.c Retrofit Program

The City of Georgetown will make available, through its education and information programs, pertinent information for the purchase and installation of plumbing fixtures, lawn watering equipment and appliances. The advertising program will inform existing users of the advantages of installing water saving devices. The City will contact local plumbing and hardware stores and encourage them to stock water conserving fixtures, including retrofit devices.

In addition, the City will embark upon an aggressive retrofit program. Several alternatives are summarized in Table X.1. Market penetration is based on the experience of other cities offering such programs. Savings are calculated on the basis of 2.72 persons per household for a total of 5,472 residences in the Georgetown area.

The least cost alternative is to deliver two packages/house containing two flow restrictors, a plastic restrictor for a shower head, a toilet bag and two dye tablets. Based on past experience, the toilet bags are the most acceptable to customers and could be expected to realize savings of 4.8 gpd in participating households. A more acceptable and more permanent option is to provide customers with low-flow shower heads and toilet dams. Because of the greater costs associated with providing these items, vouchers would be included in the water bill to be exchanged at convenient locations for each neighborhood. It is assumed that most of the equipment claimed through this mechanism would be installed. Another more full-proof system, used extensively in the City of Austin, involves the installation of low-flow shower heads and toilet dams at no charge to the customer. In Austin market penetration has exceeded 50 percent and

Table X.1
 Expected Savings to the City of Georgetown
 Through Implementation of a Water Use
 Retrofit Program

Action	Cost/house ^{a/}	Savings/hse ^{b/}	Penetration ^{c/}	Total savings	Total cost ^{d/}	Cost/gpd ^{e/}
Distribution of water saving kits ^{f/}	\$1.00	13.1 gpd	50 percent	35,721 gpd	\$2,736	\$0.076
Vouchers for shower heads and toilet dams ^{g/}	\$8.00	27.7 gpd	20 percent	30,315 gpd	\$8,755	\$0.289
Installation of shower heads and toilet dams ^{h/}	\$20.00	27.7 gpd	50 percent	75,787 gpd	\$54,720	\$0.722
Refunds for replacing toilets ^{i/}	\$200.00	32.6 gpd	10 percent	17,832 gpd	\$109,440	\$6.137

- ^{a/} Assumes two bathrooms per single-family residence.
- ^{b/} Based on 110 gpd.
- ^{c/} Percentage of residences participating fully in the program.
- ^{d/} Total program implementation cost.
- ^{e/} Cost per gpd saved.
- ^{f/} Assumes free distribution to all service area residences @ two kits per residence.
- ^{g/} Assumes participant retrieval of kits @ two kits per residence.
- ^{h/} Assumes installation by City personnel or private contractors.
- ^{i/} Assumes \$100 per toilet.

in participating household has resulted in water savings of around 15 percent. A fourth option is to provide rebates of \$100 to customers who replace their toilets with those that flush on 1.5 gallons.

X.B.1.d Water Rate Structure

The City of Georgetown has changed its water rate structure from a declining block rate to a more progressive rate structure. Three new rate tiers have been adopted for residential customers, with the lowest priced tier based on average residential consumption during winter months. The higher rate blocks would be given higher base rates during summer months. A different rate structure is used for employment customers. Because this new rate structure is still not conducive to conservation, an additional modification is under consideration. This would be designed with two objectives in mind: to encourage conservation by penalizing water use above base flows required by each use; and raising revenues in order to pay for the retrofit program and/or the capital cost of providing additional treatment capability.

X.B.1.e Universal Metering

All water users, including utility, City offices and public facilities are currently metered. Also master meters are installed and periodically calibrated at all existing water sources. All new construction, including multi-family dwellings, are separately metered. The program of universal metering will continue, and is made part of the Water Conservation Plan.

The City of Georgetown, through its computer billing system, currently monitors water consumption and inspects meters that vary from previously established norms. In addition, the City will establish the following meter maintenance and replacement programs:

<u>Meter Type</u>	<u>Test and Replacement Period</u>
Master meter	Annually
Larger than 1 inch	Annually
1 inch and less	Every 5 years

Through a successful meter maintenance program, coupled with computerized billing and leak detection programs, the City will be able to maintain water delivery rates, from production to consumer, in the 85 percentile range.

X.B.1.f Water Conservation Landscaping

In order to reduce the demands placed on the water system by landscape watering, the City, through its information and education program, will encourage customers and local landscaping companies to utilize water saving practices during installation of landscaping for residential and commercial institutions. The following methods will be promoted by the education and information program:

X.B.1.i Implementation/Enforcement

The staff of the Public Utility Division of the City of Georgetown will administer the Water Conservation Program. They will oversee the execution and implementation of all elements of the program and supervise the keeping of adequate records for program verification.

The plan will be enforced through the adoption of the Water Conservation Plan by ordinance of the City Council of the City of Georgetown in the following manner:

- Water service taps will not be provided to customers unless they have met the plan requirements.
- The proposed block rate structure should encourage retrofitting of old plumbing fixtures that use large quantities of water.
- The building inspector will not certify new construction that fails to meet plan requirements.

The City will adopt the final approved plan and commit to maintain the program for the duration of the City's financial obligation to the State of Texas.

X.B.2 Annual Reporting

In addition to the above outlined responsibilities, the City staff will submit an annual report to the Texas Water Development Board on the Water Conservation Plan. The report will include the following:

- Information that has been issued to the public.
- Public response to the plan.
- The effectiveness of the water conservation plan in reducing water consumption, as demonstrated by production and sales records.
- Implementation progress and status of the plan.

X.B.3 Contracts with Other Political Subdivisions

The City will, as part of a contract for sale of water to any other political subdivision, require that entity to adopt applicable provisions of the City's water conservation and drought contingency plan or already have a TWDB-approved plan in effect. These provisions will be through contractual agreement prior to the sale of water to the political subdivision.

- Encourage subdivisions to require drought-resistant grasses and the use of low water using plants.
- Initiate a program to encourage the adoption of xeroscaping.
- Encourage landscape architects to use low water using plants and grasses and efficient irrigation systems.
- Encourage licensed irrigation contractors to use drip irrigation systems, when possible, and to design all irrigation systems with conservation features such as sprinklers that emit large drops rather than a fine mist and a sprinkler layout that accommodates prevailing wind patterns.
- Encourage commercial establishments to use drip irrigation for landscape watering, when practical, and to install only ornamental fountains that use minimal quantities of water, including recycling features.
- Encourage local nurseries to offer adapted, low water using plants and grasses and efficient watering devices.

X.B.1.g Leak Detection and Repair

The City will utilize modern leak detection techniques, including listening devices, in locating and reducing leaks. Through its computerized billing program the City can readily identify excessive usage and takes steps to determine whether it is a result of leakage. Once located, all leaks are immediately repaired. A continuous leak detection and repair program is vital to the City's profitability. The City is confident that the program more than pays for itself. A monthly accounting of water delivery efficiencies is made by the City.

X.B.1.h Recycle and Reuse

The City of Georgetown owns and operates a wastewater treatment facility northeast of the City. The City has contracted with the adjacent golf course for use of treated effluent for irrigation. Additional reuse, possibly by the cemetery or nearby agricultural fields, may be explored, if current Texas Health Department requirements can be met.

X.B.1.i Implementation/Enforcement

The staff of the Public Utility Division of the City of Georgetown will administer the Water Conservation Program. They will oversee the execution and implementation of all elements of the program and supervise the keeping of adequate records for program verification.

The plan will be enforced through the adoption of the Water Conservation Plan by ordinance of the City Council of the City of Georgetown in the following manner:

- Water service taps will not be provided to customers unless they have met the plan requirements.
- The proposed block rate structure should encourage retrofitting of old plumbing fixtures that use large quantities of water.
- The building inspector will not certify new construction that fails to meet plan requirements.

The City will adopt the final approved plan and commit to maintain the program for the duration of the City's financial obligation to the State of Texas.

X.B.2 Annual Reporting

In addition to the above outlined responsibilities, the City staff will submit an annual report to the Texas Water Development Board on the Water Conservation Plan. The report will include the following:

- Information that has been issued to the public.
- Public response to the plan.
- The effectiveness of the water conservation plan in reducing water consumption, as demonstrated by production and sales records.
- Implementation progress and status of the plan.

X.B.3 Contracts with Other Political Subdivisions

The City will, as part of a contract for sale of water to any other political subdivision, require that entity to adopt applicable provisions of the City's water conservation and drought contingency plan or already have a TWDB-approved plan in effect. These provisions will be through contractual agreement prior to the sale of water to the political subdivision.